

# 56F8014

Data Sheet

*Preliminary Technical Data*

**56F8000**

**16-bit Digital Signal Controllers**

MC56F8014

Rev. 3

9/2005

## Document Revision History

Version History	Description of Change
Rev 0	Initial release
Rev 1	Updates to <a href="#">Part 10, Specifications</a> , <a href="#">Table 10-1</a> , added maximum clamp current , per pin <a href="#">Table 10-11</a> , clarified variation over temperature table and graph <a href="#">Table 10-15</a> , added LIN slave timing
Rev 2	Added alternate pins to <a href="#">Figure 11-1</a> and <a href="#">Table 11-1</a> .
Rev 3	Corrected bit selects in Timer Channel 3 Input (TC3_INP) bit 9 , <a href="#">Section 6.3.1.7</a> , clarified <a href="#">Section 1.4.1</a> , and simplified notes in <a href="#">Table 10-9</a> ,

Please see <http://www.freescale.com> for the most current Data Sheet revision.

# 56F8014 General Description

- Up to 32 MIPS at 32MHz core frequency
- DSP and MCU functionality in a unified, C-efficient architecture
- 16KB Program Flash
- 4KB Unified Data/Program RAM
- One 5-channel PWM module
- Two 4-channel 12-bit ADCs
- One Serial Communication Interface (SCI) with LIN slave functionality
- One Serial Peripheral Interface (SPI)
- One 16-bit Quad Timer
- One Inter-Integrated Circuit (I<sup>2</sup>C) Port
- Computer Operating Properly (COP)/Watchdog
- On-Chip Relaxation Oscillator
- Integrated Power-On Reset and Low-Voltage Interrupt Module
- JTAG/Enhanced On-Chip Emulation (OnCE™) for unobtrusive, real-time debugging
- Up to 26 GPIO lines
- 32-pin LQFP Package

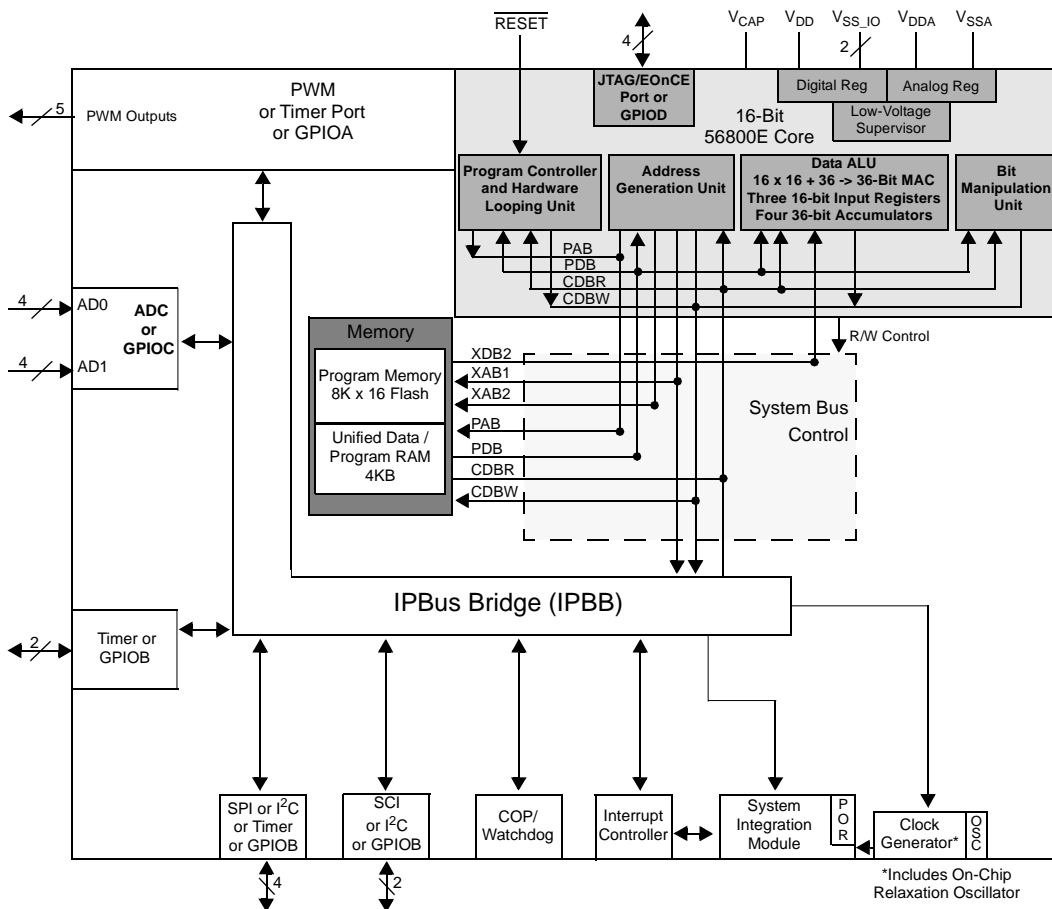

**56F8014 Block Diagram**

# 56F8014 Data Sheet Table of Contents

<b>Part 1: Overview</b> .....	<b>5</b>	<b>Part 7: Security Features</b> .....	<b>82</b>
1.1. 56F8014 Features .....	5	7.1. Operation with Security Enabled .....	82
1.2. 56F8014 Description .....	6	7.2. Flash Access Lock and Unlock Mechanisms	82
1.3. Award-Winning Development Environment ..	7		
1.4. Architecture Block Diagram .....	7		
1.5. Product Documentation .....	11		
1.6. Data Sheet Conventions .....	11		
<b>Part 2: Signal/Connection Descriptions</b> ...	<b>12</b>	<b>Part 8: General Purpose Input/Output (GPIO)</b> .....	<b>84</b>
2.1. Introduction .....	12	8.1. Introduction .....	84
2.2. 56F8014 Signal Pins .....	15	8.2. Configuration .....	84
		8.3. Reset Values .....	86
<b>Part 3: OCCS</b> .....	<b>24</b>	<b>Part 9: Joint Test Action Group (JTAG)</b> ...	<b>91</b>
3.1. Overview .....	24	9.1. 56F8014 Information .....	91
3.2. Features .....	24		
3.3. Operating Modes .....	24	<b>Part 10: Specifications</b> .....	<b>91</b>
3.4. Block Diagram .....	26	10.1. General Characteristics .....	91
3.5. Pin Descriptions .....	27	10.2. DC Electrical Characteristics .....	95
		10.3. AC Electrical Characteristics .....	98
<b>Part 4: Memory Map</b> .....	<b>27</b>	10.4. Flash Memory Characteristics .....	98
4.1. Introduction .....	27	10.5. External Clock Operation Timing .....	99
4.2. Interrupt Vector Table .....	27	10.6. Phase Locked Loop Timing .....	99
4.3. Program Map .....	29	10.7. Relaxation Oscillator Timing .....	100
4.4. Data Map .....	30	10.8. Reset, Stop, Wait, Mode Select, and Interrupt Timing .....	101
4.5. EOnCE Memory Map .....	31	10.9. Serial Peripheral Interface (SPI) Timing ..	102
4.6. Peripheral Memory Mapped Registers ...	32	10.10. Quad Timer Timing .....	105
		10.11. Serial Communication Interface (SCI) Timing .....	106
<b>Part 5: Interrupt Controller (ITCN)</b> .....	<b>42</b>	10.12. Inter-Integrated Circuit Interface (I2C) Timing .....	107
5.1. Introduction .....	42	10.13. JTAG Timing .....	108
5.2. Features .....	42	10.14. Analog-to-Digital Converter (ADC) Parameters	109
5.3. Functional Description .....	42	10.15. Equivalent Circuit for ADC Inputs .....	110
5.4. Block Diagram .....	44	10.16. Power Consumption .....	111
5.5. Operating Modes .....	44		
5.6. Register Descriptions .....	45		
5.7. Resets .....	61		
<b>Part 6: System Integration Module (SIM)</b> ...	<b>62</b>	<b>Part 11: Packaging</b> .....	<b>113</b>
6.1. Introduction .....	62	11.1. 56F8014 Package and Pin-Out Information	113
6.2. Features .....	62		
6.3. Register Descriptions .....	63	<b>Part 12: Design Considerations</b> .....	<b>116</b>
6.4. Clock Generation Overview .....	76	12.1. Thermal Design Considerations .....	116
6.5. Power-Down Modes .....	77	12.2. Electrical Design Considerations .....	117
6.6. Resets .....	78		
6.7. Clocks .....	80	<b>Part 13: Ordering Information</b> .....	<b>119</b>
6.8. Interrupts .....	81		
		<b>Part 14: Appendix</b> .....	<b>120</b>

# Part 1 Overview

## 1.1 56F8014 Features

### 1.1.1 Digital Signal Controller Core

- Efficient 16-bit 56800E family Digital Signal Controller (DSC) engine with dual Harvard architecture
- As many as 32 Million Instructions Per Second (MIPS) at 32MHz core frequency
- Single-cycle 16 × 16-bit parallel Multiplier-Accumulator (MAC)
- Four 36-bit accumulators, including extension bits
- Arithmetic and logic multi-bit shifter
- Parallel instruction set with unique DSP addressing modes
- Hardware DO and REP loops
- Three internal address buses
- Four internal data buses
- Instruction set supports both DSP and controller functions
- Controller-style addressing modes and instructions for compact code
- Efficient C compiler and local variable support
- Software subroutine and interrupt stack with depth limited only by memory
- JTAG/EOnCE debug programming interface

### 1.1.2 Memory

- Harvard architecture permits as many as three simultaneous accesses to program and data memory
- Flash security and protection
- On-chip memory, including a low-cost, high-volume Flash solution
  - 16KB of Program Flash
  - 4KB of Unified Data/Program RAM
- EEPROM emulation capability

### 1.1.3 Peripheral Circuits for 56F8014

- One Pulse Width Modulator (PWM) module with five PWM outputs and three Fault inputs; fault-tolerant design with dead time insertion; supports both center-aligned and edge-aligned modes
- One eight-input, 12-bit, Analog-to-Digital Converter (ADC), which support two simultaneous conversions with dual, 4-pin multiplexed inputs; ADC and PWM modules can be synchronized through Timer Channels 2 and 3
- One 16-bit Quad Timer module (TMR) totaling four pins: Timer works in conjunction with the PWM and ADC
- One Serial Communication Interface (SCI) with LIN Slave functionality
- One Serial Peripheral Interface (SPI)
- Computer Operating Properly (COP)/Watchdog timer

- 26 General Purpose I/O (GPIO) pins
- Integrated Power-On Reset and Low-Voltage Interrupt Module
- One Inter-Integrated Circuit (I<sup>2</sup>C) port
- JTAG/Enhanced On-Chip Emulation (OnCE) for unobtrusive, processor speed-independent, real-time debugging
- Fixed Phase Lock Loop (PLL)
- On-chip relaxation oscillator

#### 1.1.4 Energy Information

- Fabricated in high-density CMOS with 5V-tolerant, TTL-compatible digital inputs
- On-chip regulators for digital and analog circuitry to lower cost and reduce noise
- Wait and Stop modes available
- ADC smart power management
- Each peripheral can be individually disabled to save power

## 1.2 56F8014 Description

The 56F8014 is a member of the 56800E core-based family of Digital Signal Controllers (DSCs). It combines, on a single chip, the processing power of a DSP and the functionality of a microcontroller with a flexible set of peripherals to create an extremely cost-effective solution. Because of its low cost, configuration flexibility, and compact program code, the 56F8014 is well-suited for many applications. The 56F8014 includes many peripherals that are especially useful for industrial control, motion control, home appliances, general purpose inverters, smart sensors, fire and security systems, power management, and medical monitoring applications.

The 56800E core is based on a Harvard-style architecture consisting of three execution units operating in parallel, allowing as many as six operations per instruction cycle. The MCU-style programming model and optimized instruction set allow straightforward generation of efficient, compact DSP and control code. The instruction set is also highly efficient for C compilers to enable rapid development of optimized control applications.

The 56F8014 supports program execution from internal memories. Two data operands can be accessed from the on-chip data RAM per instruction cycle. The 56F8014 also offers up to 26 General Purpose Input/Output (GPIO) lines, depending on peripheral configuration.

The 56F8014 Digital Signal Controller includes 16KB of Program Flash and 4KB of Unified Data/Program RAM. Program Flash memory can be independently bulk erased or erased in pages. Program Flash page erase size is 512 Bytes/256 Words.

A key application-specific feature of the 56F8014 is the inclusion of one Pulse Width Modulator (PWM) module. This module incorporates three complementary, individually programmable PWM signal output pairs and is also capable of supporting five independent PWM functions to enhance motor control functionality. Complementary operation permits programmable dead time insertion, and separate top and bottom output polarity control. The up-counter value is programmable to support a continuously variable

PWM frequency. Edge-aligned and center-aligned synchronous pulse width control (0% to 100% modulation) is supported. The device is capable of controlling most motor types: ACIM (AC Induction Motors), both BDC and BLDC (Brush and Brushless DC motors), SRM and VRM (Switched and Variable Reluctance Motors), and stepper motors. The PWM incorporates fault protection and cycle-by-cycle current limiting with sufficient output drive capability to directly drive standard optoisolators. A “smoke-inhibit”, write-once protection feature for key parameters is also included. A patented PWM waveform distortion correction circuit is also provided. Each PWM is double-buffered and includes interrupt controls to permit integral reload rates to be programmable from 1/2 (center-aligned mode only) to 16. The PWM module provides reference outputs to synchronize the Analog-to-Digital Converter (ADC) through Quad Timer, Channels 2 and 3.

This Digital Signal Controller also provides a full set of standard programmable peripherals that include one Serial Communications Interface (SCI), one Serial Peripheral Interface (SPI), one Quad Timer, and one Inter-Integrated Circuit (I<sup>2</sup>C) interface. Any of these interfaces can also be used as General Purpose Input/Outputs (GPIOs).

## 1.3 Award-Winning Development Environment

Processor Expert<sup>TM</sup> (PE) provides a Rapid Application Design (RAD) tool that combines easy-to-use component-based software application creation with an expert knowledge system.

The CodeWarrior Integrated Development Environment is a sophisticated tool for code navigation, compiling, and debugging. A complete set of evaluation modules (EVMs), demonstration board kit and development system cards will support concurrent engineering. Together, PE, CodeWarrior and EVMs create a complete, scalable tools solution for easy, fast, and efficient development.

## 1.4 Architecture Block Diagram

The 56F8014’s architecture is shown in [Figure 1-1](#), [Figure 1-2](#), and [Figure 1-3](#). [Figure 1-1](#) illustrates how the 56800E system buses communicate with internal memories and the IPBus Bridge. [Table 1-1](#) lists the internal buses in the 56800E architecture and provides a brief description of their function. [Figure 1-2](#) and [Figure 1-3](#) show the peripherals and control blocks connected to the IPBus Bridge. The figures do not show the on-board regulator and power and ground signals. They also do not show the multiplexing between peripherals or the dedicated GPIOs. Please see [Part 2 Signal/Connection Descriptions](#) to see which signals are multiplexed with those of other peripherals.

### 1.4.1 PWM, TMR and ADC Connections

[Figure 1-3](#) shows the over/under voltage connections from the ADC to the PWM and the connections to the PWM from the TMR and GPIO. These signals can control the PWM outputs in a similar manner to the over/under voltage control signals. See the [56F8000 Peripheral Reference Manual](#) for additional information.

The PWM\_reload\_sync output can be connected to the TMR channel 3 input and the TMR channels 2 and 3 outputs are connected to the ADC sync inputs. TMR channel 3 output is connected to SYNC0 and TMR channel 2 is connected to SYNC1. These are controlled by bits in the SIM Control Register; see [Section 6.3.1](#).

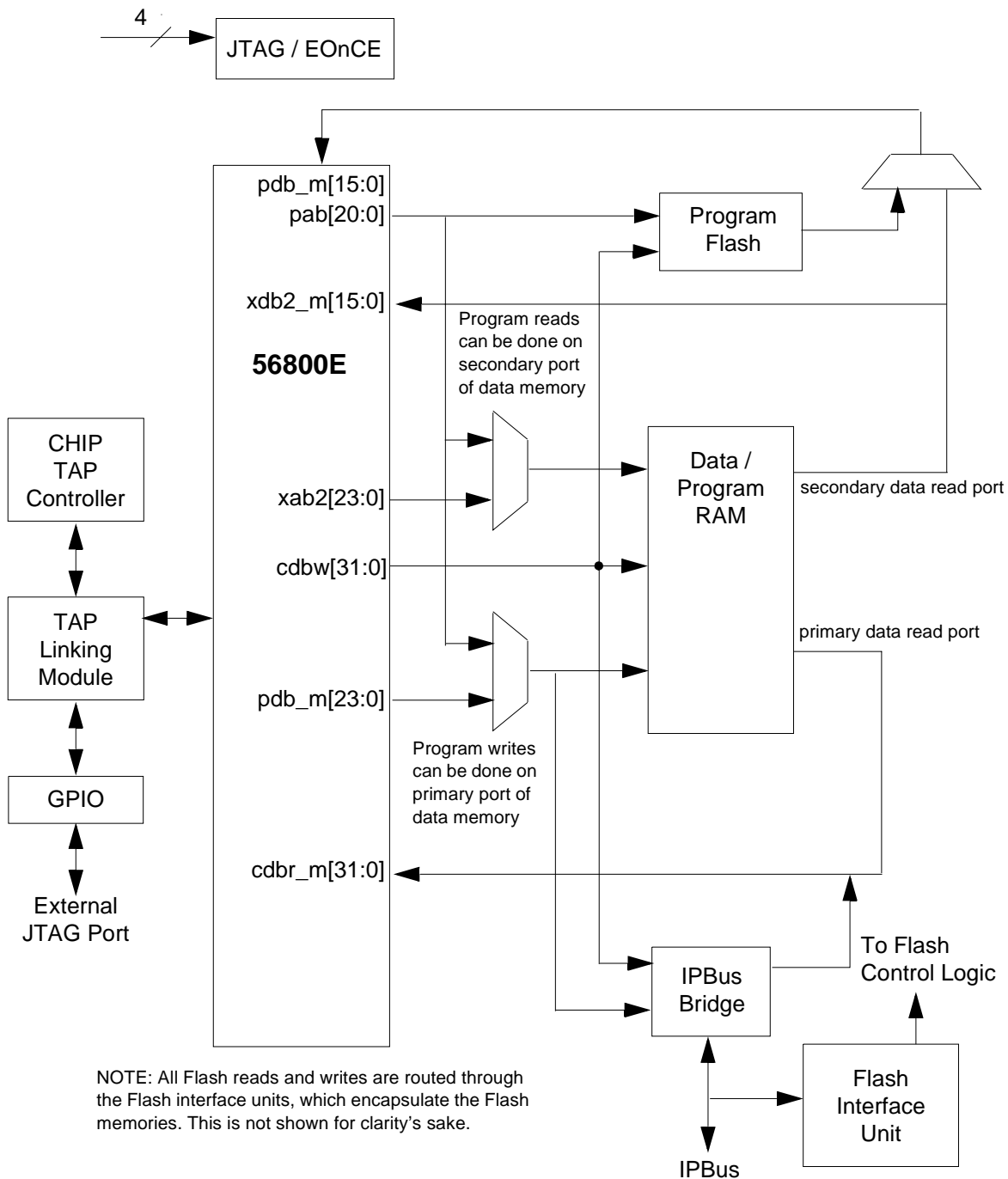

**Figure 1-1 System Bus Interfaces**

**Note:** Flash memories are encapsulated within the Flash Interface Unit (FIU). Flash control is accomplished by the I/O to the FIU over the peripheral bus, while reads and writes are completed between the core and the Flash memories.

**Note:** The primary data RAM port is 32 bits wide. Other data ports are 16 bits.

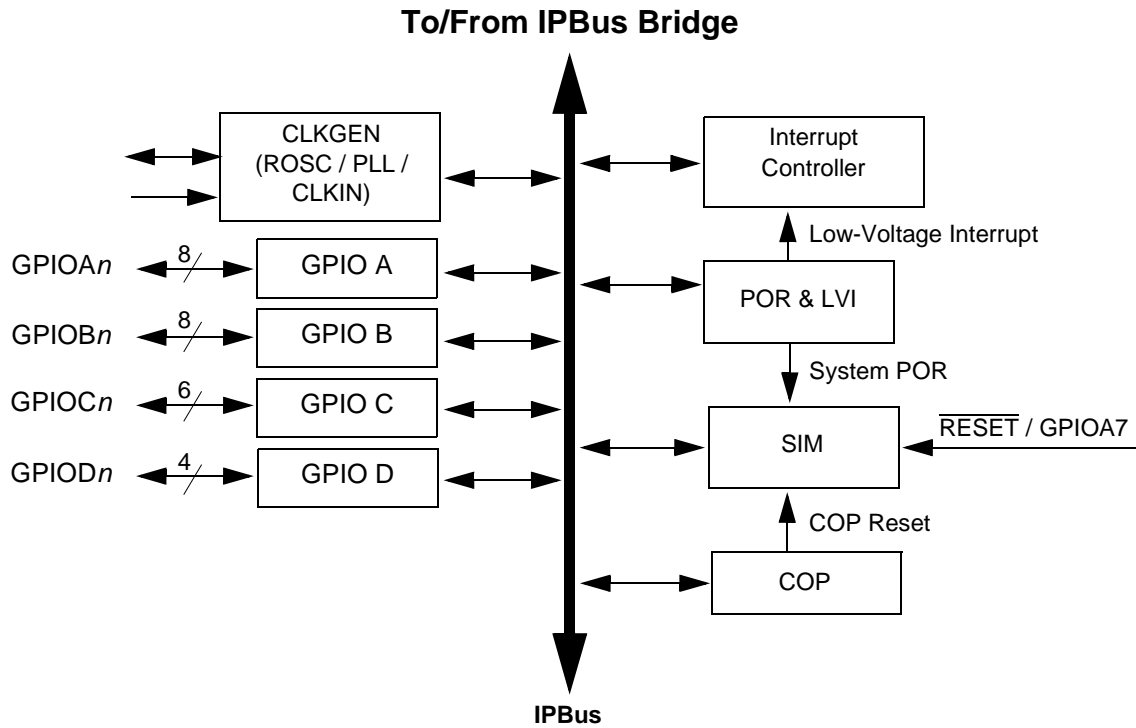

**Figure 1-2 Peripheral Subsystem**

**Table 1-1 Bus Signal Names**

Name	Function
<b>Program Memory Interface</b>	
pab[20:0]	Program memory address bus. Data is returned on pdb_m bus.
pdb_m[15:0]	Program data bus for instruction word fetches or read operations.
cdbw[15:0]	Primary core data bus used for program memory writes. (Only these 16 bits of the cdbw[31:0] bus are used for writes to program memory.)
<b>Primary Data Memory Interface Bus</b>	
xab1[23:0]	Primary data address bus. Capable of addressing bytes <sup>1</sup> , words, and long data types. Data is written on cdbw and returned on cdb_r_m. Also used to access memory-mapped I/O.
cdbr_m[31:0]	Primary core data bus for memory reads. Addressed via xab1 bus.
cdbw[31:0]	Primary core data bus for memory writes. Addressed via xab1 bus.
<b>Secondary Data Memory Interface</b>	
xab2[23:0]	Secondary data address bus used for the second of two simultaneous accesses. Capable of addressing only words. Data is returned on xdb2_m.
xdb2_m[15:0]	Secondary data bus used for secondary data address bus xab2 in the dual memory reads.

1. Byte accesses can only occur in the bottom half of the memory address space. The Most Significant Bit (MSB) of the address will be forced to 0.

(Continued from Figure 1-2)

To/From IPBus Bridge

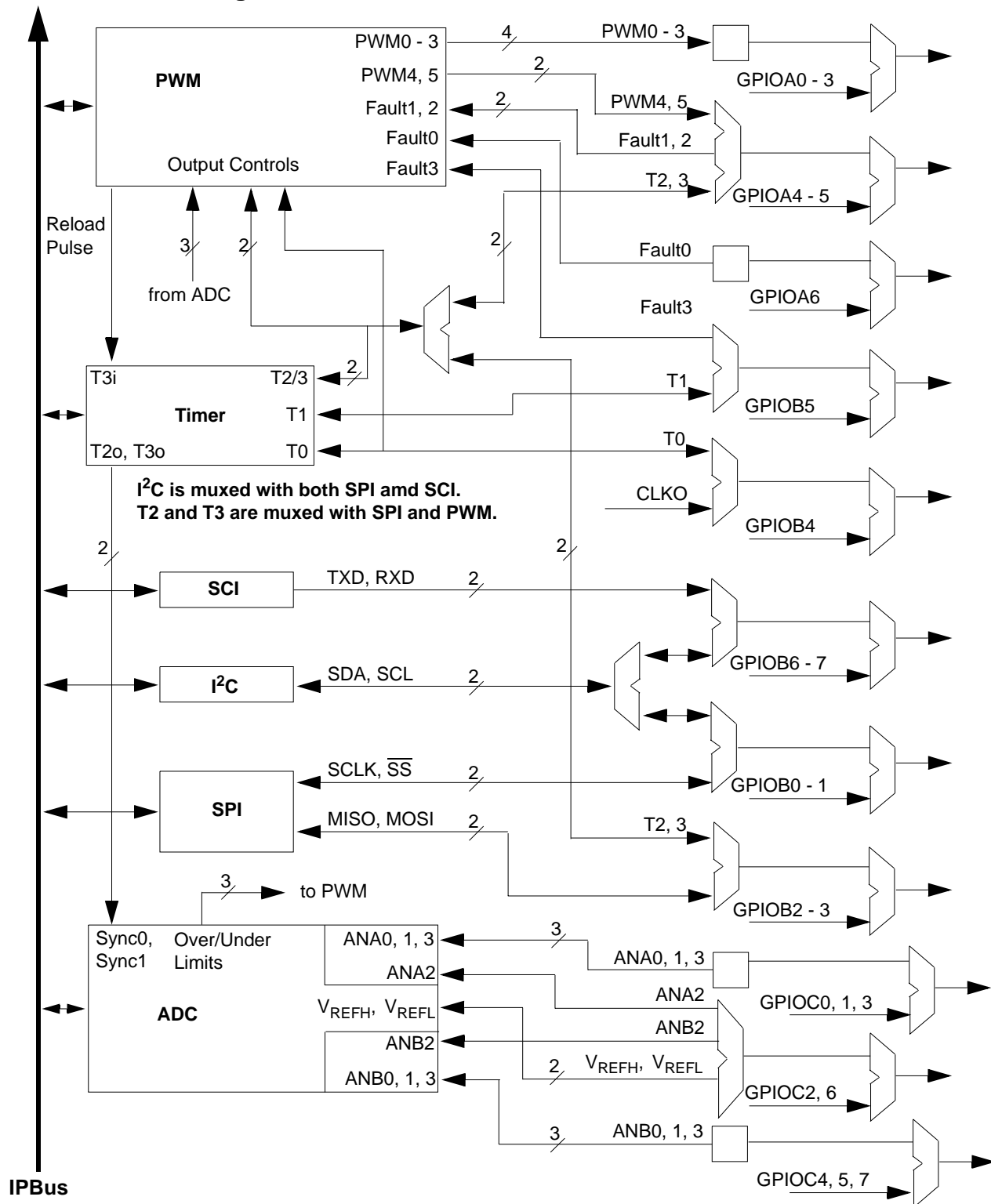

Figure 1-3 56F8014 Peripheral I/O Pin-Out

## 1.5 Product Documentation

The documents listed in [Table 1-2](#) are required for a complete description and proper design with the 56F8014. Documentation is available from local Freescale distributors, Freescale Semiconductor sales offices, Freescale Literature Distribution Centers, or online at:

<http://www.freescale.com>

**Table 1-2 56F8014 Chip Documentation**

Topic	Description	Order Number
DSP56800E Reference Manual	Detailed description of the 56800E family architecture, 16-bit Digital Signal Controller core processor, and the instruction set	DSP56800ERM
56F8000 Peripheral Reference Manual	Detailed description of peripherals of the 56F8000 family of devices	MC56F8000RM
56F801x Serial Bootloader User Guide	Detailed description of the Serial Bootloader in the 56F801x family of devices	56F801xBLUG
56F8014 Technical Data Sheet	Electrical and timing specifications, pin descriptions, and package descriptions (this document)	MC56F8014
56F8014 Errata	Details any chip issues that might be present	MC56F8014E

## 1.6 Data Sheet Conventions

This data sheet uses the following conventions:

$\overline{\text{OVERBAR}}$  This is used to indicate a signal that is active when pulled low. For example, the  $\overline{\text{RESET}}$  pin is active when low.

“asserted” A high true (active high) signal is high or a low true (active low) signal is low.

“deasserted” A high true (active high) signal is low or a low true (active low) signal is high.

Examples:	Signal/Symbol	Logic State	Signal State	Voltage <sup>1</sup>
	$\overline{\text{PIN}}$	True	Asserted	$V_{\text{IL}}/V_{\text{OL}}$
	$\overline{\text{PIN}}$	False	Deasserted	$V_{\text{IH}}/V_{\text{OH}}$
	PIN	True	Asserted	$V_{\text{IH}}/V_{\text{OH}}$
	PIN	False	Deasserted	$V_{\text{IL}}/V_{\text{OL}}$

1. Values for  $V_{\text{IL}}$ ,  $V_{\text{OL}}$ ,  $V_{\text{IH}}$ , and  $V_{\text{OH}}$  are defined by individual product specifications.

## Part 2 Signal/Connection Descriptions

### 2.1 Introduction

The input and output signals of the 56F8014 are organized into functional groups, as detailed in [Table 2-1](#). [Table 2-2](#) summarizes all device pins. In [Table 2-2](#), each table row describes the signal or signals present on a pin, sorted by pin number.

**Table 2-1 Functional Group Pin Allocations**

Functional Group	Number of Pins
Power ( $V_{DD}$ or $V_{DDA}$ )	2
Ground ( $V_{SS}$ or $V_{SSA}$ )	3
Supply Capacitors	1
Reset	1
Pulse Width Modulator (PWM) Ports <sup>1</sup>	5
Serial Peripheral Interface (SPI) Ports <sup>2</sup>	4
Analog-to-Digital Converter (ADC) Ports	8
Timer Module Ports <sup>3</sup>	2
Serial Communications Interface (SCI) Ports <sup>4</sup>	2
JTAG/Enhanced On-Chip Emulation (EOnCE)	4

1. Pins in this section can function as TMR and GPIO.
2. Pins in this section can function as TMR, I<sup>2</sup>C, and GPIO.
3. Pins can function as PWM and GPIO.
4. Pins in this section can function as I<sup>2</sup>C and GPIO.

Table 2-2 56F8014 Pins

			Peripherals:									
LQFP Pin #	Pin Name	Signal Name	GPIO	I2C	SCI	SPI	ADC	PWM	Quad Timer	Power & Ground	JTAG	Misc
1	<b>GPIOB1</b>	GPIOB1, $\overline{SS}$ , SDA	<b>B1</b>	SDA		$\overline{SS}$						
2	<b>GPIOB7</b>	GPIOB7, TXD, SCL	<b>B7</b>	SCL	TXD							
3	<b>GPIOB5</b>	GPIOB5, T1, FAULT3	<b>B5</b>					FAULT3	T1			
4	<b>ANB0</b>	ANB0, GPIOC4	C4				<b>ANB0</b>					
5	<b>ANB1</b>	ANB1, GPIOC5	C5				<b>ANB1</b>					
6	<b>ANB2</b>	ANB2, $V_{REFL}$ , GPIOC6	C6				<b>ANB2</b> , $V_{REFL}$					
7	<b>ANB3</b>	ANB3, GPIOC7	C7				<b>ANB3</b>					
8	<b>VDDA</b>	$V_{DDA}$								$V_{DDA}$		
9	<b>VSSA</b>	$V_{SSA}$								$V_{SSA}$		
10	<b>ANA3</b>	ANA3, GPIOC3	C3				<b>ANA3</b>					
11	<b>ANA2</b>	ANA2, $V_{REFH}$ , GPIOC2	C2				<b>ANA2</b> , $V_{REFH}$					
12	<b>ANA1</b>	ANA1, GPIOC1	C1				<b>ANA1</b>					
13	<b>ANA0</b>	ANA0, GPIOC0	C0				<b>ANA0</b>					
14	<b>VSS_IO</b>	$V_{SS\_IO}$								$V_{SS\_IO}$		
15	<b>TCK</b>	TCK, GPIOD2	D2								<b>TCK</b>	
16	<b>RESET</b>	$\overline{RESET}$ , GPIOA7	A7									$\overline{RESET}$
17	<b>GPIOB3</b>	GPIOB3, MOSI, T3	<b>B3</b>			MOSI			T3			
18	<b>GPIOB2</b>	GPIOB2, MISO, T2	<b>B2</b>			MISO			T2			
19	<b>GPIOB4</b>	GPIOB4, T0, CLKO	<b>B4</b>						T0			CLKO
20	<b>GPIOA5</b>	GPIOA5, PWM5, FAULT2, T3	<b>A5</b>					PWM5, FAULT2	T3			
21	<b>GPIOB0</b>	GPIOB0, SCLK, SCL	<b>B0</b>	SCL		SCLK						
22	<b>GPIOA4</b>	GPIOA4, PWM4, FAULT1, T2	<b>A4</b>					PWM4, FAULT1	T2			
23	<b>GPIOA2</b>	GPIOA2, PWM2	<b>A2</b>					PWM2				

**Table 2-2 56F8014 Pins (Continued)**

LQFP Pin #	Pin Name	Signal Name	Peripherals:										
			GPIO	I2C	SCI	SPI	ADC	PWM	Quad Timer	Power & Ground	JTAG	Misc	
24	<b>VCAP</b>	V <sub>CAP</sub>									V <sub>CAP</sub>		
25	<b>VDD_IO</b>	V <sub>DD_IO</sub>									V <sub>DD_IO</sub>		
26	<b>VSS_IO</b>	V <sub>SS_IO</sub>									V <sub>SS_IO</sub>		
27	<b>GPIOA1</b>	GPIOA1, PWM1	<b>A1</b>						PWM1				
28	<b>GPIOA0</b>	GPIOA0, PWM0	<b>A0</b>						PWM0				
29	<b>TDI</b>	TDI, GPIOD0	D0									<b>TDI</b>	
30	<b>TMS</b>	TMS, GPIOD3	D3									<b>TMS</b>	
31	<b>TDO</b>	TDO, GPIOD1	D1									<b>TDO</b>	
32	<b>GPIOB6</b>	GPIOB6, RXD, SDA, CLKIN	<b>B6</b>	SDA	RXD								CLKIN

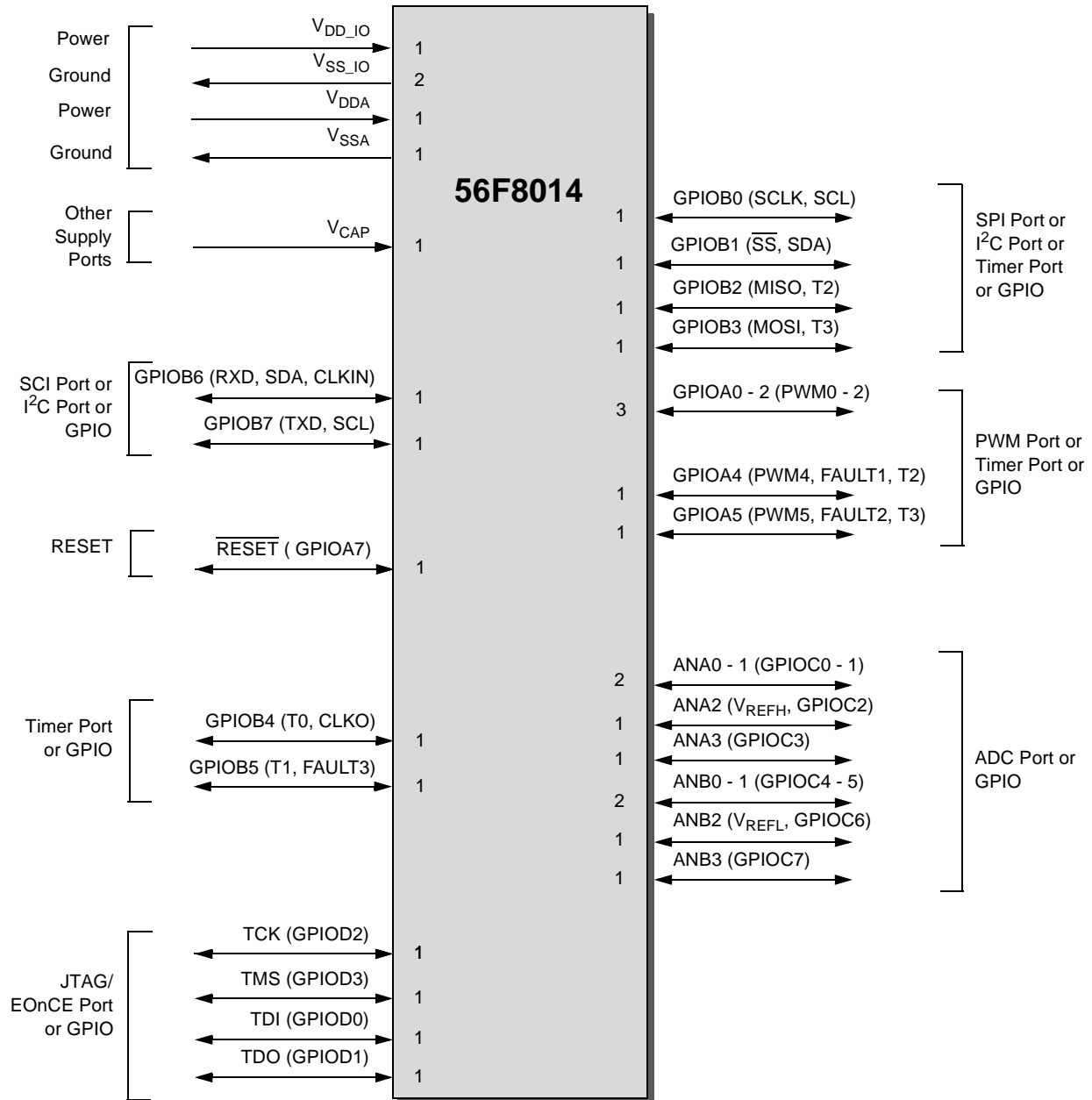

Figure 2-1 56F8014 Signals Identified by Functional Group (32-Pin LQFP)

## 2.2 56F8014 Signal Pins

After reset, each pin is configured for its primary function (listed first). Any alternate functionality must be programmed.

**Table 2-3 56F8014 Signal and Package Information for the 32-Pin LQFP**

Signal Name	LQFP Pin No.	Type	State During Reset	Signal Description
V <sub>DD_IO</sub>	25	Supply	Supply	<b>I/O Power</b> — This pin supplies 3.3V power to the chip I/O interface.
V <sub>SS_IO</sub>	14	Supply	Supply	<b>V<sub>SS</sub></b> — These pins provide ground for chip logic and I/O drivers.
V <sub>SS_IO</sub>	26			
V <sub>DDA</sub>	8	Supply	Supply	<b>ADC Power</b> — This pin supplies 3.3V power to the ADC modules. It must be connected to a clean analog power supply.
V <sub>SSA</sub>	9	Supply	Supply	<b>ADC Analog Ground</b> — This pin supplies an analog ground to the ADC modules.
V <sub>CAP</sub>	24	Supply	Supply	<b>V<sub>CAP</sub></b> — Connect this pin to a 4.4μF or greater bypass capacitor in order to bypass the core voltage regulator, required for proper chip operation. See <a href="#">Section 10.2.1</a> .
<b>GPIOB6</b>  (RXD)  (SDA <sup>1</sup> )  (CLKIN)	32	Input/ Output  Input  Input/ Output  Input	Input, pulled high internally	<p><b>Port B GPIO</b> — This GPIO pin can be individually programmed as an input or output pin.</p> <p><b>Receive Data</b> — SCI receive data input.</p> <p><b>Serial Data</b> — This pin serves as the I<sup>2</sup>C serial data line.</p> <p><b>Clock Input</b> — This pin serves as an optional external clock input.</p> <p>After reset, the default state is GPIOB6. The peripheral functionality is controlled via the SIM (See <a href="#">Section 6.3.8</a>) and the CLKMODE bit of the OCCS Oscillator Control Register.</p>
1. This signal is also brought out on the GPIOB1 pin.				

Return to [Table 2-2](#)

**Table 2-3 56F8014 Signal and Package Information for the 32-Pin LQFP (Continued)**

Signal Name	LQFP Pin No.	Type	State During Reset	Signal Description
<b>GPIOB7</b>  (TXD)  (SCL <sup>2</sup> )	2	Input/ Output  Input/ Output  Input/ Output	Input, pulled high internally	<b>Port B GPIO</b> — This GPIO pin can be individually programmed as an input or output pin.  <b>Transmit Data</b> — SCI transmit data output or transmit / receive in single wire operation.  <b>Serial Clock</b> — This pin serves as the I <sup>2</sup> C serial clock.  After reset, the default state is GPIOB7. The peripheral functionality is controlled via the SIM. See <a href="#">Section 6.3.8</a> .
<b>2. This signal is also brought out on the GPIOB0 pin.</b>				
<b>RESET</b>  (GPIOA7)	16	Input  Input/Open Drain Output	Input, pulled high internally	<b>Reset</b> — This input is a direct hardware reset on the processor. When <b>RESET</b> is asserted low, the chip is initialized and placed in the reset state. A Schmitt trigger input is used for noise immunity. The internal reset signal will be deasserted synchronous with the internal clocks after a fixed number of internal clocks.  <b>Port A GPIO</b> — This GPIO pin can be individually programmed as an input or open drain output pin. Note that <b>RESET</b> functionality is disabled in this mode and the chip can only be reset via POR, COP reset, or software reset.  After reset, the default state is <b>RESET</b> .
<b>GPIOB4</b>  (T0)  (CLKO)	19	Input/ Output  Input/ Output  Output	Input, pulled high internally	<b>Port B GPIO</b> — This GPIO pin can be individually programmed as an input or output pin.  <b>T0</b> — Timer, Channel 0  <b>Clock Output</b> — This is a buffered clock signal. Using the SIM_CLKO Select Register (SIM_CLKOSR), this pin can be programmed as any of the following: disabled (logic 0), CLK_MSTR (system clock), IPBus clock, or oscillator output. See <a href="#">Section 6.3.7</a> .  After reset, the default state is GPIOB4. The peripheral functionality is controlled via the SIM. See <a href="#">Section 6.3.8</a> .

Return to [Table 2-2](#)

**Table 2-3 56F8014 Signal and Package Information for the 32-Pin LQFP (Continued)**

Signal Name	LQFP Pin No.	Type	State During Reset	Signal Description
<b>GPIOB5</b>  (T1)  (FAULT3)	3	Input/ Output  Input/ Output  Output	Input, pulled high internally	<p><b>Port B GPIO</b> — This GPIO pin can be individually programmed as an input or output pin.</p> <p><b>T1</b> — Timer, Channel 1</p> <p><b>FAULT3</b> — This fault input pin is used for disabling selected PWM outputs in cases where fault conditions originate off-chip.</p> <p>After reset, the default state is GPIOB5. The peripheral functionality is controlled via the SIM. See <a href="#">Section 6.3.8</a>.</p>
<b>TCK</b>  (GPIOD2)	15	Input  Input/ Output	Input, pulled high internally	<p><b>Test Clock Input</b> — This input pin provides a gated clock to synchronize the test logic and shift serial data to the JTAG/EOnCE port. The pin is connected internally to a pull-up resistor. A Schmitt trigger input is used for noise immunity.</p> <p><b>Port D GPIO</b> — This GPIO pin can be individually programmed as an input or output pin.</p> <p>After reset, the default state is TCK.</p>
<b>TMS</b>  (GPIOD3)	30	Input  Input/ Output	Input, pulled high internally	<p><b>Test Mode Select Input</b> — This input pin is used to sequence the JTAG TAP controller's state machine. It is sampled on the rising edge of TCK and has an on-chip pull-up resistor.</p> <p><b>Port D GPIO</b> — This GPIO pin can be individually programmed as an input or output pin.</p> <p>After reset, the default state is TMS.</p>
<b>TDI</b>  (GPIOD0)	29	Input  Input/ Output	Input, pulled high internally	<p><b>Test Data Input</b> — This input pin provides a serial input data stream to the JTAG/EOnCE port. It is sampled on the rising edge of TCK and has an on-chip pull-up resistor.</p> <p><b>Port D GPIO</b> — This GPIO pin can be individually programmed as an input or output pin.</p> <p>After reset, the default state is TDI.</p>

Return to [Table 2-2](#)

**Table 2-3 56F8014 Signal and Package Information for the 32-Pin LQFP (Continued)**

Signal Name	LQFP Pin No.	Type	State During Reset	Signal Description
<b>TDO</b>  (GPIOD1)	31	Output  Input/ Output	Tri-stated, pulled high internally	<b>Test Data Output</b> — This tri-stateable output pin provides a serial output data stream from the JTAG/EOnCE port. It is driven in the shift-IR and shift-DR controller states, and changes on the falling edge of TCK.  <b>Port D GPIO</b> — This GPIO pin can be individually programmed as an input or output pin.  After reset, the default state is TDO.
<b>GPIOB0</b>  (SCLK)  (SCL <sup>3</sup> )	21	Input/ Output  Input/ Output  Input/ Output	Input, pulled high internally	<b>Port B GPIO</b> — This GPIO pin can be individually programmed as an input or output pin.  <b>SPI Serial Clock</b> — In the master mode, this pin serves as an output, clocking slaved listeners. In slave mode, this pin serves as the data clock input. A Schmitt trigger input is used for noise immunity.  <b>Serial Data</b> — This pin serves as the I <sup>2</sup> C serial clock.  After reset, the default state is GPIOB0. The peripheral functionality is controlled via the SIM. See <a href="#">Section 6.3.8</a> .
3. This signal is also brought out on the GPIOB7 pin.				
<b>GPIOB1</b>  ( $\overline{SS}$ )  (SDA <sup>4</sup> )	1	Input/ Output  Input  Input/ Output	Input, pulled high internally	<b>Port B GPIO</b> — This GPIO pin can be individually programmed as an input or output pin.  <b>SPI Slave Select</b> — $\overline{SS}$ is used in slave mode to indicate to the SPI module that the current transfer is to be received.  <b>Serial Clock</b> — This pin serves as the I <sup>2</sup> C serial data line.  After reset, the default state is GPIOB1. The peripheral functionality is controlled via the SIM. See <a href="#">Section 6.3.8</a> .
4. This signal is also brought out on the GPIOB6 pin.				

Return to [Table 2-2](#)

**Table 2-3 56F8014 Signal and Package Information for the 32-Pin LQFP (Continued)**

Signal Name	LQFP Pin No.	Type	State During Reset	Signal Description
<b>GPIOB2</b>	18	Input/ Output	Input, pulled high internally	<b>Port B GPIO</b> — This GPIO pin can be individually programmed as an input or output pin.
<b>(MISO)</b>		Input/ Output		<b>SPI Master In/Slave Out</b> — This serial data pin is an input to a master device and an output from a slave device. The MISO line of a slave device is placed in the high-impedance state if the slave device is not selected. The slave device places data on the MISO line a half-cycle before the clock edge the master device uses to latch the data.
<b>(T2<sup>5</sup>)</b>		Input/ Output		<b>T2</b> — Timer, Channel 2  After reset, the default state is GPIOB2. The peripheral functionality is controlled via the SIM. See <a href="#">Section 6.3.8</a> .
<b>5. This signal is also brought out on the GPIOA4 pin.</b>				
<b>GPIOB3</b>	17	Input/ Output	Input, pulled high internally	<b>Port B GPIO</b> — This GPIO pin can be individually programmed as an input or output pin.
<b>(MOSI)</b>		Input/ Output		<b>SPI Master Out/Slave In</b> — This serial data pin is an output from a master device and an input to a slave device. The master device places data on the MOSI line a half-cycle before the clock edge the slave device uses to latch the data.
<b>(T3<sup>6</sup>)</b>		Input/ Output		<b>T3</b> — Timer, Channel 3  After reset, the default state is GPIOB3. The peripheral functionality is controlled via the SIM. See <a href="#">Section 6.3.8</a> .
<b>6. This signal is also brought out on the GPIOA5 pin.</b>				
<b>GPIOA0</b>	28	Input/ Output	Input, pulled high internally	<b>Port A GPIO</b> — This GPIO pin can be individually programmed as an input or output pin.
<b>(PWM0)</b>		Output		<b>PWM0</b> — This is one of the six PWM output pins.  After reset, the default state is GPIOA0.

Return to [Table 2-2](#)

**Table 2-3 56F8014 Signal and Package Information for the 32-Pin LQFP (Continued)**

Signal Name	LQFP Pin No.	Type	State During Reset	Signal Description
<b>GPIOA1</b>  <b>(PWM1)</b>	27	Input/ Output  Output	Input, pulled high internally	<b>Port A GPIO</b> — This GPIO pin can be individually programmed as an input or output pin.  <b>PWM1</b> — This is one of the six PWM output pins.  After reset, the default state is GPIOA1.
<b>GPIOA2</b>  <b>(PWM2)</b>	23	Input/ Output  Output	Input, pulled high internally	<b>Port A GPIO</b> — This GPIO pin can be individually programmed as an input or output pin.  <b>PWM2</b> — This is one of the six PWM output pins.  After reset, the default state is GPIOA2.
<b>GPIOA4</b>  <b>(PWM4)</b>  <b>(FAULT1)</b>  <b>(T2<sup>7</sup>)</b>	22	Input/ Output  Output  Input  Input/ Output	Input, pulled high internally	<b>Port A GPIO</b> — This GPIO pin can be individually programmed as an input or output pin.  <b>PWM4</b> — This is one of the six PWM output pins.  <b>Fault1</b> — This fault input pin is used for disabling selected PWM outputs in cases where fault conditions originate off-chip.  <b>T2</b> — Timer, Channel 2  After reset, the default state is GPIOA4. The peripheral functionality is controlled via the SIM. See <a href="#">Section 6.3.8</a> .
<b>7. This signal is also brought out on the GPIOB2 pin.</b>				
<b>GPIOA5</b>  <b>(PWM5)</b>  <b>(FAULT2)</b>  <b>(T3<sup>8</sup>)</b>	20	Input/ Output  Output  Input/ Output  Input/ Output	Input, pulled high internally	<b>Port A GPIO</b> — This GPIO pin can be individually programmed as an input or output pin.  <b>PWM5</b> — This is one of the six PWM output pins.  <b>Fault2</b> — This fault input pin is used for disabling selected PWM outputs in cases where fault conditions originate off-chip.  <b>T3</b> — Timer, Channel 3  After reset, the default state is GPIOA5. The peripheral functionality is controlled via the SIM. See <a href="#">Section 6.3.8</a> .
<b>8. This signal is also brought out on the GPIOB3 pin.</b>				

Return to [Table 2-2](#)

**Table 2-3 56F8014 Signal and Package Information for the 32-Pin LQFP (Continued)**

Signal Name	LQFP Pin No.	Type	State During Reset	Signal Description
<b>ANA0</b>  <b>(GPIOC0)</b>	13	Input  Input/ Output	Analog Input	<b>ANA0</b> — Analog input to ADC A, channel 0  <b>Port C GPIO</b> — This GPIO pin can be individually programmed as an input or output pin.  After reset, the default state is ANA0.
<b>ANA1</b>  <b>(GPIOC1)</b>	12	Input  Input/ Output	Analog Input	<b>ANA1</b> — Analog input to ADC A, channel 1  <b>Port C GPIO</b> — This GPIO pin can be individually programmed as an input or output pin.  After reset, the default state is ANA1.
<b>ANA2</b>  <b>(V<sub>REFH</sub>)</b>  <b>(GPIOC2)</b>	11	Input  Input  Input/ Output	Analog Input	<b>ANA2</b> — Analog input to ADC A, channel 2  <b>V<sub>REFH</sub></b> — Analog reference voltage high  <b>Port C GPIO</b> — This GPIO pin can be individually programmed as an input or output pin.  After reset, the default state is ANA2.
<b>ANA3</b>  <b>(GPIOC3)</b>	10	Input  Input/ Output	Analog Input	<b>ANA3</b> — Analog input to ADC A, channel 3  <b>Port C GPIO</b> — This GPIO pin can be individually programmed as an input or output pin.  After reset, the default state is ANA3.
<b>ANB0</b>  <b>(GPIOC4)</b>	4	Input  Input/ Output	Analog Input	<b>ANB0</b> — Analog input to ADC B, channel 0  <b>Port C GPIO</b> — This GPIO pin can be individually programmed as an input or output pin.  After reset, the default state is ANB0.

Return to [Table 2-2](#)

**Table 2-3 56F8014 Signal and Package Information for the 32-Pin LQFP (Continued)**

Signal Name	LQFP Pin No.	Type	State During Reset	Signal Description
<b>ANB1</b>  <b>(GPIOC5)</b>	5	Input  Input/ Output	Analog Input	<b>ANB1</b> — Analog input to ADC B, channel 1  <b>Port C GPIO</b> — This GPIO pin can be individually programmed as an input or output pin.  After reset, the default state is ANB1.
<b>ANB2</b>  <b>(V<sub>REFL</sub>)</b>  <b>(GPIOC6)</b>	6	Input  Input  Input/ Output	Analog Input	<b>ANB2</b> — Analog input to ADC B, channel 2  <b>V<sub>REFL</sub></b> — Analog reference voltage low. This should normally be connected to a low-noise V <sub>SS</sub> .  <b>Port C GPIO</b> — This GPIO pin can be individually programmed as an input or output pin.  After reset, the default state is ANB2.
<b>ANB3</b>  <b>(GPIOC7)</b>	7	Input  Input/ Output	Analog Input	<b>ANB3</b> — Analog input to ADC B, channel 3  <b>Port C GPIO</b> — This GPIO pin can be individually programmed as an input or output pin.  After reset, the default state is ANB3.

Return to [Table 2-2](#)

## Part 3 OCCS

### 3.1 Overview

This module provides the 2X system clock frequency to the System Integration Module (SIM), which uses it to generate the various chip clocks. This module also produces the OSC\_CLK signals plus the ADC clock and high-speed peripheral clock.

The on-chip clock synthesis module allows product design using an internal relaxation oscillator to run 56F8000 family parts at user-selectable frequencies up to 32MHz.

### 3.2 Features

The On-Chip Clock Synthesis (OCCS) module interfaces to the oscillator and PLL. The OCCS module features:

- Internal relaxation oscillator
- Ability to power down the internal relaxation oscillator
- Ability to put the internal relaxation oscillator into a standby mode
- 3-bit postscaler provides control for the PLL output
- Ability to power down the internal PLL
- Provides 2X master clock frequency and OSC\_CLK signals
- Provides 3X fast peripheral clock to PWM and Timer
- Safety shutdown feature is available in the event that the PLL reference clock disappears
- Can be driven from an external clock source

The clock generation module provides the programming interface for both the PLL and internal relaxation oscillator.

### 3.3 Operating Modes

In 56F8000 family parts, either an internal oscillator or an external frequency source can be used to provide a reference clock (SYS\_CLK2) to the SIM.

The 2X system clock source output from the OCCS can be described by one of the following equations:

$$2X \text{ system frequency} = \text{oscillator frequency}$$

$$2X \text{ system frequency} = (\text{oscillator frequency} \times 8) / (\text{postscaler})$$

where:

$$\text{postscaler} = 1, 2, 4, 8, 16, \text{ or } 32 \text{ PLL output divider}$$

The SIM is responsible for further dividing these frequencies by two, which will insure a 50% duty cycle in the system clock output.

The 56F8000 family parts' on-chip clock synthesis module has the following registers:

- Control Register (OCCS\_CR)
- Divide-by Register (OCCS\_DB)
- Status Register (OCCS\_SR)
- Shutdown Register (OCCS\_SHUTDOWN)
- Oscillator Control Register (OCCS\_OCTRL)

For more information on these registers, please refer to the **56F8000 Peripheral Reference Manual**.

### 3.3.1 External Clock Source

The recommended method of connecting an external clock is illustrated in **Figure 3-1**. The external clock source is connected to GPIOB6 / RXD.

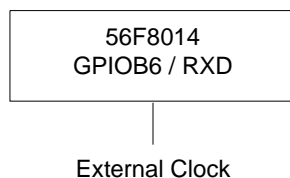

**Figure 3-1 Connecting an External Clock Signal using GPIOB6 / RXD**

### 3.4 Block Diagram

Figure 3-2 provides a block diagram which shows how the 56F8014 creates its internal clock, using the relaxation oscillator as an 8MHz clock reference for the PLL.

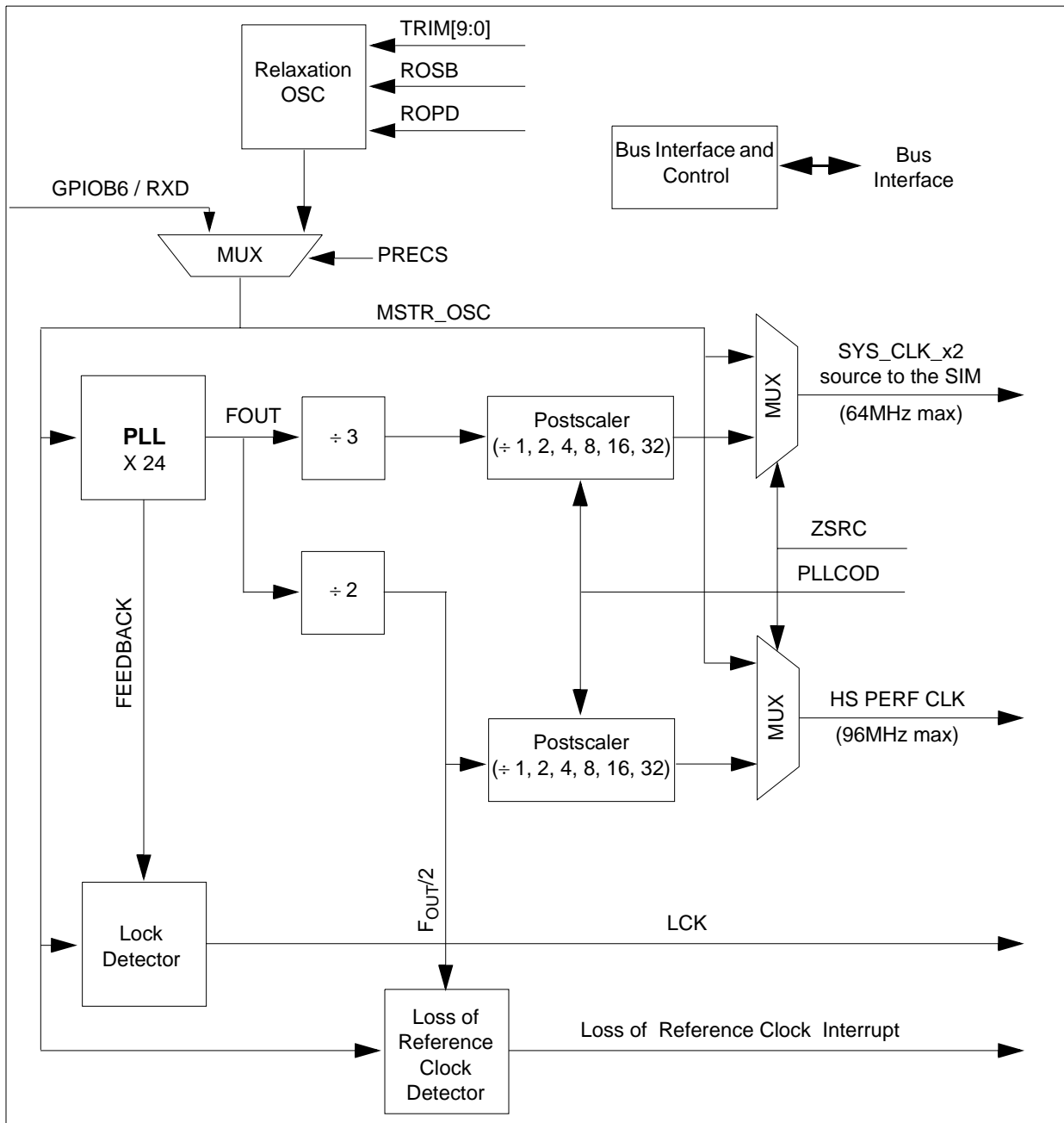

Figure 3-2 OCCS Block Diagram with Relaxation Oscillator

## 3.5 Pin Descriptions

### 3.5.1 External Reference (GPIOB6 / RXD)

The relaxation oscillator is included on chip and the reset mode is to use this as the clock source for the chip. The user then has the option of switching to an external clock reference if desired.

## Part 4 Memory Map

### 4.1 Introduction

The 56F8014 device is a 16-bit motor-control chip based on the 56800E core. It uses a Harvard-style architecture with two independent memory spaces for Data and Program. On-chip RAM is used in both spaces and Flash memory is used only in Program space.

This section provides memory maps for:

- Program Address Space, including the Interrupt Vector Table
- Data Address Space, including the EOnCE Memory and Peripheral Memory Maps

On-chip memory sizes for the device are summarized in [Table 4-1](#). Flash memories' restrictions are identified in the "Use Restrictions" column of [Table 4-1](#).

**Table 4-1 Chip Memory Configurations**

On-Chip Memory	56F8014	Use Restrictions
Program Flash (PFLASH)	8k x 16	Erase / Program via Flash interface unit and word writes to CDBW
Unified RAM (ram)	2k x 16	Usable by both the Program and Data memory spaces

### 4.2 Interrupt Vector Table

[Table 4-2](#) provides the 56F8014's reset and interrupt priority structure, including on-chip peripherals. The table is organized with higher-priority vectors at the top and lower-priority interrupts lower in the table. As indicated, the priority of an interrupt can be assigned to different levels, allowing some control over interrupt priorities. All level 3 interrupts will be serviced before level 2, and so on. For a selected priority level, the lowest vector number has the highest priority.

The location of the vector table is determined by the Vector Base Address (VBA). Please see [Section 5.6.11](#) for the reset value of the VBA.

By default, VBA = 0, and the reset address and COP reset address will correspond to vector 0 and 1 of the interrupt vector table. In these instances, the first two locations in the vector table must contain branch or JMP instructions. All other entries must contain JSR instructions.

**Table 4-2 Interrupt Vector Table Contents<sup>1</sup>**

Peripheral	Vector Number	Priority Level	Vector Base Address +	Interrupt Function
core			P:\$00	Reserved for Reset Overlay <sup>2</sup>
core			P:\$02	Reserved for COP Reset Overlay
core	2	3	P:\$04	Illegal Instruction
core	3	3	P:\$06	SW Interrupt 3
core	4	3	P:\$08	HW Stack Overflow
core	5	3	P:\$0A	Misaligned Long Word Access
core	6	1-3	P:\$0C	EOnCE Step Counter
core	7	1-3	P:\$0E	EOnCE Breakpoint Unit 0
core	8	1-3	P:\$10	EOnCE Trace Buffer
core	9	1-3	P:\$12	EOnCE Transmit Register Empty
core	10	1-3	P:\$14	EOnCE Receive Register Full
core	11	2	P:\$16	SW Interrupt 2
core	12	1	P:\$18	SW Interrupt 1
core	13	0	P:\$1A	SW Interrupt 0
	14			Reserved
	15			Reserved
PS	16	0-2	P:\$20	Power Sense
OCCS	17	0-2	P:\$22	PLL Lock, Loss of Clock Reference Interrupt
FM	18	0-2	P:\$24	FM Access Error Interrupt
FM	19	0-2	P:\$26	FM Command Complete
FM	20	0-2	P:\$28	FM Command, data and address Buffers Empty
	21			Reserved
GPIOD	22	0-2	P:\$2C	GPIOD
GPIOC	23	0-2	P:\$2E	GPIOC
GPIOB	24	0-2	P:\$30	GPIOB
GPIOA	25	0-2	P:\$32	GPIOA
SPI	26	0-2	P:\$34	SPI Receiver Full / Error
SPI	27	0-2	P:\$36	SPI Transmitter Empty
SCI	28	0-2	P:\$38	SCI Transmitter Empty
SCI	29	0-2	P:\$3A	SCI Transmitter Idle
SCI	30	0-2	P:\$3C	SCI Reserved
SCI	31	0-2	P:\$3E	SCI Receiver Error
SCI	32	0-2	P:\$40	SCI Receiver Full
	33, 34			Reserved
I <sup>2</sup> C	35	0-2	P:\$46	I <sup>2</sup> C
Timer	36	0-2	P:\$48	Timer Channel 0
Timer	37	0-2	P:\$4A	Timer Channel 1

(Continues next page)

**Table 4-2 Interrupt Vector Table Contents<sup>1</sup> (Continued)**

Peripheral	Vector Number	Priority Level	Vector Base Address +	Interrupt Function
Timer	38	0-2	P:\$4C	Timer Channel 2
Timer	39	0-2	P:\$4E	Timer Channel 3
ADC	40	0-2	P:\$50	ADCA Conversion Complete
ADC	41	0-2	P:\$52	ADCB Conversion Complete
ADC	42	0-2	P:\$54	ADC Zero Crossing or Limit Error
PWM	43	0-2	P:\$56	Reload PWM
PWM	44	0-2	P:\$58	PWM Fault
SWILP	45	-1	P:\$5A	SW Interrupt Low Priority

1. Two words are allocated for each entry in the vector table. This does not allow the full address range to be referenced from the vector table, providing only 19 bits of address.
2. If the VBA is set to \$0000, the first two locations of the vector table will overlay the chip reset addresses.

## 4.3 Program Map

The Program Memory map is shown in [Table 4-3](#).

**Table 4-3 Program Memory Map<sup>1</sup>**

Begin/End Address	Memory Allocation
P: \$FF FFFF P: \$00 8800	RESERVED
P: \$00 87FF P: \$00 8000	On-Chip RAM <sup>2</sup> 4KB
P: \$00 7FFF P: \$00 2000	RESERVED
P: \$00 1FFF P: \$00 0000	Internal Program Flash 16KB Cop Reset Address = \$00 0002 Boot Location = \$00 0000

1. All addresses are 16-bit Word addresses.
2. This RAM is shared with Data space starting at address X: \$00 0000; see [Figure 4-1](#).

## 4.4 Data Map

**Table 4-4 Data Memory Map<sup>1</sup>**

Begin/End Address	Memory Allocation
X:\$FF FFFF X:\$FF FF00	EOnCE 256 locations allocated
X:\$FF FEFF X:\$01 0000	RESERVED
X:\$00 FFFF X:\$00 F000	On-Chip Peripherals 4096 locations allocated
X:\$00 EFFF X:\$00 8800	RESERVED
X:\$00 EFFF X:\$00 0800	Reserved
X:\$00 7FFF X:\$00 0040	RESERVED
X:\$00 07FF X:\$00 0000	On-Chip Data RAM <sup>2</sup> 4KB

1. All addresses are 16-bit Word addresses.

2. This RAM is shared with Program space starting at P: \$00 8000; see [Figure 4-1](#).

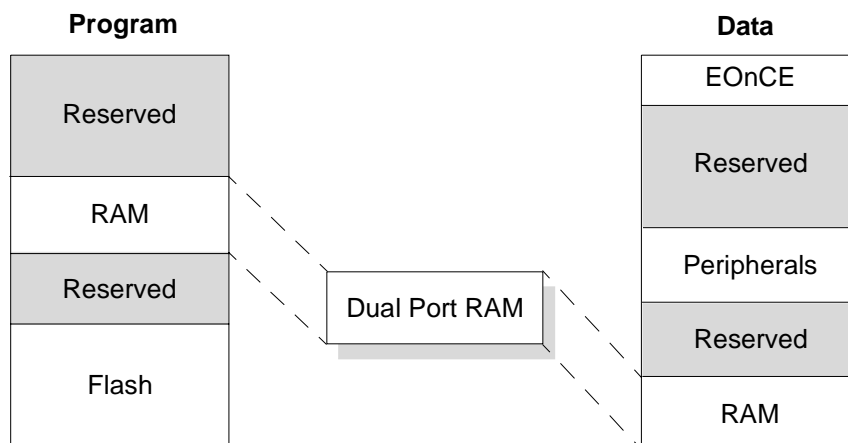

**Figure 4-1 Dual Port RAM**

## 4.5 EOnCE Memory Map

Figure 4-5 lists all EOnCE registers necessary to access or control the EOnCE.

**Table 4-5 EOnCE Memory Map**

Address	Register Acronym	Register Name
X:\$FF FFFF	OTX1 / ORX1	Transmit Register Upper Word Receive Register Upper Word
X:\$FF FFFE	OTX / ORX (32 bits)	Transmit Register Receive Register
X:\$FF FFFD	OTXRCSR	Transmit and Receive Status and Control Register
X:\$FF FFFC	OCLSR	Core Lock / Unlock Status Register
X:\$FF FFFB - X:\$FF FFA1		Reserved
X:\$FF FFA0	OCR	Control Register
X:\$FF FF9F		Instruction Step Counter
X:\$FF FF9E	OSCNTR (24 bits)	Instruction Step Counter
X:\$FF FF9D	OSR	Status Register
X:\$FF FF9C	OBASE	Peripheral Base Address Register
X:\$FF FF9B	OTBCR	Trace Buffer Control Register
X:\$FF FF9A	OTBPR	Trace Buffer Pointer Register
X:\$FF FF99		Trace Buffer Register Stages
X:\$FF FF98	OTB (21 - 24 bits/stage)	Trace Buffer Register Stages
X:\$FF FF97		Breakpoint Unit Control Register
X:\$FF FF96	OBCR (24 bits)	Breakpoint Unit Control Register
X:\$FF FF95		Breakpoint Unit Address Register 1
X:\$FF FF94	OBAR1 (24 bits)	Breakpoint Unit Address Register 1
X:\$FF FF93		Breakpoint Unit Address Register 2
X:\$FF FF92	OBAR2 (32 bits)	Breakpoint Unit Address Register 2
X:\$FF FF91		Breakpoint Unit Mask Register 2
X:\$FF FF90	OBMSK (32 bits)	Breakpoint Unit Mask Register 2
X:\$FF FF8F		Reserved
X:\$FF FF8E	OBCNTR	EOnCE Breakpoint Unit Counter
X:\$FF FF8D		Reserved
X:\$FF FF8C		Reserved
X:\$FF FF8B		Reserved
X:\$FF FF8A	OESCR	External Signal Control Register
X:\$FF FF89 - X:\$FF FF00		Reserved

## 4.6 Peripheral Memory Mapped Registers

On-chip peripheral registers are part of the data memory map on the 56800E series. These locations may be accessed with the same addressing modes used for ordinary Data memory, except all peripheral registers should be read/written using word accesses only.

**Table 4-6** summarizes base addresses for the set of peripherals on the 56F8014 device. Peripherals are listed in order of the base address.

The following tables list all of the peripheral registers required to control or access the peripherals.

**Table 4-6 Data Memory Peripheral Base Address Map Summary**

Peripheral	Prefix	Base Address	Table Number
Timer	TMR $n$	X:\$00 F000	<a href="#">4-7</a>
PWM	PWM	X:\$00 F040	<a href="#">4-8</a>
ITCN	ITCN	X:\$00 F060	<a href="#">4-9</a>
ADC	ADC	X:\$00 F080	<a href="#">4-10</a>
SCI	SCI	X:\$00 F0B0	<a href="#">4-11</a>
SPI	SPI	X:\$00 F0C0	<a href="#">4-12</a>
I <sup>2</sup> C	I2C	X:\$00 F0D0	<a href="#">4-13</a>
COP	COP	X:\$00 F0E0	<a href="#">4-14</a>
CLK, PLL, OSC, TEST	OCCS	X:\$00 F0F0	<a href="#">4-15</a>
GPIO Port A	GPIOA	X:\$00 F100	<a href="#">4-16</a>
GPIO Port B	GPIOB	X:\$00 F110	<a href="#">4-17</a>
GPIO Port C	GPIOC	X:\$00 F120	<a href="#">4-18</a>
GPIO Port D	GPIOD	X:\$00 F130	<a href="#">4-19</a>
SIM	SIM	X:\$00 F140	<a href="#">4-20</a>
Power Supervisor	PS	X:\$00 F160	<a href="#">4-21</a>
FM	FM	X:\$00 F400	<a href="#">4-22</a>

**Table 4-7 Quad Timer Registers Address Map  
(TMR\_BASE = \$00 F000)**

Register Acronym	Address Offset	Register Description
TMR0_COMP1	\$0	Compare Register 1
TMR0_COMP2	\$1	Compare Register 2
TMR0_CAPT	\$2	Capture Register
TMR0_LOAD	\$3	Load Register
TMR0_HOLD	\$4	Hold Register
TMR0_CNTR	\$5	Counter Register
TMR0_CTRL	\$6	Control Register
TMR0_SCTRL	\$7	Status and Control Register
TMR0_CMPLD1	\$8	Comparator Load Register 1

**Table 4-7 Quad Timer Registers Address Map  
(TMR\_BASE = \$00 F000) (Continued)**

Register Acronym	Address Offset	Register Description
TMR0_CMPLD2	\$9	Comparator Load Register 2
TMR0_CSCTRL	\$A	Comparator Status and Control Register
		Reserved
TMR1_COMP1	\$10	Compare Register 1
TMR1_COMP2	\$11	Compare Register 2
TMR1_CAPT	\$12	Capture Register
TMR1_LOAD	\$13	Load Register
TMR1_HOLD	\$14	Hold Register
TMR1_CNTR	\$15	Counter Register
TMR1_CTRL	\$16	Control Register
TMR1_SCTRL	\$17	Status and Control Register
TMR1_CMPLD1	\$18	Comparator Load Register 1
TMR1_CMPLD2	\$19	Comparator Load Register 2
TMR1_CSCTRL	\$1A	Comparator Status and Control Register
		Reserved
TMR2_COMP1	\$20	Compare Register 1
TMR2_COMP2	\$21	Compare Register 2
TMR2_CAPT	\$22	Capture Register
TMR2_LOAD	\$23	Load Register
TMR2_HOLD	\$24	Hold Register
TMR2_CNTR	\$25	Counter Register
TMR2_CTRL	\$26	Control Register
TMR2_SCTRL	\$27	Status and Control Register
TMR2_CMPLD1	\$28	Comparator Load Register 1
TMR2_CMPLD2	\$29	Comparator Load Register 2
TMR2_CSCTRL	\$2A	Comparator Status and Control Register
		Reserved
TMR3_COMP1	\$30	Compare Register 1
TMR3_COMP2	\$31	Compare Register 2
TMR3_CAPT	\$32	Capture Register
TMR3_LOAD	\$33	Load Register
TMR3_HOLD	\$34	Hold Register
TMR3_CNTR	\$35	Counter Register
TMR3_CTRL	\$36	Control Register
TMR3_SCTRL	\$37	Status and Control Register
TMR3_CMPLD1	\$38	Comparator Load Register 1
TMR3_CMPLD2	\$39	Comparator Load Register 2
TMR3_CSCTRL	\$3A	Comparator Status and Control Register

**Table 4-8 Pulse Width Modulator Registers Address Map  
(PWM\_BASE = \$00 F040)**

Register Acronym	Address Offset	Register Description
PWM_CTRL	\$0	Control Register
PWM_FCTRL	\$1	Fault Control Register
PWM_FLTACK	\$2	Fault Status Acknowledge Register
PWM_OUT	\$3	Output Control Register
PWM_CNTR	\$4	Counter Register
PWM_CMOD	\$5	Counter Modulo Register
PWM_VAL0	\$6	Value Register 0
PWM_VAL1	\$7	Value Register 1
PWM_VAL2	\$8	Value Register 2
PWM_VAL3	\$9	Value Register 3
PWM_VAL4	\$A	Value Register 4
PWM_VAL5	\$B	Value Register 5
PWM_DTIM0	\$C	Dead Time Register 0
PWM_DTIM1	\$D	Dead Time Register 1
PWM_DMAP1	\$E	Disable Mapping Register 1
PWM_DMAP2	\$F	Disable Mapping Register 2
PWM_CNFG	\$10	Configure Register
PWM_CCTRL	\$11	Channel Control Register
PWM_PORT	\$12	Port Register
PWM_ICCTRL	\$13	Internal Correction Control Register
PWM_SCTRL	\$14	Source Control Register

**Table 4-9 Interrupt Control Registers Address Map  
(ITCN\_BASE = \$00 F060)**

Register Acronym	Address Offset	Register Description
ITCN_IPR0	\$0	Interrupt Priority Register 0
ITCN_IPR1	\$1	Interrupt Priority Register 1
ITCN_IPR2	\$2	Interrupt Priority Register 2
ITCN_IPR3	\$3	Interrupt Priority Register 3
ITCN_IPR4	\$4	Interrupt Priority Register 4
ITCN_VBA	\$5	Vector Base Address Register
ITCN_FIM0	\$6	Fast Interrupt Match 0 Register
ITCN_FIVAL0	\$7	Fast Interrupt Vector Address Low 0 Register
ITCN_FIVAH0	\$8	Fast Interrupt Vector Address High 0 Register
ITCN_FIM1	\$9	Fast Interrupt Match 1 Register

**Table 4-9 Interrupt Control Registers Address Map  
(ITCN\_BASE = \$00 F060) (Continued)**

Register Acronym	Address Offset	Register Description
ITCN_FIVAL1	\$A	Fast Interrupt Vector Address Low 1 Register
ITCN_FIVAH1	\$B	Fast Interrupt Vector Address High 1 Register
ITCN_IRQP 0	\$C	IRQ Pending Register 0
ITCN_IRQP 1	\$D	IRQ Pending Register 1
ITCN_IRQP 2	\$E	IRQ Pending Register 2
		Reserved
ITCN_ICTRL	\$12	Interrupt Control Register
		Reserved

**Table 4-10 Analog-to-Digital Converter Registers Address Map  
(ADC\_BASE = \$00 F080)**

Register Acronym	Address Offset	Register Description
ADC_CTRL1	\$0	Control Register 1
ADC_CTRL2	\$1	Control Register 2
ADC_ZXCTRL	\$2	Zero Crossing Control Register
ADC_CLIST 1	\$3	Channel List Register 1
ADC_CLIST 2	\$4	Channel List Register 2
ADC_SDIS	\$5	Sample Disable Register
ADC_STAT	\$6	Status Register
ADC_LIMSTAT	\$7	Limit Status Register
ADC_ZXSTAT	\$8	Zero Crossing Status Register
ADC_RSLT0	\$9	Result Register 0
ADC_RSLT1	\$A	Result Register 1
ADC_RSLT2	\$B	Result Register 2
ADC_RSLT3	\$C	Result Register 3
ADC_RSLT4	\$D	Result Register 4
ADC_RSLT5	\$E	Result Register 5
ADC_RSLT6	\$F	Result Register 6
ADC_RSLT7	\$10	Result Register 7
ADC_LOLIM0	\$11	Low Limit Register 0
ADC_LOLIM1	\$12	Low Limit Register 1
ADC_LOLIM2	\$13	Low Limit Register 2
ADC_LOLIM3	\$14	Low Limit Register 3
ADC_LOLIM4	\$15	Low Limit Register 4
ADC_LOLIM5	\$16	Low Limit Register 5
ADC_LOLIM6	\$17	Low Limit Register 6

**Table 4-10 Analog-to-Digital Converter Registers Address Map  
(ADC\_BASE = \$00 F080) (Continued)**

Register Acronym	Address Offset	Register Description
ADC_LOLIM7	\$18	Low Limit Register 7
ADC_HILIM0	\$19	High Limit Register 0
ADC_HILIM1	\$1A	High Limit Register 1
ADC_HILIM2	\$1B	High Limit Register 2
ADC_HILIM3	\$1C	High Limit Register 3
ADC_HILIM4	\$1D	High Limit Register 4
ADC_HILIM5	\$1E	High Limit Register 5
ADC_HILIM6	\$1F	High Limit Register 6
ADC_HILIM7	\$20	High Limit Register 7
ADC_OFFST0	\$21	Offset Register 0
ADC_OFFST1	\$22	Offset Register 1
ADC_OFFST2	\$23	Offset Register 2
ADC_OFFST3	\$24	Offset Register 3
ADC_OFFST4	\$25	Offset Register 4
ADC_OFFST5	\$26	Offset Register 5
ADC_OFFST6	\$27	Offset Register 6
ADC_OFFST7	\$28	Offset Register 7
ADC_PWR	\$29	Power Control Register
ADC_VREF	\$2A	Voltage Reference Register
		Reserved

**Table 4-11 Serial Communication Interface Registers Address Map  
(SCI\_BASE = \$00 F0B0)**

Register Acronym	Address Offset	Register Description
SCI_RATE	\$0	Baud Rate Register
SCI_CTRL1	\$1	Control Register 1
SCI_CTRL2	\$2	Control Register 2
SCI_STAT	\$3	Status Register
SCI_DATA	\$4	Data Register

**Table 4-12 Serial Peripheral Interface Registers Address Map  
(SPI\_BASE = \$00 F0C0)**

Register Acronym	Address Offset	Register Description
SPI_SCTRL	\$0	Status and Control Register
SPI_DSCTRL	\$1	Data Size and Control Register
SPI_DRCV	\$2	Data Receive Register
SPI_DXMIT	\$3	Data Transmit Register

**Table 4-13 I<sup>2</sup>C Registers Address Map  
(I2C\_BASE = \$00 F0D0)**

Register Acronym	Address Offset	Register Description
I2C_ADDR	\$0	Address Register
I2C_FDIV	\$1	Frequency Divider Register
I2C_CTRL	\$2	Control Register
I2C_STAT	\$3	Status Register
I2C_DATA	\$4	Data Register
I2C_NFILT	\$5	Noise Filter Register

**Table 4-14 Computer Operating Properly Registers Address Map  
(COP\_BASE = \$00 F0E0)**

Register Acronym	Address Offset	Register Description
COP_CTRL	\$0	Control Register
COP_TOUT	\$1	Time-Out Register
COP_CNTR	\$2	Counter Register

**Table 4-15 Clock Generation Module Registers Address Map  
(OCCS\_BASE = \$00 F0F0)**

Register Acronym	Address Offset	Register Description
OCCS_CTRL	\$0	Control Register
OCCS_DIVBY	\$1	Divide-By Register
OCCS_STAT	\$2	Status Register
		Reserved
OCCS_SHUTDN	\$4	Shutdown Register
OCCS_OCTRL	\$5	Oscillator Control Register

**Table 4-16 GPIOA Registers Address Map  
(GPIOA\_BASE = \$00 F100)**

Register Acronym	Address Offset	Register Description
GPIOA_PUPEN	\$0	Pull-up Enable Register
GPIOA_DATA	\$1	Data Register
GPIOA_DDIR	\$2	Data Direction Register
GPIOA_PEREN	\$3	Peripheral Enable Register
GPIOA_IASSRT	\$4	Interrupt Assert Register
GPIOA_IEN	\$5	Interrupt Enable Register
GPIOA_IEPOL	\$6	Interrupt Edge Polarity Register
GPIOA_IPEND	\$7	Interrupt Pending Register
GPIOA_IEDGE	\$8	Interrupt Edge-Sensitive Register
GPIOA_PPOUTM	\$9	Push-Pull Output Mode Control Register
GPIOA_RDATA	\$A	Raw Data Register
GPIOA_DRIVE	\$B	Drive Strength Control Register

**Table 4-17 GPIOB Registers Address Map  
(GPIOB\_BASE = \$00 F110)**

Register Acronym	Address Offset	Register Description
GPIOB_PUPEN	\$0	Pull-up Enable Register
GPIOB_DATA	\$1	Data Register
GPIOB_DDIR	\$2	Data Direction Register
GPIOB_PEREN	\$3	Peripheral Enable Register
GPIOB_IASSRT	\$4	Interrupt Assert Register
GPIOB_IEN	\$5	Interrupt Enable Register
GPIOB_IEPOL	\$6	Interrupt Edge Polarity Register
GPIOB_IPEND	\$7	Interrupt Pending Register
GPIOB_IEDGE	\$8	Interrupt Edge-Sensitive Register
GPIOB_PPOUTM	\$9	Push-Pull Output Mode Control Register
GPIOB_RDATA	\$A	Raw Data Register
GPIOB_DRIVE	\$B	Drive Strength Control Register

**Table 4-18 GPIOC Registers Address Map  
(GPIOC\_BASE = \$00 F120)**

Register Acronym	Address Offset	Register Description
GPIOC_PUPEN	\$0	Pull-up Enable Register
GPIOC_DATA	\$1	Data Register
GPIOC_DDIR	\$2	Data Direction Register
GPIOC_PEREN	\$3	Peripheral Enable Register
GPIOC_IASSRT	\$4	Interrupt Assert Register
GPIOC_IEN	\$5	Interrupt Enable Register
GPIOC_IEPOL	\$6	Interrupt Edge Polarity Register
GPIOC_IPEND	\$7	Interrupt Pending Register
GPIOC_IEDGE	\$8	Interrupt Edge-Sensitive Register
GPIOC_PPOUTM	\$9	Push-Pull Output Mode Control Register
GPIOC_RDATA	\$A	Raw Data Register
GPIOC_DRIVE	\$B	Drive Strength Control Register

**Table 4-19 GPIOD Registers Address Map  
(GPIOD\_BASE = \$00 F130)**

Register Acronym	Address Offset	Register Description
GPIOD_PUPEN	\$0	Pull-up Enable Register
GPIOD_DATA	\$1	Data Register
GPIOD_DDIR	\$2	Data Direction Register
GPIOD_PEREN	\$3	Peripheral Enable Register
GPIOD_IASSRT	\$4	Interrupt Assert Register
GPIOD_IEN	\$5	Interrupt Enable Register
GPIOD_IEPOL	\$6	Interrupt Edge Polarity Register
GPIOD_IPEND	\$7	Interrupt Pending Register
GPIOD_IEDGE	\$8	Interrupt Edge-Sensitive Register
GPIOD_PPOUTM	\$9	Push-Pull Output Mode Control Register
GPIOD_RDATA	\$A	Raw Data Register
GPIOD_DRIVE	\$B	Drive Strength Control Register

**Table 4-20 System Integration Module Registers Address Map  
(SIM\_BASE = \$00 F140)**

Register Acronym	Address Offset	Register Description
SIM_CTRL	\$0	Control Register
SIM_RSTAT	\$1	Reset Status Register
SIM_SWC0	\$2	Software Control Register 0
SIM_SWC1	\$3	Software Control Register 1
SIM_SWC2	\$4	Software Control Register 2
SIM_SWC3	\$5	Software Control Register 3
SIM_MSHID	\$6	Most Significant Half JTAG ID
SIM_LSHID	\$7	Least Significant Half JTAG ID
SIM_PWR	\$8	Power Control Register
		Reserved
SIM_CLKOUT	\$A	Clock Out Select Register
SIM_GPS	\$B	GPIO Peripheral Select Register
SIM_PCE	\$C	Peripheral Clock Enable Register
SIM_IOSAHI	\$D	I/O Short Address Location High Register
SIM_IOSALO	\$E	I/O Short Address Location Low Register

**Table 4-21 Power Supervisor Registers Address Map  
(PS\_BASE = \$00 F160)**

Register Acronym	Address Offset	Register Description
PS_CTRL	\$0	Control Register
PS_STAT	\$1	Status Register

**Table 4-22 Flash Module Registers Address Map  
(FM\_BASE = \$00 F400)**

Register Acronym	Address Offset	Register Description
FM_CLKDIV	\$0	Clock Divider Register
FM_CNFG	\$1	Configuration Register
	\$2	Reserved
FM_SECHI	\$3	Security High Half Register
FM_SECLO	\$4	Security Low Half Register
	\$5 - \$9	Reserved
FM_PROT	\$10	Protection Register
	\$11 - \$12	Reserved
FM_USTAT	\$13	User Status Register
FM_CMD	\$14	Command Register
	\$15	Reserved
	\$16	Reserved
	\$17	Reserved
FM_DATA	\$18	Data Buffer Register
	\$19	Reserved
	\$1A	Reserved
FM_OPT1	\$1B	Optional Data 1 Register
		Reserved
FM_TTSIG	\$1D	Test Array Signature Register

## Part 5 Interrupt Controller (ITCN)

### 5.1 Introduction

The Interrupt Controller (ITCN) module is used to arbitrate between various interrupt requests (IRQs), to signal to the 56800E core when an interrupt of sufficient priority exists, and to what address to jump in order to service this interrupt.

### 5.2 Features

The ITCN module design includes these distinctive features:

- Programmable priority levels for each IRQ
- Two programmable Fast Interrupts
- Notification to SIM module to restart clocks out of Wait and Stop modes
- Ability to drive initial address on the address bus after reset

For further information, see [Table 4-2](#), Interrupt Vector Table Contents.

### 5.3 Functional Description

The Interrupt Controller is a slave on the IPBus. It contains registers that allow each of the 46 interrupt sources to be set to one of four priority levels (excluding certain interrupts that are of fixed priority). Next, all of the interrupt requests of a given level are priority encoded to determine the lowest numerical value of the active interrupt requests for that level. Within a given priority level, number 0 is the highest priority and number 45 is the lowest.

#### 5.3.1 Normal Interrupt Handling

Once the INTC has determined that an interrupt is to be serviced and which interrupt has the highest priority, an interrupt vector address is generated. Normal interrupt handling concatenates the Vector Base Address (VBA) and the vector number to determine the vector address, generating an offset into the vector table for each interrupt.

#### 5.3.2 Interrupt Nesting

Interrupt exceptions may be nested to allow an IRQ of higher priority than the current exception to be serviced. The following table defines the nesting requirements for each priority level.

**Table 5-1 Interrupt Mask Bit Definition**

SR[9]	SR[8]	Exceptions Permitted	Exceptions Masked
0	0	Priorities 0, 1, 2, 3	None
0	1	Priorities 1, 2, 3	Priority 0
1	0	Priorities 2, 3	Priorities 0, 1
1	1	Priority 3	Priorities 0, 1, 2

### 5.3.3 Fast Interrupt Handling

Fast interrupts are described in the **DSP56800E Reference Manual**. The interrupt controller recognizes Fast Interrupts before the core does.

A Fast Interrupt is defined (to the ITCN) by:

1. Setting the priority of the interrupt as level 2, with the appropriate field in the IPR registers
2. Setting the FIM $n$  register to the appropriate vector number
3. Setting the FIVAL $n$  and FIVAH $n$  registers with the address of the code for the Fast Interrupt

When an interrupt occurs, its vector number is compared with the FIM0 and FIM1 register values. If a match occurs, and it is a level 2 interrupt, the ITCN handles it as a Fast Interrupt. The ITCN takes the vector address from the appropriate FIVAL $n$  and FIVAH $n$  registers, instead of generating an address that is an offset from the VBA.

The core then fetches the instruction from the indicated vector address and if it is not a JSR, the core starts its Fast Interrupt handling.

## 5.4 Block Diagram

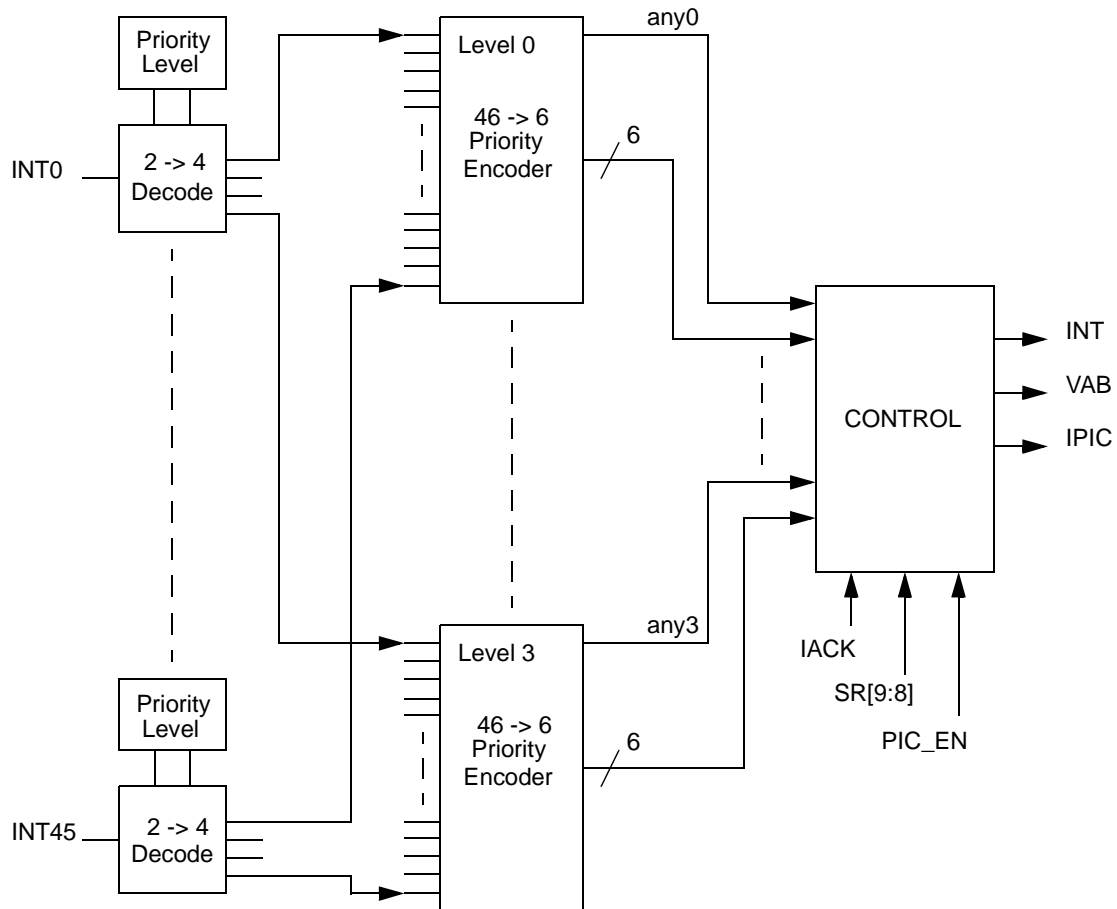

Figure 5-1 Interrupt Controller Block Diagram

## 5.5 Operating Modes

The ITCN module design contains two major modes of operation:

- **Functional Mode**  
The ITCN is in this mode by default.
- **Wait and Stop Modes**  
During Wait and Stop modes, the system clocks and the 56800E core are turned off. The ITCN will signal a pending IRQ to the System Integration Module (SIM) to restart the clocks and service the IRQ. An IRQ can only wake up the core if the IRQ is enabled prior to entering the Wait or Stop mode.

## 5.6 Register Descriptions

A register address is the sum of a base address and an address offset. The base address is defined at the system level and the address offset is defined at the module level. The ITCN module has 16 registers.

**Table 5-2 ITCN Register Summary  
(ITCN\_BASE = \$00 F060)**

Register Acronym	Base Address +	Register Name	Section Location
IPR0	\$0	Interrupt Priority Register 0	<a href="#">5.6.1</a>
IPR1	\$1	Interrupt Priority Register 1	<a href="#">5.6.2</a>
IPR2	\$2	Interrupt Priority Register 2	<a href="#">5.6.3</a>
IPR3	\$3	Interrupt Priority Register 3	<a href="#">5.6.4</a>
IPR4	\$4	Interrupt Priority Register 4	<a href="#">5.6.5</a>
VBA	\$5	Vector Base Address Register	<a href="#">5.6.6</a>
FIM0	\$6	Fast Interrupt Match 0 Register	<a href="#">5.6.7</a>
FIVAL0	\$7	Fast Interrupt 0 Vector Address Low Register	<a href="#">5.6.8</a>
FIVAH0	\$8	Fast Interrupt 0 Vector Address High Register	<a href="#">5.6.9</a>
FIM1	\$9	Fast Interrupt Match 1 Register	<a href="#">5.6.10</a>
FIVAL1	\$A	Fast Interrupt 1 Vector Address Low Register	<a href="#">5.6.11</a>
FIVAH1	\$B	Fast Interrupt 1 Vector Address High Register	<a href="#">5.6.12</a>
IRQP0	\$C	IRQ Pending Register 0	<a href="#">5.6.13</a>
IRQP1	\$D	IRQ Pending Register 1	<a href="#">5.6.14</a>
IRQP2	\$E	IRQ Pending Register 2	<a href="#">5.6.15</a>
		Reserved	
ICTRL	\$12	Interrupt Control Register	<a href="#">5.6.16</a>
		Reserved	

Add. Offset	Register Name		15	14	13	12	11	10	9	8	7	6	5	4	3	2	1	0	
\$0	IPR0	R	LVI IPL		0	0	0	0	RX_REG IPL		TX_REG IPL		TRBUF IPL		BKPT_U IPL		STPCNT IPL		
		W																	
\$1	IPR1	R	GPIOB IPL		GPIOC IPL		GPIOD IPL		0	0	FM_CBE IPL		FM_CC IPL		FM_ERR IPL		PLL IPL		
		W																	
\$2	IPR2	R	SCI_RCV IPL		SCI_RERR IPL		0	0	SCI_TIDL IPL		SCI_XMIT IPL		SPI_XMIT IPL		SPI_RCV IPL		GPIOA IPL		
		W																	
\$3	IPR3	R	ADCA_CC IPL		TMR_3 IPL		TMR_2 IPL		TMR_1 IPL		TMR_0 IPL		I2C_ADDR IPL		0	0	0	0	
		W																	
\$4	IPR4	R	0	0	0	0	0	0	0	0	PWM_F IPL		PWM_RL IPL		ADC_ZC_LE IPL		ADCB_CC IPL		
		W																	
\$5	VBA	R	0	0	VECTOR_BASE_ADDRESS														
		W																	
\$6	FIM0	R	0	0	0	0	0	0	0	0	0	0	0	FAST INTERRUPT 0					
		W																	
\$7	FIVAL0	R	FAST INTERRUPT 0 VECTOR ADDRESS LOW																
		W																	
\$8	FIVAH0	R	0	0	0	0	0	0	0	0	0	0	0	0	FAST INTERRUPT 0 VECTOR ADDRESS HIGH				
		W																	
\$9	FIM1	R	0	0	0	0	0	0	0	0	0	0	FAST INTERRUPT 1						
		W																	
\$A	FIVAL1	R	FAST INTERRUPT 1 VECTOR ADDRESS LOW																
		W																	
\$B	FIVAH1	R	0	0	0	0	0	0	0	0	0	0	0	0	FAST INTERRUPT 1 VECTOR ADDRESS HIGH				
		W																	
\$C	IRQP0	R	PENDING[16:2]															1	
		W																	
\$D	IRQP1	R	PENDING[32:17]																
		W																	
\$E	IRQP2	R	1	1	1	PENDING[45:33]													
		W																	
	Reserved																		
\$12	ICTRL	R	INT	IPIC		VAB						INT_DIS		1	1	1	0	0	
		W																	
	Reserved																		

■ = Reserved

Figure 5-2 ITCN Register Map Summary

## 5.6.1 Interrupt Priority Register 0 (IPR0)

Base + \$0	15	14	13	12	11	10	9	8	7	6	5	4	3	2	1	0
Read	LVI IPL		0	0	0	0	RX_REG IPL		TX_REG IPL		TRBUF IPL		BKPT_U IPL		STPCNT IPL	
Write																
RESET	0	0	0	0	0	0	0	0	0	0	0	0	0	0	0	0

Figure 5-3 Interrupt Priority Register 0 (IPR0)

### 5.6.1.1 LVI IPL—Bits 15–14

This field is used to set the interrupt priority levels for a peripheral IRQ. This IRQ is limited to priorities 0 through 2 and is disabled by default.

- 00 = IRQ disabled (default)
- 01 = IRQ is priority level 0
- 10 = IRQ is priority level 1
- 11 = IRQ is priority level 2

### 5.6.1.2 Reserved—Bits 13–10

This bit field is reserved or not implemented. It is read as 0 and cannot be modified by writing.

### 5.6.1.3 EOnCE Receive Register Full Interrupt Priority Level (RX\_REG IPL)— Bits 9–8

This field is used to set the interrupt priority level for IRQs. This IRQ is limited to priorities 1 through 3. It is disabled by default.

- 00 = IRQ disabled (default)
- 01 = IRQ is priority level 1
- 10 = IRQ is priority level 2
- 11 = IRQ is priority level 3

### 5.6.1.4 EOnCE Transmit Register Empty Interrupt Priority Level (TX\_REG IPL)— Bits 7–6

This field is used to set the interrupt priority level for IRQs. This IRQ is limited to priorities 1 through 3. It is disabled by default.

- 00 = IRQ disabled (default)
- 01 = IRQ is priority level 1
- 10 = IRQ is priority level 2
- 11 = IRQ is priority level 3

### 5.6.1.5 EOnCE Trace Buffer Interrupt Priority Level (TRBUF IPL)— Bits 5–4

This field is used to set the interrupt priority level for IRQs. This IRQ is limited to priorities 1 through 3. It is disabled by default.

- 00 = IRQ disabled (default)
- 01 = IRQ is priority level 1
- 10 = IRQ is priority level 2
- 11 = IRQ is priority level 3

### 5.6.1.6 EOnCE Breakpoint Unit Interrupt Priority Level (BKPT\_U IPL)— Bits 3–2

This field is used to set the interrupt priority level for IRQs. This IRQ is limited to priorities 1 through 3. It is disabled by default.

- 00 = IRQ disabled (default)
- 01 = IRQ is priority level 1
- 10 = IRQ is priority level 2
- 11 = IRQ is priority level 3

### 5.6.1.7 EOnCE Step Counter Interrupt Priority Level (STPCNT IPL)— Bits 1–0

This field is used to set the interrupt priority level for IRQs. This IRQ is limited to priorities 1 through 3. It is disabled by default.

- 00 = IRQ disabled (default)
- 01 = IRQ is priority level 1
- 10 = IRQ is priority level 2
- 11 = IRQ is priority level 3

## 5.6.2 Interrupt Priority Register 1 (IPR1)

Base + \$1	15	14	13	12	11	10	9	8	7	6	5	4	3	2	1	0
Read	GPIOB IPL		GPIOC IPL		GPIOD IPL		0	0	FM_CBE IPL		FM_CC IPL		FM_ERR IPL		PLL IPL	
Write																
RESET	0	0	0	0	0	0	0	0	0	0	0	0	0	0	0	0

Figure 5-4 Interrupt Priority Register 1 (IPR1)

### 5.6.2.1 GPIOB Interrupt Priority Level (GPIOB IPL)—Bits 15–14

This field is used to set the interrupt priority level for IRQs. This IRQ is limited to priorities 0 through 2. It is disabled by default.

- 00 = IRQ disabled (default)
- 01 = IRQ is priority level 0
- 10 = IRQ is priority level 1
- 11 = IRQ is priority level 2

### 5.6.2.2 GPIOC Interrupt Priority Level (GPIOC IPL)—Bits 13–12

This field is used to set the interrupt priority level for IRQs. This IRQ is limited to priorities 0 through 2. It is disabled by default.

- 00 = IRQ disabled (default)
- 01 = IRQ is priority level 0
- 10 = IRQ is priority level 1
- 11 = IRQ is priority level 2

### 5.6.2.3 GPIOD Interrupt Priority Level (GPIOD IPL)—Bits 11–10

This field is used to set the interrupt priority level for IRQs. This IRQ is limited to priorities 0 through 2. It is disabled by default.

- 00 = IRQ disabled (default)
- 01 = IRQ is priority level 0
- 10 = IRQ is priority level 1
- 11 = IRQ is priority level 2

### 5.6.2.4 Reserved—Bits 9–8

This bit field is reserved or not implemented. It is read as 0 and cannot be modified by writing.

### 5.6.2.5 FM Command, Data, Address Buffers Empty Interrupt Priority Level (FM\_CBE IPL)—Bits 7–6

This field is used to set the interrupt priority level for IRQs. This IRQ is limited to priorities 0 through 2. It is disabled by default.

- 00 = IRQ disabled (default)
- 01 = IRQ is priority level 0
- 10 = IRQ is priority level 1
- 11 = IRQ is priority level 2

### 5.6.2.6 FM Command Complete Priority Level (FM\_CC IPL)—Bits 5–4

This field is used to set the interrupt priority level for IRQs. This IRQ is limited to priorities 0 through 2. It is disabled by default.

- 00 = IRQ disabled (default)
- 01 = IRQ is priority level 0
- 10 = IRQ is priority level 1
- 11 = IRQ is priority level 2

### 5.6.2.7 FM Error Interrupt Priority Level (FM\_ERR IPL)—Bits 3–2

This field is used to set the interrupt priority level for IRQs. This IRQ is limited to priorities 0 through 2. It is disabled by default.

- 00 = IRQ disabled (default)
- 01 = IRQ is priority level 0
- 10 = IRQ is priority level 1
- 11 = IRQ is priority level 2

### 5.6.2.8 PLL Loss of Reference or Change in Lock Status Interrupt Priority Level (PLL IPL)—Bits 1–0

This field is used to set the interrupt priority level for IRQs. This IRQ is limited to priorities 0 through 2. It is disabled by default.

- 00 = IRQ disabled (default)
- 01 = IRQ is priority level 0
- 10 = IRQ is priority level 1
- 11 = IRQ is priority level 2

## 5.6.3 Interrupt Priority Register 2 (IPR2)

Base + \$2	15	14	13	12	11	10	9	8	7	6	5	4	3	2	1	0
Read	SCI_RCV IPL		SCI_RERR IPL		0	0	SCI_TIDL IPL		SCI_XMIT IPL		SPL_XMIT IPL		SPL_RCV IPL		GPIOA IPL	
Write																
RESET	0	0	0	0	0	0	0	0	0	0	0	0	0	0	0	0

Figure 5-5 Interrupt Priority Register 2 (IPR2)

### 5.6.3.1 SCI Receiver Full Interrupt Priority Level (SCI\_RCV IPL)— Bits 15–14

This field is used to set the interrupt priority level for IRQs. This IRQ is limited to priorities 0 through 2. It is disabled by default.

- 00 = IRQ disabled (default)
- 01 = IRQ is priority level 0
- 10 = IRQ is priority level 1
- 11 = IRQ is priority level 2

### 5.6.3.2 SCI Receiver Error Interrupt Priority Level (SCI\_RERR IPL)— Bits 13–12

This field is used to set the interrupt priority level for IRQs. This IRQ is limited to priorities 0 through 2. It is disabled by default.

- 00 = IRQ disabled (default)
- 01 = IRQ is priority level 0
- 10 = IRQ is priority level 1
- 11 = IRQ is priority level 2

### 5.6.3.3 Reserved—Bits 11–10

This bit field is reserved or not implemented. It is read as 0 and cannot be modified by writing.

### 5.6.3.4 SCI Transmitter Idle Interrupt Priority Level (SCI\_TIDL IPL)— Bits 9–8

This field is used to set the interrupt priority level for IRQs. This IRQ is limited to priorities 0 through 2. It is disabled by default.

- 00 = IRQ disabled (default)
- 01 = IRQ is priority level 0
- 10 = IRQ is priority level 1
- 11 = IRQ is priority level 2

### 5.6.3.5 SCI Transmitter Empty Interrupt Priority Level (SCI\_XMIT IPL)— Bits 7–6

This field is used to set the interrupt priority level for IRQs. This IRQ is limited to priorities 0 through 2. It is disabled by default.

- 00 = IRQ disabled (default)
- 01 = IRQ is priority level 0
- 10 = IRQ is priority level 1
- 11 = IRQ is priority level 2

### 5.6.3.6 SPI Transmitter Empty Interrupt Priority Level (SPI\_XMIT IPL)— Bits 5–4

This field is used to set the interrupt priority level for IRQs. This IRQ is limited to priorities 0 through 2. It is disabled by default.

- 00 = IRQ disabled (default)
- 01 = IRQ is priority level 0
- 10 = IRQ is priority level 1
- 11 = IRQ is priority level 2

### 5.6.3.7 SPI Receiver Full Interrupt Priority Level (SPI\_RCV IPL)— Bits 3–2

This field is used to set the interrupt priority level for IRQs. This IRQ is limited to priorities 0 through 2. It is disabled by default.

- 00 = IRQ disabled (default)
- 01 = IRQ is priority level 0
- 10 = IRQ is priority level 1
- 11 = IRQ is priority level 2

### 5.6.3.8 GPIOA Interrupt Priority Level (GPIOA IPL)—Bits 1–0

This field is used to set the interrupt priority level for IRQs. This IRQ is limited to priorities 0 through 2. It is disabled by default.

- 00 = IRQ disabled (default)
- 01 = IRQ is priority level 0
- 10 = IRQ is priority level 1
- 11 = IRQ is priority level 2

## 5.6.4 Interrupt Priority Register 3 (IPR3)

Base + \$3	15	14	13	12	11	10	9	8	7	6	5	4	3	2	1	0
Read	ADCA_CC IPL		TMR_3 IPL		TMR_2 IPL		TMR_1 IPL		TMR_0 IPL		I2C_ADDR IPL		0	0	0	0
Write																
RESET	0	0	0	0	0	0	0	0	0	0	0	0	0	0	0	0

Figure 5-6 Interrupt Priority Register 3 (IPR3)

#### 5.6.4.1 ADCA Conversion Complete Interrupt Priority Level (ADCA\_CC IPL)—Bits 15–14

This field is used to set the interrupt priority level for IRQs. This IRQ is limited to priorities 0 through 2. They are disabled by default.

- 00 = IRQ disabled (default)
- 01 = IRQ is priority level 0
- 10 = IRQ is priority level 1
- 11 = IRQ is priority level 2

#### 5.6.4.2 Timer Channel 3 Interrupt Priority Level (TMR\_3 IPL)—Bits 13–12

This field is used to set the interrupt priority level for IRQs. This IRQ is limited to priorities 0 through 2. They are disabled by default.

- 00 = IRQ disabled (default)
- 01 = IRQ is priority level 0
- 10 = IRQ is priority level 1
- 11 = IRQ is priority level 2

#### 5.6.4.3 Timer Channel 2 Interrupt Priority Level (TMR\_2 IPL)—Bits 11–10

This field is used to set the interrupt priority level for IRQs. This IRQ is limited to priorities 0 through 2. They are disabled by default.

- 00 = IRQ disabled (default)
- 01 = IRQ is priority level 0
- 10 = IRQ is priority level 1
- 11 = IRQ is priority level 2

#### 5.6.4.4 Timer Channel 1 Interrupt Priority Level (TMR\_1 IPL)—Bits 9–8

This field is used to set the interrupt priority level for IRQs. This IRQ is limited to priorities 0 through 2. They are disabled by default.

- 00 = IRQ disabled (default)
- 01 = IRQ is priority level 0
- 10 = IRQ is priority level 1
- 11 = IRQ is priority level 2

#### 5.6.4.5 Timer Channel 0 Interrupt Priority Level (TMR\_0 IPL)—Bits 7–6

This field is used to set the interrupt priority level for IRQs. This IRQ is limited to priorities 0 through 2. They are disabled by default.

- 00 = IRQ disabled (default)
- 01 = IRQ is priority level 0
- 10 = IRQ is priority level 1
- 11 = IRQ is priority level 2

#### 5.6.4.6 I<sup>2</sup>C Address Detect Interrupt Priority Level (I2C\_ADDR IPL)—Bits 5–4

This field is used to set the interrupt priority level for IRQs. This IRQ is limited to priorities 0 through 2. They are disabled by default.

- 00 = IRQ disabled (default)
- 01 = IRQ is priority level 0
- 10 = IRQ is priority level 1
- 11 = IRQ is priority level 2

#### 5.6.4.7 Reserved—Bits 3–0

This bit field is reserved or not implemented. It is read as 0 and cannot be modified by writing.

### 5.6.5 Interrupt Priority Register 4 (IPR4)

Base + \$4	15	14	13	12	11	10	9	8	7	6	5	4	3	2	1	0
Read	0	0	0	0	0	0	0	0	PWM_F IPL		PWM_RL IPL		ADC_ZC_LE IPL		ADCB_CC IPL	
Write																
RESET	0	0	0	0	0	0	0	0	0	0	0	0	0	0	0	0

Figure 5-7 Interrupt Priority Register 4 (IPR4)

#### 5.6.5.1 Reserved—Bits 15–8

This bit field is reserved or not implemented. It is read as 0 and cannot be modified by writing.

#### 5.6.5.2 PWM Fault Interrupt Priority Level (PWM\_F IPL)—Bits 7–6

This field is used to set the interrupt priority level for IRQs. This IRQ is limited to priorities 0 through 2. They are disabled by default.

- 00 = IRQ disabled (default)
- 01 = IRQ is priority level 0
- 10 = IRQ is priority level 1
- 11 = IRQ is priority level 2

#### 5.6.5.3 Reload PWM Interrupt Priority Level (PWM\_RL IPL)—Bits 5–4

This field is used to set the interrupt priority level for IRQs. This IRQ is limited to priorities 0 through 2. They are disabled by default.

- 00 = IRQ disabled (default)
- 01 = IRQ is priority level 0
- 10 = IRQ is priority level 1
- 11 = IRQ is priority level 2

#### 5.6.5.4 ADC Zero Crossing or Limit Error Interrupt Priority Level (ADC\_ZC\_LE IPL)— Bits 3–2

This field is used to set the interrupt priority level for IRQs. This IRQ is limited to priorities 0 through 2. They are disabled by default.

- 00 = IRQ disabled (default)
- 01 = IRQ is priority level 0
- 10 = IRQ is priority level 1
- 11 = IRQ is priority level 2

#### 5.6.5.5 ADCB Conversion Complete Interrupt Priority Level (ADCB\_CC IPL)—Bits 1–0

This field is used to set the interrupt priority level for IRQs. This IRQ is limited to priorities 0 through 2. They are disabled by default.

- 00 = IRQ disabled (default)
- 01 = IRQ is priority level 0
- 10 = IRQ is priority level 1
- 11 = IRQ is priority level 2

### 5.6.6 Vector Base Address Register (VBA)

Base + \$5	15	14	13	12	11	10	9	8	7	6	5	4	3	2	1	0
Read	0	0	VECTOR_BASE_ADDRESS													
Write																
RESET	0	0	0	0	0	0	0	0	0	0	0	0	0	0	0	0

Figure 5-8 Vector Base Address Register (VBA)

#### 5.6.6.1 Reserved—Bits15—14

This bit field is reserved or not implemented. It is read as 0 and cannot be modified by writing.

#### 5.6.6.2 Vector Address Bus (VAB)—Bits 13—0

The value in this register is used as the upper 14 bits of the interrupt vector VAB[20:0]. The lower 7 bits are determined based on the highest priority interrupt and are then appended onto VBA before presenting the full VAB to the Core.

### 5.6.7 Fast Interrupt Match 0 Register (FIM0)

Base + \$6	15	14	13	12	11	10	9	8	7	6	5	4	3	2	1	0
Read	0	0	0	0	0	0	0	0	0	0	FAST INTERRUPT 0					
Write																
RESET	0	0	0	0	0	0	0	0	0	0	0	0	0	0	0	0

Figure 5-9 Fast Interrupt Match 0 Register (FIM0)

### 5.6.7.1 Reserved—Bits 15–6

This bit field is reserved or not implemented. It is read as 0 and cannot be modified by writing.

### 5.6.7.2 Fast Interrupt 0 Vector Number (FAST INTERRUPT 0)—Bits 5–0

These values determine which IRQ will be Fast Interrupt 0. Fast Interrupts vector directly to a service routine based on values in the Fast Interrupt Vector Address registers without having to go to a jump table first. IRQs used as Fast Interrupts *must* be set to priority level 2. Unexpected results will occur if a Fast Interrupt vector is set to any other priority. A Fast Interrupt automatically becomes the highest-priority level 2 interrupt regardless of its location in the interrupt table prior to being declared as Fast Interrupt. Fast Interrupt 0 has priority over fast Interrupt 1. To determine the vector number of each IRQ, refer to the vector table.

## 5.6.8 Fast Interrupt 0 Vector Address Low Register (FIVAL0)

Base + \$7	15	14	13	12	11	10	9	8	7	6	5	4	3	2	1	0
Read	FAST INTERRUPT 0 VECTOR ADDRESS LOW															
Write																
RESET	0	0	0	0	0	0	0	0	0	0	0	0	0	0	0	0

Figure 5-10 Fast Interrupt 0 Vector Address Low Register (FIVAL0)

### 5.6.8.1 Fast Interrupt 0 Vector Address Low (FIVAL0)—Bits 15–0

The lower 16 bits of the vector address used for Fast Interrupt 0. This register is combined with FIVAH0 to form the 21-bit vector address for Fast Interrupt 0 defined in the FIM0 register.

## 5.6.9 Fast Interrupt 0 Vector Address High Register (FIVAH0)

Base + \$8	15	14	13	12	11	10	9	8	7	6	5	4	3	2	1	0
Read	0	0	0	0	0	0	0	0	0	0	0	FAST INTERRUPT 0 VECTOR ADDRESS HIGH				
Write																
RESET	0	0	0	0	0	0	0	0	0	0	0	0	0	0	0	0

Figure 5-11 Fast Interrupt 0 Vector Address High Register (FIVAH0)

### 5.6.9.1 Reserved—Bits 15–5

This bit field is reserved or not implemented. It is read as 0 and cannot be modified by writing.

### 5.6.9.2 Fast Interrupt 0 Vector Address High (FIVAH0)—Bits 4–0

The upper five bits of the vector address used for Fast Interrupt 0. This register is combined with FIVAL0 to form the 21-bit vector address for Fast Interrupt 0 defined in the FIM0 register.

## 5.6.10 Fast Interrupt 1 Match Register (FIM1)

Base + \$9	15	14	13	12	11	10	9	8	7	6	5	4	3	2	1	0
Read	0	0	0	0	0	0	0	0	0	0	FAST INTERRUPT 1					
Write																
RESET	0	0	0	0	0	0	0	0	0	0	0	0	0	0	0	0

Figure 5-12 Fast Interrupt 1 Match Register (FIM1)

### 5.6.10.1 Reserved—Bits 15–6

This bit field is reserved or not implemented. It is read as 0 and cannot be modified by writing.

### 5.6.10.2 Fast Interrupt 1 Vector Number (FAST INTERRUPT 1)—Bits 5–0

These values determine which IRQ will be Fast Interrupt 1. Fast Interrupts vector directly to a service routine based on values in the Fast Interrupt Vector Address registers without having to go to a jump table first. IRQs used as Fast Interrupts *must* be set to priority level 2. Unexpected results will occur if a Fast Interrupt vector is set to any other priority. A Fast Interrupt automatically becomes the highest-priority level 2 interrupt regardless of its location in the interrupt table prior to being declared as Fast Interrupt. Fast Interrupt 0 has priority over Fast Interrupt 1. To determine the vector number of each IRQ, refer to the vector table.

## 5.6.11 Fast Interrupt 1 Vector Address Low Register (FIVAL1)

Base + \$A	15	14	13	12	11	10	9	8	7	6	5	4	3	2	1	0
Read	FAST INTERRUPT 1 VECTOR ADDRESS LOW															
Write																
RESET	0	0	0	0	0	0	0	0	0	0	0	0	0	0	0	0

Figure 5-13 Fast Interrupt 1 Vector Address Low Register (FIVAL1)

### 5.6.11.1 Fast Interrupt 1 Vector Address Low (FIVAL1)—Bits 15–0

The lower 16 bits of the vector address used for Fast Interrupt 1. This register is combined with FIVAH1 to form the 21-bit vector address for Fast Interrupt 1 defined in the FIM1 register.

## 5.6.12 Fast Interrupt 1 Vector Address High Register (FIVAH1)

Base + \$B	15	14	13	12	11	10	9	8	7	6	5	4	3	2	1	0
Read	0	0	0	0	0	0	0	0	0	0	0	FAST INTERRUPT 1 VECTOR ADDRESS HIGH				
Write																
RESET	0	0	0	0	0	0	0	0	0	0	0	0	0	0	0	0

Figure 5-14 Fast Interrupt 1 Vector Address High Register (FIVAH1)

### 5.6.12.1 Reserved—Bits 15–5

This bit field is reserved or not implemented. It is read as 0 and cannot be modified by writing.

### 5.6.12.2 Fast Interrupt 1 Vector Address High (FIVAH1)—Bits 4–0

The upper five bits of the vector address are used for Fast Interrupt 1. This register is combined with FIVAL1 to form the 21-bit vector address for Fast Interrupt 1 defined in the FIM1 register.

### 5.6.13 IRQ Pending Register 0 (IRQP0)

Base + \$C	15	14	13	12	11	10	9	8	7	6	5	4	3	2	1	0
Read	PENDING[16:2]															1
Write																
RESET	1	1	1	1	1	1	1	1	1	1	1	1	1	1	1	1

Figure 5-15 IRQ Pending Register 0 (IRQP0)

### 5.6.13.1 IRQ Pending (PENDING)—Bits 15–1

This register combines with IRQP1 and IRQP2 to represent the pending IRQs for interrupt vector numbers 2 through 45.

- 0 = IRQ pending for this vector number
- 1 = No IRQ pending for this vector number

### 5.6.13.2 Reserved—Bit 0

This bit is reserved or not implemented. It is read as 1 and cannot be modified by writing.

### 5.6.14 IRQ Pending Register 1 (IRQP1)

Base + \$D	15	14	13	12	11	10	9	8	7	6	5	4	3	2	1	0
Read	PENDING[32:17]															
Write																
RESET	1	1	1	1	1	1	1	1	1	1	1	1	1	1	1	1

Figure 5-16 IRQ Pending Register 1 (IRQP1)

### 5.6.14.1 IRQ Pending (PENDING)—Bits 32–17

This register combines with IRQP0 and IRQP2 to represent the pending IRQs for interrupt vector numbers 2 through 45.

- 0 = IRQ pending for this vector number
- 1 = No IRQ pending for this vector number

### 5.6.15 IRQ Pending Register 2 (IRQP2)

Base + \$E	15	14	13	12	11	10	9	8	7	6	5	4	3	2	1	0
Read	1	1	1	PENDING[45:33]												
Write																
RESET	1	1	1	1	1	1	1	1	1	1	1	1	1	1	1	1

Figure 5-17 IRQ Pending Register 2 (IRQP2)

### 5.6.15.1 IRQ Pending (PENDING)—Bits 45–33

This register combines with IRQP0 and IRQP1 to represent the pending IRQs for interrupt vector numbers 2 through 45.

- 0 = IRQ pending for this vector number
- 1 = No IRQ pending for this vector number

### 5.6.16 Interrupt Control Register (ICTRL)

\$Base + \$12	15	14	13	12	11	10	9	8	7	6	5	4	3	2	1	0	
Read	INT	IPIC		VAB								INT_	1	1	1	0	0
Write											DIS						
RESET	0	0	0	0	0	0	0	0	0	0	0	1	1	1	0	0	

Figure 5-18 Interrupt Control Register (ICTRL)

#### 5.6.16.1 Interrupt (INT)—Bit 15

This *read-only* bit reflects the state of the interrupt to the 56800E core.

- 0 = No interrupt is being sent to the 56800E core
- 1 = An interrupt is being sent to the 56800E core

#### 5.6.16.2 Interrupt Priority Level (IPIC)—Bits 14–13

These *read-only* bits reflect the state of the new interrupt priority level bits being presented to the 56800E core. These bits indicate the priority level needed for a new IRQ to interrupt the current interrupt being sent to the 56800E core. This field is only updated when the 56800E core jumps to a new interrupt service routine.

**Note:** Nested interrupts may cause this field to be updated before the original interrupt service routine can read it.

- 00 = Required nested exception priority levels are 0, 1, 2, or 3
- 01 = Required nested exception priority levels are 1, 2, or 3
- 10 = Required nested exception priority levels are 2 or 3
- 11 = Required nested exception priority level is 3

Table 5-3 Interrupt Priority Encoding

IPIC_VALUE[1:0]	Current Interrupt Priority Level	Required Nested Exception Priority
00	No interrupt or SWILP	Priorities 0, 1, 2, 3
01	Priority 0	Priorities 1, 2, 3
10	Priority 1	Priorities 2, 3
11	Priority 2 or 3	Priority 3

### 5.6.16.3 Vector Number - Vector Address Bus (VAB)—Bits 12–6

This *read-only* field shows the vector number (VAB[6:0]) used at the time the last IRQ was taken. In the case of a Fast Interrupt, it shows the lower address bits of the jump address. This field is only updated when the 56800E core jumps to a new interrupt service routine.

**Note:** Nested interrupts may cause this field to be updated before the original interrupt service routine can read it.

### 5.6.16.4 Interrupt Disable (INT\_DIS)—Bit 5

This bit allows all interrupts to be disabled.

- 0 = Normal operation (default)
- 1 = All interrupts disabled

### 5.6.16.5 Reserved—Bits 4–2

This bit field is reserved or not implemented. It is read as 1 and cannot be modified by writing.

### 5.6.16.6 Reserved—Bits 1–0

This bit field is reserved or not implemented. It is read as 0 and cannot be modified by writing.

## 5.7 Resets

### 5.7.1 General

**Table 5-4 Reset Summary**

Reset	Priority	Source	Characteristics
Core Reset		RST	Core reset from the SIM

### 5.7.2 Description of Reset Operation

#### 5.7.2.1 Reset Handshake Timing

The ITCN provides the 56800E core with a reset vector address on the VAB pins whenever  $\overline{\text{RESET}}$  is asserted from the SIM. The reset vector will be presented until the second rising clock edge after  $\overline{\text{RESET}}$  is released. The general timing is shown in [Figure 5-19](#).

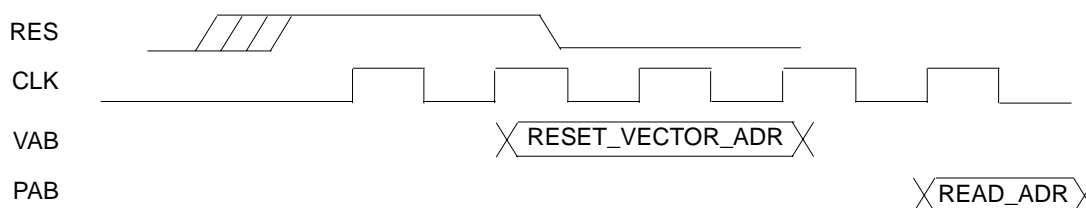

**Figure 5-19 Reset Interface**

### 5.7.3 ITCN After Reset

After reset, all of the ITCN registers are in their default states. This means all interrupts are disabled, except the core IRQs with fixed priorities:

- Illegal Instruction
- SW Interrupt 3
- HW Stack Overflow
- Misaligned Long Word Access
- SW Interrupt 2
- SW Interrupt 1
- SW Interrupt 0
- SW Interrupt LP

These interrupts are enabled at their fixed priority levels.

## Part 6 System Integration Module (SIM)

### 6.1 Introduction

The SIM module is a system catchall for the glue logic that ties together the system-on-chip. It controls distribution of resets and clocks and provides a number of control features. The System Integration Module is responsible for the following functions:

- Reset sequencing
- Clock control & distribution
- Stop/Wait control
- System status registers
- Registers for software access to the JTAG ID of the chip
- Test registers
- Power control
- I/O pad multiplexing

These are discussed in more detail in the sections that follow.

### 6.2 Features

The SIM has the following features:

- System bus clocks with pipeline hold-off support
- System clocks for non-pipelined interfaces
- Peripheral clocks for TMR and PWM with high-speed (3X) option
- Power-saving clock gating for peripherals
- ITCK clock to the 56800E core TAP interface
- Three power modes (Run, Wait, Stop) to control power utilization
  - Stop mode shuts down the 56800E core, system clock, and peripheral clock
  - Wait mode shuts down the 56800E core and unnecessary system clock operation
  - Run mode supports full part operation
- Controls, with write protection, the enable/disable of 56800E core WAIT and STOP instructions
- Controls, with write protection, the enable/disable of Large Regulator Standby mode
- Controls to route functional signals to selected peripherals and I/O pads
- Controls deassertion sequence of internal resets
- Software-initiated reset
- Four 16-bit registers reset only by a Power-On Reset usable for general-purpose software control
- Timer channel Stop mode clocking controls
- SCI Stop mode clocking control to support LIN Sleep mode stop recovery
- Short addressing location control
- Registers for software access to the JTAG ID of the chip
- Controls output to CLKO pin

## 6.3 Register Descriptions

**Table 6-1 SIM Registers (SIM\_BASE = \$00 F140)**

Address Offset	Address Acronym	Register Name	Section Location
Base + \$0	SIM_CTRL	Control Register	<a href="#">6.3.1</a>
Base + \$1	SIM_RSTAT	Reset Status Register	<a href="#">6.3.2</a>
Base + \$2	SIM_SWC0	Software Control Register 0	<a href="#">6.3.3</a>
Base + \$3	SIM_SWC1	Software Control Register 1	<a href="#">6.3.3</a>
Base + \$4	SIM_SWC2	Software Control Register 2	<a href="#">6.3.3</a>
Base + \$5	SIM_SWC3	Software Control Register 3	<a href="#">6.3.3</a>
Base + \$6	SIM_MSHID	Most Significant Half of JTAG ID	<a href="#">6.3.4</a>
Base + \$7	SIM_LSHID	Least Significant Half of JTAG ID	<a href="#">6.3.5</a>
Base + \$8	SIM_PWR	Power Control Register	<a href="#">6.3.6</a>
		Reserved	
Base + \$A	SIM_CLKOUT	CLKO Select Register	<a href="#">6.3.7</a>
Base + \$B	SIM_GPS	GPIO Peripheral Select Register	<a href="#">6.3.8</a>
Base + \$C	SIM_PCE	Peripheral Clock Enable Register	<a href="#">6.3.9</a>
Base + \$D	SIM_IOSAHI	I/O Short Address Location High Register	<a href="#">6.3.10</a>
Base + \$E	SIM_IOSALO	I/O Short Address Location Low Register	<a href="#">6.3.10</a>

Add. Offset	Address Acronym		15	14	13	12	11	10	9	8	7	6	5	4	3	2	1	0
\$0	SIM_CTRL	R	TC3_SD	TC2_SD	TC1_SD	TC0_SD	SCI_SD	0	TC3_INP	0	0	0	ONCE_EBL	SW_RST	STOP_DISABLE		WAIT_DISABLE	
\$1	SIM_RSTAT	R	0	0	0	0	0	0	0	0	0	0	SWR	COPR	EXTR	POR	0	0
\$2	SIM_SWC0	R	Software Control Data 0															
\$3	SIM_SWC1	R	Software Control Data 1															
\$4	SIM_SWC2	R	Software Control Data 2															
\$5	SIM_SWC3	R	Software Control Data 3															
\$6	SIM_MSHID	R	0	0	0	0	0	0	0	1	1	1	1	1	0	0	1	0
\$7	SIM_LSHID	R	0	1	0	0	0	0	0	0	0	0	0	1	1	1	0	1
\$8	SIM_PWR	R	0	0	0	0	0	0	0	0	0	0	0	0	0	0	LRSTDBY	
	Reserved																	
\$A	SIM_CLKOUT	R	0	0	0	0	0	0	PWM3	PWM2	PWM1	PWM0	CLK_DIS	CLKOSEL				
\$B	SIM_GPS	R	TCR	PCR	0	0	CFG_B7	CFG_B6	CFG_B5	CFG_B4	CFG_B3	CFG_B2	CFG_B1	CFG_B0	CFG_A5	CFG_A4		
\$C	SIM_PCE	R	I2C	0	ADC	0	0	0	0	0	0	TMR	0	SCI	0	SPI	0	PWM
\$D	SIM_IOSAHI	R	0	0	0	0	0	0	0	0	0	0	0	0	0	ISAL[23:22]		
\$E	SIM_IOSALO	R	ISAL[21:6]															

= Read as 0     
 = Read as 1  
 = Reserved     
 = Reserved

**Figure 6-1 SIM Register Map Summary**

### 6.3.1 SIM Control Register (SIM\_CTRL)

Base + \$0	15	14	13	12	11	10	9	8	7	6	5	4	3	2	1	0
<b>Read</b>	TC3_SD	TC2_SD	TC1_SD	TC0_SD	SCI_SD	0	TC3_INP	0	0	0	ONCE_EBL	SW_RST	STOP_DISABLE		WAIT_DISABLE	
<b>Write</b>																
<b>RESET</b>	0	0	0	0	0	0	0	0	0	0	0	0	0	0	0	0

**Figure 6-2 SIM Control Register (SIM\_CTRL)**

### 6.3.1.1 Timer Channel 3 Stop Disable (TC3\_SD)—Bit 15

This bit enables the operation of the Timer Channel 3 peripheral clock in Stop mode.

- 0 = Timer Channel 3 disabled in Stop mode
- 1 = Timer Channel 3 enabled in Stop mode

### 6.3.1.2 Timer Channel 2 Stop Disable (TC2\_SD)—Bit 14

This bit enables the operation of the Timer Channel 2 peripheral clock in Stop mode.

- 0 = Timer Channel 2 disabled in Stop mode
- 1 = Timer Channel 2 enabled in Stop mode

### 6.3.1.3 Timer Channel 1 Stop Disable (TC1\_SD)—Bit 13

This bit enables the operation of the Timer Channel 1 peripheral clock in Stop mode.

- 0 = Timer Channel 1 disabled in Stop mode
- 1 = Timer Channel 1 enabled in Stop mode

### 6.3.1.4 Timer Channel 0 Stop Disable (TC0\_SD)—Bit 12

This bit enables the operation of the Timer Channel 0 peripheral clock in Stop mode.

- 0 = Timer Channel 0 disabled in Stop mode
- 1 = Timer Channel 0 enabled in Stop mode

### 6.3.1.5 SCI Stop Disable (SCI\_SD)—Bit 11

This bit enables the operation of the SCI peripheral clock in Stop mode. This is recommended for use in LIN mode so that the SCI can generate interrupts and recover from Stop mode while the LIN interface is in Sleep mode and using Stop mode to reduce power consumption.

- 0 = SCI disabled in Stop mode
- 1 = SCI enabled in Stop mode

### 6.3.1.6 Reserved—Bit 10

This bit field is reserved or not implemented. It is read as 0 and cannot be modified by writing.

### 6.3.1.7 Timer Channel 3 Input (TC3\_INP)—Bit 9

This bit selects the input of Timer Channel 3 to be from the PWM or GPIO.

- 1 = Timer Channel 3 Input from PWM reload\_sync signal
- 0 = Timer Channel 3 Input controlled by SIM\_GPS register CFG\_B3 and CFG\_A5 fields

### 6.3.1.8 Reserved—Bits 8–6

This bit field is reserved or not implemented. It is read as 0 and cannot be modified by writing.

### 6.3.1.9 OnCE Enable (ONCEEBL)—Bit 5

- 0 = OnCE clock to 56800E core enabled when core TAP is enabled
- 1 = OnCE clock to 56800E core is always enabled

### 6.3.1.10 Software Reset (SWRST)—Bit 4

Writing 1 to this field will cause the part to reset.

### 6.3.1.11 Stop Disable (STOP\_DISABLE[1:0])—Bits 3–2

- 00 = Stop mode will be entered when the 56800E core executes a STOP instruction
- 01 = The 56800E STOP instruction will not cause entry into Stop mode
- 10 = Stop mode will be entered when the 56800E core executes a STOP instruction and the STOP\_DISABLE field is write-protected until the next reset
- 11 = The 56800E STOP instruction will not cause entry into Stop mode and the STOP\_DISABLE field is write-protected until the next reset

### 6.3.1.12 Wait Disable (WAIT\_DISABLE[1:0])—Bits 1–0

- 00 = Wait mode will be entered when the 56800E core executes a WAIT instruction
- 01 = The 56800E WAIT instruction will not cause entry into Wait mode
- 10 = Wait mode will be entered when the 56800E core executes a WAIT instruction and the WAIT\_DISABLE field is write-protected until the next reset
- 11 = The 56800E WAIT instruction will not cause entry into Wait mode and the WAIT\_DISABLE field is write-protected until the next reset

## 6.3.2 SIM Reset Status Register (SIM\_RSTAT)

This register is updated upon any system reset and indicates the cause of the most recent reset. It also controls whether the COP reset vector or regular reset vector in the vector table is used. This register is asynchronously reset during Power-On Reset (see power supervisor module) and subsequently is synchronously updated based on the level of the external reset, software reset, or cop reset inputs. Only one source will ever be indicated. In the event that multiple reset sources assert simultaneously, the highest-precedence source will be indicated. The precedence from highest to lowest is POR, EXTR, COPR, and SWR. While POR is always set during a Power-On Reset, EXTR will become set if the external reset pin is asserted or remains asserted after the Power-On Reset (POR) has deasserted.

Base + \$1	15	14	13	12	11	10	9	8	7	6	5	4	3	2	1	0
Read	0	0	0	0	0	0	0	0	0	0	SWR	COPR	EXTR	POR	0	0
Write																
RESET	0	0	0	0	0	0	0	0	0	0					0	0

Figure 6-3 SIM Reset Status Register (SIM\_RSTAT)

### 6.3.2.1 Reserved—Bits 15–6

This bit field is reserved or not implemented. It is read as zero and cannot be modified by writing.

### 6.3.2.2 Software Reset (SWR)—Bit 5

When set, this bit indicates that the previous system reset occurred as a result of a software reset (written 1 to SW RST bit in the SIM\_CTRL register). It will not be set if a COP, external, or POR reset also occurred.

### 6.3.2.3 COP Reset (COPR)—Bit 4

When set, this bit indicates that the previous system reset was caused by the Computer Operating Properly (COP) timer. It will not be set if an external or POR reset also occurred. If COPR is set as code starts executing, the COP reset vector in the vector table will be used. Otherwise, the normal reset vector is used.

### 6.3.2.4 External Reset (EXTR)—Bit 3

When set, this bit indicates that the previous system reset was caused by an external reset. It will only be set if the external reset pin was asserted or remained asserted after the Power-On Reset deasserted.

### 6.3.2.5 Power-On Reset (POR)—Bit 2

This bit is set during a Power-On Reset.

### 6.3.2.6 Reserved—Bits 1–0

This bit field is reserved or not implemented. It is read as 0 and cannot be modified by writing.

## 6.3.3 SIM Software Control Registers (SIM\_SWC0, SIM\_SWC1, SIM\_SWC2, and SIM\_SWC3)

Only SIM\_SWC0 is shown in this section. SIM\_SWC1, SIM\_SWC2, and SIM\_SWC3 are identical in functionality.

Base + \$2	15	14	13	12	11	10	9	8	7	6	5	4	3	2	1	0
Read	Software Control Data 0															
Write																
RESET	0	0	0	0	0	0	0	0	0	0	0	0	0	0	0	0

Figure 6-4 SIM Software Control Register 0 (SIM\_SWC0)

### 6.3.3.1 Software Control Data 0 (FIELD)—Bits 15–0

This register is reset only by the Power-On Reset (POR). It has no part-specific functionality and is intended for use by a software developer to contain data that will be unaffected by the other reset sources ( $\overline{\text{RESET}}$  pin, software reset, and COP reset).

### 6.3.4 Most Significant Half of JTAG ID (SIM\_MSHID)

This read-only register displays the most significant half of the JTAG ID for the chip. This register reads \$01F2.

Base + \$6	15	14	13	12	11	10	9	8	7	6	5	4	3	2	1	0
Read	0	0	0	0	0	0	0	1	1	1	1	1	0	0	1	0
Write																
RESET	0	0	0	0	0	0	0	1	1	1	1	1	0	0	1	0

**Figure 6-5 Most Significant Half of JTAG ID (SIM\_MSHID)**

### 6.3.5 Least Significant Half of JTAG ID (SIM\_LSHID)

This read-only register displays the least significant half of the JTAG ID for the chip. This register reads \$401D.

Base + \$7	15	14	13	12	11	10	9	8	7	6	5	4	3	2	1	0
Read	0	1	0	0	0	0	0	0	0	0	0	1	1	1	0	1
Write																
RESET	0	1	0	0	0	0	0	0	0	0	0	1	1	1	0	1

**Figure 6-6 Least Significant Half of JTAG ID (SIM\_LSHID)**

### 6.3.6 SIM Power Control Register (SIM\_PWR)

This register controls the Standby mode of the large regulator. The large regulator derives the core digital logic power supply from the IO power supply. In some circumstances, the large regulator may be put in a reduced-power Standby mode without interfering with part operation. Refer to the overview of power-down modes and the overview of clock generation for more information on the use of large regulator standby.

Base + \$8	15	14	13	12	11	10	9	8	7	6	5	4	3	2	1	0
Read	0	0	0	0	0	0	0	0	0	0	0	0	0	0	LRSTDBY	
Write																
RESET	0	0	0	0	0	0	0	0	0	0	0	0	0	0	0	0

**Figure 6-7 SIM Power Control Register (SIM\_PWR)**

#### 6.3.6.1 Reserved—Bits 15–2

This bit field is reserved or not implemented. It is read as 0 and cannot be modified by writing.

#### 6.3.6.2 Large Regulator Standby Mode[1:0] (LRSTDBY)—Bits 1–0

This bit controls the pull-up resistors on the IRQA pin.

- 00 = Large regulator is in Normal mode
- 01 = Large regulator is in Standby (reduced-power) mode
- 10 = Large regulator is in Normal mode and the LRSTDBY field is write-protected until the next reset
- 11 = Large regulator is in Standby mode and the LRSTDBY field is write-protected until the next reset

### 6.3.7 CLKO Select Register (SIM\_CLKOUT)

The CLKO select register can be used to multiplex out selected clocks generated inside the clock generation and SIM modules. All functionality is for test purposes only and is subject to unspecified latencies. Glitches may be produced when the clock is enabled or switched.

The lower four bits of the GPIO A register can function as GPIO, PWM, or as additional clock output signals. GPIO has priority and is enabled/disabled via the GPIOA\_PEREN. If GPIOA[3:0] are programmed to operate as peripheral outputs, then the choice between PWM and additional clock outputs is done here in the CLKOUT. The default state is for the peripheral function of GPIOA[3:0] to be programmed as PWM. This can be changed by altering  $\overline{\text{PWM}}3$  through  $\overline{\text{PWM}}0$ .

Base + \$A	15	14	13	12	11	10	9	8	7	6	5	4	3	2	1	0
Read	0	0	0	0	0	0	$\overline{\text{PWM}}3$	$\overline{\text{PWM}}2$	$\overline{\text{PWM}}1$	$\overline{\text{PWM}}0$	CLK DIS	CLKOSEL				
Write																
RESET	0	0	0	0	0	0	0	0	0	0	1	0	0	0	0	0

Figure 6-8 CLKO Select Register (SIM\_CLKOUT)

#### 6.3.7.1 Reserved—Bits 15–10

This bit field is reserved or not implemented. It is read as 0 and cannot be modified by writing.

#### 6.3.7.2 $\overline{\text{PWM}}3$ —Bit 9

- 0 = Peripheral output function of GPIOA[3] is defined to be  $\overline{\text{PWM}}3$
- 1 = Peripheral output function of GPIOA[3] is defined to be the Relaxation Oscillator Clock

#### 6.3.7.3 $\overline{\text{PWM}}2$ —Bit 8

- 0 = Peripheral output function of GPIOA[2] is defined to be  $\overline{\text{PWM}}2$
- 1 = Peripheral output function of GPIOA[2] is defined to be the system clock

#### 6.3.7.4 $\overline{\text{PWM}}1$ —Bit 7

- 0 = Peripheral output function of GPIOA[1] is defined to be  $\overline{\text{PWM}}1$
- 1 = Peripheral output function of GPIOA[1] is defined to be two times the rate of the system clock

#### 6.3.7.5 $\overline{\text{PWM}}0$ —Bit 6

- 0 = Peripheral output function of GPIOA[0] is defined to be  $\overline{\text{PWM}}0$
- 1 = Peripheral output function of GPIOA[0] is defined to be three times the rate of the system clock

#### 6.3.7.6 Clockout Disable (CLKDIS)—Bit 5

- 0 = CLKOUT output is enabled and will output the signal indicated by CLKOSEL
- 1 = CLKOUT is 0

### 6.3.7.7 Clockout Select (CLKOSEL)—Bits 4–0

Selects clock to be muxed out on the CLKO pin.

- 00000 = Reserved for factory test—Continuous system clock
- 01001 = Reserved for factory test—OCCS MSTR OSC clock
- 01011 = Reserved for factory test—ADC clock
- 01100 = Reserved for factory test—JTAG TCLK
- 01101 = Reserved for factory test—Continuous peripheral clock
- 01110 = Reserved for factory test—Continuous inverted peripheral clock
- 01111 = Reserved for factory test—Continuous high-speed peripheral clock

### 6.3.8 SIM GPIO Peripheral Select Register (SIM\_GPS)

All of the peripheral pins on the 56F8014 share their Input/Output (I/O) with GPIO ports. In order to select peripheral or GPIO control, program the GPIO<sub>x</sub>\_PEREN register. In some cases, there are two possible peripherals as well as the GPIO functionality available for control of the I/O. In these cases, the SIM\_GPS register is used to determine which peripheral has control.

As shown in [Figure 6-9](#), the GPIO Peripheral Enable Register (PEREN) has the final control over which pin controls the I/O. SIM\_GPS simply decides which peripheral will be routed to the I/O when PEREN = 1.

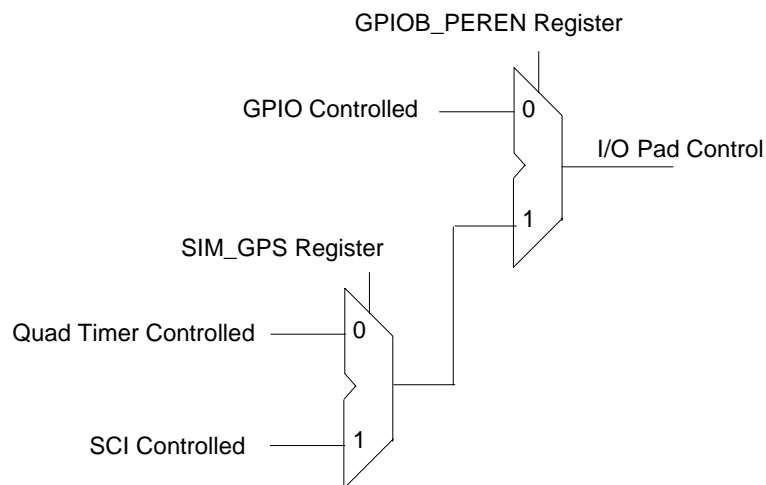

**Figure 6-9 Overall Control of Pads Using SIM\_GPS Control**

Base + \$B	15	14	13	12	11	10	9	8	7	6	5	4	3	2	1	0
Read	TCR	PCR	0	0	CFG_ B7	CFG_ B6	CFG_ B5	CFG_ B4	CFG_ B3	CFG_ B2	CFG_ B1	CFG_ B0	CFG_A5		CFG_A4	
Write																
RESET	0	0	0	0	0	0	0	0	0	0	0	0	0	0	0	0

**Figure 6-10 GPIO Peripheral Select Register (SIM\_GPS)**

### 6.3.8.1 TMR Clock Rate (TCR)—Bit 15

This bit selects the clock speed for the TMR module.

- 0 = TMR module clock rate equals core clock rate, typically 32MHz (default)
- 1 = TMR module clock rate equals three times core clock rate

**Note:** This bit should only be changed while the TMR module's clock is disabled. See [Section 6.3.9](#).

**Note:** High-speed clocking is only available when the PLL is being used.

**Note:** If the PWM reload pulse is used as input to Timer 3 (See SIM\_CTRL: TC3\_INP, [Section 6.3.1.7](#)), then the clocks of the Quad Timer and PWM must be related, as shown in [Table 6-2](#).

### 6.3.8.2 PWM Clock Rate (PCR)—Bit 14

This bit selects the clock speed for the PWM module.

- 0 = PWM module clock rate equals core clock rate, typically 32MHz (default)
- 1 = PWM module clock rate equals three times core clock rate

**Note:** This bit should only be changed while the PWM module's clock is disabled. See [Section 6.3.9](#).

**Note:** High-speed clocking is only available when the PLL is being used.

**Note:** If the PWM reload pulse is used as input to Timer 3 (See SIM\_CTRL: TC3\_INP, [Section 6.3.1.7](#)), then the clocks of the Quad Timer and PWM must be related, as shown in [Table 6-2](#).

**Table 6-2 Allowable Quad Timer and PWM Clock Rates when Using PWM Reload Pulse**

		Quad Timer	
Clock Speed		1X	3X
PWM	1X	OK	OK
	3X	NO	OK

### 6.3.8.3 Reserved—Bits 13–12

This bit field is reserved or not implemented. It is read as 0 and cannot be modified by writing.

**Note:** Take care when programming the following CFG\_\* signals so as not to connect two different I/O pads to the same peripheral input. For example, do not set CFG\_B7 to select SCL and also set CFG\_B0 to select SCL. If this occurs for an output signal, then the signal will be routed to two I/O pads. For input signals, the values on the two I/O pads will be ORed together before reaching the peripheral.

### 6.3.8.4 Configure GPIOB7 (CFG\_B7)—Bit 11

This bit selects the alternate function for GPIOB7.

- 0 = TXD (default)
- 1 = SCL

### 6.3.8.5 Configure GPIOB6 (CFG\_B6)—Bit 10

This bit selects the alternate function for GPIOB6.

- 0 = RXD (default)
- 1 = SDA

**Note:** The CLKMODE bit in the OCCS Oscillator Control register can enable this pin as the source clock to the chip. In this mode, make sure that no on-chip peripheral (including the GPIO) is driving this pin.

### 6.3.8.6 Configure GPIOB5 (CFG\_B5)—Bit 9

This bit selects the alternate function for GPIOB5.

- 0 = T1 (default)
- 1 = FAULT3

### 6.3.8.7 Configure GPIOB4 (CFG\_B4)—Bit 8

This bit selects the alternate function for GPIOB4.

- 0 = T0 (default)
- 1 = CLKO

### 6.3.8.8 Configure GPIOB3 (CFG\_B3)—Bit 7

This bit selects the alternate function for GPIOB3.

- 0 = MOSI (default)
- 1 = T3

### 6.3.8.9 Configure GPIOB2 (CFG\_B2)—Bit 6

This bit selects the alternate function for GPIOB2.

- 0 = MISO (default)
- 1 = T2

### 6.3.8.10 Configure GPIOB1 (CFG\_B1)—Bit 5

This bit selects the alternate function for GPIOB1.

- 0 =  $\overline{SS}$  (default)
- 1 = SDA

### 6.3.8.11 Configure GPIOB0 (CFG\_B0)—Bit 4

This bit selects the alternate function for GPIOB0.

- 0 = SCLK (default)
- 1 = SCL

### 6.3.8.12 Configure GPIOA5[1:0] (CFG\_A5)—Bits 3–2

These bits select the alternate function for GPIOA5.

- 00 = Select PWM5 when peripheral mode is enabled in GPIOA5 (default)
- 01 = Select PWM5 when peripheral mode is enabled in GPIOA5
- 10 = Select FAULT2 when peripheral mode is enabled in GPIOA5
- 11 = Select T3 when peripheral mode is enabled in GPIOA5

### 6.3.8.13 Configure GPIOA4[1:0] (CFG\_A4)—Bits 1–0

These bits select the alternate function for GPIOA4.

- 00 = Select PWM4 when peripheral mode is enabled in GPIOA4 (default)
- 01 = Select PWM4 when peripheral mode is enabled in GPIOA4
- 10 = Select FAULT1 when peripheral mode is enabled in GPIOA4
- 11 = Select T2 when peripheral mode is enabled in GPIOA4

## 6.3.9 Peripheral Clock Enable Register (SIM\_PCE)

The Peripheral Clock Enable register is used to enable or disable clocks to the peripherals as a power savings feature. The clocks can be individually controlled for each peripheral on the chip. The corresponding peripheral should itself be disabled while its clock is shut off. IPBus writes cannot be made to a module that has its clock disabled.

Base + \$C	15	14	13	12	11	10	9	8	7	6	5	4	3	2	1	0
Read	I2C	0	ADC	0	0	0	0	0	0	TMR	0	SCI	0	SPI	0	PWM
Write																
RESET	0	0	0	0	0	0	0	0	0	0	0	0	0	0	0	0

Figure 6-11 Peripheral Clock Enable Register (SIM\_PCE)

### 6.3.9.1 I<sup>2</sup>C IPBus Clock Enable (I2C)—Bit 15

Each bit controls clocks to the indicated peripheral.

- 0 = The clock is not provided to the peripheral (the peripheral is disabled)
- 1 = Clocks are enabled

### 6.3.9.2 Reserved—Bit 14

This bit field is reserved or not implemented. It is read as 0 and cannot be modified by writing.

### 6.3.9.3 Analog-to-Digital Converter IPBus Clock Enable (ADC)—Bit 13

Each bit controls clocks to the indicated peripheral.

- 0 = The clock is not provided to the peripheral (the peripheral is disabled)
- 1 = Clocks are enabled

### 6.3.9.4 Reserved—Bits 12–7

This bit field is reserved or not implemented. It is read as 0 and cannot be modified by writing.

### 6.3.9.5 Timer IPBus Clock Enable (TMR)—Bit 6

Each bit controls clocks to the indicated peripheral.

- 0 = The clock is not provided to the peripheral (the peripheral is disabled)
- 1 = Clocks are enabled

### 6.3.9.6 Reserved—Bit 5

This bit field is reserved or not implemented. It is read as 0 and cannot be modified by writing.

### 6.3.9.7 SCI IPBus Clock Enable (SCI)—Bit 4

Each bit controls clocks to the indicated peripheral.

- 0 = The clock is not provided to the peripheral (the peripheral is disabled)
- 1 = Clocks are enabled

### 6.3.9.8 Reserved—Bit 3

This bit field is reserved or not implemented. It is read as 0 and cannot be modified by writing.

### 6.3.9.9 SPI IPBus Clock Enable (SPI)—Bit 2

Each bit controls clocks to the indicated peripheral.

- 0 = The clock is not provided to the peripheral (the peripheral is disabled)
- 1 = Clocks are enabled

### 6.3.9.10 Reserved—Bit 1

This bit field is reserved or not implemented. It is read as 0 and cannot be modified by writing.

### 6.3.9.11 PWM IPBus Clock Enable (PWM)—Bit 0

Each bit controls clocks to the indicated peripheral.

- 0 = The clock is not provided to the peripheral (the peripheral is disabled)
- 1 = Clocks are enabled

### 6.3.10 I/O Short Address Location Register (SIM\_IOSAHI and SIM\_IOSALO)

The I/O Short Address Location registers are used to specify the memory referenced via the I/O short address mode. The I/O short address mode allows the instruction to specify the lower six bits of address; the upper address bits are not directly controllable. This register set allows limited control of the full address, as shown in [Figure 6-12](#).

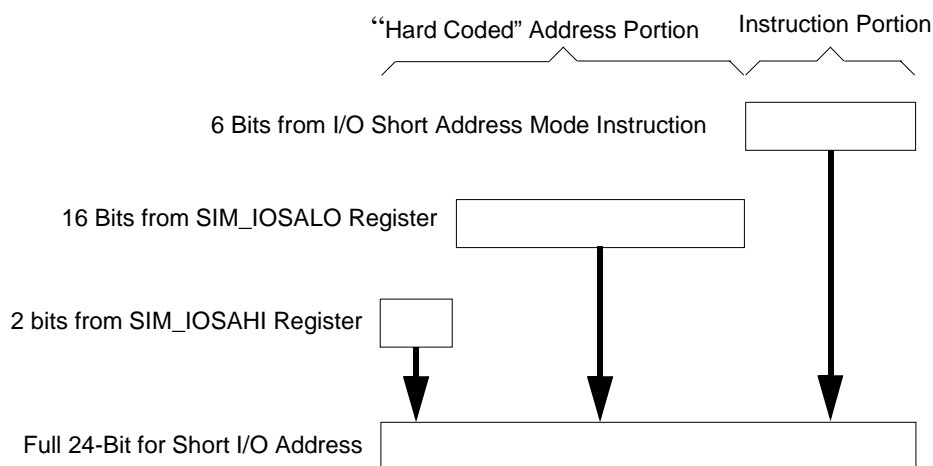

**Figure 6-12 I/O Short Address Determination**

With this register set, an interrupt driver can set the SIM\_IOSALO register pair to point to its peripheral registers and then use the I/O Short addressing mode to reference them. The ISR should restore this register to its previous contents prior to returning from interrupt.

**Note:** The default value of this register set points to the EOnCE registers.

**Note:** The pipeline delay between setting this register set and using short I/O addressing with the new value is five instruction cycles.

Base + \$D	15	14	13	12	11	10	9	8	7	6	5	4	3	2	1	0
Read	0	0	0	0	0	0	0	0	0	0	0	0	0	0	ISAL[23:22]	
Write																
RESET	0	0	0	0	0	0	0	0	0	0	0	0	0	0	1	1

**Figure 6-13 I/O Short Address Location High Register (SIM\_IOSAHI)**

#### 6.3.10.1 Reserved—Bits 15—2

This bit field is reserved or not implemented. It is read as 0 and cannot be modified by writing.

### 6.3.10.2 Input/Output Short Address Location (ISAL[23:22])—Bit 1–0

This field represents the upper two address bits of the “hard coded” I/O short address.

Base + \$E	15	14	13	12	11	10	9	8	7	6	5	4	3	2	1	0
Read	ISAL[21:6]															
Write																
RESET	1	1	1	1	1	1	1	1	1	1	1	1	1	1	1	1

Figure 6-14 I/O Short Address Location Low Register (SIM\_IOSALO)

### 6.3.10.3 Input/Output Short Address Location (ISAL[21:6])—Bit 15–0

This field represents the lower 16 address bits of the “hard coded” I/O short address.

## 6.4 Clock Generation Overview

The SIM uses master clocks from the OCCS module to produce the peripheral and system (core and memory) clocks. The HS\_PERF clock input from OCCS operates at three times the system and peripheral bus rate, or a maximum of 96MHz. The SYS\_CLK\_x2 clock input from OCCS operates at two times the system and peripheral bus rate, or a maximum of 64MHz. Peripheral and system clocks are generated at a maximum of 32MHz by dividing the SYS\_CLK\_x2 clock by two and gating it with appropriate power mode and clock gating controls. The PWM and TIMER peripheral clocks can optionally be generated at three times the normal rate at a maximum 96MHz. These clocks are generated by gating the HS\_PERF clock with appropriate power mode and clock gating controls.

The OCCS configuration controls the operating frequency of the SIM’s master clocks. In the OCCS, either an external clock or the relaxation oscillator can be selected as the master clock source (MSTR\_OSC). When selected, the relaxation oscillator can be operated at full speed (8MHz), standby speed (400kHz using ROSB), or powered down (using ROPD). An 8MHz MSTR\_OSC can be multiplied to 196MHz using the PLL and postscaled to provide a variety of high speed clock rates. Either the postscaled PLL output or MSTR\_OSC signal can be selected to produce the master clocks to the SIM. When the PLL is not selected, the HS\_PERF clock is disabled and the SYS\_CLK\_x2 clock is MSTR\_OSC.

In combination with the OCCS module, the SIM provides power modes (see [Section 6.5](#)), clock enables (SIM\_PCE register, CLK\_DIS, ONCE\_EBL), and clock rate controls (TCR, PCR) to provide flexible control of clocking and power utilization. The SIM’s clock enable controls can be used to disable individual clocks when not needed. The clock rate controls enable the high speed clocking option for the Timer channels and PWM but require the PLL to be on and selected. Refer to the **56F8300 Peripheral User Manual** for further details.

## 6.5 Power-Down Modes

The 56F8014 operates in one of five Power-Down modes, as shown in [Table 6-3](#).

**Table 6-3 Clock Operation in Power-Down Modes**

Mode	Core Clocks	Peripheral Clocks	Description
Run	Core and memory clocks disabled	Peripheral clocks enabled	Device is fully functional
Wait	Core and memory clocks disabled	Peripheral clocks enabled	Core executes WAIT instruction to enter this mode. Typically used for power-conscious applications. Possible recoveries from Wait mode to Run mode are: 1. Any interrupt 2. Executing a Debug mode entry command during the 56800E core JTAG interface 2. Any reset (POR, external, software, COP)
Stop	Master clock generation in the OCCS remains operational, but the SIM disables the generation of system and peripheral clocks.		Core executes STOP instruction to enter this mode. Possible recoveries from Stop mode to Run mode are: 1. Interrupt from TMR channels that have been configured to operate in Stop mode (TCx_SD) 2. Interrupt for SCI configured to operate in Stop mode (SCI_SD) 3. Low-voltage interrupt 4. Executing a Debug mode entry command using the 56800E core JTAG interface 5. Any reset (POR, external, software, COP)
Standby	The OCCS generates the SYS_CLK_x2 clock at a reduced frequency (400kHz). The PLL and HS_PERF clocks are disabled and the high-speed peripheral option is not available. System and peripheral clocks operate at 200kHz.		The user configures the OCCS and SIM to select the relaxation oscillator clock source (PRECS), shut down the PLL (PLLDPD), put the relaxation oscillator in Standby mode (ROSB), and put the large regulator in Standby (LRSTDBY). The part is fully operational, but operating at a minimum frequency and power configuration. Recovery requires reversing the sequence used to enter this mode (allowing for PLL lock time).
Power-Down	Master clock generation in the OCCS is completely shut down. All system and peripheral clocks are disabled.		The user configures the OCCS and SIM to enter Standby mode as shown in the previous description, followed by powering down the oscillator (ROPD). The only possible recoveries from this mode are: 1. External reset 2. Power-on reset

The power modes provide additional means to disable clock domains, configure the voltage regulator, and configure clock generation to manage power utilization, as shown in [Table 6-3](#). Run, Wait, and Stop modes provide means of enabling/disabling the peripheral and/or core clocking as a group. Stop disable controls are provided for selected peripherals in the control register (SCI and TMR channels) so that these peripheral clocks can optionally continue to operate in Stop mode and generate interrupts which will return the part from Stop to Run mode. Standby mode provides normal operation but at very low speed and power

utilization. It is possible to invoke Stop or Wait mode while in Standby mode for even greater levels of power reduction. A 400kHz clock external clock can optionally be used in Standby mode to produce the required Standby 200kHz system bus rate. Power-down mode, which selects the ROOSC clock source but shuts it off, fully disables the part and minimizes its power utilization but is only recoverable via reset.

When the PLL is not selected and the system bus is operating at 200kHz or less, the large regulator can be put into its Standby mode (LRSTDBY) to reduce the power utilization of that regulator.

All peripherals, except the COP/watchdog timer, run at the IPBus clock (peripheral bus) frequency<sup>1</sup>, which is the same as the main processor frequency in this architecture. The COP timer runs at  $MSTR\_OSC / 1024$ . The maximum frequency of operation is  $SYS\_CLK = 32MHz$ . The only exception is the TMR and PWM, which can be configured to operate at three times the system bus rate using TCR and PCR controls, provided the PLL is active and selected.

## 6.6 Resets

The SIM supports four sources of reset, as shown in [Figure 6-15](#). The two asynchronous sources are the external reset pin and the Power-On Reset (POR). The two synchronous sources are the software reset, which is generated within the SIM itself by writing the SIM\_CTRL register in [Section 6.3.1](#), and the COP reset. The SIM uses these to generate resets for the internal logic. These are outlined in [Table 6-4](#). The first column lists the four primary resets which are calculated. The JTAG circuitry is reset by the Power-On Reset. Columns two through five indicate which reset sources trigger these reset signals. The last column provides additional detail.

**Table 6-4 Primary System Resets**

Reset Signal	Reset Sources				Comments
	POR	External	Software	COP	
EXTENDED_POR	X				Stretched version of $\overline{POR}$ . Relevant 64 Relaxation Oscillator Clock cycles after $\overline{POR}$ deasserts.
CLKGEN_RST	X	X	X	X	Released 32 Relaxation Oscillator Clock cycles after all reset sources have released.
PERIP_RST	X	X	X	X	Releases 32 Relaxation Oscillator Clock cycles after the $\overline{CLKGEN\_RST}$ is released.
CORE_RST	X	X	X	X	Releases 32 SYS_CLK periods after $\overline{PERIP\_RST}$ is released.

1. The TMR and PWM modules can be operated at three times the IPBus clock frequency.

**Figure 6-15** provides a graphic illustration of the details in **Table 6-4**. Note that the POR\_Delay blocks use the Relaxation Oscillator Clock as their time base since other system clocks are inactive during this phase of reset.

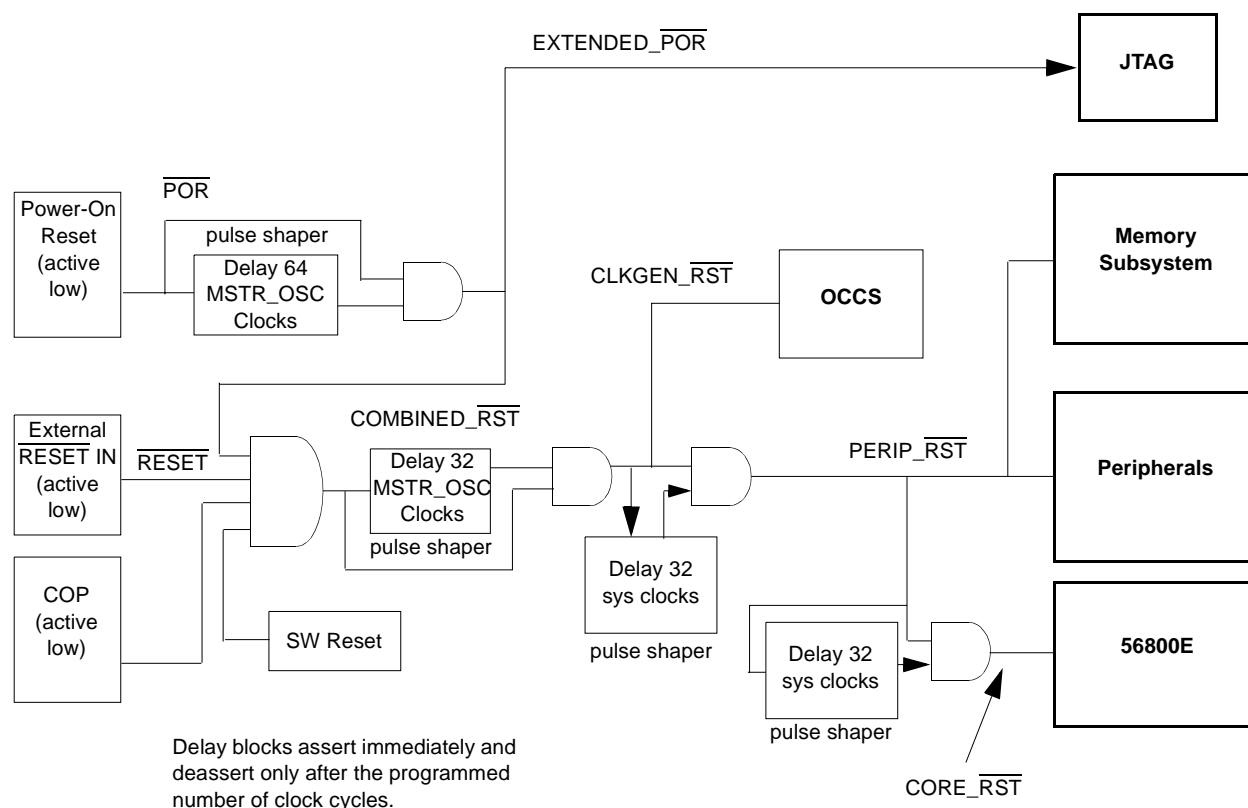

**Figure 6-15 Sources of RESET Functional Diagram (Test modes not included)**

POR resets are extended 64 MSTR\_OSC clocks to stabilize the power supply. All resets are subsequently extended for an additional 32 MSTR\_OSC clocks and 64 system clocks as the various internal reset controls are released. Given the normal relaxation oscillator rate of 8MHz, the duration of a POR reset from when power comes on to when code is running is 28 $\mu$ S. An external reset generation chip may also be used. Resets may be asserted asynchronously, but they are always released internally on a rising edge of the system clock.

## 6.7 Clocks

The memory, peripheral and core clocks all operate at the same frequency (32MHz max) with the exception of the TMR and PWM peripheral clocks, which have the option (using TCR and PCR) to operate three times faster. The SIM is responsible for stalling individual clocks as a response to various hold-off requests, low power modes, and other configuration parameters. The SIM has access to the following signals from the OCCS module:

MSTR_OSC	This comes from the input clock source mux of the OCCS. It is the output of the relaxation oscillator or the external clock source, depending on PRECS. It is not guaranteed to be at 50% duty cycle (+ or - 10% can probably be assumed for design purposes). This clock runs continuously, even during reset and is used for reset generation.
HS_PERF	The PLL multiplies the MSTR_OSC by 24, to a maximum of 192MHz. The ZSRC field in OCCS selects the active source to be the PLL. This is divided by 2 and postscaled to produce this maximum 96MHz clock. It is used without further division to produce the high-speed (3x system bus rate) variants of the TMR and PWM peripheral clocks. This clock is disabled when ZSRC is selecting MSTR_OSC.
SYS_CLK_x2	The PLL can multiply the MSTR_OSC by 24, to a maximum of 192MHz. When the PLL is selected by the OCCS ZSRC field, the PLL is divided by three and postscaled to produce this maximum 64MHz clock. When MSTR_OSC is selected by the OCCS ZSRC field, MSTR_OSC feeds SYS_CLK_x2 directly. The SIM takes this clock and divides it by two to generate all the normal (1x system bus rate) peripheral and system clocks.

While the SIM generates the ADC peripheral clock in the same way it generates all other peripheral clocks, the ADC standby and conversion clocks are generated by a direct interface between the ADC and the OCCS module.

**Figure 6-16** illustrates clock relationships to one another and to the various resets as the device comes out of reset.  $\overline{RST}$  is assumed to be the logical AND of all active-low system resets (for example, POR, external reset, COP and Software reset). In the 56F8014 architecture, this signal will be stretched by the SIM for a period of time (up to 96 MSTR\_OSC clock cycles, depending upon the status of the POR) to create the clock generation reset signal (CLKGEN\_ $\overline{RST}$ ). The SIM should deassert CLKGEN\_ $\overline{RST}$  synchronously with the negative edge of OSC\_CLK in order to avoid skew problems. CLKGEN\_ $\overline{RST}$  is delayed 32 SYS\_CLK cycles to create the peripheral reset signal (PERIP\_ $\overline{RST}$ ). PERIP\_ $\overline{RST}$  is then delayed by 32 SYS\_CLK cycles to create CORE\_ $\overline{RST}$ . Both PERIP\_ $\overline{RST}$  and CORE\_ $\overline{RST}$  should be released on the negative edge of SYS\_CLK\_D as shown. This phased releasing of system resets is necessary to give some peripherals (for example, the Flash interface unit) set-up time prior to the 56800E core becoming active.

Maximum Delay = 64 MSTR\_OSC cycles for POR reset extension and 32 MSTR\_OSC cycles for combined reset extension

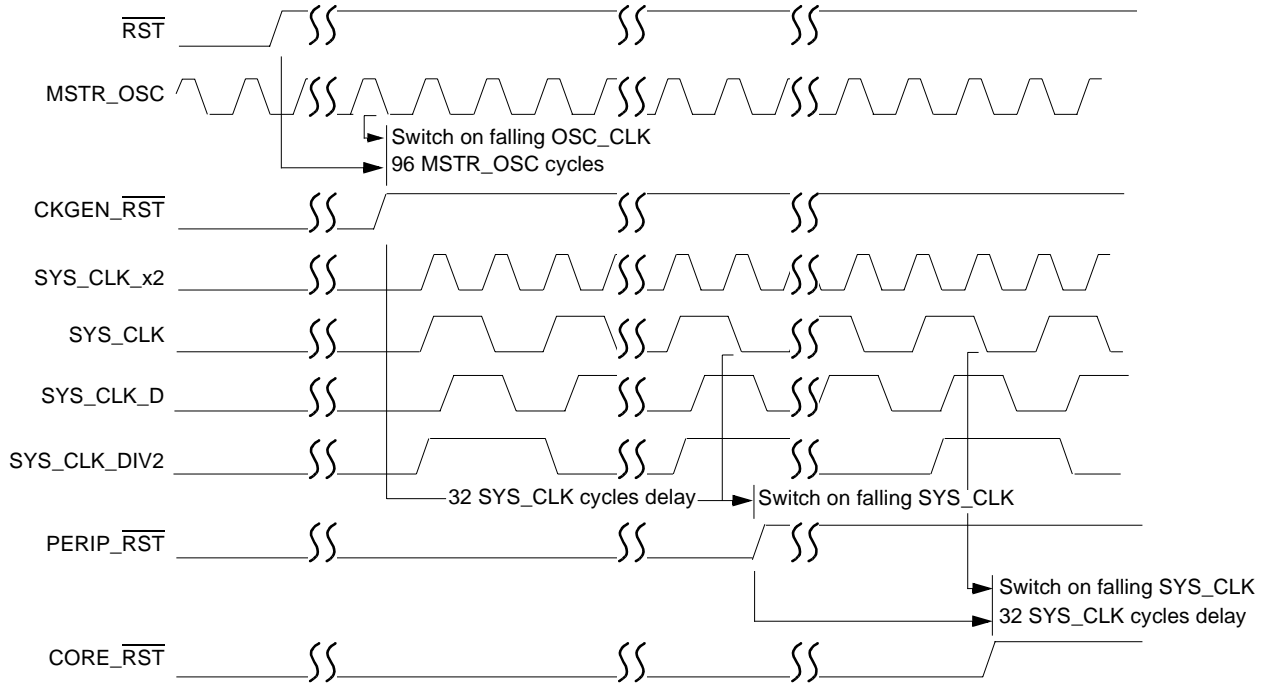

**Figure 6-16 Timing Relationships of Reset Signal to Clocks**

## 6.8 Interrupts

The SIM generates no interrupts.

## Part 7 Security Features

The 56F8014 offers security features intended to prevent unauthorized users from reading the contents of the Flash Memory (FM) array. The 56F8014's Flash security consists of several hardware interlocks that prevent unauthorized users from gaining access to the Flash array.

Note, however, that part of the security must lie with the user's code. An extreme example would be user's code that includes a subroutine to read and transfer the contents of the internal program to SCI, SPI or another peripheral, as this code would defeat the purpose of security. At the same time, the user may also wish to put a "backdoor" in his program. As an example, the user downloads a security key through the SCI, allowing access to a programming routine that updates parameters stored in another section of the Flash.

### 7.1 Operation with Security Enabled

Once the user has programmed the Flash with his application code, the 56F8014 can be secured by programming the security bytes located in the FM configuration field, which are located at the last 9 words of Program Flash. These non-volatile bytes will keep the part secured through reset and through power-down of the device. Only two bytes within this field are used to enable or disable security. Refer to the Flash Memory chapter in the **56F8000 Peripheral Reference Manual** for the state of the security bytes and the resulting state of security. When Flash security mode is enabled in accordance with the method described in the Flash Memory module chapter, the 56F8014 will disable the core EOnCE debug capabilities. Normal program execution is otherwise unaffected.

### 7.2 Flash Access Lock and Unlock Mechanisms

The 56F8014 has several operating functional and debug modes. Effective Flash security must address operating mode selection and anticipate modes in which the on-chip Flash can be read without explicit user permission.

#### 7.2.1 Disabling EOnCE Access

On-chip Flash can be read by issuing commands across the EOnCE port, which is the debug interface for the 56800E CPU. The TCLK, TMS, TDO, and TDI pins comprise a JTAG interface onto which the EOnCE port functionality is mapped. When the 56F8014 boots, the chip-level JTAG TAP (Test Access Port) is active and provides the chip's boundary scan capability and access to the ID register, but proper implementation of Flash security will block any attempt to access the internal Flash memory via the EOnCE port when security is enabled.

#### 7.2.2 Flash Lockout Recovery Using JTAG

If a user inadvertently enables security on the 56F8014, the only lockout recovery mechanism is the complete erasure of the internal Flash contents, including the configuration field, and thus disables security (the protection register is cleared). This does not compromise security, as the entire contents of the user's secured code stored in Flash are erased before security is disabled on the 56F8014 on the next reset or power-up sequence.

To start the lockout recovery sequence, the JTAG public instruction (LOCKOUT\_RECOVERY) must first be shifted into the chip-level TAP controller's instruction register. Once the LOCKOUT\_RECOVERY instruction has been shifted into the instruction register, the clock divider value must be shifted into the corresponding 7-bit data register. After the data register has been updated, the user must transition the TAP controller into the RUN-TEST/IDLE state for the lockout sequence to commence. The controller must remain in this state until the erase sequence has completed. Refer to the **56F8000 Peripheral Reference Manual** for more details, or contact Freescale.

**Note:** Once the lockout recovery sequence has completed, the user must reset both the JTAG TAP controller (by advancing the TAP state machine to the reset state) and the 56F8014 (by asserting external chip reset) to return to normal unsecured operation.

### 7.2.3 Flash Lockout Recovery using CodeWarrior

CodeWarrior can unlock a device using the command sequence described in Section 7.2.2 by selecting the *Debug* menu, then selecting *DSP56800E*, followed by *Unlock Flash*.

Another mechanism is also built into CodeWarrior using the device's memory configuration file. The command "*Unlock\_Flash\_on\_Connect1*" in the *.cfg* file accomplishes the same task as using the *Debug* menu.

### 7.2.4 Product Analysis

The recommended method of unsecuring a programmed 56F8014 for product analysis of field failures is via the backdoor key access. The customer would need to supply Technical Support with the backdoor key and the protocol to access the backdoor routine in the Flash. Additionally, the KEYEN bit that allows backdoor key access must be set.

An alternative method for performing analysis on a secured microcontroller would be to mass-erase and reprogram the Flash with the original code, but modify the security bytes.

To insure that a customer does not inadvertently lock himself out of the 56F8014 during programming, it is recommended that the user program the backdoor access key first, the application code second and the security bytes within the FM configuration field last.

## Part 8 General Purpose Input/Output (GPIO)

### 8.1 Introduction

This section is intended to supplement the GPIO information found in the **56F8000 Peripheral Reference Manual** and contains only chip-specific information. This information supercedes the generic information in the **56F8000 Peripheral Reference Manual**.

### 8.2 Configuration

There are four GPIO ports defined on the 56F8014. The width of each port, the associated peripheral and reset functions are shown in **Table 8-1**. The specific mapping of GPIO port pins is shown in **Table 8-2**.

**Table 8-1 GPIO Ports Configuration**

GPIO Port	Available Pins in 56F8014	Peripheral Function	Reset Function
A	6	PWM, Reset	GPIO, except GPIOA7
B	8	SPI, SCI, Timer	GPIO
C	8	XTAL, EXTAL, CAN, TMRC	Analog
D	4	JTAG	JTAG

**Table 8-2 GPIO External Signals Map**  
Pins in shaded rows are not available in 56F8014

GPIO Function	Peripheral Function	LQFP Package Pin	Notes
GPIOA0	PWM0	28	Defaults to A0
GPIOA1	PWM1	27	Defaults to A1
GPIOA2	PWM2	23	Defaults to A2
GPIOA3	PWM3		Not bonded out in 56F8014 Defaults to A3
GPIOA4	PWM4 / FAULT1 / T2	22	SIM register SIM_GPS is used to select between PWM4, FAULT1, and T2 Defaults to A4
GPIOA5	PWM5 / FAULT2 / T3	20	SIM register SIM_GPS is used to select between PWM5, FAULT2, and T3 Defaults to A5
GPIOA6	FAULT0		Not bonded out in 56F8014 Defaults to A6
GPIOA7	$\overline{\text{RESET}}$	16	Defaults to $\overline{\text{RESET}}$
GPIOB0	SCLK / SCL	21	SIM register SIM_GPS is used to select between SCLK and SCL Defaults to B0
GPIOB1	$\overline{\text{SS}}$ / SDA	1	SIM register SIM_GPS is used to select between $\overline{\text{SS}}$ and SDA Defaults to B1
GPIOB2	MISO / T2	18	SIM register SIM_GPS is used to select between MISO and T2 Defaults to B2
GPIOB3	MOSI / T3	17	SIM register SIM_GPS is used to select between MOSI and T3 Defaults to B3
GPIOB4	T0 / CLKO	19	SIM register SIM_GPS is used to select between T0 and CLKO Defaults to B4
GPIOB5	T1 / FAULT3	3	SIM register SIM_GPS is used to select between T1 and FAULT3 Defaults to B5
GPIOB6	RXD / SDA / CLKIN	32	SIM register SIM_GPS is used to select between RXD and SDA. CLKIN functionality is enabled using the PLL Control Register within the OCCS block. Defaults to B6

**Table 8-2 GPIO External Signals Map (Continued)**  
Pins in shaded rows are not available in 56F8014

GPIO Function	Peripheral Function	LQFP Package Pin	Notes
GPIOB7	TXD / SCL	2	SIM register SIM_GPS is used to select between TXD and SCL Defaults to B7
GPIOC0	ANA0	13	Defaults to ANA0
GPIOC1	ANA1	12	Defaults to ANA1
GPIOC2	ANA2 / V <sub>REFH</sub>	11	Defaults to ANA2
GPIOC3	ANA3	10	Defaults to ANA3
GPIOC4	ANB0	4	Defaults to ANB0
GPIOC5	ANB1	5	Defaults to ANB1
GPIOC6	ANB2 / V <sub>REFL</sub>	6	Defaults to ANB2
GPIOC7	ANB3	7	Defaults to ANB3
GPIOD0	TDI	29	Defaults to TDI
GPIOD1	TDO	31	Defaults to TDO
GPIOD2	TCK	15	Defaults to TCK
GPIOD3	TMS	30	Defaults to TMS

### 8.3 Reset Values

Tables 4-16 through 4-19 detail registers for the 56F8014; Figures 8-1 through 8-4 summarize register maps and reset values.

Add. Offset	Register Acronym		15	14	13	12	11	10	9	8	7	6	5	4	3	2	1	0
\$0	GPIOA_PUPEN	R	0	0	0	0	0	0	0	0	PU							
		W																
		RS	0	0	0	0	0	0	0	0	1	1	1	1	1	1	1	1
\$1	GPIOA_DATA	R	0	0	0	0	0	0	0	0	D							
		W																
		RS	0	0	0	0	0	0	0	0	0	1	1	1	1	1	1	1
\$2	GPIOA_DIR	R	0	0	0	0	0	0	0	0	DD							
		W																
		RS	0	0	0	0	0	0	0	0	0	0	0	0	0	0	0	0
\$3	GPIOA_PEREN	R	0	0	0	0	0	0	0	0	PE							
		W																
		RS	0	0	0	0	0	0	0	0	1	0	0	0	0	0	0	0
\$4	GPIOA_IASSRT	R	0	0	0	0	0	0	0	0	IA							
		W																
		RS	0	0	0	0	0	0	0	0	0	0	0	0	0	0	0	0
\$5	GPIOA_IEN	R	0	0	0	0	0	0	0	0	IEN							
		W																
		RS	0	0	0	0	0	0	0	0	0	0	0	0	0	0	0	0
\$6	GPIOA_IEPOL	R	0	0	0	0	0	0	0	0	IEPOL							
		W																
		RS	0	0	0	0	0	0	0	0	0	0	0	0	0	0	0	0
\$7	GPIOA_IPEND	R	0	0	0	0	0	0	0	0	IPR							
		W																
		RS	0	0	0	0	0	0	0	0	0	0	0	0	0	0	0	0
\$8	GPIOA_IEDGE	R	0	0	0	0	0	0	0	0	IES							
		W																
		RS	0	0	0	0	0	0	0	0	0	0	0	0	0	0	0	0
\$9	GPIOA_PPOUTM	R	0	0	0	0	0	0	0	0	OEN							
		W																
		RS	0	0	0	0	0	0	0	0	1	1	1	1	1	1	1	1
\$A	GPIOA_RDATA	R	0	0	0	0	0	0	0	0	RAW DATA							
		W																
		RS	X	X	X	X	X	X	X	X	X	X	X	X	X	X	X	X
\$B	GPIOA_DRIVE	R	0	0	0	0	0	0	0	0	DRIVE							
		W																
		RS	0	0	0	0	0	0	0	0	0	0	0	0	0	0	0	0

R	0	Read as 0
W		Reserved
RS		Reset

Figure 8-1 GPIOA Register Map Summary

Addr. Offset	Register Acronym		15	14	13	12	11	10	9	8	7	6	5	4	3	2	1	0	
\$0	GPIOB_PUPEN	R	0	0	0	0	0	0	0	0	PU								
		W																	
		RS	0	0	0	0	0	0	0	0	0	1	1	1	1	1	1	1	1
\$1	GPIOB_DATA	R	0	0	0	0	0	0	0	0	D								
		W																	
		RS	0	0	0	0	0	0	0	0	0	1	1	1	1	1	1	1	1
\$2	GPIOB_DDIRE	R	0	0	0	0	0	0	0	0	DD								
		W																	
		RS	0	0	0	0	0	0	0	0	0	0	0	0	0	0	0	0	0
\$3	GPIOB_PEREN	R	0	0	0	0	0	0	0	0	PE								
		W																	
		RS	0	0	0	0	0	0	0	0	0	0	0	0	0	0	0	0	0
\$4	GPIOB_IASSRT	R	0	0	0	0	0	0	0	0	IA								
		W																	
		RS	0	0	0	0	0	0	0	0	0	0	0	0	0	0	0	0	0
\$5	GPIOB_IEN	R	0	0	0	0	0	0	0	0	IEN								
		W																	
		RS	0	0	0	0	0	0	0	0	0	0	0	0	0	0	0	0	0
\$6	GPIOB_IEPOL	R	0	0	0	0	0	0	0	0	IEPOL								
		W																	
		RS	0	0	0	0	0	0	0	0	0	0	0	0	0	0	0	0	0
\$7	GPIOB_IPEND	R	0	0	0	0	0	0	0	0	IPR								
		W																	
		RS	0	0	0	0	0	0	0	0	0	0	0	0	0	0	0	0	0
\$8	GPIOB_IEDGE	R	0	0	0	0	0	0	0	0	IES								
		W																	
		RS	0	0	0	0	0	0	0	0	0	0	0	0	0	0	0	0	0
\$9	GPIOB_PPOUTM	R	0	0	0	0	0	0	0	0	OEN								
		W																	
		RS	0	0	0	0	0	0	0	0	0	1	1	1	1	1	1	1	1
\$A	GPIOB_RDATA	R	0	0	0	0	0	0	0	0	RAW DATA								
		W																	
		RS	X	X	X	X	X	X	X	X	X	X	X	X	X	X	X	X	X
\$B	GPIOB_DRIVE	R	0	0	0	0	0	0	0	0	DRIVE								
		W																	
		RS	0	0	0	0	0	0	0	0	0	0	0	0	0	0	0	0	0

R	0	Read as 0
W		Reserved
RS		Reset

**Figure 8-2 GPIOB Register Map Summary**

Add. Offset	Register Acronym		15	14	13	12	11	10	9	8	7	6	5	4	3	2	1	0
\$0	GPIOC_PUPEN	R	0	0	0	0	0	0	0	0	PU							
		W																
		RS	0	0	0	0	0	0	0	0	1	1	1	1	1	1	1	1
\$1	GPIOC_DATA	R	0	0	0	0	0	0	0	0	D							
		W																
		RS	0	0	0	0	0	0	0	0	0	0	0	0	0	0	0	0
\$2	GPIOC_DIR	R	0	0	0	0	0	0	0	0	DD							
		W																
		RS	0	0	0	0	0	0	0	0	0	0	0	0	0	0	0	0
\$3	GPIOC_PEREN	R	0	0	0	0	0	0	0	0	PE							
		W																
		RS	0	0	0	0	0	0	0	0	1	1	1	1	1	1	1	1
\$4	GPIOC_IASSRT	R	0	0	0	0	0	0	0	0	IA							
		W																
		RS	0	0	0	0	0	0	0	0	0	0	0	0	0	0	0	0
\$5	GPIOC_IEN	R	0	0	0	0	0	0	0	0	IEN							
		W																
		RS	0	0	0	0	0	0	0	0	0	0	0	0	0	0	0	0
\$6	GPIOC_IEPOL	R	0	0	0	0	0	0	0	0	IEPOL							
		W																
		RS	0	0	0	0	0	0	0	0	0	0	0	0	0	0	0	0
\$7	GPIOC_IPEND	R	0	0	0	0	0	0	0	0	IPR							
		W																
		RS	0	0	0	0	0	0	0	0	0	0	0	0	0	0	0	0
\$8	GPIOC_IEDGE	R	0	0	0	0	0	0	0	0	IES							
		W																
		RS	0	0	0	0	0	0	0	0	0	0	0	0	0	0	0	0
\$9	GPIOC_PPOUTM	R	0	0	0	0	0	0	0	0	OEN							
		W																
		RS	0	0	0	0	0	0	0	0	1	1	1	1	1	1	1	1
\$A	GPIOC_RDATA	R	0	0	0	0	0	0	0	0	RAW DATA							
		W																
		RS	X	X	X	X	X	X	X	X	X	X	X	X	X	X	X	X
\$B	GPIOC_DRIVE	R	0	0	0	0	0	0	0	0	DRIVE							
		W																
		RS	0	0	0	0	0	0	0	0	0	0	0	0	0	0	0	0

R	0	Read as 0
W		Reserved
RS		Reset

Figure 8-3 GPIOC Register Map Summary

Add. Offset	Register Acronym		15	14	13	12	11	10	9	8	7	6	5	4	3	2	1	0
\$0	GPIOD_PUPEN	R	0	0	0	0	0	0	0	0	0	0	0	0	PU			
		W																
		RS	0	0	0	0	0	0	0	0	0	0	0	0	1	1	1	1
\$1	GPIOD_DATA	R	0	0	0	0	0	0	0	0	0	0	0	D				
		W																
		RS	0	0	0	0	0	0	0	0	0	0	0	0	0	0	0	0
\$2	GPIOD_DDIR	R	0	0	0	0	0	0	0	0	0	0	0	DD				
		W																
		RS	0	0	0	0	0	0	0	0	0	0	0	0	0	0	0	0
\$3	GPIOD_PEREN	R	0	0	0	0	0	0	0	0	0	0	0	PE				
		W																
		RS	0	0	0	0	0	0	0	0	0	0	0	0	1	1	1	1
\$4	GPIOD_IASSRT	R	0	0	0	0	0	0	0	0	0	0	0	IA				
		W																
		RS	0	0	0	0	0	0	0	0	0	0	0	0	0	0	0	0
\$5	GPIOD_IEN	R	0	0	0	0	0	0	0	0	0	0	0	IEN				
		W																
		RS	0	0	0	0	0	0	0	0	0	0	0	0	0	0	0	0
\$6	GPIOD_IEPOL	R	0	0	0	0	0	0	0	0	0	0	0	IEPOL				
		W																
		RS	0	0	0	0	0	0	0	0	0	0	0	0	0	0	0	0
\$7	GPIOD_IPEND	R	0	0	0	0	0	0	0	0	0	0	0	IPR				
		W																
		RS	0	0	0	0	0	0	0	0	0	0	0	0	0	0	0	0
\$8	GPIOD_IEDGE	R	0	0	0	0	0	0	0	0	0	0	0	IES				
		W																
		RS	0	0	0	0	0	0	0	0	0	0	0	0	0	0	0	0
\$9	GPIOD_PPOUTM	R	0	0	0	0	0	0	0	0	0	0	0	OEN				
		W																
		RS	0	0	0	0	0	0	0	0	0	0	0	0	1	1	1	1
\$A	GPIOD_RDATA	R	0	0	0	0	0	0	0	0	0	0	0	RAW DATA				
		W																
		RS	X	X	X	X	X	X	X	X	X	X	X	X	X	X	X	X
\$B	GPIOD_DRIVE	R	0	0	0	0	0	0	0	0	0	0	0	DRIVE				
		W																
		RS	0	0	0	0	0	0	0	0	0	0	0	0	0	0	0	0

R	0	Read as 0
W		Reserved
RS		Reset

**Figure 8-4 GPIOD Register Map Summary**

## Part 9 Joint Test Action Group (JTAG)

### 9.1 56F8014 Information

Please contact your Freescale sales representative or authorized distributor for device/package-specific BSDL information.

The  $\overline{\text{TRST}}$  pin is not available in this package. The pin is tied to  $V_{\text{DD}}$  in the package.

The JTAG state machine is reset during POR and can also be reset via a soft reset by holding TMS high for five rising edges of TCK, as described in the **56F8000 Peripheral User Manual**.

## Part 10 Specifications

### 10.1 General Characteristics

The 56F8014 is fabricated in high-density CMOS with 5V-tolerant TTL-compatible digital inputs. The term “5V-tolerant” refers to the capability of an I/O pin, built on a 3.3V-compatible process technology, to withstand a voltage up to 5.5V without damaging the device. Many systems have a mixture of devices designed for 3.3V and 5V power supplies. In such systems, a bus may carry both 3.3V- and 5V-compatible I/O voltage levels (a standard 3.3V I/O is designed to receive a maximum voltage of  $3.3\text{V} \pm 10\%$  during normal operation without causing damage). This 5V-tolerant capability therefore offers the power savings of 3.3V I/O levels, combined with the ability to receive 5V levels without damage.

Absolute maximum ratings in [Table 10-1](#) are stress ratings only, and functional operation at the maximum is not guaranteed. Stress beyond these ratings may affect device reliability or cause permanent damage to the device.

Unless otherwise stated, all specifications within this chapter apply over the temperature range of  $-40^{\circ}\text{C}$  to  $105^{\circ}\text{C}$  ambient temperature over the following supply ranges:

$$V_{\text{SS}} = V_{\text{SSA}} = 0\text{V}, V_{\text{DD}} = V_{\text{DDA}} = 3.0\text{--}3.6\text{V}, \text{CL} \leq 50\text{pF}, f_{\text{OP}} = 32\text{MHz}$$

#### CAUTION

**This device contains protective circuitry to guard against damage due to high static voltage or electrical fields. However, normal precautions are advised to avoid application of any voltages higher than maximum-rated voltages to this high-impedance circuit. Reliability of operation is enhanced if unused inputs are tied to an appropriate voltage level.**

**Table 10-1 Absolute Maximum Ratings**

( $V_{SS} = 0V$ ,  $V_{SSA} = 0V$ )

Characteristic	Symbol	Notes	Min	Max	Unit
Supply Voltage Range	$V_{DD}$		-0.3	4.0	V
Analog Supply Voltage Range	$V_{DDA}$		-0.3	4.0	V
ADC High Voltage Reference	$V_{REFH}$		-0.3	4.0	V
Input Voltage Range (Digital inputs)	$V_{IN}$	Pin Groups 1, 2	-0.3	6.0	V
Input Voltage Range (ADC inputs)	$V_{INA}$	Pin Group 3	-0.3	4.0	V
Input clamp current, per pin ( $V_{IN} < 0$ ) <sup>1</sup>	$V_{IC}$		-	-20	mA
Output clamp current, per pin ( $V_O < 0$ ) <sup>1</sup>	$V_{OC}$		-	-20	mA
Output Voltage Range (Normal Push-Pull mode)	$V_{OUT}$	Pin Group 1	-0.3	4.0	V
Output Voltage Range (Open Drain mode)	$V_{OUTOD}$	Pin Groups 1, 2	-0.3	6.0	V
Ambient Temperature	$T_A$		-40	105	°C
Storage Temperature Range	$T_S$		-55	150	°C

1. Continuous input current per pin is -2 mA

**Default Mode**

Pin Group 1: GPIOA, TDI, TDO, TMS, TCK

Pin Group 2:  $\overline{RESET}$ , GPIOA7

Pin Group 3: ADC analog inputs

**10.1.1 ElectroStatic Discharge (ESD) Model**

**Table 10-2 56F8014 ESD Protection**

Characteristic	Min	Typ	Max	Unit
ESD for Human Body Model (HBM)	2000	—	—	V
ESD for Machine Model (MM)	200	—	—	V
ESD for Charge Device Model (CDM)	750	—	—	V

**Table 10-3 LQFP Package Thermal Characteristics<sup>6</sup>**

Characteristic	Comments	Symbol	Value (LQFP)	Unit	Notes
Junction to ambient Natural convection	Single layer board (1s)	$R_{\theta JA}$	74	°C/W	1,2
Junction to ambient Natural convection	Four layer board (2s2p)	$R_{\theta JMA}$	50	°C/W	1,3
Junction to ambient (@200 ft/min)	Single layer board (1s)	$R_{\theta JMA}$	67	°C/W	1,3
Junction to ambient (@200 ft/min)	Four layer board (2s2p)	$R_{\theta JMA}$	46	°C/W	1,3
Junction to board		$R_{\theta JB}$	23	°C/W	4
Junction to case		$R_{\theta JC}$	20	°C/W	5
Junction to package top	Natural Convection	$\Psi_{JT}$	4	°C/W	6

1. Junction temperature is a function of die size, on-chip power dissipation, package thermal resistance, mounting site (board) temperature, ambient temperature, air flow, power dissipation of other components on the board, and board thermal resistance.
2. Per SEMI G38-87 and JEDEC JESD51-2 with the single layer board horizontal.
3. Per JEDEC JESD51-6 with the board horizontal.
4. Thermal resistance between the die and the printed circuit board per JEDEC JESD51-8. Board temperature is measured on the top surface of the board near the package.
5. Thermal resistance between the die and the case top surface as measured by the cold plate method (MIL SPEC-883 Method 1012.1).
6. Thermal characterization parameter indicating the temperature difference between package top and the junction temperature per JEDEC JESD51-2. When Greek letters are not available, the thermal characterization parameter is written as Psi-JT.
7. See [Section 12.1](#) for more details on thermal design considerations.

**Table 10-4 Recommended Operating Conditions**

( $V_{REFL} = 0V$ ,  $V_{SSA} = 0V$ ,  $V_{SS} = 0V$ )

Characteristic	Symbol	Notes	Min	Typ	Max	Unit
Supply voltage	$V_{DD}$		3	3.3	3.6	V
ADC Supply voltage	$V_{DDA}$		3	3.3	3.6	V
ADC High Voltage Reference	$V_{REFH}$		3	—	$V_{DDA}$	V
Device Clock Frequency Using relaxation oscillator Using external clock source	FSYSCLK		8 0	—	32 32	MHz
Input Voltage High (digital inputs)	$V_{IH}$	Pin Groups 1, 2	2	—	5.5	V
Input Voltage Low (digital inputs)	$V_{IL}$	Pin Groups 1, 2	-0.3	—	0.8	V
Output Source Current High (at $V_{OH}$ min.) When programmed for low drive strength When programmed for high drive strength	$I_{OH}$	Pin Group 1 Pin Group 1	— —	— —	-4 -8	mA
Output Source Current Low (at $V_{OL}$ max.) When programmed for low drive strength When programmed for high drive strength	$I_{OL}$	Pin Groups 1, 2 Pin Groups 1, 2	— —	— —	4 8	mA
Ambient Operating Temperature	$T_A$		-40	—	105 - ( $R_{\theta JA} \times P_D$ )	°C
Flash Endurance (Program Erase Cycles)	$N_F$	$T_A = -40^\circ\text{C}$ to $105^\circ\text{C}$	10,000	—	—	Cycles
Flash Data Retention	$T_R$	$T_J \leq 70^\circ\text{C}$ avg	15	—	—	Years

**Note:** Total chip source or sink current cannot exceed 50mA

**Default Mode**

Pin Group 1: GPIO, TDI, TDO, TMS, TCK

Pin Group 2:  $\overline{\text{RESET}}$ , GPIOA7

Pin Group 3: ADC analog inputs

## 10.2 DC Electrical Characteristics

**Table 10-5 DC Electrical Characteristics**  
At Recommended Operating Conditions

Characteristic	Symbol	Notes	Min	Typ	Max	Unit	Test Conditions
Output Voltage High	$V_{OH}$	Pin Group 1	2.4	—	—	V	$I_{OH} = I_{OHmax}$
Output Voltage Low	$V_{OL}$	Pin Groups 1, 2	—	—	0.4	V	$I_{OL} = I_{OLmax}$
Digital Input Current High (a) pull-up enabled or disabled	$I_{IH}$	Pin Groups 1, 2	—	0	+/- 2.5	$\mu A$	$V_{IN} = 2.4V$ to 5.5V
ADC Input Current High	$I_{IHA}$	Pin Group 3	—	0	+/- 10	$\mu A$	$V_{INA} = V_{DDA}$
Digital Input Current Low (a) pull-up enabled pull-up disabled	$I_{IL}$	Pin Groups 1, 2	-15 —	-30	-60 +/- 2.5	$\mu A$	$V_{IN} = 0V$
ADC Input Current Low	$I_{ILA}$	Pin Group 3	—	0	+/- 10	$\mu A$	$V_{INA} = 0V$
Output Current High Impedance State (a)	$I_{OZ}$	Pin Groups 1, 2	—	0	+/- 2.5	$\mu A$	$V_{OUT} = 2.4V$ to 5.5V or 0V
Schmitt Trigger Input Hysteresis	$V_{HYS}$	Pin Groups 1, 2	—	0.35	—	V	—
Input Capacitance	$C_{IN}$		—	10	—	pF	—
Output Capacitance	$C_{OUT}$		—	10	—	pF	—

(a) See [Figure 10-1](#)

### Default Mode

Pin Group 1: GPIO, TDI, TDO, TMS, TCK

Pin Group 2:  $\overline{RESET}$ , GPIOA7

Pin Group 3: ADC analog inputs

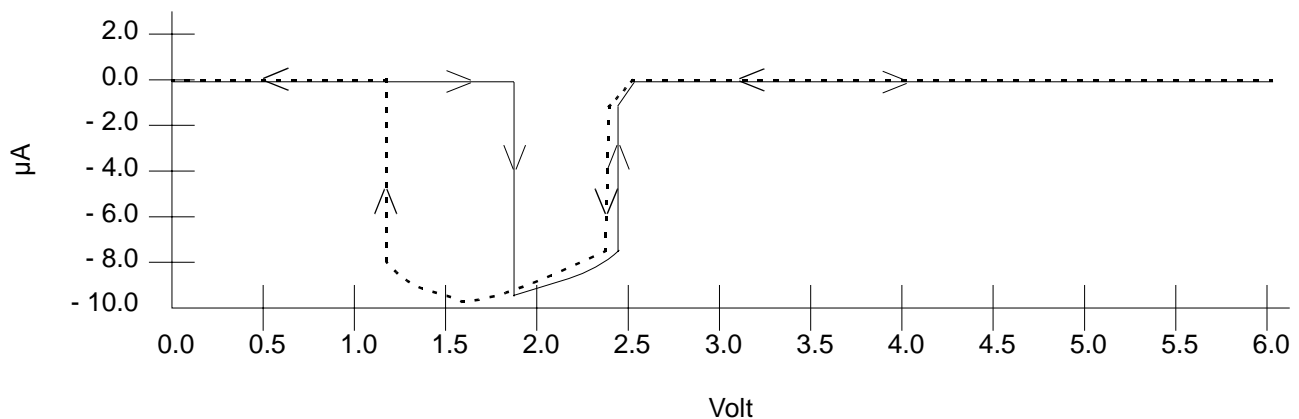

**Figure 10-1  $I_{IN}/I_{OZ}$  vs. Voltage (Typical)**

**Table 10-6 Current Consumption per Power Supply Pin (Typical)**

Mode	Conditions	I <sub>DD</sub> <sup>1</sup>	I <sub>DDA</sub>
RUN	32MHz Device Clock Relaxation Oscillator on PLL powered on Continuous MAC instructions with fetches from Program Flash All peripheral modules enabled. TMR and PWM using 1x Clock ADC powered on and clocked	42mA	13.5mA
WAIT	32MHz Device Clock Relaxation Oscillator on PLL powered on Core halted All Peripheral modules enabled. TMR and PWM using 1x Clock ADC powered off	17mA	0μA
STOP	8MHz Device Clock Relaxation Oscillator on PLL powered off All peripheral module and core clocks are off ADC powered off	5mA	0μA
STANDBY	100KHz Device Clock Relaxation Oscillator in Standby mode PLL powered off All peripheral module and core clocks are off ADC in Standby mode Voltage Regulator in Standby mode	210μA	400μA
STANDBY > STOP	100KHz Device Clock Relaxation Oscillator in Standby mode PLL powered off All peripheral module and core clocks are off ADC powered off Voltage regulator in Standby mode	210μA	0μA
POWERDOWN	Device Clock is off Relaxation Oscillator powered off PLL powered off All peripheral module and core clocks are off ADC powered off Voltage Regulator in Standby mode	160μA	0μA

1. No Output Switching  
All ports configured as inputs  
All inputs Low  
No DC Loads

**Table 10-7 Power-On Reset Low-Voltage Parameters**

Characteristic	Symbol	Min	Typ	Max	Unit
Low-Voltage Interrupt for 3.3V supply <sup>1</sup>	$V_{E13.3}$	2.65	2.7	—	V
Low-Voltage Interrupt for 2.5V supply <sup>2</sup>	$V_{E12.5}$	2.05	2.15	—	V
Low-Voltage Interrupt Recovery Hysteresis	$V_{EIH}$	—	50	—	mV
Power-On Reset <sup>3</sup>	POR	—	1.8	1.9	V

1. When  $V_{DD}$  drops below  $V_{E13.3}$  maximum value, an interrupt is generated.
2. When  $V_{DD}$  drops below  $V_{E12.5}$  maximum value, an interrupt is generated.
3. Power-On Reset occurs whenever the internally regulated 2.5V digital supply drops below 1.8V. While power is ramping up, this signal remains active for as long as the internal 2.5V is below 2.15V or the 3.3V I/O voltage is below 2.7V, no matter how long the ramp-up rate is. The internally regulated voltage is typically 100mV less than  $V_{DD}$  during ramp-up until 2.5V is reached, at which time it self-regulates.

## 10.2.1 Voltage Regulator Specifications

The 56F8014 has two on-chip regulators. One supplies the PLL and relaxation oscillator. It has no external pins and therefore has no external characteristics which must be guaranteed (other than proper operation of the device). The second regulator supplies approximately 2.5V to the 56F8014's core logic. This regulator requires an external 4.4 $\mu$ F, or greater, capacitor for proper operation. Ceramic and tantalum capacitors tend to provide better performance tolerances. The output voltage can be measured directly on the  $V_{CAP}$  pin. The specifications for this regulator are shown in [Table 10-8](#).

**Table 10-8. Regulator Parameters**

Characteristic	Symbol	Min	Typical	Max	Unit
Input Voltage	$V_{IN}$	3.0	—	3.6	V
Output Voltage	$V_{OUT}$	2.25	2.5	2.75	V
Short Circuit Current	$I_{SS}$	—	450	650	mA
Short Circuit Tolerance (output shorted to ground)	$T_{RSC}$	—	—	30	Minutes

## 10.3 AC Electrical Characteristics

Tests are conducted using the input levels specified in [Table 10-5](#). Unless otherwise specified, propagation delays are measured from the 50% to the 50% point, and rise and fall times are measured between the 10% and 90% points, as shown in [Figure 10-2](#).

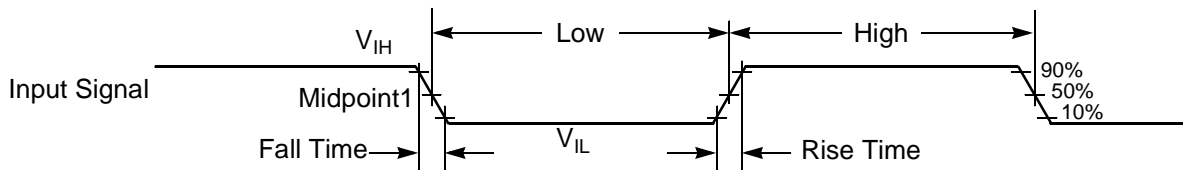

Note: The midpoint is  $V_{IL} + (V_{IH} - V_{IL})/2$ .

**Figure 10-2** Input Signal Measurement References

[Figure 10-3](#) shows the definitions of the following signal states:

- Active state, when a bus or signal is driven, and enters a low impedance state
- Tri-stated, when a bus or signal is placed in a high impedance state
- Data Valid state, when a signal level has reached  $V_{OL}$  or  $V_{OH}$
- Data Invalid state, when a signal level is in transition between  $V_{OL}$  and  $V_{OH}$

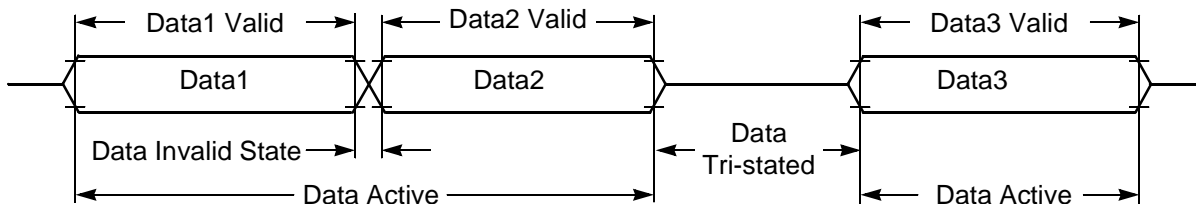

**Figure 10-3** Signal States

## 10.4 Flash Memory Characteristics

**Table 10-9** Flash Timing Parameters

Characteristic	Symbol	Min	Typ	Max	Unit
Program time <sup>1</sup>	T <sub>prog</sub>	20	—	40	μs
Erase time	T <sub>erase</sub>	20	—	—	ms
Mass erase time	T <sub>me</sub>	100	—	—	ms

1. There is additional overhead which is part of the programming sequence. See the [56F8000 Peripheral Reference Manual](#) for details. Program time is per 16-bit word in Flash memory.

## 10.5 External Clock Operation Timing

**Table 10-10 External Clock Operation Timing Requirements<sup>1</sup>**

Characteristic	Symbol	Min	Typ	Max	Unit
Frequency of operation (external clock driver) <sup>2</sup>	$f_{osc}$	4	8	8	MHz
Clock Pulse Width <sup>3</sup>	$t_{PW}$	6.25	—	—	ns
External Clock Input Rise Time <sup>4</sup>	$t_{rise}$	—	—	3	ns
External Clock Input Fall Time <sup>5</sup>	$t_{fall}$	—	—	3	ns

- Parameters listed are guaranteed by design.
- See [Figure 10-4](#) for details on using the recommended connection of an external clock driver.
- The high or low pulse width must be no smaller than 6.25ns or the chip may not function.
- External clock input rise time is measured from 10% to 90%.
- External clock input fall time is measured from 90% to 10%.

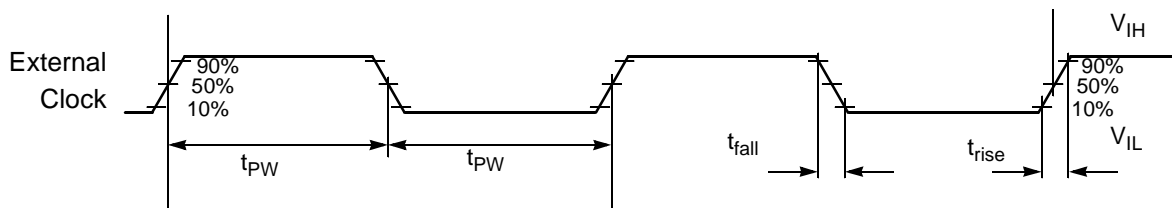

Note: The midpoint is  $V_{IL} + (V_{IH} - V_{IL})/2$ .

**Figure 10-4 External Clock Timing**

## 10.6 Phase Locked Loop Timing

**Table 10-11 PLL Timing**

Characteristic	Symbol	Min	Typ	Max	Unit
Internal reference relaxation oscillator frequency for the PLL	$f_{rosc}$	—	8	—	MHz
PLL output frequency <sup>1</sup> (24 x reference frequency)	$f_{op}$	—	192	—	MHz
PLL lock time <sup>2</sup>	$t_{lock}$	—	.1	1	ms
Cycle to cycle jitter	$t_{jitterpll}$		350		ps

- The core system clock will operate at 1/6 of the PLL output frequency.
- This is the time required after the PLL is enabled to ensure reliable operation.

## 10.7 Relaxation Oscillator Timing

**Table 10-12 Relaxation Oscillator Timing**

Characteristic	Symbol	Minimum	Typical	Maximum	Unit
Relaxation Oscillator output frequency <sup>1</sup> Normal Mode Standby Mode	$f_{op}$	—	8 400	—	MHz kHz
Relaxation Oscillator stabilization time <sup>2</sup>	$t_{roscs}$	—	1	3	$\mu$ s
Cycle-to-cycle jitter. This is measured on the CLKO signal (programmed prescaler_clock) over 264 clocks <sup>3</sup>	$t_{jitterosc}$	—	400		ps
Minimum tuning step size			.08		%
Maximum tuning step size			40		%
Variation over temperature -40°C to 105°C <sup>4</sup>			—	+3.0 to -3.0	%

1. Output frequency after application of trim value, at 25°C.
2. This is the time required from standby to normal mode transition.
3.  $J_A$  is required to meet SCI requirements.
4. See [Figure 10-5](#).

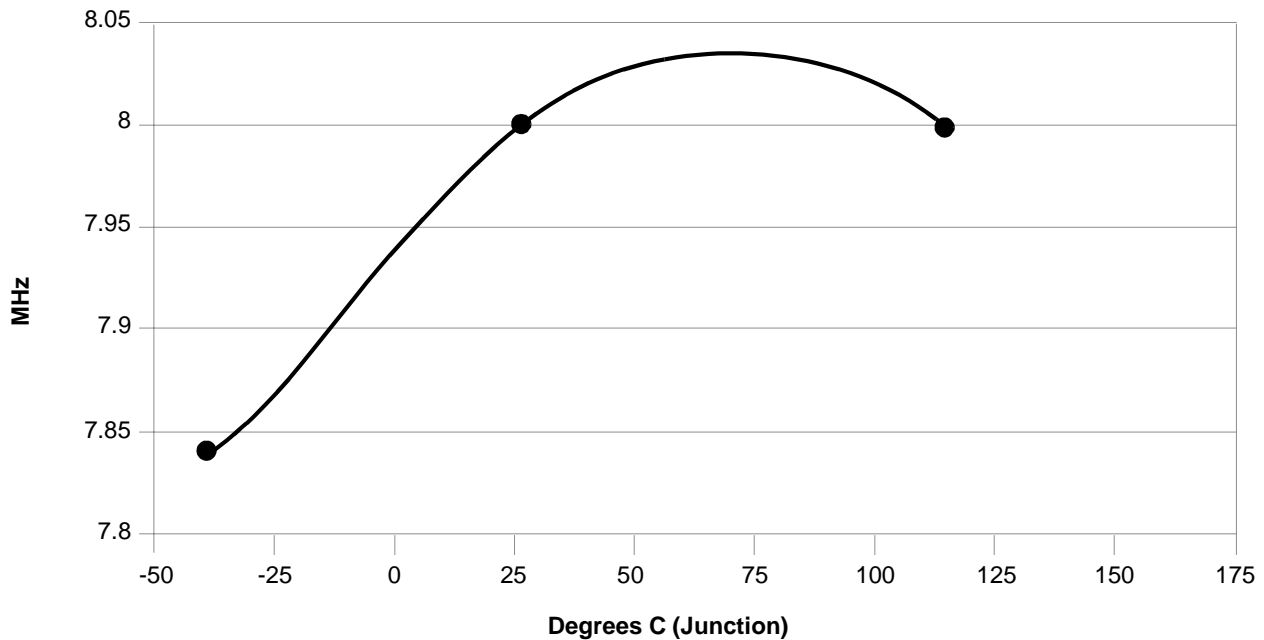

**Figure 10-5 Relaxation Oscillator Temperature Variation (Typical)**

## 10.8 Reset, Stop, Wait, Mode Select, and Interrupt Timing

Note: All the address and data buses described here are internal.

**Table 10-13 Reset, Stop, Wait, Mode Select, and Interrupt Timing<sup>1,2</sup>**

Characteristic	Symbol	Typical Min	Typical Max	Unit	See Figure
Minimum $\overline{\text{RESET}}$ Assertion Duration	$t_{\text{RA}}$	4T	—	ns	
Minimum GPIO pin Assertion for Interrupt	$t_{\text{IW}}$	2T	—	ns	<a href="#">10-6</a>
$\overline{\text{RESET}}$ deassertion to First Address Fetch <sup>3</sup>	$t_{\text{RDA}}$	$96T_{\text{OSC}} + 64T$	$97T_{\text{OSC}} + 65T$	ns	
Delay from Interrupt Assertion to Fetch of first instruction (exiting Stop)	$t_{\text{IF}}$	—	6T	ns	

1. In the formulas, T = clock cycle and  $T_{\text{OSC}}$  = oscillator clock cycle. For an operating frequency of 32MHz, T = 31.25ns. At 8MHz (used during Reset and Stop modes), T = 125ns.

2. Parameters listed are guaranteed by design.

3. During Power-On Reset, it is possible to use the 56F8014 internal reset stretching circuitry to extend this period to  $2^{21}T$ .

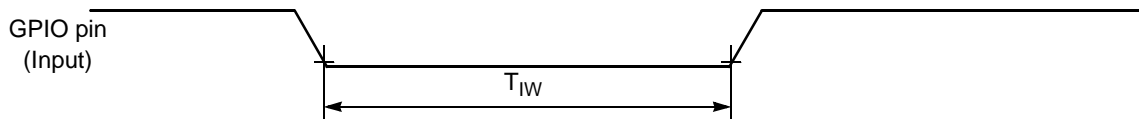

**Figure 10-6 GPIO Interrupt Timing (Negative Edge-Sensitive)**

## 10.9 Serial Peripheral Interface (SPI) Timing

Table 10-14 SPI Timing<sup>1</sup>

Characteristic	Symbol	Min	Max	Unit	See Figure
Cycle time Master Slave	$t_C$	125 62.5	— —	ns ns	10-7, 10-8, 10-9, 10-10
Enable lead time Master Slave	$t_{ELD}$	— 31	— —	ns ns	10-10
Enable lag time Master Slave	$t_{ELG}$	— 125	— —	ns ns	10-10
Clock (SCK) high time Master Slave	$t_{CH}$	50 31	— —	ns ns	10-7, 10-8, 10-9, 10-10
Clock (SCK) low time Master Slave	$t_{CL}$	50 31	— —	ns ns	10-10
Data set-up time required for inputs Master Slave	$t_{DS}$	20 0	— —	ns ns	10-7, 10-8, 10-9, 10-10
Data hold time required for inputs Master Slave	$t_{DH}$	0 2	— —	ns ns	10-7, 10-8, 10-9, 10-10
Access time (time to data active from high-impedance state) Slave	$t_A$	4.8	15	ns	10-10
Disable time (hold time to high-impedance state) Slave	$t_D$	3.7	15.2	ns	10-10
Data Valid for outputs Master Slave (after enable edge)	$t_{DV}$	— —	4.5 20.4	ns ns	10-7, 10-8, 10-9, 10-10
Data invalid Master Slave	$t_{DI}$	0 0	— —	ns ns	10-7, 10-8, 10-9, 10-10
Rise time Master Slave	$t_R$	— —	11.5 10.0	ns ns	10-7, 10-8, 10-9, 10-10
Fall time Master Slave	$t_F$	— —	9.7 9.0	ns ns	10-7, 10-8, 10-9, 10-10

1. Parameters listed are guaranteed by design.

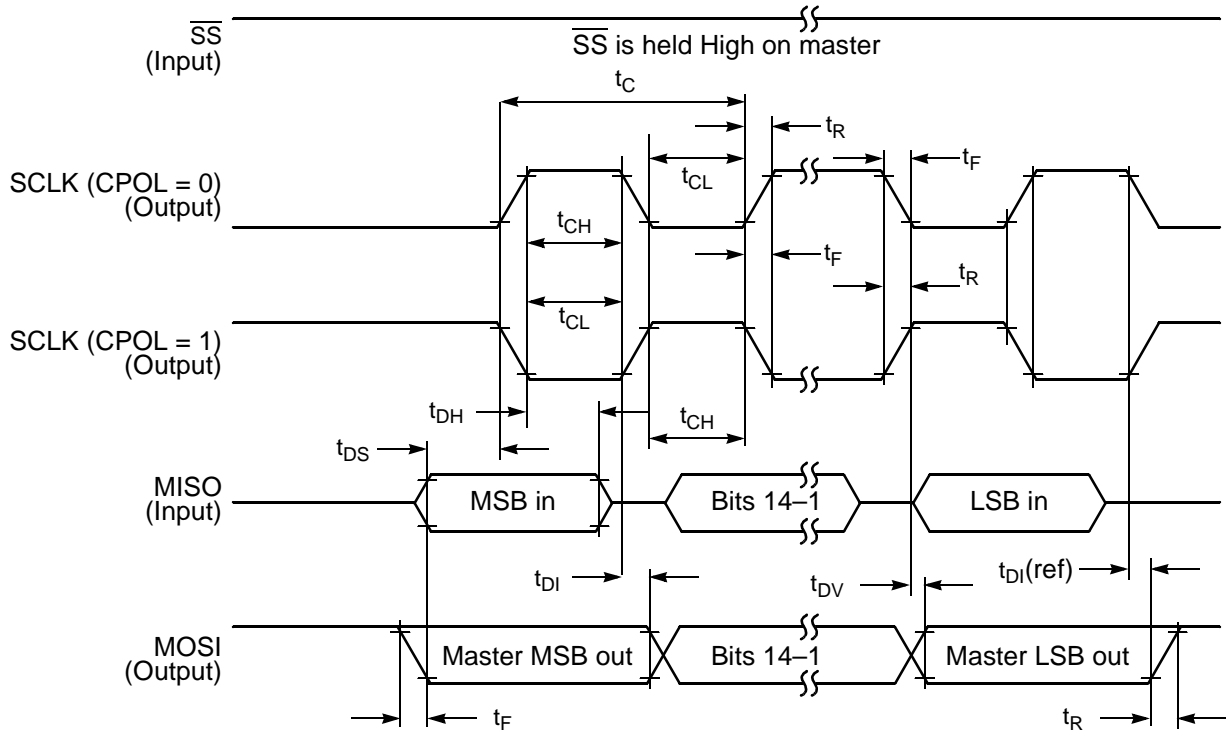

Figure 10-7 SPI Master Timing (CPHA = 0)

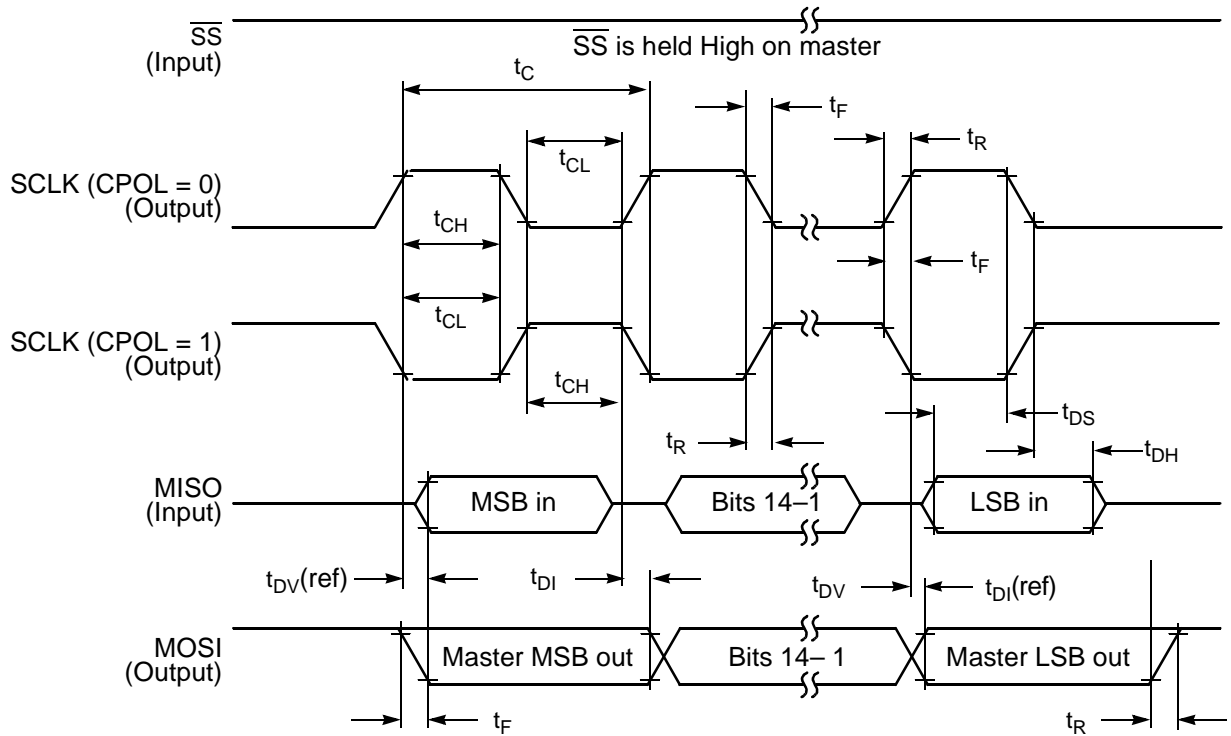
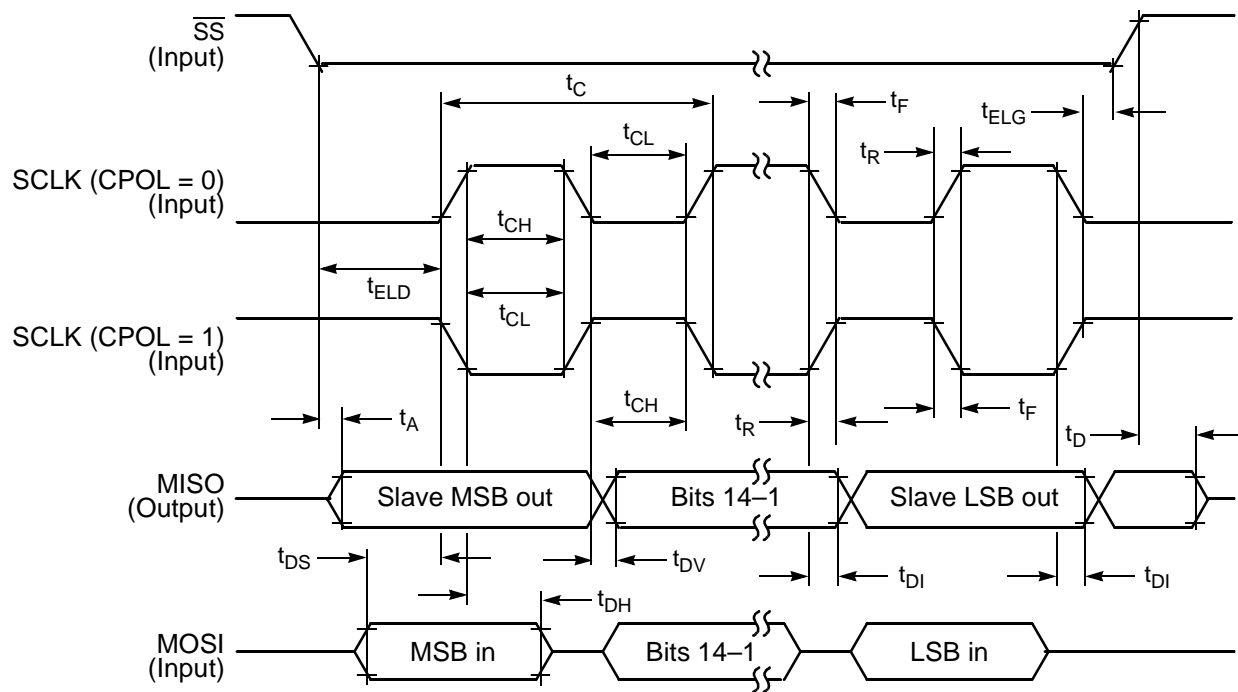
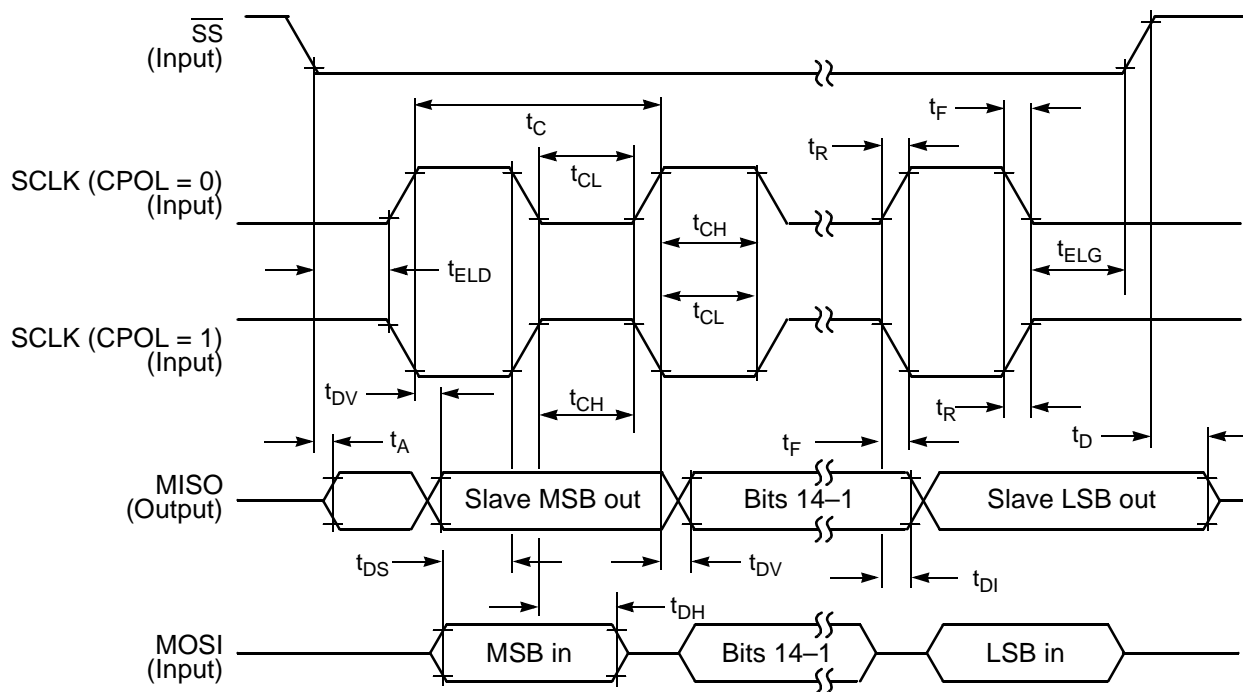

Figure 10-8 SPI Master Timing (CPHA = 1)



**Figure 10-9 SPI Slave Timing (CPHA = 0)**



**Figure 10-10 SPI Slave Timing (CPHA = 1)**

## 10.10 Quad Timer Timing

**Table 10-15 Timer Timing<sup>1, 2</sup>**

Characteristic	Symbol	Min	Max	Unit	See Figure
Timer input period	$P_{IN}$	$2T + 6$	—	ns	<a href="#">10-11</a>
Timer input high / low period	$P_{INHL}$	$1T + 3$	—	ns	<a href="#">10-11</a>
Timer output period	$P_{OUT}$	125	—	ns	<a href="#">10-11</a>
Timer output high / low period	$P_{OUTHL}$	50	—	ns	<a href="#">10-11</a>

1. In the formulas listed, T = the clock cycle. For 32MHz operation, T = 31.25ns.

2. Parameters listed are guaranteed by design.

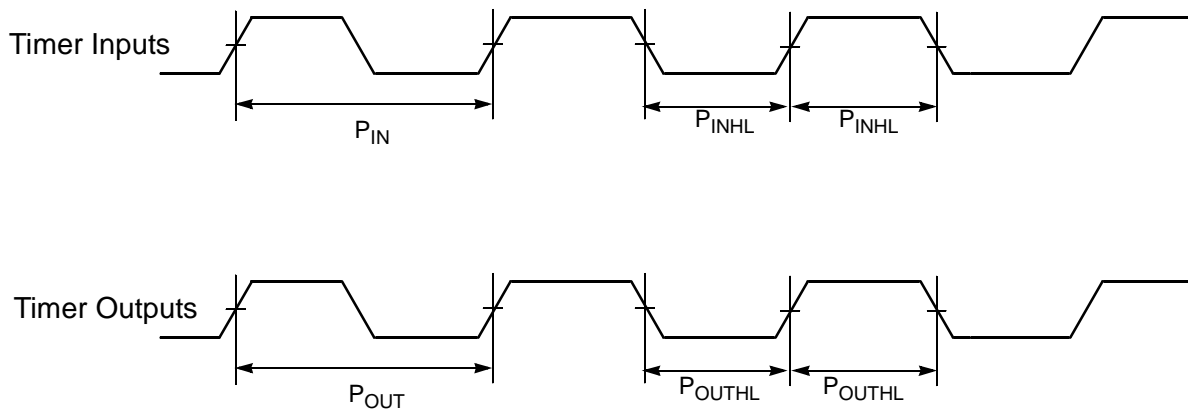

**Figure 10-11 Timer Timing**

## 10.11 Serial Communication Interface (SCI) Timing

**Table 10-16 SCI Timing<sup>1</sup>**

Characteristic	Symbol	Min	Max	Unit	See Figure
Baud Rate <sup>2</sup>	BR	—	( $f_{MAX}/16$ )	Mbps	—
RXD <sup>3</sup> Pulse Width	RXD <sub>PW</sub>	0.965/BR	1.04/BR	ns	<a href="#">10-12</a>
TXD <sup>4</sup> Pulse Width	TXD <sub>PW</sub>	0.965/BR	1.04/BR	ns	<a href="#">10-13</a>
LIN Slave Mode					
Deviation of slave node clock from nominal clock rate before synchronization	F <sub>TOL_UNSYNCH</sub>	-14	14	%	
Deviation of slave node clock relative to the master node clock after synchronization	F <sub>TOL_SYNCH</sub>	-2	2	%	
Minimum break character length	T <sub>BREAK</sub>	13		Master node bit periods	
		11		Slave node bit periods	

- Parameters listed are guaranteed by design.
- $f_{MAX}$  is the frequency of operation of the system clock in MHz, which is 32MHz for the 56F8014 device.
- The RXD pin in SCI0 is named RXD0 and the RXD pin in SCI1 is named RXD1.
- The TXD pin in SCI0 is named TXD0 and the TXD pin in SCI1 is named TXD1.



**Figure 10-12 RXD Pulse Width**



**Figure 10-13 TXD Pulse Width**

## 10.12 Inter-Integrated Circuit Interface (I<sup>2</sup>C) Timing

Table 10-17 I<sup>2</sup>C Timing

Characteristic	Symbol	Standard Mode		Fast Mode		Unit
		Minimum	Maximum	Minimum	Maximum	
SCL Clock Frequency	$f_{SCL}$	0	100	0	400	kHz
Hold time (repeated ) START condition. After this period, the first clock pulse is generated.	$t_{HD; STA}$	4.0		0.6		$\mu s$
LOW period of the SCL clock	$t_{LOW}$	4.7		1.25		$\mu s$
HIGH period of the SCL clock	$t_{HIGH}$	4.0		0.6		$\mu s$
Set-up time for a repeated START condition	$t_{SU; STA}$	4.7		0.6		$\mu s$
Data hold time for I <sup>2</sup> C bus devices	$t_{HD; DAT}$	0 <sup>1</sup>	3.45 <sup>2</sup>	0 <sup>1</sup>	0.9 <sup>2</sup>	$\mu s$
Data set-up time	$t_{SU; DAT}$	250		100 <sup>3</sup>		ns
Rise time of both SDA and SCL signals	$t_r$		1000	$2 + 0.1C_b^4$	300	ns
Fall time of both SDA and SCL signals	$t_f$		300	$2 + 0.1C_b^4$	300	ns
Set-up time for STOP condition	$t_{SU; STO}$	4.0		0.6		$\mu s$
Bus free time between STOP and START condition	$t_{BUF}$	4.7		1.3		$\mu s$
Pulse width of spikes that must be suppressed by the input filter	$t_{SP}$	N/A	N/A	0.0	50	ns

1. A device must internally provide a hold time of at least 300ns for the SDA signal (referred to the  $V_{IH}$  min of the SCL signal) to bridge the undefined region of the falling edge of SCL.
2. The maximum  $t_{HD; DAT}$  has only to be met if the device does not stretch the LOW period ( $t_{LOW}$ ) of the SCL signal.
3. A Fast mode I<sup>2</sup>C bus device can be used in a Standard mode I<sup>2</sup>C bus system, but the requirement  $t_{SU; DAT} \geq 250ns$  must then be met. This will automatically be the case if the device does not stretch the LOW period of the SCL signal. If such a device does stretch the LOW period of the SCL signal, it must output the next data bit to the SDA line  
 $t_{rmax} + t_{SU; DAT} = 1000 + 250 = 1250ns$  (according to the Standard mode I<sup>2</sup>C bus specification) before the SCL line is released.
4.  $C_b$  = total capacitance of the one bus line in pF.

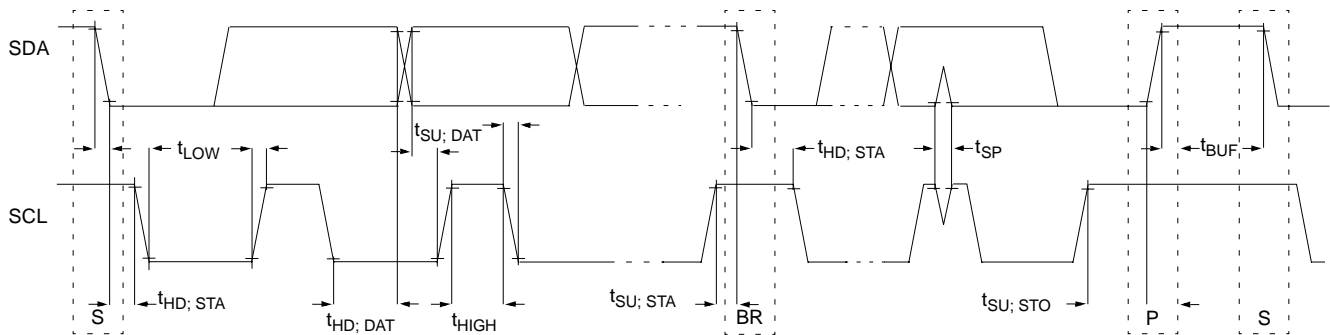

Figure 10-14 Timing Definition for Fast and Standard Mode Devices on the I<sup>2</sup>C Bus

### 10.13 JTAG Timing

Table 10-18 JTAG Timing

Characteristic	Symbol	Min	Max	Unit	See Figure
TCK frequency of operation <sup>1</sup>	$f_{OP}$	DC	SYS_CLK/8	MHz	10-15
TCK clock pulse width	$t_{PW}$	50	—	ns	10-15
TMS, TDI data set-up time	$t_{DS}$	5	—	ns	10-16
TMS, TDI data hold time	$t_{DH}$	5	—	ns	10-16
TCK low to TDO data valid	$t_{DV}$	—	30	ns	10-16
TCK low to TDO tri-state	$t_{TS}$	—	30	ns	10-16

1. TCK frequency of operation must be less than 1/8 the processor rate.

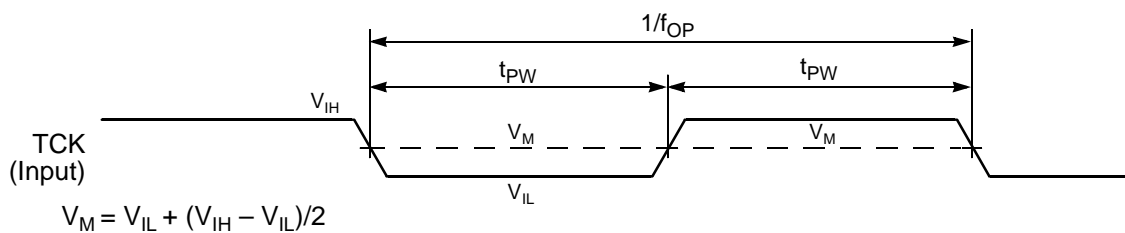

Figure 10-15 Test Clock Input Timing Diagram

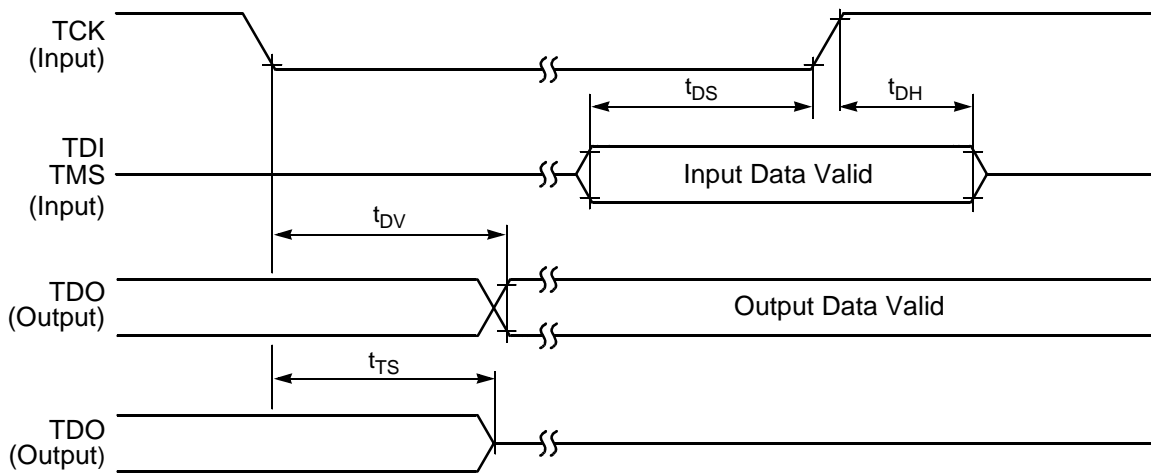

Figure 10-16 Test Access Port Timing Diagram

## 10.14 Analog-to-Digital Converter (ADC) Parameters

Table 10-19 ADC Parameters<sup>1</sup>

Characteristic	Symbol	Min	Typ	Max	Unit
Input voltages	$V_{ADIN}$	$V_{REFL}$	—	$V_{REFH}$	V
Resolution	$R_{ES}$	12	—	12	Bits
Integral Non-Linearity <sup>2</sup> (Full input signal range)	INL	—	+/- 3	+/- 4	LSB <sup>3</sup>
Integral Non-Linearity <sup>4</sup> (10% to 90% input signal range)	INL	—	+/- 2	+/- 3	LSB <sup>3</sup>
Differential Non-Linearity	DNL	—	$-1 < DNL < +1$	$< +1$	LSB <sup>3</sup>
Monotonicity	GUARANTEED				
ADC internal clock	$f_{ADIC}$	0.1	—	5.33	MHz
Conversion range	$R_{AD}$	$V_{REFL}$	—	$V_{REFH}$	V
ADC power-up time <sup>5</sup>	$t_{ADPU}$	—	6	13	$t_{AIC}$ cycles <sup>6</sup>
Recovery from auto standby	$t_{REC}$	—	0	1	$t_{AIC}$ cycles <sup>6</sup>
Conversion time	$t_{ADC}$	—	6	—	$t_{AIC}$ cycles <sup>6</sup>
Sample time	$t_{ADS}$	—	1	—	$t_{AIC}$ cycles <sup>6</sup>
Input capacitance	$C_{ADI}$	—	See <a href="#">Figure 10-17</a>	—	pF
Input impedance	$X_{IN}$	—	See <a href="#">Figure 10-17</a>	—	Ohms
Input injection current <sup>7</sup> , per pin	$I_{ADI}$	—	—	3	mA
$V_{REFH}$ current	$I_{VREFH}$	—	0	—	$\mu$ A

**Table 10-19 ADC Parameters<sup>1</sup> (Continued)**

Characteristic	Symbol	Min	Typ	Max	Unit
Offset Voltage Internal Ref	$V_{\text{OFFSET}}$	—	+/- 8	+/- 15	mV
Gain Error (transfer gain)	$E_{\text{GAIN}}$	.99	1	1.01	—
Offset Voltage External Ref	$V_{\text{OFFSET}}$	—	+/- 3	TBD	mV
Signal-to-noise ratio	SNR	TBD	62 to 65.7		dB
Total Harmonic Distortion	THD	TBD	63 to 68		dB
Spurious Free Dynamic Range	SFDR	TBD	67 to 70.3		dB
Signal-to-noise plus distortion	SINAD	TBD	61 to 63.9		dB
Effective Number Of Bits	ENOB	9.1	9.6 to 10.4		Bits

1. All measurements were made at  $V_{\text{DD}} = 3.3\text{V}$ ,  $V_{\text{REFH}} = 3.3\text{V}$ , and  $V_{\text{REFL}} = \text{ground}$
2. INL measured from  $V_{\text{IN}} = V_{\text{REFL}}$  to  $V_{\text{IN}} = V_{\text{REFH}}$
3. LSB = Least Significant Bit
4. INL measure from  $V_{\text{IN}} = 0.1 V_{\text{REFH}}$  to  $V_{\text{IN}} = 0.9V_{\text{REFH}}$
5. Includes power-up of ADC and  $V_{\text{REF}}$
6. ADC clock cycles
7. The current that can be injected or sourced from an unselected ADC signal input without impacting the performance of the ADC.

## 10.15 Equivalent Circuit for ADC Inputs

**Figure 10-17** illustrates the ADC input circuit during sample and hold. S1 and S2 are always open/closed at the same time that S3 is closed/open. When S1/S2 are closed & S3 is open, one input of the sample and hold circuit moves to  $(V_{\text{REFH}} - V_{\text{REFL}})/2$ , while the other charges to the analog input voltage. When the switches are flipped, the charge on C1 and C2 are averaged via S3, with the result that a single-ended analog input is switched to a differential voltage centered about  $(V_{\text{REFH}} - V_{\text{REFL}})/2$ . The switches switch on every cycle of the ADC clock (open one-half ADC clock, closed one-half ADC clock). Note that there are additional capacitances associated with the analog input pad, routing, etc., but these do not filter into the S/H output voltage, as S1 provides isolation during the charge-sharing phase.

One aspect of this circuit is that there is an on-going input current, which is a function of the analog input voltage,  $V_{\text{REF}}$  and the ADC clock frequency.

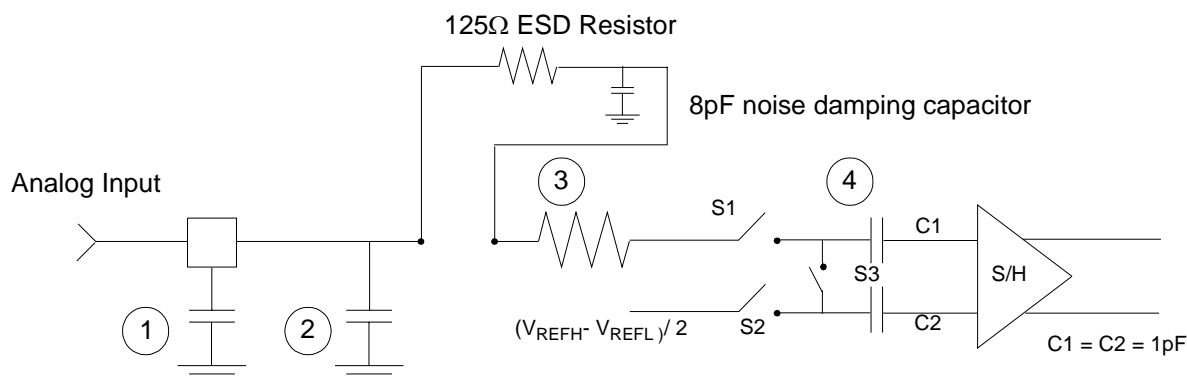

1. Parasitic capacitance due to package, pin-to-pin and pin-to-package base coupling; 1.8pF
2. Parasitic capacitance due to the chip bond pad, ESD protection devices and signal routing; 2.04pF
3. Equivalent resistance for the channel select mux; 100 ohms
4. Sampling capacitor at the sample and hold circuit. Capacitor C1 is normally disconnected from the input and is only connected to it at sampling time; 1.4pf
5. Equivalent input impedance, when the the input is selected =  $\frac{1}{(\text{ADC Clock Rate}) \times 1.4 \times 10^{-12}}$

**Figure 10-17 Equivalent Circuit for A/D Loading**

## 10.16 Power Consumption

See [Section 10.1](#) for a list of IDD requirements for the 56F8014. This section provides additional detail which can be used to optimize power consumption for a given application.

Power consumption is given by the following equation:

$$\begin{aligned} \text{Total power} = & \text{A: internal [static component]} \\ & +\text{B: internal [state-dependent component]} \\ & +\text{C: internal [dynamic component]} \\ & +\text{D: external [dynamic component]} \\ & +\text{E: external [static]} \end{aligned}$$

A, the internal [static component], is comprised of the DC bias currents for the oscillator, leakage currents, PLL, and voltage references. These sources operate independently of processor state or operating frequency.

B, the internal [state-dependent component], reflects the supply current required by certain on-chip resources only when those resources are in use. These include RAM, Flash memory and the ADCs.

C, the internal [dynamic component], is classic  $C \cdot V^2 \cdot F$  CMOS power dissipation corresponding to the 56800E core and standard cell logic.

D, the external [dynamic component], reflects power dissipated on-chip as a result of capacitive loading on the external pins of the chip. This is also commonly described as  $C \cdot V^2 \cdot F$ , although simulations on two of the I/O cell types used on the 56800E reveal that the power-versus-load curve does have a non-zero Y-intercept.

**Table 10-20 I/O Loading Coefficients at 10MHz**

	Intercept	Slope
8mA drive	1.3	0.11mW / pF
4mA drive	1.15mW	0.11mW / pF

Power due to capacitive loading on output pins is (first order) a function of the capacitive load and frequency at which the outputs change. **Table 10-20** provides coefficients for calculating power dissipated in the I/O cells as a function of capacitive load. In these cases:

$$TotalPower = \Sigma((Intercept + Slope*Clod)*frequency/10MHz)$$

where:

- Summation is performed over all output pins with capacitive loads
- TotalPower is expressed in mW
- Clod is expressed in pF

Because of the low duty cycle on most device pins, power dissipation due to capacitive loads was found to be fairly low when averaged over a period of time.

E, the external [static component], reflects the effects of placing resistive loads on the outputs of the device. Sum the total of all  $V^2/R$  or  $IV$  to arrive at the resistive load contribution to power. Assume  $V = 0.5$  for the purposes of these rough calculations. For instance, if there is a total of eight PWM outputs driving 10mA into LEDs, then  $P = 8*.5*.01 = 40mW$ .

In previous discussions, power consumption due to parasitics associated with pure input pins is ignored, as it is assumed to be negligible.

## Part 11 Packaging

### 11.1 56F8014 Package and Pin-Out Information

This section contains package and pin-out information for the 56F8014. This device comes in a 32-pin Low-profile Quad Flat Pack (LQFP). [Figure 11-1](#) shows the package outline for the 32-pin LQFP, [Figure 11-2](#) shows the mechanical parameters for this package, and [Table 11-1](#) lists the pin-out for the 32-pin LQFP.

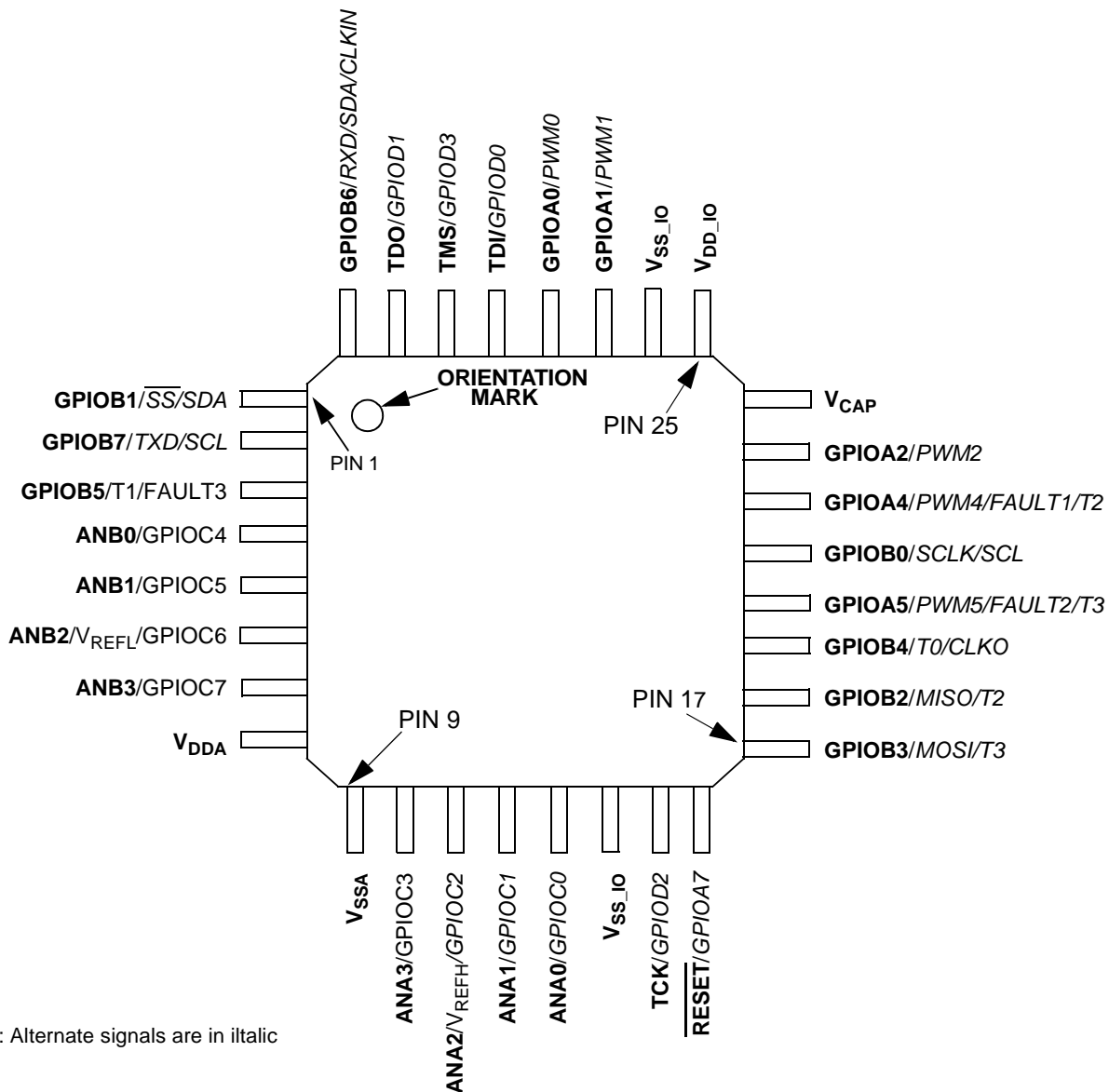

Figure 11-1 Top View, 56F8014 32-Pin LQFP Package

**Table 11-1 56F8014 32-Pin LQFP Package Identification by Pin Number<sup>1</sup>**

Pin No.	Signal Name	Pin No.	Signal Name	Pin No.	Signal Name	Pin No.	Signal Name
1	<b>GPIOB1</b> <i>SS,SDA</i>	9	<b>V<sub>SSA</sub></b>	17	<b>GPIOB3</b> <i>MOSI,T3</i>	25	<b>V<sub>DD_IO</sub></b>
2	<b>GPIOB7</b> <i>TXD,SCL</i>	10	<b>ANA3</b> <i>GPIOC3</i>	18	<b>GPIOB2</b> <i>MISO,T2</i>	26	<b>V<sub>SS_IO</sub></b>
3	<b>GPIOB5</b> <i>T1,FAULT3</i>	11	<b>ANA2</b> <i>V<sub>REFH</sub>,GPIOC2</i>	19	<b>GPIOB4</b> <i>T0,CLKO</i>	27	<b>GPIOA1</b> <i>PWM1</i>
4	<b>ANB0</b> <i>GPIOC4</i>	12	<b>ANA1</b> <i>GPIOC1</i>	20	<b>GPIOA5</b> <i>PWM5,FAULT2,T3</i>	28	<b>GPIOA0</b> <i>PWM0</i>
5	<b>ANB1</b> <i>GPIOC5</i>	13	<b>ANA0</b> <i>GPIOC0</i>	21	<b>GPIOB0</b> <i>SCLK,CL</i>	29	<b>TDI</b> <i>GPIOD0</i>
6	<b>ANB2</b> <i>V<sub>REFL</sub>,GPIOC6</i>	14	<b>V<sub>SS_IO</sub></b>	22	<b>GPIOA4</b> <i>PWM4/FAULT1/T2</i>	30	<b>TMS</b> <i>GPIOD3</i>
7	<b>ANB3</b> <i>GPIOC7</i>	15	<b>TCK</b> <i>GPIOD2</i>	23	<b>GPIOA2</b> <i>PWM2</i>	31	<b>TDO</b> <i>GPIOD1</i>
8	<b>V<sub>DDA</sub></b>	16	<b>RESET</b> <i>GPIOA7</i>	24	<b>V<sub>CAP</sub></b>	32	<b>GPIOB6</b> <i>RXD,SDA,CLKIN</i>

1. Alternate signals are in italic

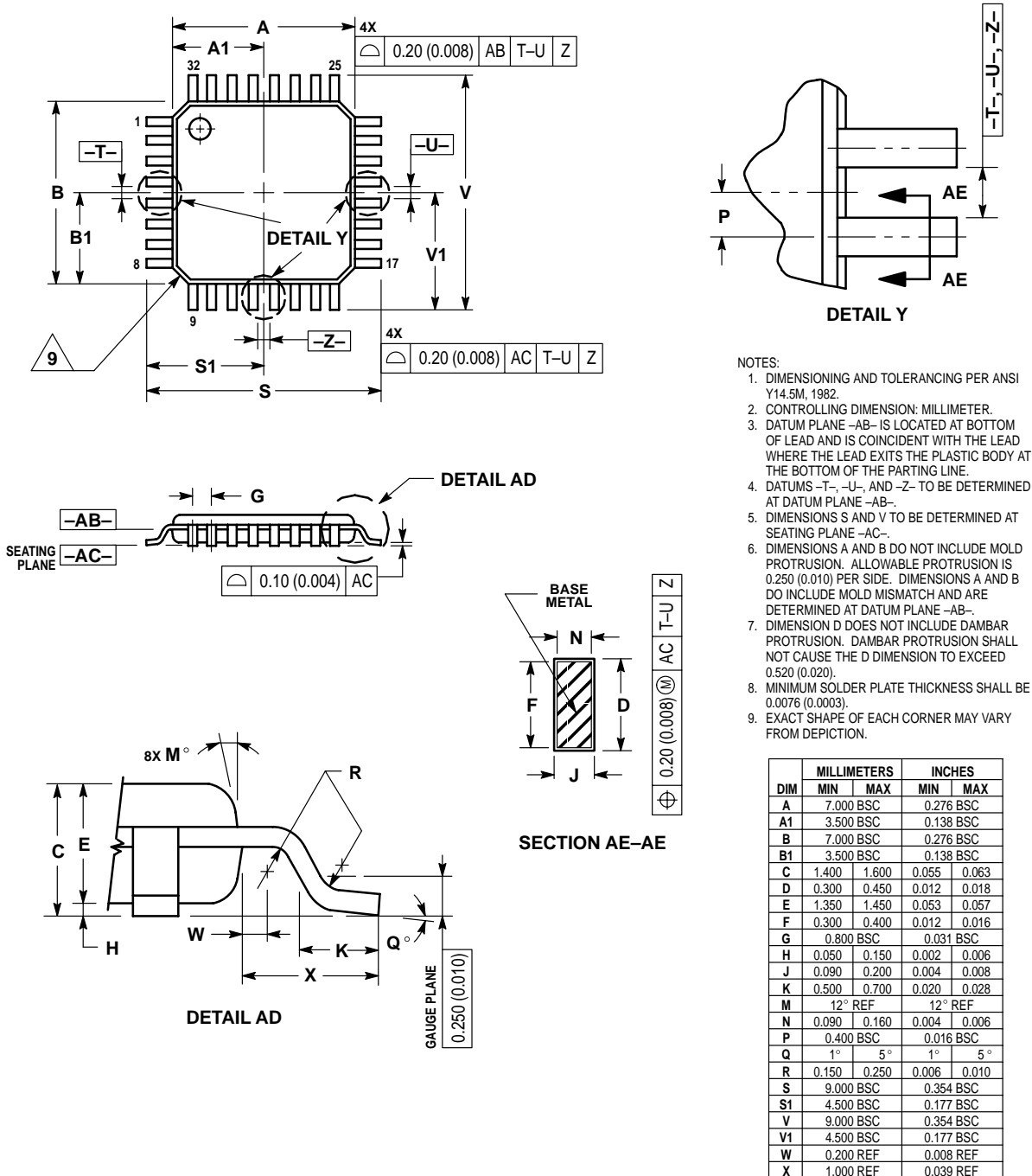

Figure 11-2 56F8014 32-Pin LQFP Mechanical Information

## Part 12 Design Considerations

### 12.1 Thermal Design Considerations

An estimation of the chip junction temperature,  $T_J$ , can be obtained from the equation:

$$T_J = T_A + (R_{\theta JA} \times P_D)$$

where:

$T_A$  = Ambient temperature for the package ( $^{\circ}\text{C}$ )

$R_{\theta JA}$  = Junction-to-ambient thermal resistance ( $^{\circ}\text{C}/\text{W}$ )

$P_D$  = Power dissipation in the package (W)

The junction-to-ambient thermal resistance is an industry-standard value that provides a quick and easy estimation of thermal performance. Unfortunately, there are two values in common usage: the value determined on a single-layer board and the value obtained on a board with two planes. For packages such as the PBGA, these values can be different by a factor of two. Which value is closer to the application depends on the power dissipated by other components on the board. The value obtained on a single layer board is appropriate for the tightly packed printed circuit board. The value obtained on the board with the internal planes is usually appropriate if the board has low-power dissipation and the components are well separated.

When a heat sink is used, the thermal resistance is expressed as the sum of a junction-to-case thermal resistance and a case-to-ambient thermal resistance:

$$R_{\theta JA} = R_{\theta JC} + R_{\theta CA}$$

where:

$R_{\theta JA}$  = Package junction-to-ambient thermal resistance ( $^{\circ}\text{C}/\text{W}$ )

$R_{\theta JC}$  = Package junction-to-case thermal resistance ( $^{\circ}\text{C}/\text{W}$ )

$R_{\theta CA}$  = Package case-to-ambient thermal resistance ( $^{\circ}\text{C}/\text{W}$ )

$R_{\theta JC}$  is device related and cannot be influenced by the user. The user controls the thermal environment to change the case to ambient thermal resistance,  $R_{\theta CA}$ . For instance, the user can change the size of the heat sink, the air flow around the device, the interface material, the mounting arrangement on printed circuit board, or change the thermal dissipation on the printed circuit board surrounding the device.

To determine the junction temperature of the device in the application when heat sinks are not used, the Thermal Characterization Parameter ( $\Psi_{JT}$ ) can be used to determine the junction temperature with a measurement of the temperature at the top center of the package case using the following equation:

$$T_J = T_T + (\Psi_{JT} \times P_D)$$

where:

$T_T$  = Thermocouple temperature on top of package ( $^{\circ}\text{C}$ )

$\Psi_{JT}$  = Thermal characterization parameter ( $^{\circ}\text{C}/\text{W}$ )

$P_D$  = Power dissipation in package (W)

The thermal characterization parameter is measured per JESD51-2 specification using a 40-gauge type T thermocouple epoxied to the top center of the package case. The thermocouple should be positioned so

that the thermocouple junction rests on the package. A small amount of epoxy is placed over the thermocouple junction and over about 1mm of wire extending from the junction. The thermocouple wire is placed flat against the package case to avoid measurement errors caused by cooling effects of the thermocouple wire.

When heat sink is used, the junction temperature is determined from a thermocouple inserted at the interface between the case of the package and the interface material. A clearance slot or hole is normally required in the heat sink. Minimizing the size of the clearance is important to minimize the change in thermal performance caused by removing part of the thermal interface to the heat sink. Because of the experimental difficulties with this technique, many engineers measure the heat sink temperature and then back-calculate the case temperature using a separate measurement of the thermal resistance of the interface. From this case temperature, the junction temperature is determined from the junction-to-case thermal resistance.

## 12.2 Electrical Design Considerations

### CAUTION

**This device contains protective circuitry to guard against damage due to high static voltage or electrical fields. However, normal precautions are advised to avoid application of any voltages higher than maximum-rated voltages to this high-impedance circuit. Reliability of operation is enhanced if unused inputs are tied to an appropriate voltage level.**

Use the following list of considerations to assure correct operation of the 56F8014:

- Provide a low-impedance path from the board power supply to each  $V_{DD}$  pin on the 56F8014 and from the board ground to each  $V_{SS}$  (GND) pin
- The minimum bypass requirement is to place 0.01–0.1 $\mu$ F capacitors positioned as close as possible to the package supply pins. The recommended bypass configuration is to place one bypass capacitor on each of the  $V_{DD}/V_{SS}$  pairs, including  $V_{DDA}/V_{SSA}$ . Ceramic and tantalum capacitors tend to provide better tolerances.
- Ensure that capacitor leads and associated printed circuit traces that connect to the chip  $V_{DD}$  and  $V_{SS}$  (GND) pins are as short as possible
- Bypass the  $V_{DD}$  and  $V_{SS}$  with approximately 100 $\mu$ F, plus the number of 0.1 $\mu$ F ceramic capacitors
- PCB trace lengths should be minimal for high-frequency signals
- Consider all device loads as well as parasitic capacitance due to PCB traces when calculating capacitance. This is especially critical in systems with higher capacitive loads that could create higher transient currents in the  $V_{DD}$  and  $V_{SS}$  circuits.
- Take special care to minimize noise levels on the  $V_{REF}$ ,  $V_{DDA}$  and  $V_{SSA}$  pins

- 
- Using separate power planes for  $V_{DD}$  and  $V_{DDA}$  and separate ground planes for  $V_{SS}$  and  $V_{SSA}$  is recommended. Connect the separate analog and digital power and ground planes as close as possible to power supply outputs. If both analog circuit and digital circuit are powered by the same power supply, it is advisable to connect a small inductor or ferrite bead in serial with both  $V_{DDA}$  and  $V_{SSA}$  traces.
  - It is highly desirable to physically separate analog components from noisy digital components by ground planes. Do not place an analog trace in parallel with digital traces. It is also desirable to place an analog ground trace around an analog signal trace to isolate it from digital traces.
  - Because the Flash memory is programmed through the JTAG/EOnCE port, SPI, SCI or I<sup>2</sup>C, the designer should provide an interface to this port if in-circuit Flash programming is desired.

## Part 13 Ordering Information

**Table 13-1** lists the pertinent information needed to place an order. Consult a Freescale Semiconductor sales office or authorized distributor to determine availability and to order parts.

**Table 13-1 56F8014 Ordering Information**

Part	Supply Voltage	Package Type	Pin Count	Frequency (MHz)	Ambient Temperature Range	Order Number
MC56F8014	3.0–3.6 V	Low-Profile Quad Flat Pack (LQFP)	32	32	-40° to +105° C	MC56F8014VFAE

## Part 14 Appendix

Register acronyms are revised from previous device data sheets to provide a cleaner register description. A cross reference to legacy and revised acronyms are provided in the following table.

Module	Register Name	Peripheral Reference Manual		Data Sheet		Processor Expert Acronym	Memory Address	
		New Acronym	Legacy Acronym	New Acronym	Legacy Acronym		Start	End
ADC	Control Register 1	CTRL1	ADCR1	ADC_CTRL1	ADC_ADCR1	ADC_ADCR1	0xF080	
	Control Register 2	CTRL2	ADCR2	ADC_CTRL2	ADC_ADCR2	ADC_ADCR2	0xF081	
	Zero Crossing Control Register	ZXCTRL	ADZCC	ADC_ZXCTRL	ADC_ADZCC	ADC_ADZCC	0xF082	
	Channel List Register 1	CLIST1	ADLST1	ADC_CLIST1	ADC_ADLST1	ADC_ADLST1	0xF083	
	Channel List Register 2	CLIST2	ADLST2	ADC_CLIST2	ADC_ADLST2	ADC_ADLST2	0xF084	
	Sample Disable Register	SDIS	ADSDIS	ADC_SDIS	ADC_ADSDIS	ADC_ADSDIS	0xF085	
	Status Register	STAT	ADSTAT	ADC_STAT	ADC_ADSTAT	ADC_ADSTAT	0xF086	
	Limit Status Register	LIMSTAT	ADLSTAT	ADC_LIMSTAT	ADC_ADLSTAT	ADC_ADLSTAT	0xF087	
	Zero Crossing Status Register	ZXSTAT	ADZCSTAT	ADC_ZXSTAT	ADC_ADZCSTAT	ADC_ADZCSTAT	0xF088	
	Result Registers 0-7	RSLT0-7	ADRSLT0-7	ADC_RSLT0-7	ADC_ADRSLT0-7	ADC_ADRSLT0-7	0xF089	0XF090
	Low Limit Registers 0-7	LOLIM0-7	ADLLMT0-7	ADC_LOLIM0-7	ADC_ADLLMT0-7	ADC_ADLLMT0-7	0XF091	0XF098
	High Limit Registers 0-7	HILIM0-7	ADHLMT0-7	ADC_HILIM0-7	ADC_ADHLMT0-7	ADC_ADHLMT0-7	0XF099	0XF0A0
	Offset Registers 0-7	OFFST0-7	ADOF0-7	ADC_OFFST0-7	ADC_ADOF0-7	ADC_ADOF0-7	0XF0A1	0XF0A8
	Power Control Register	PWR	ADPOWER	ADC_PWR	ADC_ADPOWER	ADC_ADPOWER	0XF0A9	
Voltage Reference Register	CAL	ADCAL	ADC_VREF	ADC_ADCAL	ADC_CAL	0XF0AA		
COP	Control Register	CTRL	COPCTL	COP_CTRL	COPCTL	COPCTL	0XF0E0	
	Time-Out Register	TOUT	COPTO	COP_TOUT	COPTO	COPTO	0XF0E1	
	Counter Register	CNTR	COPCTR	COP_CNTR	COPCTR	COPCTR	0XF0E2	
I <sup>2</sup> C	Address Register	ADDR	IBAD	I2C_ADDR	I2C_IBAD	IBAD	0xF0D0	
	Frequency Divider Register	FDIV	IBFD	I2C_FDIV	I2C_IBFD	IBFD	0xF0D1	
	Control Register	CTRL	IBCR	I2C_CTRL	I2C_IBCR	IBCR	0xF0D2	
	Status Register	STAT	IBSR	I2C_STAT	I2C_IBSR	IBSR	0xF0D3	
	Data I/O Register	DATA	IBDR	I2C_DATA	I2C_IBDR	IBDR	0xF0D4	
	Noise Filter Register	NFILT	IBNR	I2C_NFILT	I2C_IBNR	IBNR	0xF0D5	
ITCN	Interrupt Priority Register 0-4	N/A	N/A	ITCN_IPR0-4	ITCN_IPR0-4	INTC_IPR0-4	0XF060	0XF064
	Vector Base Address Register	N/A	N/A	ITCN_VBA	ITCN_VBA	INTC_VBA	0XF065	
	Fast Interrupt Match 0 Register	N/A	N/A	ITCN_FIM0	ITCN_FIM0	INTC_FIM0	0XF066	
	Fast Interrupt Vector Address Low 0	N/A	N/A	ITCN_FIVAL0	ITCN_FIVAL0	INTC_FIVAL0	0XF067	
	Fast Interrupt Vector Address High 0	N/A	N/A	ITCN_FIVAH0	ITCN_FIVAH0	INTC_FIVAH0	0XF068	
	Fast Interrupt Match 1 Register	N/A	N/A	ITCN_FIM1	ITCN_FIM1	INTC_FIM1	0xF069	
	Fast Interrupt Vector Address Low 1	N/A	N/A	ITCN_FIVAL1	ITCN_FIVAL1	INTC_FIVAL1	0xF06A	
	Fast Interrupt Vector Address High 1	N/A	N/A	ITCN_FIVAH1	ITCN_FIVAH1	INTC_FIVAH1	0xF06B	
	Interrupt Pending Register 0	N/A	N/A	ITCN_IRQP0	ITCN_IRQP0	INTC_IRQP0	0xF06C	
	Interrupt Pending Register 1	N/A	N/A	ITCN_IRQP1	ITCN_IRQP1	INTC_IRQP1	0xF06D	
	Interrupt Pending Register 2	N/A	N/A	ITCN_IRQP2	ITCN_IRQP2	INTC_IRQP2	0xF06E	
	Interrupt Control Register	N/A	N/A	ITCN_ICTRL	ITCN_ICTRL	INTC_ICTRL	0xF072	
	OCCS	Control Register	CTRL	PLLCR	OCCS_CTRL	PLLCR	PLLCR	0xF0F0
Divide-By Register		DIVBY	PLLD	OCCS_DIVBY	PLLD	PLLD	0xF0F1	
Status Register		STAT	PLLSR	OCCS_STAT	PLLSR	PLLSR	0xF0F2	
Shutdown Register		SHUTDN	SHUTDOWN	OCCS_SHUTDN	SHUTDOWN	SHUTDOWN	0xF0F4	
Oscillator Control Register		OCTRL	OSCTL	OCCS_OCTRL	OSCTL	OSCTL	0xF0F5	

Module	Register Name	Peripheral Reference Manual		Data Sheet		Processor Expert Acronym	Memory Address	
		New Acronym	Legacy Acronym	New Acronym	Legacy Acronym		Start	End
FM	Clock Divider Register	CLKDIV	FMCLKD	FM_CLKDIV	FMCLKD	FMCLKD	0xF400	
	Configuration Register	CNFG	FMCR	FM_CNFG	FMCR	FMCR	0xF401	
	Security High Half Register	SECHI	FMSECH	FM_SECHI	FMSECH	FMSECH	0xF403	
	Security Low Half Register	SECL0	FMSECL	FM_SECL0	FMSECL	FMSECL	0xF404	
	Protection Register	PROT	FMPROT	FM_PROT	FMPROT	FMPROT	0xF410	
	User Status Register	USTAT	FMUSTAT	FM_USTAT	FMUSTAT	FMUSTAT	0xF413	
	Command Register	CMD	FMCMD	FM_CMD	FMCMD	FMCMD	0xF414	
	Address Register	ADDR	FMADDR	FM_ADDR	FMADDR		0xF416	
	Data Buffer Register	DATA	FMDATA	FM_DATA	FMDATA		0xF418	
	Optional Data 1 Register	OPT1	FMOPT1	FM_OPT1	FMOPT1	FMOPT1	0xF41B	
Test Array Signature Register	TSTSIG	FMTST_SIG	FM_TSTSIG	FMTST_SIG		0xF41D		
							<b>x = A (n=0) B (n=1) C (n=2) D (n=3)</b>	
GPIO	Pull-Up Enable Register	PUPEN	PUR	GPIOx_PUPEN	GPIOx_PUR	GPIO_x_PUR	0xF1n0	
	Data Register	DATA	DR	GPIOx_DATA	GPIOx_DR	GPIO_x_DR	0xF1n1	
	Data Direction Register	DDIR	DDR	GPIOx_DDIR	GPIOx_DDR	GPIO_x_DDR	0xF1n2	
	Peripheral Enable Register	PEREN	PER	GPIOx_PEREN	GPIOx_PER	GPIO_x_PER	0xF1n3	
	Interrupt Assert Register	IASSRT	IAR	GPIOx_IASSRT	GPIOx_IAR	GPIO_x_IAR	0xF1n4	
	Interrupt Enable Register	IEN	IENR	GPIOx_IEN	GPIOx_IENR	GPIO_x_IENR	0xF1n5	
	Interrupt Edge Polarity Register	IEPOL	IPOLR	GPIOx_IEPOL	GPIOx_IPOLR	GPIO_x_IPOLR	0xF1n6	
	Interrupt Pending Register	IPEND	IPR	GPIOx_IPEND	GPIOx_IPR	GPIO_x_IPR	0xF1n7	
	Interrupt Edge Sensitive Register	IEDGE	IESR	GPIOx_IEDGE	GPIOx_IESR	GPIO_x_IESR	0xF1n8	
	Push-Pull Output Mode Control Register	PPOUTM	PPMODE	GPIOx_PPOUTM	GPIOx_PPMODE	GPIO_x_PPMODE	0xF1n9	
	Raw Data Register	RDATA	RAWDATA	GPIOx_RDATA	GPIOx_RAWDATA	GPIO_x_RAWDATA	0xF1nA	
	Drive Strength Control Register	DRIVE	DRIVE	GPIOx_DRIVE	GPIOx_DRIVE	GPIO_x_DRIVE	0xF1nB	
PS	Control Register	CTRL	LVICONTROL	PS_CTRL	LVICONTROL	LVICTRL	0xF160	
	Status Register	STAT	LVISTATUS	PS_STAT	LVISTATUS	LVISR	0xF161	
PWM	Control Register	CTRL	PMCTL	PWM_CTRL	PWM_PMCTL	PWM_PMCTL	0xF040	
	Fault Control Register	FCTRL	PMFCTL	PWM_FCTRL	PWM_PMFCTL	PWM_PMFCTL	0xF041	
	Fault Status/Acknowledge Regis.	FLTACK	PMFSA	PWM_FLTACK	PWM_PMFSA	PWM_PMFSA	0xF042	
	Output Control Register	OUT	PMOUT	PWM_OUT	PWM_PMOUT	PWM_PMOUT	0xF043	
	Counter Register	CNTR	PMCNT	PWM_CNTR	PWM_PMCNT	PWM_PMCNT	0xF044	
	Counter Modulo Register	CMOD	MCM	PWM_CMOD	PWM_MCM	PWM_PWMCM	0xF045	
	Value Register 0-5	VAL0-5	PMVAL0-5	PWM_VAL0-5	PWM_PMVAL0-5	PWM_PWMVAL0-5	0xF046	0xF04B
	Deadtime Register 0-1	DTIM0-1	PMDEADTM0-1	PWM_DTIM0-1	PWM_PMDEADTM0-1	PWM_PMDEADTM0-1	0xF04C	0xF04D
	Disable Mapping Register 1-2	DMAP1-2	PMDISMAP1-2	PWM_DMAP1-2	PWM_PMDISMAP1-2	PWM_PMDISMAP1-2	0xF04E	0xF04F
	Configure Register	CNFG	PMCFG	PWM_CNFG	PWM_PMCFG	PWM_PMCFG	0xF050	
	Channel Control Register	CCTRL	PMCCR	PWM_CCTRL	PWM_PMCCR	PWM_PMCCR	0xF051	
	Port Register	PORT	PMPORT	PWM_PORT	PWM_PMPORT	PWM_PMPORT	0xF052	
	Internal Correction Control Regis.	ICCTRL	PMICCR	PWM_ICCTRL	PWM_PMICCR	PWM_PMICCR	0xF053	
Source Control Register	SCTRL	PMSRC	PWM_SCTRL	PWM_PMSRC	PWM_PMSRC	0xF054		
SCI	Baud Rate Register	RATE	SCIBR	SCI_RATE	SCI_SCIBR	SCI_SCIBR	0xF0B0	
	Control Register 1	CTRL1	SCICR	SCI_CTRL1	SCI_SCICR	SCI_SCICR	0xF0B1	
	Control Register 2	CTRL2	SCICR2	SCI_CTRL2	SCI_SCICR2	SCI_SCICR2	0xF0B2	
	Status Register	STAT	SCISR	SCI_STAT	SCI_SCISR	SCI_SCISR	0xF0B3	
	Data Register	DATA	SCIDR	SCI_DATA	SCI_SCIDR	SCI_SCIDR	0xF0B4	
Module	Register Name	Peripheral Reference Manual		Data Sheet		Processor Expert Acronym	Memory Address	
		New Acronym	Legacy Acronym	New Acronym	Legacy Acronym		Start	End

<b>SIM</b>	Control Register	N/A	N/A	SIM_CTRL	SIM_CONTROL	SIM_CONTROL	0xF140
	Reset Status Register	N/A	N/A	SIM_RSTAT	SIM_RSTSTS	SIM_RSTSTS	0xF141
	Software Control Register 0-3	N/A	N/A	SIM_SWC0-3	SIM_SCR0-3	SIM_SCR0-3	0xF142   0xF145
	Most Significant Half JTAG ID	N/A	N/A	SIM_MSHID	SIM_MSH_ID	SIM_MSH_ID	0xF146
	Least Significant Half JTAG ID	N/A	N/A	SIM_LSHID	SIM_LSH_ID	SIM_LSH_ID	0xF147
	Power Control Register	N/A	N/A	SIM_PWR	SIM_POWER		0xF148
	Clock Out Select Register	N/A	N/A	SIM_CLKOUT	SIM_CLKOSR	SIM_CLKOSR	0xF14A
	GPIO Peripheral Select Register	N/A	N/A	SIM_GPS	SIM_GPS	SIM_GPS	0xF14B
	Peripheral Clock Enable Register	N/A	N/A	SIM_PCE	SIM_PCE	SIM_PCE	0xF14C
	I/O Short Address Location High	N/A	N/A	SIM_IOSAHI	SIM_ISALH	SIM_ISALH	0xF14D
I/O Short Address Location Low	N/A	N/A	SIM_IOSALO	SIM_ISALL	SIM_ISALL	0xF14E	

<b>SPI</b>	Status and Control Register	SCTRL	SPSCR	SPI_SCTRL	SPI_SPSCR	SPI_SCR	0xF0C0
	Data Size and Control Register	DSCTRL	SPDSR	SPI_DSCTRL	SPI_SPDSR	SPI_DSR	0xF0C1
	Data Receive Register	DRCV	SPDRR	SPI_DRCV	SPI_SPDRR	SPI_DRR	0xF0C2
	Data Transmit Register	DXMIT	SPDTR	SPI_DXMIT	SPI_SPDTR	SPI_DTR	0xF0C3

							<i>n</i> = 0, 1, 2, 3
<b>TMR</b>	Compare Register 1	COMP1	TMRCMP1	TMR <sub><i>n</i></sub> _COMP1	TMR <sub><i>n</i></sub> _CMP1	TMR <sub><i>n</i></sub> _CMP1	0xF0n0
	Compare Register 2	COMP2	TMRCMP2	TMR <sub><i>n</i></sub> _COMP2	TMR <sub><i>n</i></sub> _CMP2	TMR <sub><i>n</i></sub> _CMP2	0xF0n1
	Capture Register	CAPT	TMRCAP	TMR <sub><i>n</i></sub> _CAPT	TMR <sub><i>n</i></sub> _CAP	TMR <sub><i>n</i></sub> _CAP	0xF0n2
	Load Register	LOAD	TMRLOAD	TMR <sub><i>n</i></sub> _LOAD	TMR <sub><i>n</i></sub> _LOAD	TMR <sub><i>n</i></sub> _LOAD	0xF0n3
	Hold Register	HOLD	TMRHOLD	TMR <sub><i>n</i></sub> _HOLD	TMR <sub><i>n</i></sub> _HOLD	TMR <sub><i>n</i></sub> _HOLD	0xF0n4
	Counter Register	CNTR	TMRCNTR	TMR <sub><i>n</i></sub> _CNTR	TMR <sub><i>n</i></sub> _CNTR	TMR <sub><i>n</i></sub> _CNTR	0xF0n5
	Control Register	CTRL	TMRCTRL	TMR <sub><i>n</i></sub> _CTRL	TMR <sub><i>n</i></sub> _CTRL	TMR <sub><i>n</i></sub> _CTRL	0xF0n6
	Status and Control Register	SCTRL	TMRSCR	TMR <sub><i>n</i></sub> _SCTRL	TMR <sub><i>n</i></sub> _SCR	TMR <sub><i>n</i></sub> _SCR	0xF0n7
	Comparator Load Register 1	CMPLD1	TMRCMPLD1	TMR <sub><i>n</i></sub> _CMPLD1	TMR <sub><i>n</i></sub> _CMPLD1	TMR <sub><i>n</i></sub> _CMPLD1	0xF0n8
	Comparator Load Register 2	CMPLD2	TMRCMPLD2	TMR <sub><i>n</i></sub> _CMPLD2	TMR <sub><i>n</i></sub> _CMPLD2	TMR <sub><i>n</i></sub> _CMPLD2	0xF0n9
	Comparator Status/Control Register	CSCTRL	TMRCOMSCR	TMR <sub><i>n</i></sub> _CSCTRL	TMR <sub><i>n</i></sub> _COMSCR	TMR <sub><i>n</i></sub> _COMSCR	0xF0nA



## **How to Reach Us:**

### **Home Page:**

www.freescale.com

### **E-mail:**

support@freescale.com

### **USA/Europe or Locations Not Listed:**

Freescale Semiconductor  
Technical Information Center, CH370  
1300 N. Alma School Road  
Chandler, Arizona 85224  
+1-800-521-6274 or +1-480-768-2130  
support@freescale.com

### **Europe, Middle East, and Africa:**

Freescale Halbleiter Deutschland GmbH  
Technical Information Center  
Schatzbogen 7  
81829 Muenchen, Germany  
+44 1296 380 456 (English)  
+46 8 52200080 (English)  
+49 89 92103 559 (German)  
+33 1 69 35 48 48 (French)  
support@freescale.com

### **Japan:**

Freescale Semiconductor Japan Ltd.  
Headquarters  
ARCO Tower 15F  
1-8-1, Shimo-Meguro, Meguro-ku,  
Tokyo 153-0064, Japan  
0120 191014 or +81 3 5437 9125  
support.japan@freescale.com

### **Asia/Pacific:**

Freescale Semiconductor Hong Kong Ltd.  
Technical Information Center  
2 Dai King Street  
Tai Po Industrial Estate  
Tai Po, N.T., Hong Kong  
+800 2666 8080  
support.asia@freescale.com

### **For Literature Requests Only:**

Freescale Semiconductor Literature Distribution Center  
P.O. Box 5405  
Denver, Colorado 80217  
1-800-441-2447 or 303-675-2140  
Fax: 303-675-2150  
LDCForFreescaleSemiconductor@hibbertgroup.com

Information in this document is provided solely to enable system and software implementers to use Freescale Semiconductor products. There are no express or implied copyright licenses granted hereunder to design or fabricate any integrated circuits or integrated circuits based on the information in this document.

Freescale Semiconductor reserves the right to make changes without further notice to any products herein. Freescale Semiconductor makes no warranty, representation or guarantee regarding the suitability of its products for any particular purpose, nor does Freescale Semiconductor assume any liability arising out of the application or use of any product or circuit, and specifically disclaims any and all liability, including without limitation consequential or incidental damages. "Typical" parameters that may be provided in Freescale Semiconductor data sheets and/or specifications can and do vary in different applications and actual performance may vary over time. All operating parameters, including "Typicals", must be validated for each customer application by customer's technical experts. Freescale Semiconductor does not convey any license under its patent rights nor the rights of others. Freescale Semiconductor products are not designed, intended, or authorized for use as components in systems intended for surgical implant into the body, or other applications intended to support or sustain life, or for any other application in which the failure of the Freescale Semiconductor product could create a situation where personal injury or death may occur. Should Buyer purchase or use Freescale Semiconductor products for any such unintended or unauthorized application, Buyer shall indemnify and hold Freescale Semiconductor and its officers, employees, subsidiaries, affiliates, and distributors harmless against all claims, costs, damages, and expenses, and reasonable attorney fees arising out of, directly or indirectly, any claim of personal injury or death associated with such unintended or unauthorized use, even if such claim alleges that Freescale Semiconductor was negligent regarding the design or manufacture of the part.



Freescale™ and the Freescale logo are trademarks of Freescale Semiconductor, Inc. All other product or service names are the property of their respective owners. This product incorporates SuperFlash® technology licensed from SST.

© Freescale Semiconductor, Inc. 2005. All rights reserved.