

[查询SN54LS125AFK供应商](#)

The SN54125, SN54126, SN74125, SN74126, and SN54LS126A are obsolete and are no longer supplied.

# SN54125, SN54126, SN54LS125A, SN54LS126A, SN74125, SN74126, SN74LS125A, SN74LS126A QUADRUPLE BUS BUFFERS WITH 3-STATE OUTPUTS

SDLS044A – DECEMBER 1983 – REVISED MARCH 2002

- Quad Bus Buffers
- 3-State Outputs
- Separate Control for Each Channel

## description

These bus buffers feature three-state outputs that, when enabled, have the low impedance characteristics of a TTL output with additional drive capability at high logic levels to permit driving heavily loaded bus lines without external pullup resistors. When disabled, both output transistors are turned off, presenting a high-impedance state to the bus so the output will act neither as a significant load nor as a driver. The '125 and 'LS125A devices' outputs are disabled when  $\bar{G}$  is high. The '126 and 'LS126A devices' outputs are disabled when G is low.

SN54125, SN54126, SN54LS125A,  
SN54LS126A . . . J OR W PACKAGE  
SN74125, SN74126 . . . N PACKAGE  
SN74LS125A, SN74LS126A . . . D, N, OR NS PACKAGE  
(TOP VIEW)

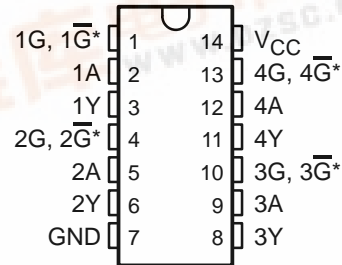

\* $\bar{G}$  on '125 and 'LS125A devices;  
G on 126 and 'LS126A devices

SN54LS125A, SN54LS126A . . . FK PACKAGE  
(TOP VIEW)

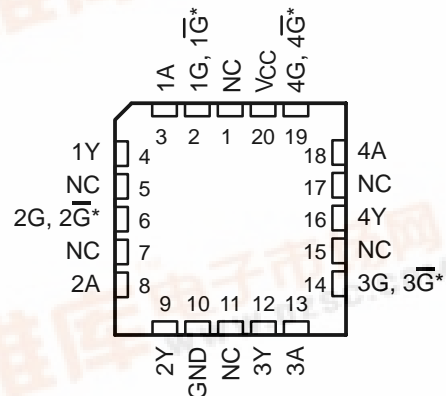

\* $\bar{G}$  on '125 and 'LS125A devices;  
G on 126 and 'LS126A devices  
NC – No internal connection

Please be aware that an important notice concerning availability, standard warranty, and use in critical applications of Texas Instruments semiconductor products and disclaimers thereto appears at the end of this data sheet.

PRODUCTION DATA information is current as of publication date. Products conform to specifications per the terms of Texas Instruments standard warranty. Production processing does not necessarily include testing of all parameters.

 **TEXAS  
INSTRUMENTS**

Copyright © 2002, Texas Instruments Incorporated  
On products compliant to MIL-PRF-38535, all parameters are tested unless otherwise noted. On all other products, production processing does not necessarily include testing of all parameters.

**SN54125, SN54126, SN54LS125A, SN54LS126A,  
SN74125, SN74126, SN74LS125A, SN74LS126A  
QUADRUPLE BUS BUFFERS WITH 3-STATE OUTPUTS**

SDLS044A – DECEMBER 1983 – REVISED MARCH 2002

The SN54125, SN54126, SN74125,  
SN74126, and SN54LS126A are  
obsolete and are no longer supplied.

**ORDERING INFORMATION**

T <sub>A</sub>	PACKAGE†		ORDERABLE PART NUMBER	TOP-SIDE MARKING
0°C to 70°C	PDIP – N	Tube	SN74LS125AN	SN74LS125AN
		Tube	SN74LS126AN	SN74LS126AN
	SOIC – D	Tube	SN74LS125AD	LS125A
		Tape and reel	SN74LS125ADR	
		Tube	SN74LS126AD	LS126A
	Tape and reel	SN74LS126ADR		
	SOP – NS	Tape and reel	SN74LS125ANSR	74LS125A
Tape and reel		SN74LS126ANSR	74LS126A	
–55°C to 125°C	CDIP – J	Tube	SN54LS125AJ	SN54LS125AJ
		Tube	SNJ54LS125AJ	SNJ54LS125AJ
	CFP – W	Tube	SNJ54LS125AW	SNJ54LS125AW
	LCCC – FK	Tube	SNJ54LS125AFK	SNJ54LS125AFK

† Package drawings, standard packing quantities, thermal data, symbolization, and PCB design guidelines are available at [www.ti.com/sc/package](http://www.ti.com/sc/package).

**logic diagram (each gate)**

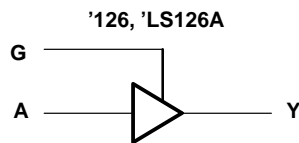
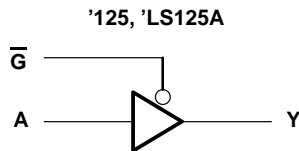

Y = A

The SN54125, SN54126, SN74125, SN74126, and SN54LS126A are obsolete and are no longer supplied.

**SN54125, SN54126, SN54LS125A, SN54LS126A, SN74125, SN74126, SN74LS125A, SN74LS126A**  
**QUADRUPLE BUS BUFFERS WITH 3-STATE OUTPUTS**  
 SDLS044A – DECEMBER 1983 – REVISED MARCH 2002

schematics (each gate)

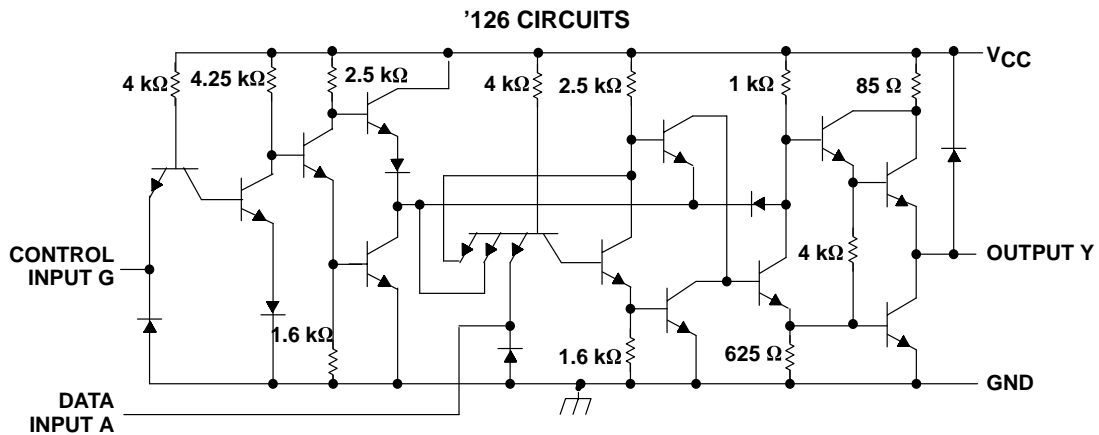
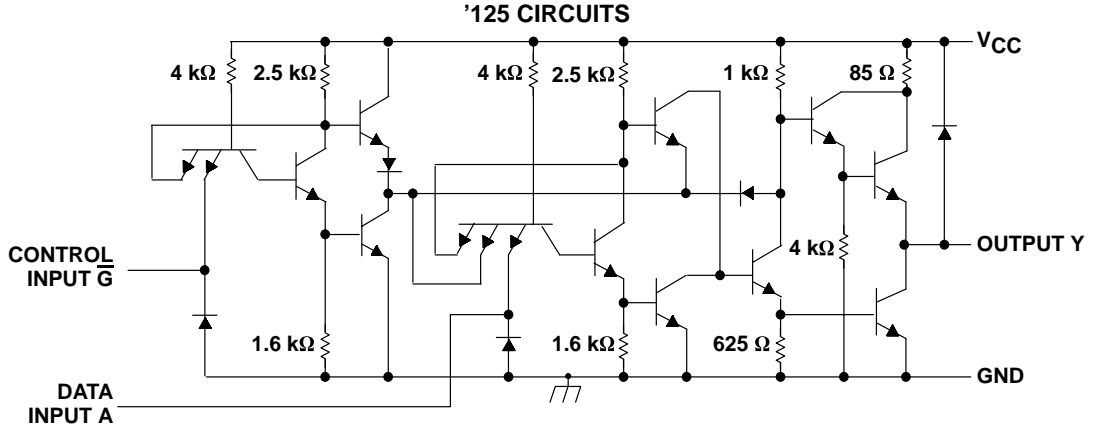

**absolute maximum ratings over operating free-air temperature (unless otherwise noted)†**  
 (‘125 and ‘126)

Supply voltage, $V_{CC}$ (see Note 1) .....	7 V
Input voltage, $V_I$ .....	5.5 V
Package thermal impedance, $\theta_{JA}$ (see Note 2): N package .....	80°C/W
Storage temperature range, $T_{Stg}$ .....	-65°C to 150°C

† Stresses beyond those listed under “absolute maximum ratings” may cause permanent damage to the device. These are stress ratings only, and functional operation of the device at these or any other conditions beyond those indicated under “recommended operating conditions” is not implied. Exposure to absolute-maximum-rated conditions for extended periods may affect device reliability.

- NOTES: 1. Voltage values are with respect to network ground terminal.  
 2. The package thermal impedance is calculated in accordance with JESD 51-7.

**SN54125, SN54126, SN54LS125A, SN54LS126A,  
SN74125, SN74126, SN74LS125A, SN74LS126A  
QUADRUPLE BUS BUFFERS WITH 3-STATE OUTPUTS**

SDLS044A – DECEMBER 1983 – REVISED MARCH 2002

The SN54125, SN54126, SN74125,  
SN74126, and SN54LS126A are  
obsolete and are no longer supplied.

**schematics (each gate)**

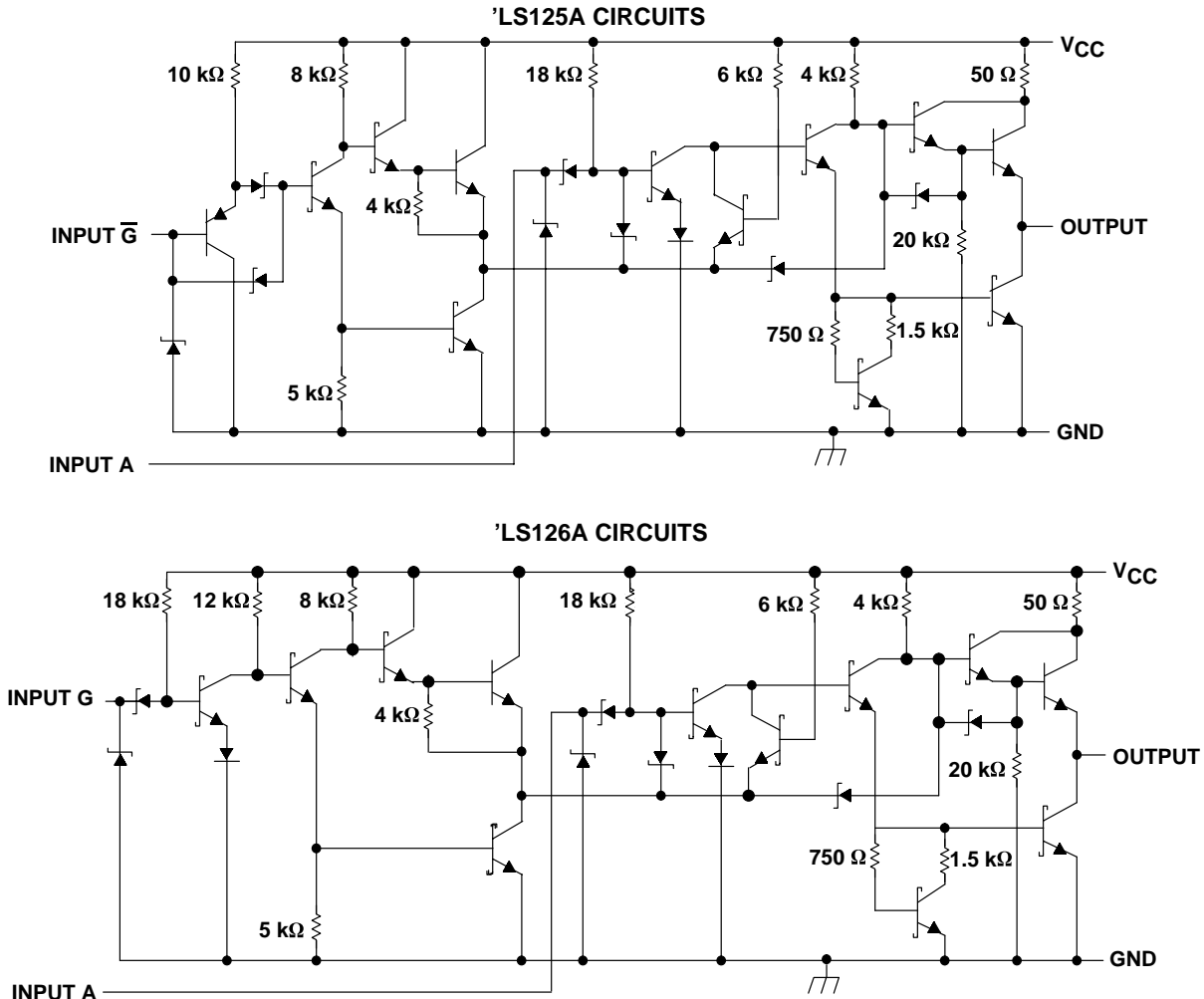

Resistor values shown are nominal.

**absolute maximum ratings over operating free-air temperature (unless otherwise noted)†  
(LS125A and LS126A)**

Supply voltage, $V_{CC}$ (see Note 1)	7 V
Input voltage, $V_I$	7 V
Package thermal impedance, $\theta_{JA}$ (see Note 2):	
D package	86°C/W
N package	80°C/W
NS package	76°C/W
Storage temperature range, $T_{stg}$	-65°C to 150°C

† Stresses beyond those listed under "absolute maximum ratings" may cause permanent damage to the device. These are stress ratings only, and functional operation of the device at these or any other conditions beyond those indicated under "recommended operating conditions" is not implied. Exposure to absolute-maximum-rated conditions for extended periods may affect device reliability.

- NOTES: 1. Voltage values are with respect to network ground terminal.  
2. The package thermal impedance is calculated in accordance with JESD 51-7.

The SN54125, SN54126, SN74125, SN74126, and SN54LS126A are obsolete and are no longer supplied.

**SN54125, SN54126, SN54LS125A, SN54LS126A,  
SN74125, SN74126, SN74LS125A, SN74LS126A  
QUADRUPLE BUS BUFFERS WITH 3-STATE OUTPUTS**  
SDLS044A – DECEMBER 1983 – REVISED MARCH 2002

**recommended operating conditions**

	SN54125 SN54126			SN74125 SN74126			UNIT
	MIN	NOM	MAX	MIN	NOM	MAX	
V <sub>CC</sub> Supply voltage	4.5	5	5.5	4.75	5	5.25	V
V <sub>IH</sub> High-level input voltage	2			2			V
V <sub>IL</sub> Low-level input voltage	0.8			0.8			V
I <sub>OH</sub> High-level output current	-2			-5.2			mA
I <sub>OL</sub> Low-level output current	16			16			mA
T <sub>A</sub> Operating free-air temperature	-55			0			70 °C

**electrical characteristics over recommended operating free-air temperature range (unless otherwise noted)**

PARAMETER	TEST CONDITIONS†		SN54125 SN54126			SN74125 SN74126			UNIT
			MIN	TYP‡	MAX	MIN	TYP‡	MAX	
V <sub>IK</sub>	V <sub>CC</sub> = MIN, I <sub>I</sub> = -12 mA		-1.5			-1.5			V
V <sub>OH</sub>	V <sub>CC</sub> = MIN, V <sub>IH</sub> = 2 V, V <sub>IL</sub> = 0.8 V	I <sub>OH</sub> = -2 mA	2.4	3.3				V	
		I <sub>OH</sub> = -5.2 mA			2.4	3.1			
V <sub>OL</sub>	V <sub>CC</sub> = MIN, V <sub>IH</sub> = 2 V, I <sub>OL</sub> = 16 mA	V <sub>IL</sub> = 0.8 V,	0.4			0.4			V
I <sub>OZ</sub>	V <sub>CC</sub> = MAX, V <sub>IH</sub> = 2 V, V <sub>IL</sub> = 0.8 V	V <sub>O</sub> = 2.4 V	40			40			μA
		V <sub>O</sub> = 0.4 V	-40			-40			
I <sub>I</sub>	V <sub>CC</sub> = MAX, V <sub>I</sub> = 6.5 V		1			1			mA
I <sub>IH</sub>	V <sub>CC</sub> = MAX, V <sub>I</sub> = 2.4 V		40			40			μA
I <sub>IL</sub>	V <sub>CC</sub> = MAX, V <sub>I</sub> = 0.4 V		-1.6			-1.6			mA
I <sub>OS</sub> §	V <sub>CC</sub> = MAX		-30	-70	-28	-70		mA	
I <sub>CC</sub>	V <sub>CC</sub> = MAX (see Note 3)	'125	32	54	32	54		mA	
		'126	36	62	36	62			

† For conditions shown as MIN or MAX, use the appropriate value specified under recommended operating conditions.

‡ All typical values are at V<sub>CC</sub> = 5 V, T<sub>A</sub> = 25°C.

§ Not more than one output should be shorted at a time.

NOTE 3: Data inputs = 0 V; output control = 4.5 V for '125 and 0 V for '126.

**switching characteristics, V<sub>CC</sub> = 5 V, T<sub>A</sub> = 25°C (see Figure 1)**

PARAMETER	TEST CONDITIONS		SN54125 SN74125			SN54126 SN74126			UNIT
			MIN	TYP	MAX	MIN	TYP	MAX	
t <sub>PLH</sub>	R <sub>L</sub> = 400 Ω, C <sub>L</sub> = 50 pF		8	13		8	13	ns	
t <sub>PHL</sub>			12	18		12	18		
t <sub>PZH</sub>	R <sub>L</sub> = 400 Ω, C <sub>L</sub> = 50 pF		11	17		11	18	ns	
t <sub>PZL</sub>			16	25		16	25		
t <sub>PHZ</sub>	R <sub>L</sub> = 400 Ω, C <sub>L</sub> = 5 pF		5	8		10	16	ns	
t <sub>PLZ</sub>			7	12		12	18		

**SN54125, SN54126, SN54LS125A, SN54LS126A,  
SN74125, SN74126, SN74LS125A, SN74LS126A  
QUADRUPLE BUS BUFFERS WITH 3-STATE OUTPUTS**

SDLS044A – DECEMBER 1983 – REVISED MARCH 2002

The SN54125, SN54126, SN74125,  
SN74126, and SN54LS126A are  
obsolete and are no longer supplied.

**recommended operating conditions**

		SN54LS125A SN54LS126A			SN74LS125A SN74LS126A			UNIT
		MIN	NOM	MAX	MIN	NOM	MAX	
V <sub>CC</sub>	Supply voltage	4.5	5	5.5	4.75	5	5.25	V
V <sub>IH</sub>	High-level input voltage	2			2			V
V <sub>IL</sub>	Low-level input voltage				0.7			V
I <sub>OH</sub>	High-level output current				-1			mA
I <sub>OL</sub>	Low-level output current				12			mA
T <sub>A</sub>	Operating free-air temperature	-55			125			°C

**electrical characteristics over recommended operating free-air temperature range (unless otherwise noted)**

PARAMETER	TEST CONDITIONS†		SN54LS125A SN54LS126A			SN74LS125A SN74LS126A			UNIT			
			MIN	TYP‡	MAX	MIN	TYP‡	MAX				
V <sub>IK</sub>	V <sub>CC</sub> = MIN, I <sub>I</sub> = -18 mA		-1.5			-1.5			V			
V <sub>OH</sub>	V <sub>CC</sub> = MIN, V <sub>IH</sub> = 2 V	V <sub>IL</sub> = 0.7 V, I <sub>OH</sub> = -1 mA	2.4						V			
		V <sub>IL</sub> = 0.8 V, I <sub>OH</sub> = -2.6 mA				2.4						
V <sub>OL</sub>	V <sub>CC</sub> = MIN, V <sub>IH</sub> = 2 V	V <sub>IL</sub> = 0.7 V, I <sub>OL</sub> = 12 mA	0.25		0.4				V			
		V <sub>IL</sub> = 0.8 V, I <sub>OL</sub> = 12 mA			0.25		0.4					
		V <sub>IL</sub> = 0.8 V, I <sub>OL</sub> = 24 mA			0.35		0.5					
I <sub>OZ</sub>	V <sub>CC</sub> = MAX, V <sub>IH</sub> = 2 V,	V <sub>IL</sub> = 0.7 V	V <sub>O</sub> = 2.4 V		20			μA				
			V <sub>O</sub> = 0.4 V		-20							
		V <sub>IL</sub> = 0.8 V	V <sub>O</sub> = 2.4 V		20							
			V <sub>O</sub> = 0.4 V		-20							
I <sub>I</sub>	V <sub>CC</sub> = MAX, V <sub>I</sub> = 7 V		0.1			0.1			mA			
I <sub>IH</sub>	V <sub>CC</sub> = MAX, V <sub>I</sub> = 2.7 V		20			20			μA			
I <sub>IL</sub>	V <sub>CC</sub> = MAX, V <sub>I</sub> = 0.4 V	'LS125A- $\bar{G}$ inputs		-0.2			-0.2			mA		
		'LS125A-A inputs; 'LS126A All inputs		-0.4			-0.4					
I <sub>OS</sub> §	V <sub>CC</sub> = MAX		-40		-225		-40		-225		mA	
I <sub>CC</sub>	V <sub>CC</sub> = MAX (see Note 4)	'LS125A		11		20		11		20		mA
		'LS126A		12		22		12		22		

† For conditions shown as MIN or MAX, use the appropriate value specified under recommended operating conditions.

‡ All typical values are at V<sub>CC</sub> = 5 V, T<sub>A</sub> = 25°C.

§ Not more than one output should be shorted at a time, and the duration of the short circuit should not exceed one second.

NOTE 4: Data inputs = 0 V; output control = 4.5 V for 'LS125A and 0 V for 'LS126A.

**switching characteristics, V<sub>CC</sub> = 5 V, T<sub>A</sub> = 25°C (see Figure 1)**

PARAMETER	TEST CONDITIONS		SN54LS125A SN74LS125A			SN54LS126A SN74LS126A			UNIT
			MIN	TYP	MAX	MIN	TYP	MAX	
t <sub>PLH</sub>	R <sub>L</sub> = 667 Ω, C <sub>L</sub> = 45 pF	9			15			ns	
t <sub>PHL</sub>		7			18				
t <sub>PZH</sub>	R <sub>L</sub> = 667 Ω, C <sub>L</sub> = 45 pF	12			20			ns	
t <sub>PZL</sub>		15			25				
t <sub>PHZ</sub>	R <sub>L</sub> = 667 Ω, C <sub>L</sub> = 5 pF				20			ns	
t <sub>PLZ</sub>					20				

The SN54125, SN54126, SN74125, SN74126, and SN54LS126A are obsolete and are no longer supplied.

SN54125, SN54126, SN54LS125A, SN54LS126A,  
SN74125, SN74126, SN74LS125A, SN74LS126A  
**QUADRUPLE BUS BUFFERS WITH 3-STATE OUTPUTS**  
SDLS044A – DECEMBER 1983 – REVISED MARCH 2002

**PARAMETER MEASUREMENT INFORMATION**  
**SERIES 54/74 DEVICES**

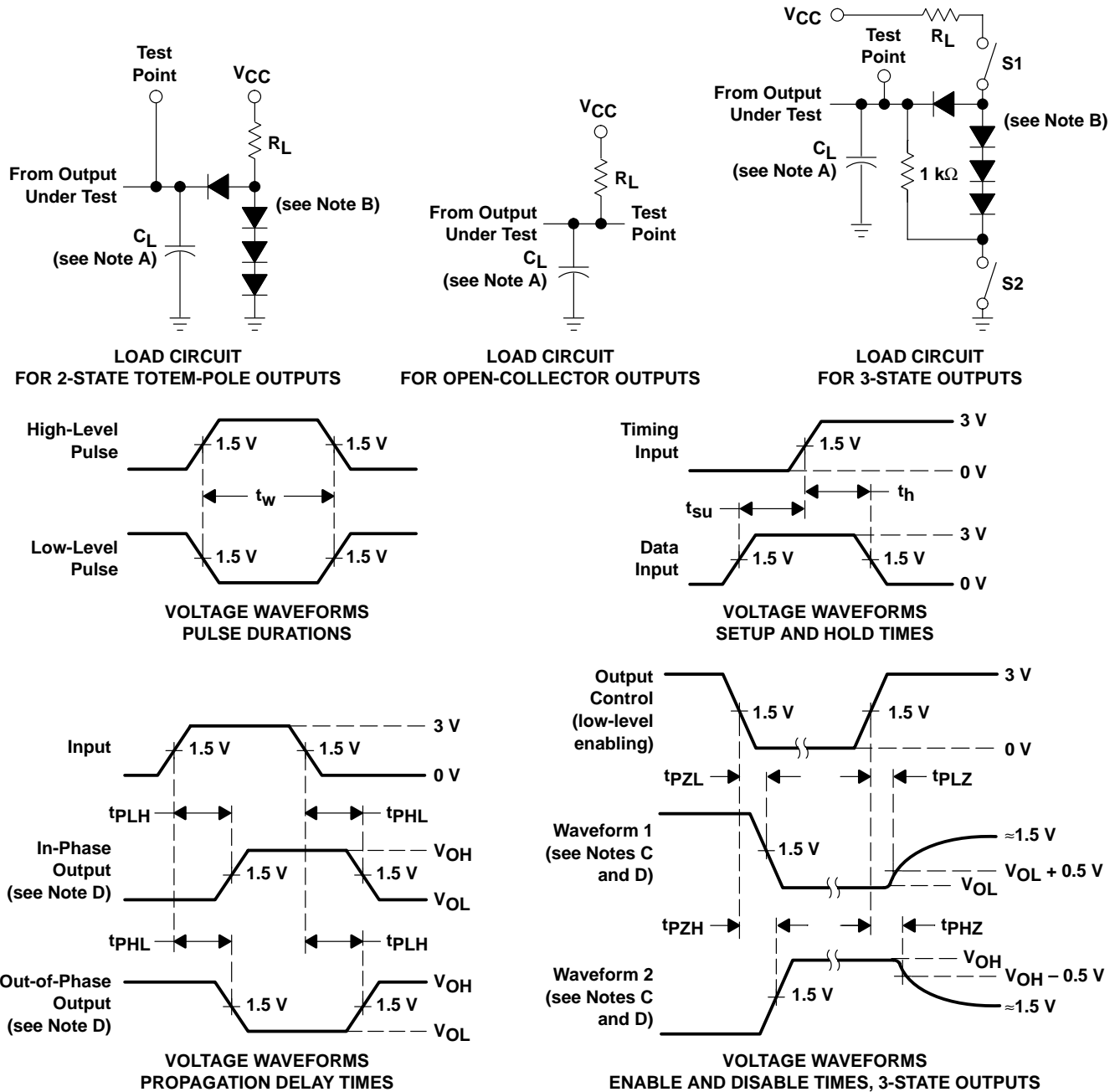

- NOTES: A.  $C_L$  includes probe and jig capacitance.  
B. All diodes are 1N3064 or equivalent.  
C. Waveform 1 is for an output with internal conditions such that the output is low except when disabled by the output control. Waveform 2 is for an output with internal conditions such that the output is high except when disabled by the output control.  
D. S1 and S2 are closed for  $t_{PLH}$ ,  $t_{PHL}$ ,  $t_{PHZ}$ , and  $t_{PLZ}$ ; S1 is open and S2 is closed for  $t_{PZH}$ ; S1 is closed and S2 is open for  $t_{PZL}$ .  
E. All input pulses are supplied by generators having the following characteristics:  $PRR \leq 1$  MHz,  $Z_O \approx 50 \Omega$ ;  $t_r$  and  $t_f \leq 7$  ns for Series 54/74 devices and  $t_r$  and  $t_f \leq 2.5$  ns for Series 54S/74S devices.  
F. The outputs are measured one at a time with one input transition per measurement.

Figure 1. Load Circuits and Voltage Waveforms

**SN54125, SN54126, SN54LS125A, SN54LS126A,  
SN74125, SN74126, SN74LS125A, SN74LS126A  
QUADRUPLE BUS BUFFERS WITH 3-STATE OUTPUTS**

SDLS044A – DECEMBER 1983 – REVISED MARCH 2002

The SN54125, SN54126, SN74125, SN74126, and SN54LS126A are obsolete and are no longer supplied.

**PARAMETER MEASUREMENT INFORMATION  
SERIES 54LS/74LS DEVICES**

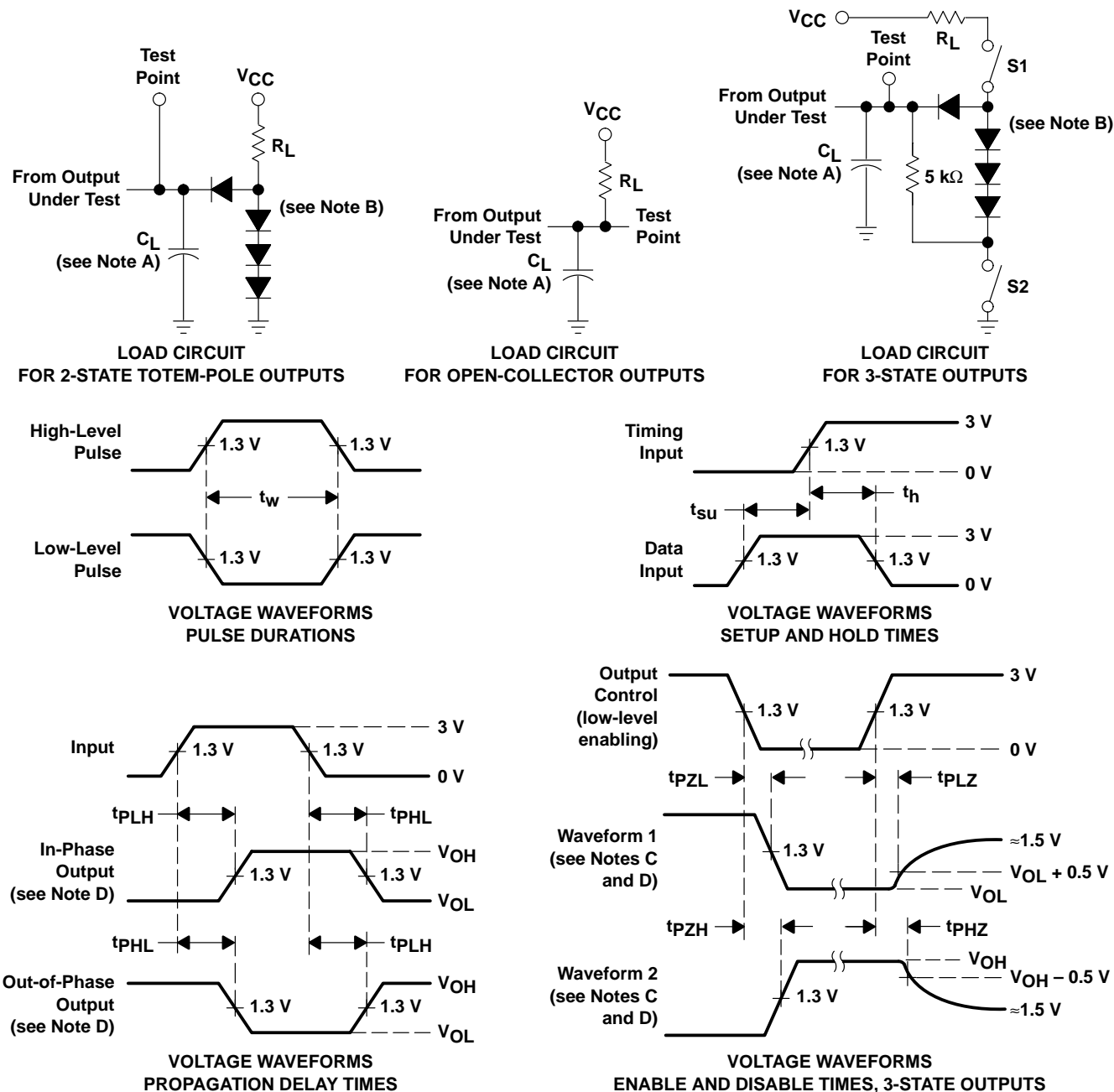

- NOTES: A.  $C_L$  includes probe and jig capacitance.  
 B. All diodes are 1N3064 or equivalent.  
 C. Waveform 1 is for an output with internal conditions such that the output is low except when disabled by the output control. Waveform 2 is for an output with internal conditions such that the output is high except when disabled by the output control.  
 D. S1 and S2 are closed for  $t_{PLH}$ ,  $t_{PHL}$ ,  $t_{PHZ}$ , and  $t_{PLZ}$ ; S1 is open and S2 is closed for  $t_{PZH}$ ; S1 is closed and S2 is open for  $t_{PZL}$ .  
 E. Phase relationships between inputs and outputs have been chosen arbitrarily for these examples.  
 F. All input pulses are supplied by generators having the following characteristics:  $PRR \leq 1$  MHz,  $Z_O \approx 50 \Omega$ ,  $t_r \leq 1.5$  ns,  $t_f \leq 2.6$  ns.  
 G. The outputs are measured one at a time with one input transition per measurement.

**Figure 2. Load Circuits and Voltage Waveforms**



## PACKAGING INFORMATION

Orderable Device	Status <sup>(1)</sup>	Package Type	Package Drawing	Pins	Package Qty	Eco Plan <sup>(2)</sup>	Lead/Ball Finish	MSL Peak Temp <sup>(3)</sup>
JM38510/32301B2A	ACTIVE	LCCC	FK	20	1	TBD	Call TI	Level-NC-NC-NC
JM38510/32301BCA	ACTIVE	CDIP	J	14	1	TBD	Call TI	Level-NC-NC-NC
JM38510/32301BDA	ACTIVE	CFP	W	14	1	TBD	Call TI	Level-NC-NC-NC
JM38510/32301SCA	ACTIVE	CDIP	J	14	1	TBD	Call TI	Level-NC-NC-NC
JM38510/32301SDA	ACTIVE	CFP	W	14	1	TBD	Call TI	Level-NC-NC-NC
SN54126J	OBSOLETE	CDIP	J	14		TBD	Call TI	Call TI
SN54LS125AJ	ACTIVE	CDIP	J	14	1	TBD	Call TI	Level-NC-NC-NC
SN74125N	OBSOLETE	PDIP	N	14		TBD	Call TI	Call TI
SN74125N3	OBSOLETE	PDIP	N	14		TBD	Call TI	Call TI
SN74126N	OBSOLETE	PDIP	N	14		TBD	Call TI	Call TI
SN74LS125AD	ACTIVE	SOIC	D	14	50	Green (RoHS & no Sb/Br)	CU NIPDAU	Level-1-260C-UNLIM
SN74LS125ADBR	ACTIVE	SSOP	DB	14	2000	Green (RoHS & no Sb/Br)	CU NIPDAU	Level-1-260C-UNLIM
SN74LS125ADBRE4	ACTIVE	SSOP	DB	14	2000	Green (RoHS & no Sb/Br)	CU NIPDAU	Level-1-260C-UNLIM
SN74LS125ADE4	ACTIVE	SOIC	D	14	50	Green (RoHS & no Sb/Br)	CU NIPDAU	Level-1-260C-UNLIM
SN74LS125ADR	ACTIVE	SOIC	D	14	2500	Green (RoHS & no Sb/Br)	CU NIPDAU	Level-1-260C-UNLIM
SN74LS125ADRE4	ACTIVE	SOIC	D	14	2500	Green (RoHS & no Sb/Br)	CU NIPDAU	Level-1-260C-UNLIM
SN74LS125AN	ACTIVE	PDIP	N	14	25	Pb-Free (RoHS)	CU NIPDAU	Level-NC-NC-NC
SN74LS125AN3	OBSOLETE	PDIP	N	14		TBD	Call TI	Call TI
SN74LS125ANE4	ACTIVE	PDIP	N	14	25	Pb-Free (RoHS)	CU NIPDAU	Level-NC-NC-NC
SN74LS125ANSR	ACTIVE	SO	NS	14	2000	Green (RoHS & no Sb/Br)	CU NIPDAU	Level-1-260C-UNLIM
SN74LS125ANSRE4	ACTIVE	SO	NS	14	2000	Green (RoHS & no Sb/Br)	CU NIPDAU	Level-1-260C-UNLIM
SN74LS125ANSRG4	ACTIVE	SO	NS	14	2000	Green (RoHS & no Sb/Br)	CU NIPDAU	Level-1-260C-UNLIM
SN74LS126AD	ACTIVE	SOIC	D	14	50	Green (RoHS & no Sb/Br)	CU NIPDAU	Level-1-260C-UNLIM
SN74LS126ADE4	ACTIVE	SOIC	D	14	50	Green (RoHS & no Sb/Br)	CU NIPDAU	Level-1-260C-UNLIM
SN74LS126ADR	ACTIVE	SOIC	D	14	2500	Green (RoHS & no Sb/Br)	CU NIPDAU	Level-1-260C-UNLIM
SN74LS126ADRE4	ACTIVE	SOIC	D	14	2500	Green (RoHS & no Sb/Br)	CU NIPDAU	Level-1-260C-UNLIM
SN74LS126AJ	OBSOLETE	CDIP	J	14		TBD	Call TI	Call TI
SN74LS126AN	ACTIVE	PDIP	N	14	25	Pb-Free (RoHS)	CU NIPDAU	Level-NC-NC-NC
SN74LS126ANE4	ACTIVE	PDIP	N	14	25	Pb-Free (RoHS)	CU NIPDAU	Level-NC-NC-NC
SN74LS126ANSR	ACTIVE	SO	NS	14	2000	Green (RoHS & no Sb/Br)	CU NIPDAU	Level-1-260C-UNLIM

Orderable Device	Status <sup>(1)</sup>	Package Type	Package Drawing	Pins	Package Qty	Eco Plan <sup>(2)</sup>	Lead/Ball Finish	MSL Peak Temp <sup>(3)</sup>
						no Sb/Br)		
SN74LS126ANSRE4	ACTIVE	SO	NS	14	2000	Green (RoHS & no Sb/Br)	CU NIPDAU	Level-1-260C-UNLIM
SNJ54126J	OBSOLETE	CDIP	J	14		TBD	Call TI	Call TI
SNJ54126W	OBSOLETE	CFP	W	14		TBD	Call TI	Call TI
SNJ54LS125AFK	ACTIVE	LCCC	FK	20	1	TBD	Call TI	Level-NC-NC-NC
SNJ54LS125AJ	ACTIVE	CDIP	J	14	1	TBD	Call TI	Level-NC-NC-NC
SNJ54LS125AW	ACTIVE	CFP	W	14	1	TBD	Call TI	Level-NC-NC-NC

<sup>(1)</sup> The marketing status values are defined as follows:

**ACTIVE:** Product device recommended for new designs.

**LIFEBUY:** TI has announced that the device will be discontinued, and a lifetime-buy period is in effect.

**NRND:** Not recommended for new designs. Device is in production to support existing customers, but TI does not recommend using this part in a new design.

**PREVIEW:** Device has been announced but is not in production. Samples may or may not be available.

**OBSOLETE:** TI has discontinued the production of the device.

<sup>(2)</sup> Eco Plan - The planned eco-friendly classification: Pb-Free (RoHS) or Green (RoHS & no Sb/Br) - please check <http://www.ti.com/productcontent> for the latest availability information and additional product content details.

**TBD:** The Pb-Free/Green conversion plan has not been defined.

**Pb-Free (RoHS):** TI's terms "Lead-Free" or "Pb-Free" mean semiconductor products that are compatible with the current RoHS requirements for all 6 substances, including the requirement that lead not exceed 0.1% by weight in homogeneous materials. Where designed to be soldered at high temperatures, TI Pb-Free products are suitable for use in specified lead-free processes.

**Green (RoHS & no Sb/Br):** TI defines "Green" to mean Pb-Free (RoHS compatible), and free of Bromine (Br) and Antimony (Sb) based flame retardants (Br or Sb do not exceed 0.1% by weight in homogeneous material)

<sup>(3)</sup> MSL, Peak Temp. -- The Moisture Sensitivity Level rating according to the JEDEC industry standard classifications, and peak solder temperature.

**Important Information and Disclaimer:**The information provided on this page represents TI's knowledge and belief as of the date that it is provided. TI bases its knowledge and belief on information provided by third parties, and makes no representation or warranty as to the accuracy of such information. Efforts are underway to better integrate information from third parties. TI has taken and continues to take reasonable steps to provide representative and accurate information but may not have conducted destructive testing or chemical analysis on incoming materials and chemicals. TI and TI suppliers consider certain information to be proprietary, and thus CAS numbers and other limited information may not be available for release.

In no event shall TI's liability arising out of such information exceed the total purchase price of the TI part(s) at issue in this document sold by TI to Customer on an annual basis.

J (R-GDIP-T\*\*)

14 LEADS SHOWN

CERAMIC DUAL IN-LINE PACKAGE

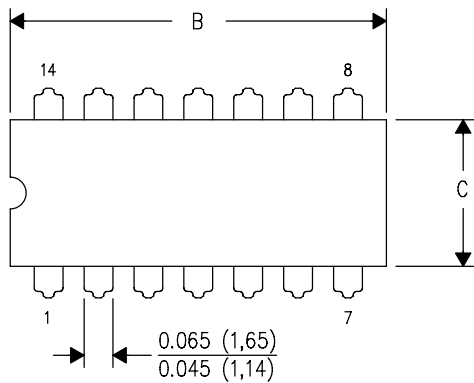

DIM \ PINS **	14	16	18	20
A	0.300 (7,62) BSC	0.300 (7,62) BSC	0.300 (7,62) BSC	0.300 (7,62) BSC
B MAX	0.785 (19,94)	.840 (21,34)	0.960 (24,38)	1.060 (26,92)
B MIN	—	—	—	—
C MAX	0.300 (7,62)	0.300 (7,62)	0.310 (7,87)	0.300 (7,62)
C MIN	0.245 (6,22)	0.245 (6,22)	0.220 (5,59)	0.245 (6,22)

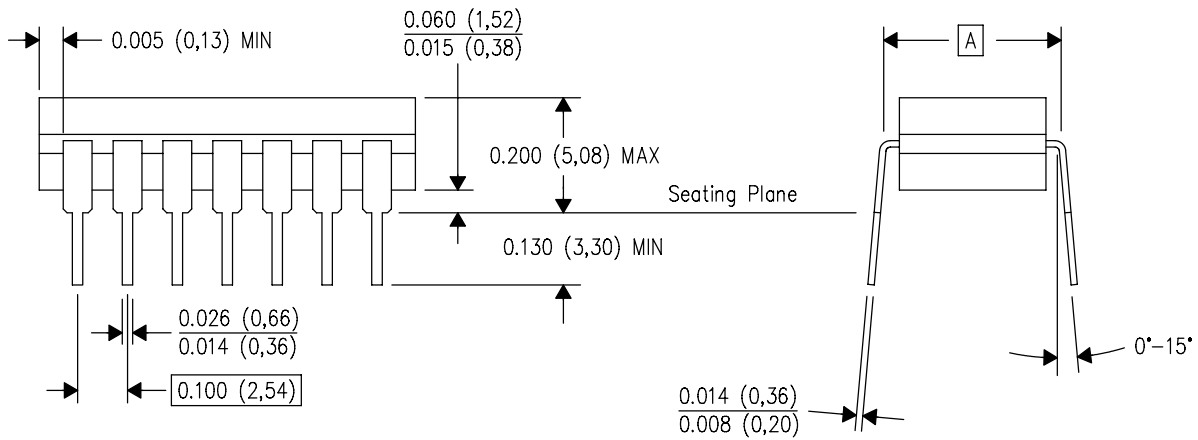

4040083/F 03/03

- NOTES:
- A. All linear dimensions are in inches (millimeters).
  - B. This drawing is subject to change without notice.
  - C. This package is hermetically sealed with a ceramic lid using glass frit.
  - D. Index point is provided on cap for terminal identification only on press ceramic glass frit seal only.
  - E. Falls within MIL STD 1835 GDIP1-T14, GDIP1-T16, GDIP1-T18 and GDIP1-T20.

# MECHANICAL DATA

W (R-GDFP-F14)

CERAMIC DUAL FLATPACK

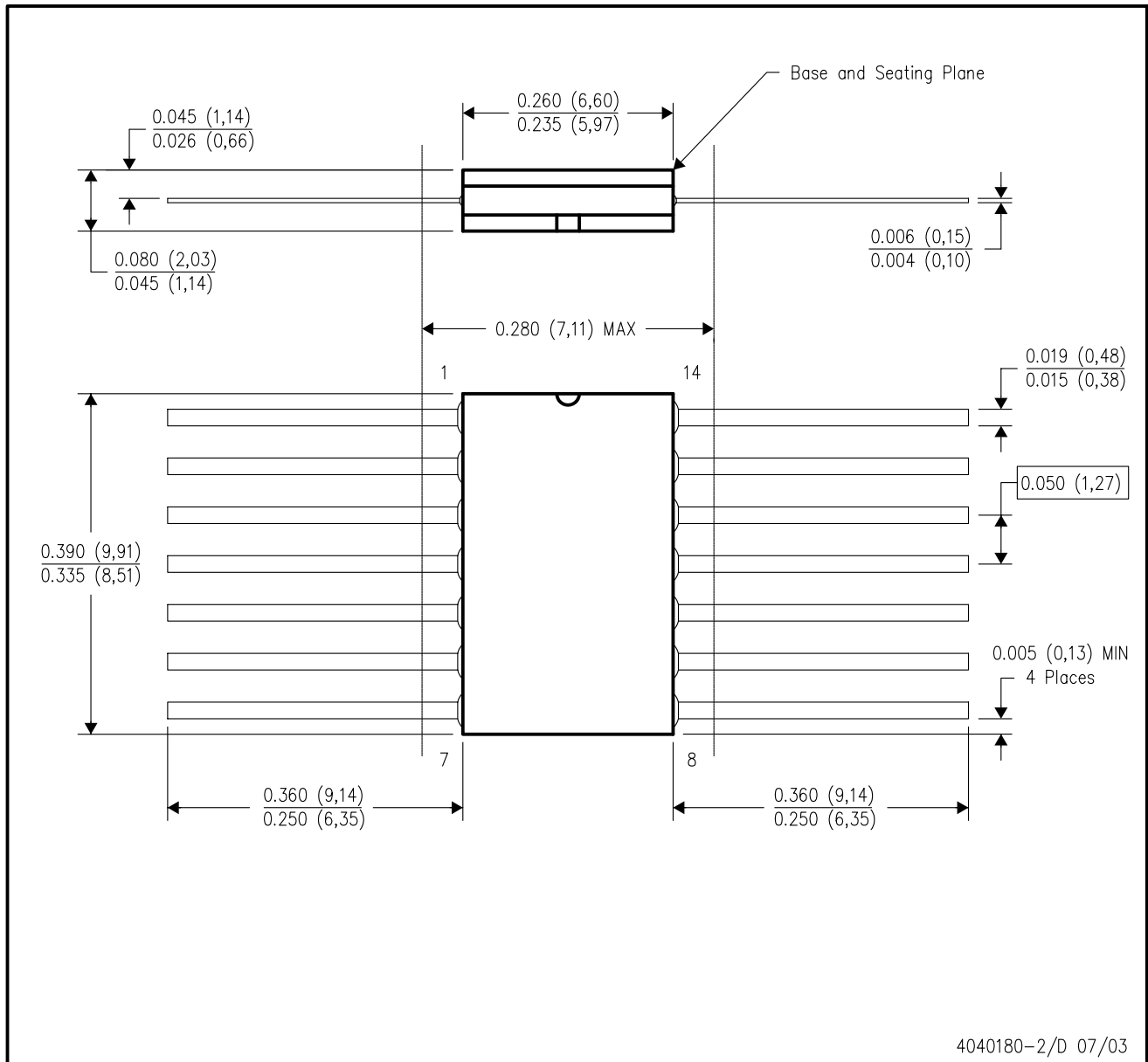

- NOTES:
- A. All linear dimensions are in inches (millimeters).
  - B. This drawing is subject to change without notice.
  - C. This package can be hermetically sealed with a ceramic lid using glass frit.
  - D. Index point is provided on cap for terminal identification only.
  - E. Falls within MIL STD 1835 GDFP1-F14 and JEDEC MO-092AB

# MECHANICAL DATA

MLCC006B – OCTOBER 1996

## FK (S-CQCC-N\*\*)

## LEADLESS CERAMIC CHIP CARRIER

28 TERMINAL SHOWN

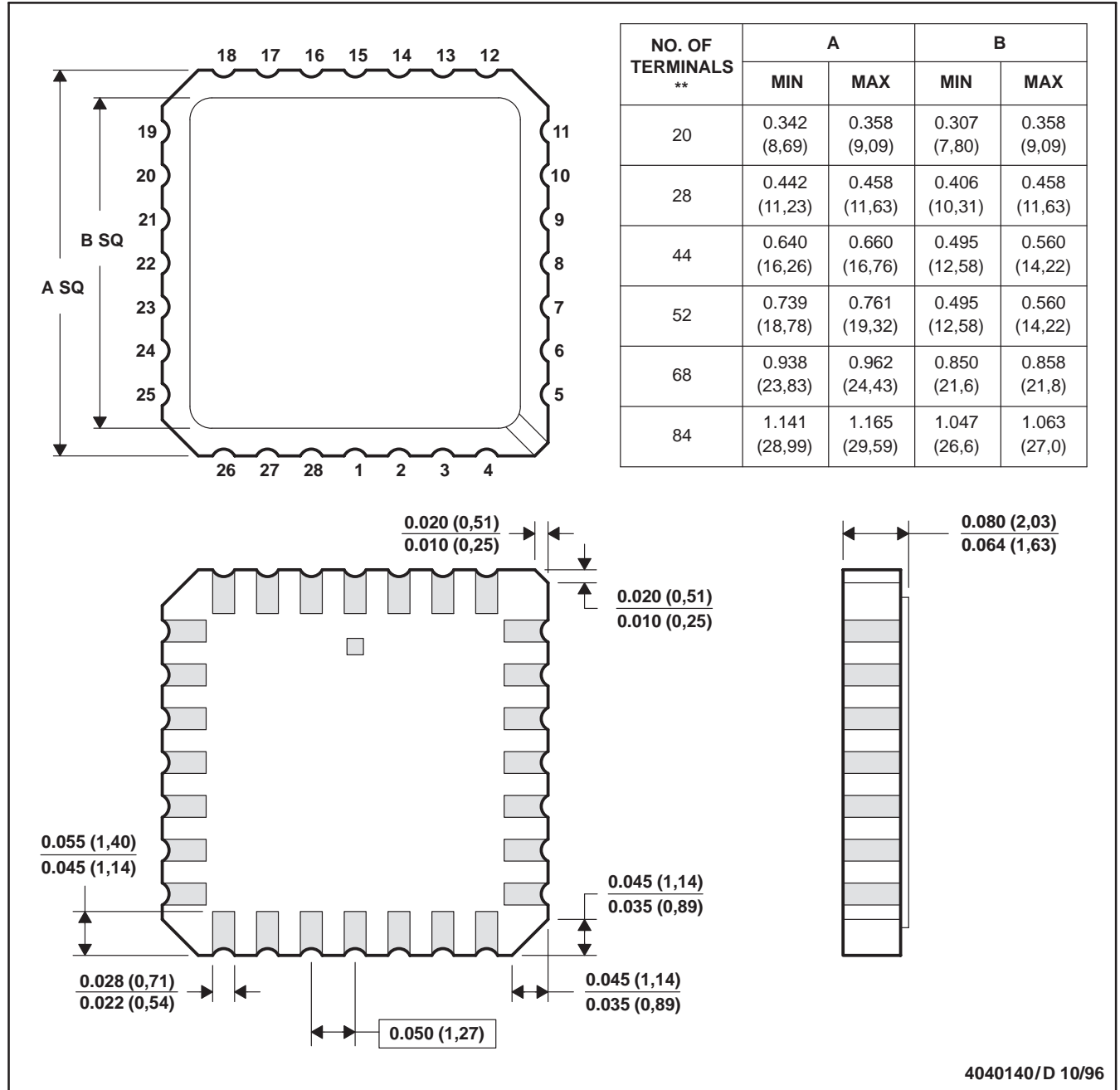

- NOTES:
- All linear dimensions are in inches (millimeters).
  - This drawing is subject to change without notice.
  - This package can be hermetically sealed with a metal lid.
  - The terminals are gold plated.
  - Falls within JEDEC MS-004

# MECHANICAL DATA

## N (R-PDIP-T\*\*)

## PLASTIC DUAL-IN-LINE PACKAGE

16 PINS SHOWN

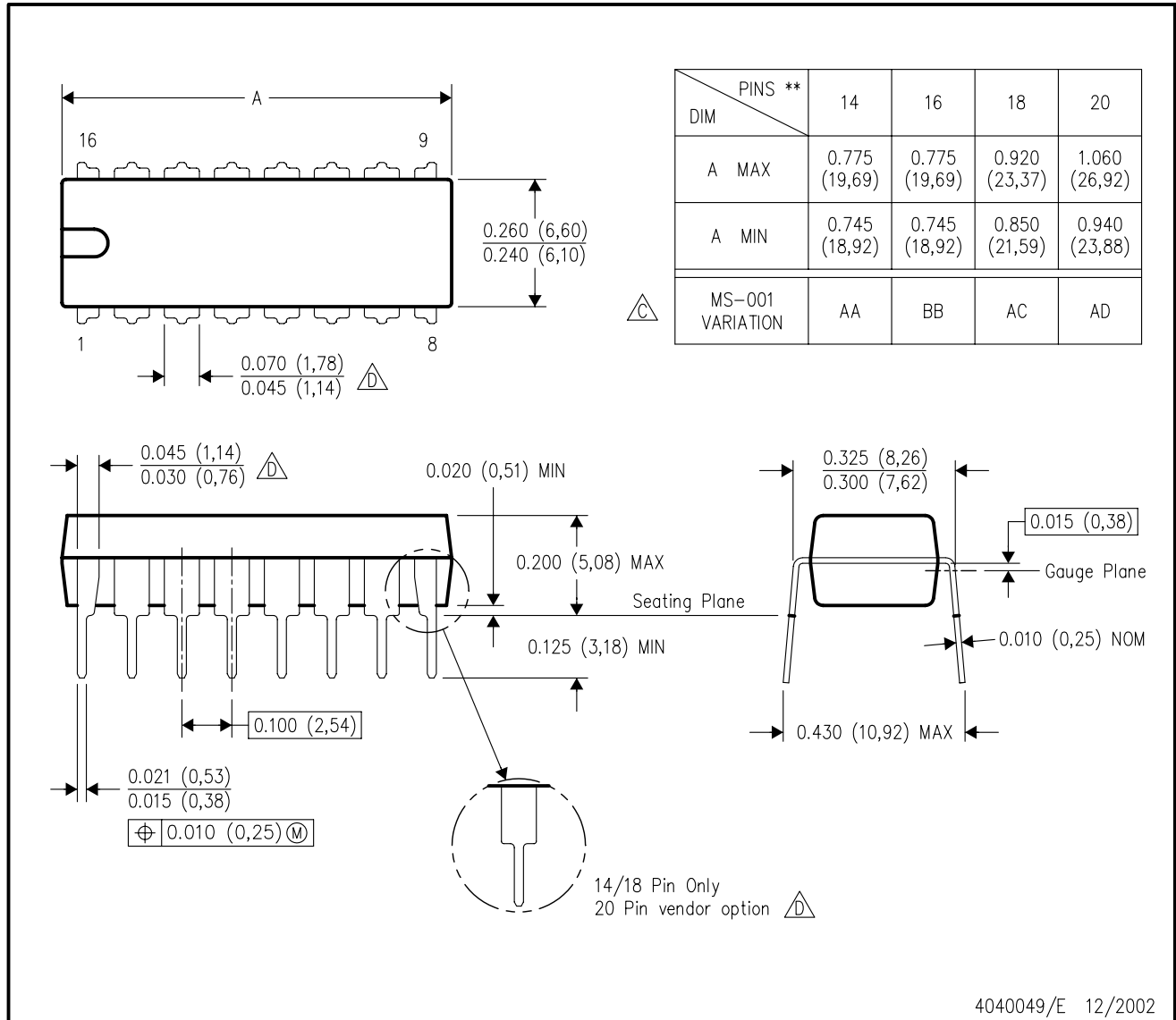

4040049/E 12/2002

- NOTES:
- A. All linear dimensions are in inches (millimeters).
  - B. This drawing is subject to change without notice.
  - Falls within JEDEC MS-001, except 18 and 20 pin minimum body length (Dim A).
  - The 20 pin end lead shoulder width is a vendor option, either half or full width.

# MECHANICAL DATA

## D (R-PDSO-G14)

## PLASTIC SMALL-OUTLINE PACKAGE

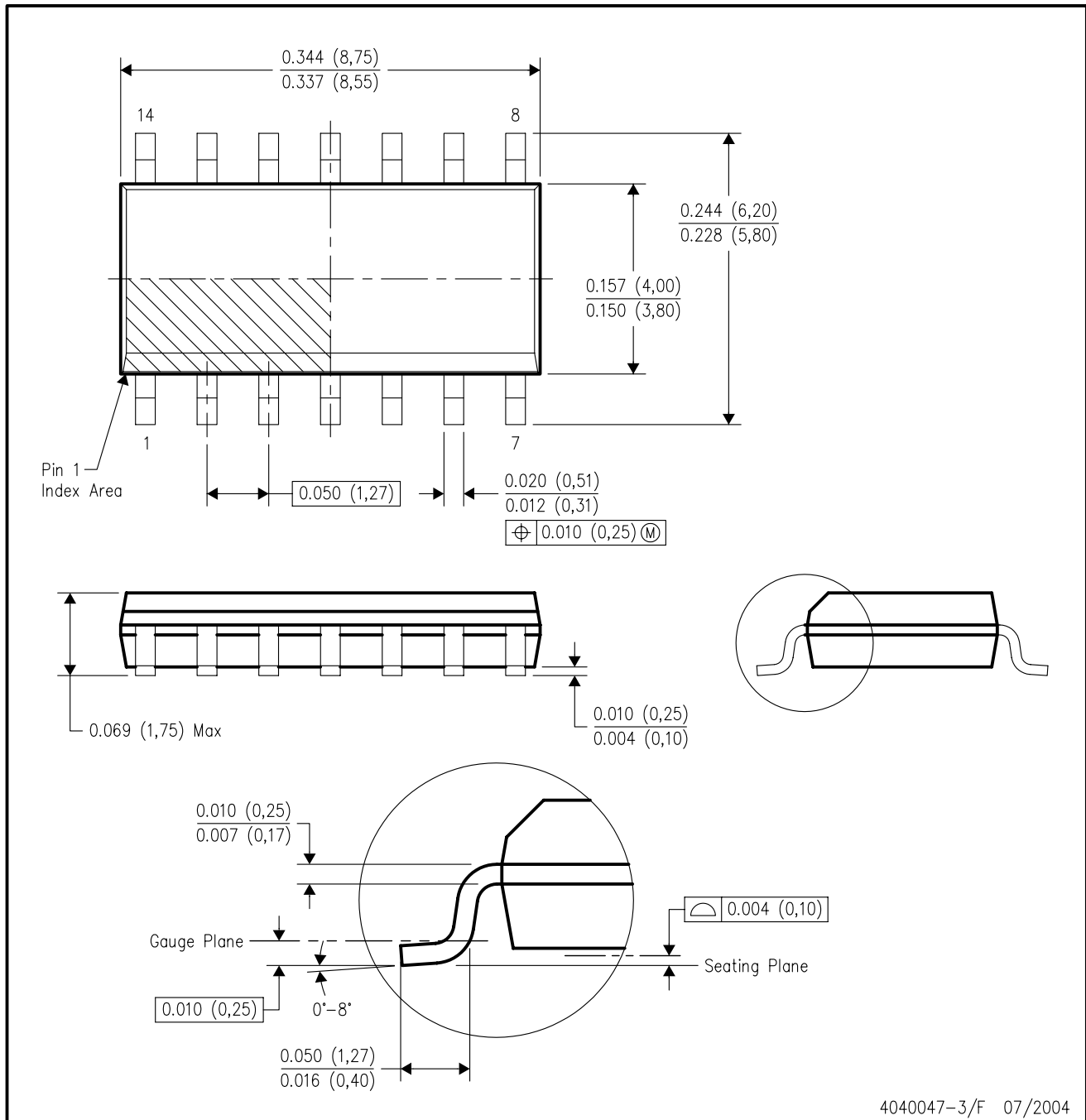

- NOTES:
- All linear dimensions are in inches (millimeters).
  - This drawing is subject to change without notice.
  - Body dimensions do not include mold flash or protrusion not to exceed 0.006 (0,15).
  - Falls within JEDEC MS-012 variation AB.

## MECHANICAL DATA

**NS (R-PDSO-G\*\*)**

**PLASTIC SMALL-OUTLINE PACKAGE**

**14-PINS SHOWN**

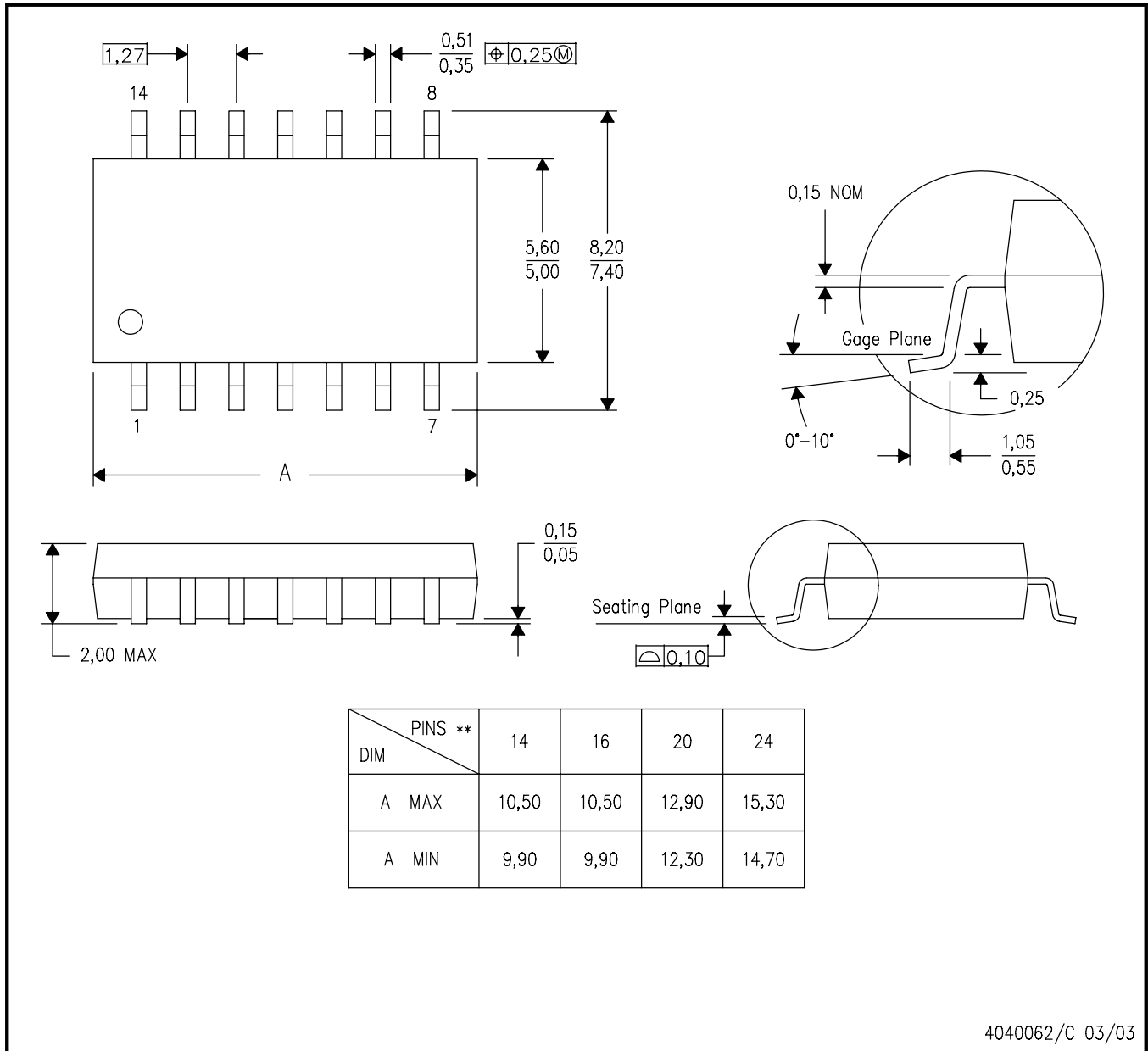

- NOTES:
- A. All linear dimensions are in millimeters.
  - B. This drawing is subject to change without notice.
  - C. Body dimensions do not include mold flash or protrusion, not to exceed 0,15.



# MECHANICAL DATA

MSS0002E – JANUARY 1995 – REVISED DECEMBER 2001

## DB (R-PDSO-G\*\*)

## PLASTIC SMALL-OUTLINE

28 PINS SHOWN

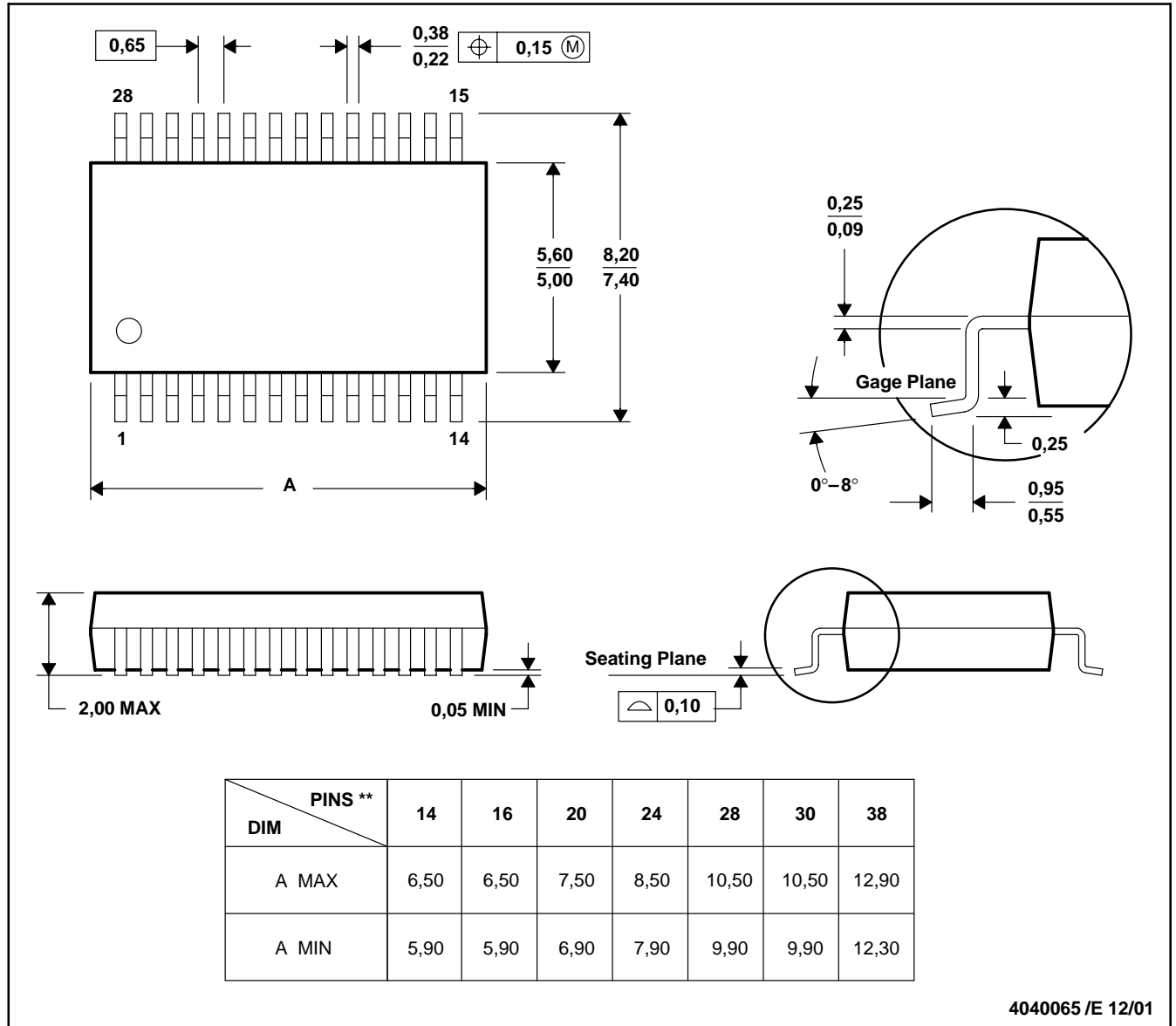

- NOTES: A. All linear dimensions are in millimeters.  
 B. This drawing is subject to change without notice.  
 C. Body dimensions do not include mold flash or protrusion not to exceed 0,15.  
 D. Falls within JEDEC MO-150

## IMPORTANT NOTICE

Texas Instruments Incorporated and its subsidiaries (TI) reserve the right to make corrections, modifications, enhancements, improvements, and other changes to its products and services at any time and to discontinue any product or service without notice. Customers should obtain the latest relevant information before placing orders and should verify that such information is current and complete. All products are sold subject to TI's terms and conditions of sale supplied at the time of order acknowledgment.

TI warrants performance of its hardware products to the specifications applicable at the time of sale in accordance with TI's standard warranty. Testing and other quality control techniques are used to the extent TI deems necessary to support this warranty. Except where mandated by government requirements, testing of all parameters of each product is not necessarily performed.

TI assumes no liability for applications assistance or customer product design. Customers are responsible for their products and applications using TI components. To minimize the risks associated with customer products and applications, customers should provide adequate design and operating safeguards.

TI does not warrant or represent that any license, either express or implied, is granted under any TI patent right, copyright, mask work right, or other TI intellectual property right relating to any combination, machine, or process in which TI products or services are used. Information published by TI regarding third-party products or services does not constitute a license from TI to use such products or services or a warranty or endorsement thereof. Use of such information may require a license from a third party under the patents or other intellectual property of the third party, or a license from TI under the patents or other intellectual property of TI.

Reproduction of information in TI data books or data sheets is permissible only if reproduction is without alteration and is accompanied by all associated warranties, conditions, limitations, and notices. Reproduction of this information with alteration is an unfair and deceptive business practice. TI is not responsible or liable for such altered documentation.

Resale of TI products or services with statements different from or beyond the parameters stated by TI for that product or service voids all express and any implied warranties for the associated TI product or service and is an unfair and deceptive business practice. TI is not responsible or liable for any such statements.

Following are URLs where you can obtain information on other Texas Instruments products and application solutions:

<b>Products</b>		<b>Applications</b>	
Amplifiers	<a href="http://amplifier.ti.com">amplifier.ti.com</a>	Audio	<a href="http://www.ti.com/audio">www.ti.com/audio</a>
Data Converters	<a href="http://dataconverter.ti.com">dataconverter.ti.com</a>	Automotive	<a href="http://www.ti.com/automotive">www.ti.com/automotive</a>
DSP	<a href="http://dsp.ti.com">dsp.ti.com</a>	Broadband	<a href="http://www.ti.com/broadband">www.ti.com/broadband</a>
Interface	<a href="http://interface.ti.com">interface.ti.com</a>	Digital Control	<a href="http://www.ti.com/digitalcontrol">www.ti.com/digitalcontrol</a>
Logic	<a href="http://logic.ti.com">logic.ti.com</a>	Military	<a href="http://www.ti.com/military">www.ti.com/military</a>
Power Mgmt	<a href="http://power.ti.com">power.ti.com</a>	Optical Networking	<a href="http://www.ti.com/opticalnetwork">www.ti.com/opticalnetwork</a>
Microcontrollers	<a href="http://microcontroller.ti.com">microcontroller.ti.com</a>	Security	<a href="http://www.ti.com/security">www.ti.com/security</a>
		Telephony	<a href="http://www.ti.com/telephony">www.ti.com/telephony</a>
		Video & Imaging	<a href="http://www.ti.com/video">www.ti.com/video</a>
		Wireless	<a href="http://www.ti.com/wireless">www.ti.com/wireless</a>

Mailing Address: Texas Instruments  
Post Office Box 655303 Dallas, Texas 75265