



# NEC's HIGH ISOLATION VOLTAGE 4-PIN SOP OPTOCOUPLER

PS2861-1

## FEATURES

- **ISOLATION DISTANCE:**  
0.4 mm MIN.
- **HIGH ISOLATION VOLTAGE:**  
BV = 2500 Vr.m.s.
- **SOP (SMALL OUT-LINE PACKAGE)**
- **HIGH SPEED SWITCHING:**  
tr = 4 μs TYP, tf = 5 μs TYP
- **AVAILABLE ON TAPE AND REEL**

## DESCRIPTION

NEC's PS2861-1 is an optically coupled isolator containing a GaAs light emitting diode and an NPN silicon phototransistor. This device's insulation thickness of 0.4 mm meets BS1's supplementary insulation requirements. This package is mounted in a plastic SOP (Small Out-line Package) for high density applications and has a shield effect to cut off ambient light.

## APPLICATIONS

- **MODEM**
- **PROGRAMMABLE LOGIC CONTROLLERS**
- **POWER SUPPLY**

## ELECTRICAL CHARACTERISTICS (TA = 25°C)

PART NUMBER			PS2861-1			
SYMBOLS	PARAMETERS	UNITS	MIN	TYP	MAX	
Diode	V <sub>F</sub>	Forward Voltage, I <sub>F</sub> = 5 mA	V	1.1	1.4	
	I <sub>R</sub>	Reverse Current, V <sub>R</sub> = 5 V	μA		5	
	C <sub>t</sub>	Terminal Capacitance, V = 0, f = 1 MHz	pF	15		
Transistor	I <sub>CEO</sub>	Collector to Emitter Dark Current, V <sub>CE</sub> = 40 V, I <sub>F</sub> = 0 mA	nA		100	
Coupled	CTR	Current Transfer Ratio (I <sub>c</sub> /I <sub>F</sub> ) <sup>1</sup> , I <sub>F</sub> = 5 mA, V <sub>CE</sub> = 5 V	%	50	200	400
	V <sub>CE (sat)</sub>	Collector Saturation Voltage, I <sub>F</sub> = 10 mA, I <sub>c</sub> = 2 mA	V			0.3
	R <sub>I-O</sub>	Isolation Resistance, V <sub>I-O</sub> = 1 kVDC	Ω	10 <sup>11</sup>		
	C <sub>I-O</sub>	Isolation Capacitance, V = 0, f = 1 MHz	pF		0.4	
	tr	Rise Time <sup>2</sup> , V <sub>CC</sub> = 5 V, I <sub>c</sub> = 2 mA, R <sub>L</sub> = 100 Ω	μs		4	
tf	Fall Time <sup>2</sup> , V <sub>CC</sub> = 5 V, I <sub>c</sub> = 2 mA, R <sub>L</sub> = 100 Ω	μs		5		

Notes:

- CTR Rank  
K: 200 to 400%  
M: 50 to 150%  
L: 100 to 300%  
N: 50 to 400%

### 2. Test Circuit for Switching Time

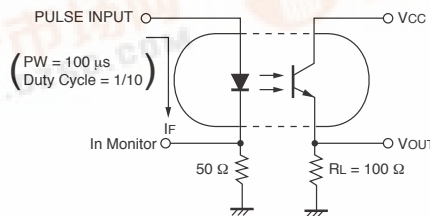

# PS2861-1

## ABSOLUTE MAXIMUM RATINGS<sup>1</sup> (T<sub>A</sub> = 25°C)

SYMBOLS	PARAMETERS	UNITS	RATINGS
<b>Diode</b>			
I <sub>F</sub>	Forward Current (DC)	mA	50
V <sub>R</sub>	Reverse Voltage	V	6
P <sub>D</sub>	Power Dissipation	mW	60
ΔP <sub>D</sub> /°C	Power Dissipation Derating	mW/°C	0.6
I <sub>F</sub> (PEAK)	Peak Forward Current <sup>2</sup>	A	0.5
<b>Transistor</b>			
V <sub>CEO</sub>	Collector to Emitter Voltage	V	40
V <sub>ECO</sub>	Emitter to Collector Voltage	V	5
I <sub>C</sub>	Collector Current	mA	40
P <sub>C</sub>	Power Dissipation	mW	120
ΔP <sub>C</sub> /°C	Power Dissipation Derating	mW/°C	1.2
<b>Coupled</b>			
BV	Isolation Voltage <sup>3</sup>	V <sub>r.m.s.</sub>	2500
T <sub>A</sub>	Operating Ambient Temp.	°C	-55 to +100
T <sub>STG</sub>	Storage Temperature	°C	-55 to +150

## ORDERING INFORMATION

PART NUMBER	PACKAGE	PACKING STYLE
PS2861-1	4-pin SOP	Magazine case 100 pcs
PS2861-1-F3		Embossed Tape 3500 pcs/reel
PS2861-1-F4		

### Notes:

1. Operation in excess of any one of these parameters may result in permanent damage.
2. PW = 100 μs, duty cycle = 1%.
3. AC voltage for 1 minute at T<sub>A</sub> = 25 °C, RH = 60 % between input and output.

## TYPICAL PERFORMANCE CURVES (T<sub>A</sub> = 25°C)

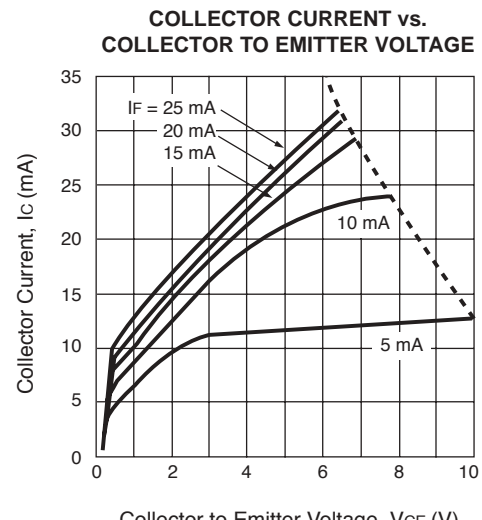
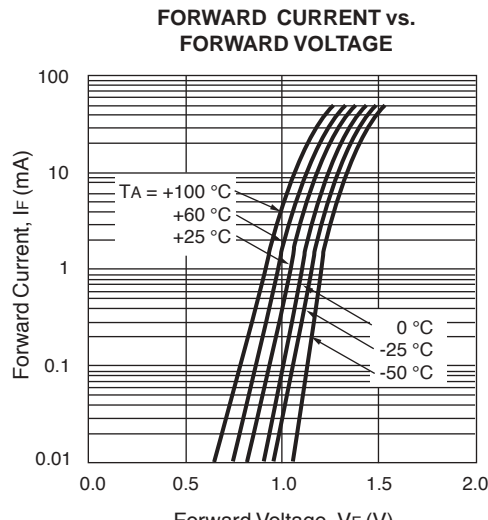
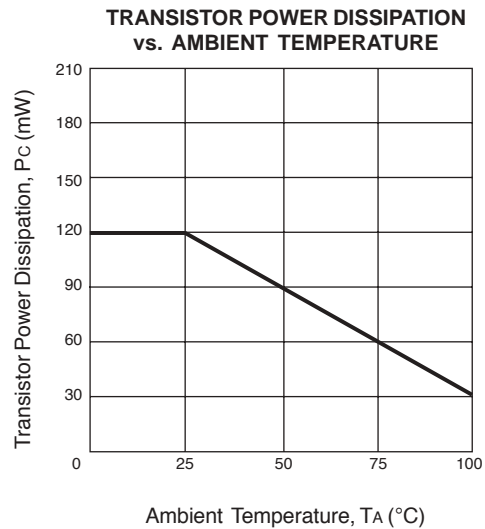
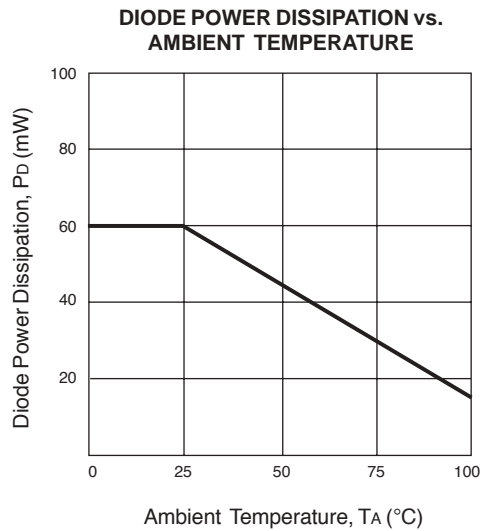

**TYPICAL PERFORMANCE CURVES** ( $T_A = 25^\circ\text{C}$ )

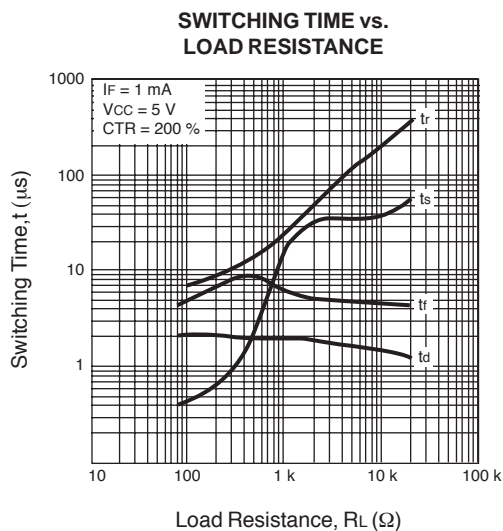
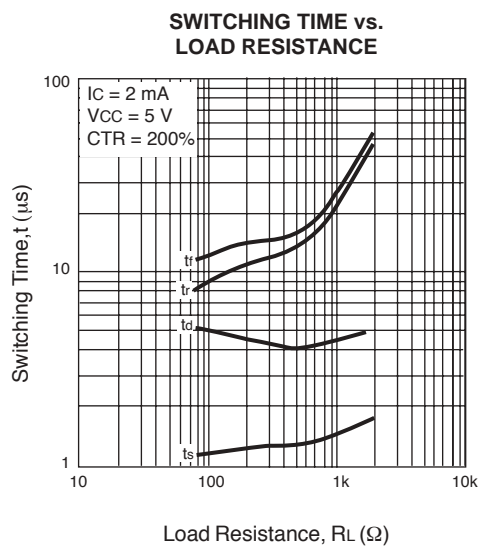
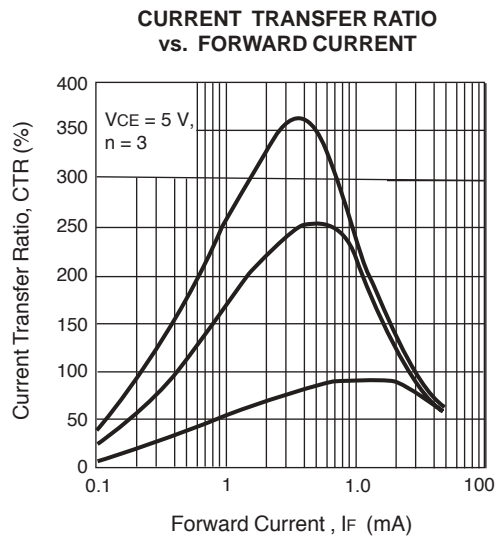
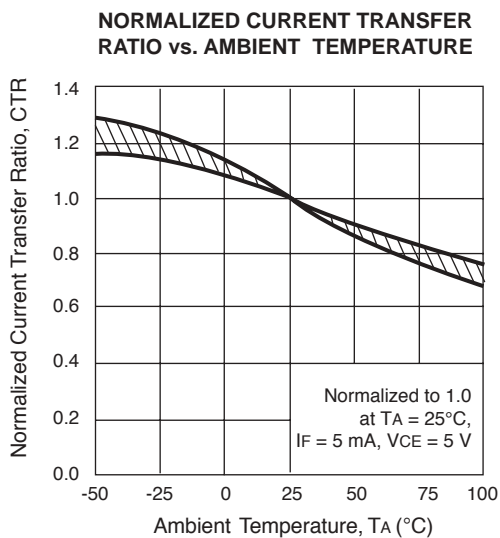
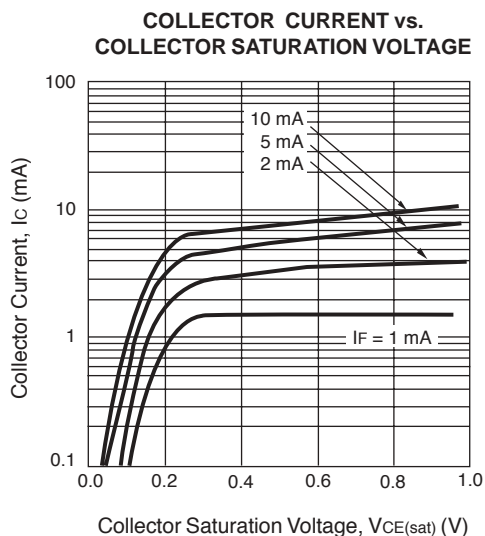
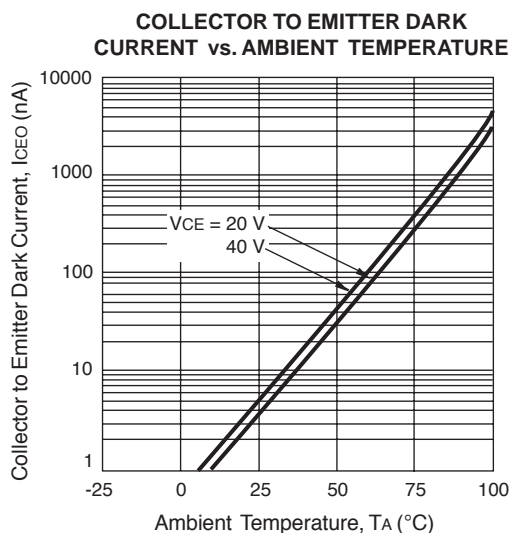

# PS2861-1

## TYPICAL PERFORMANCE CURVES (TA = 25°C)

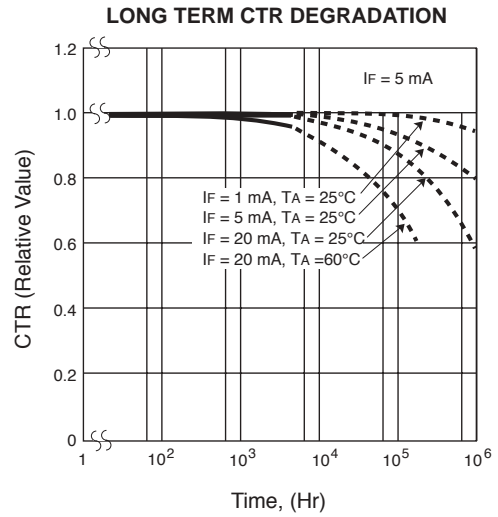
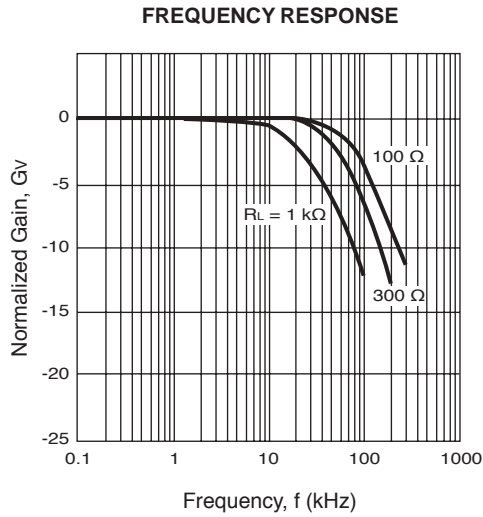

## PHOTOCOUPLER CONSTRUCTION

PARAMETER	UNIT (MIN)
Air Distance	4.5 mm
Creepage Distance	4.5 mm
Isolation Distance	0.4 mm

## OUTLINE DIMENSIONS (Units in mm)

PS2861-1

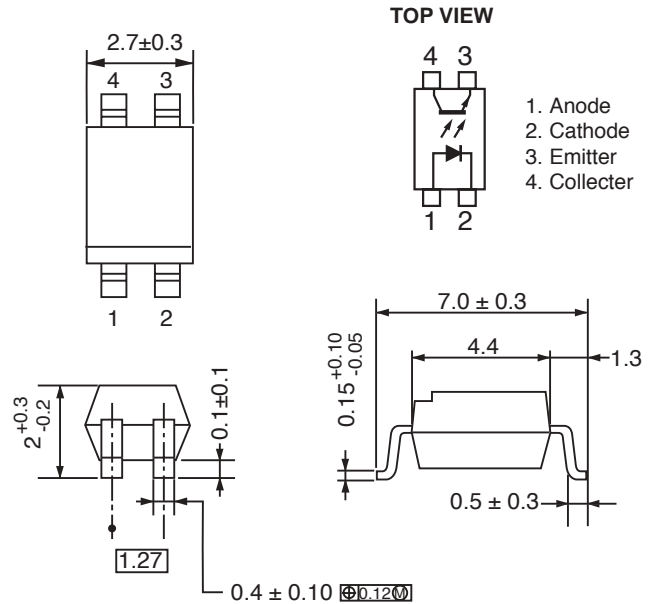

## MARKING

Last number of type No.: 61

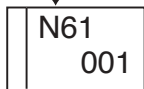

Assembly lot

0 01

Serial Code in week

Assembly Year

**TAPING SPECIFICATIONS** (Units in mm)

**OUTLINE AND DIMENSIONS (TAPE)**

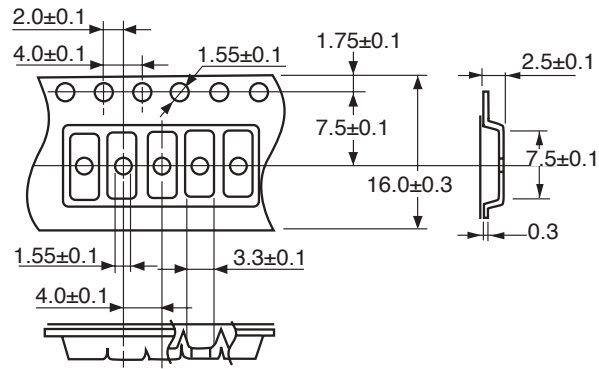

**TAPING DIRECTION**

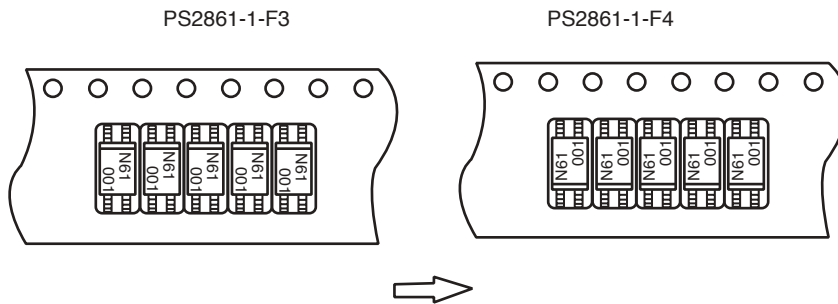

**OUTLINE AND DIMENSIONS (REEL)**

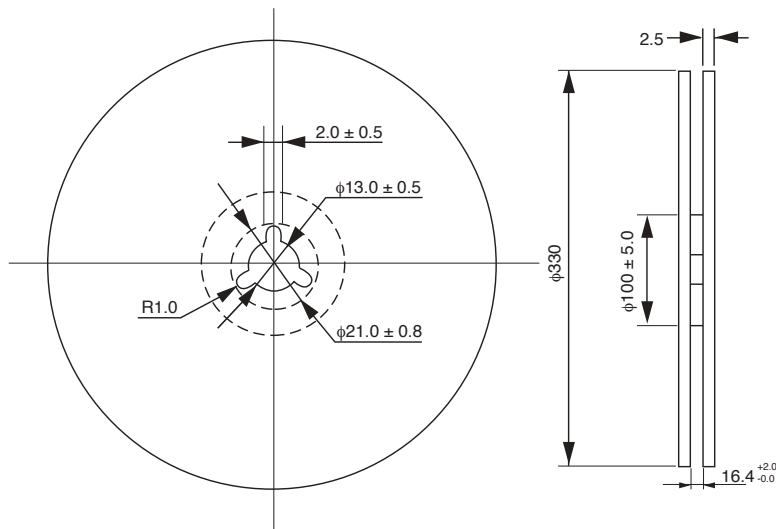

Packing: 3500 pcs/reel

## 1. Recommended Soldering Conditions

### (1) Infrared reflow soldering

- Peak reflow temperature 235 °C (package surface temperature)
- Time of temperature higher than 210 °C 30 seconds or less
- Number of reflows Three
- Flux Rosin flux containing small amount of chlorine (The flux with a maximum chlorine content of 0.2 Wt % is recommended).

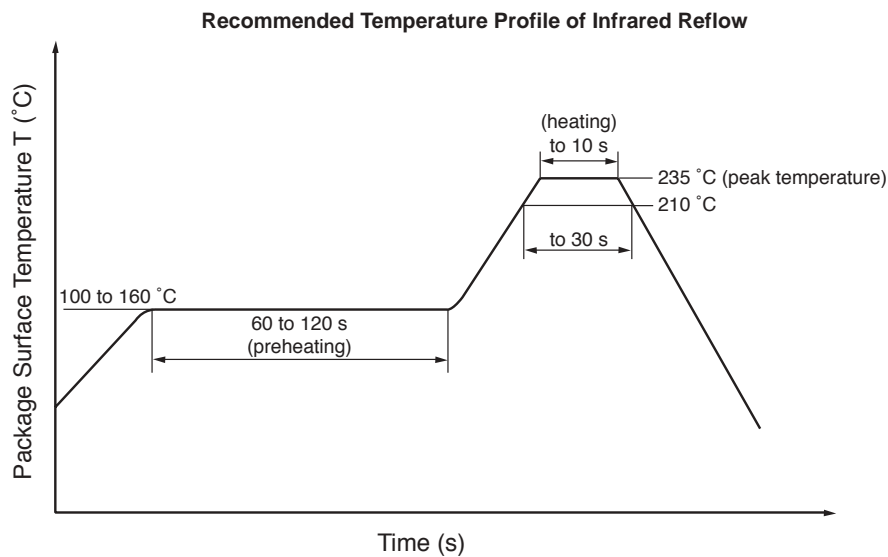

### (2) Dip soldering

- Temperature 260 °C or below (molten solder temperature)
- Time 10 seconds or less
- Number of times One (allowed to be dipped in solder including plastic mold portion)
- Flux Rosin flux containing small amount of chlorine (The flux with a maximum chlorine content of 0.2 Wt % is recommended).

### (3) Cautions

- Fluxes Avoid removing the residual flux with freon-based and chlorine-based cleaning solvent.

## 2. Cautions regarding noise

Be aware that when voltage is applied suddenly between the photocoupler's input and output or between collector -emitters at startup, the output side may enter the on state, even if the voltage is within the absolute maximum ratings.

#### Life Support Applications

These NEC products are not intended for use in life support devices, appliances, or systems where the malfunction of these products can reasonably be expected to result in personal injury. The customers of CEL using or selling these products for use in such applications do so at their own risk and agree to fully indemnify CEL for all damages resulting from such improper use or sale.