

6118

Data Sheet
29313D*

VACUUM FLUORESCENT DISPLAY DRIVER

A6118SLW

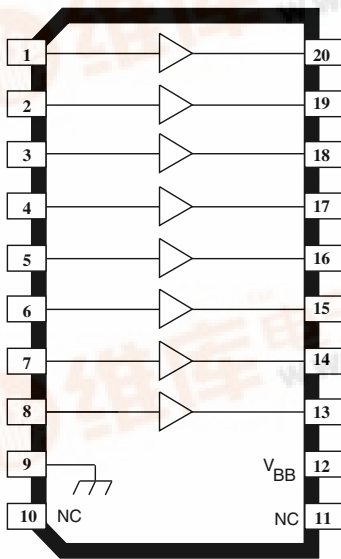

Dwg. PP-064-3

Consisting of eight npn Darlington output stages and the associated common-emitter input stages, these drivers are designed to interface between low-level digital logic and vacuum fluorescent displays. Both devices are capable of driving the digits and/or segments of these displays and are designed to permit all outputs to be activated simultaneously. Pull-down resistors are incorporated into each output and no external components are required for most fluorescent display applications.

With any device, the output load is activated when the input is pulled towards the positive supply (active 'high'). The UDN6118A is furnished in a standard 18-pin plastic DIP; the A6118SLW is in a 20-lead wide-body SOIC. Both units operate over the temperature range of -20°C to +85°C. These devices are also available for operation over the temperature range of -40°C to +85°C by changing the part number to UDQ6118A or A6118ELW.

FEATURES

- Digit or Segment Drivers
- Low Input Current
- Integral Output Pull-Down Resistors
- High Output Breakdown Voltage
- Single or Split Supply Operation
- Automotive Capable

ABSOLUTE MAXIMUM RATINGS at T_A = +25°C

Supply Voltage, V _{BB}	85 V
Input Voltage, V _{IN}	20 V
Output Current, I _{OUT}	-40 mA
Allowable Package Power Dissipation, P _D	See Graph
Operating Temperature Range, T _A	-20°C to +85°C
Storage Temperature Range, T _S	-55°C to +150°C

Caution: The high input impedance of these devices makes them susceptible to static discharge damage associated with handling and testing. Techniques similar to those used for handling MOS devices should be employed.

Always order by complete part number, e.g., **UDN6118A**.



6118 VACUUM FLUORESCENT DISPLAY DRIVER

UDN6118A

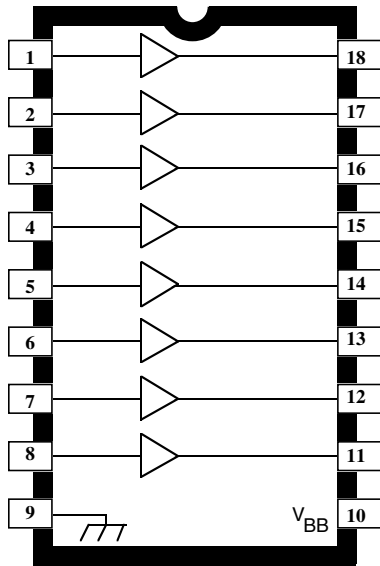

Dwg. PP-065

**PARTIAL SCHEMATIC
ONE DRIVER (ALL TYPES)**

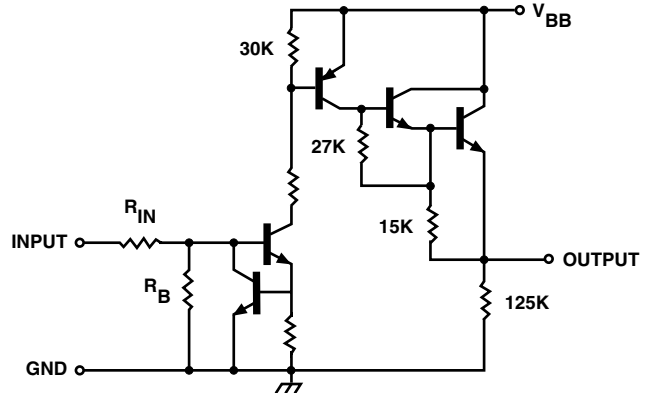

Dwg. No. A-10,592C

R _{IN}	R _B
10 kΩ	30 kΩ

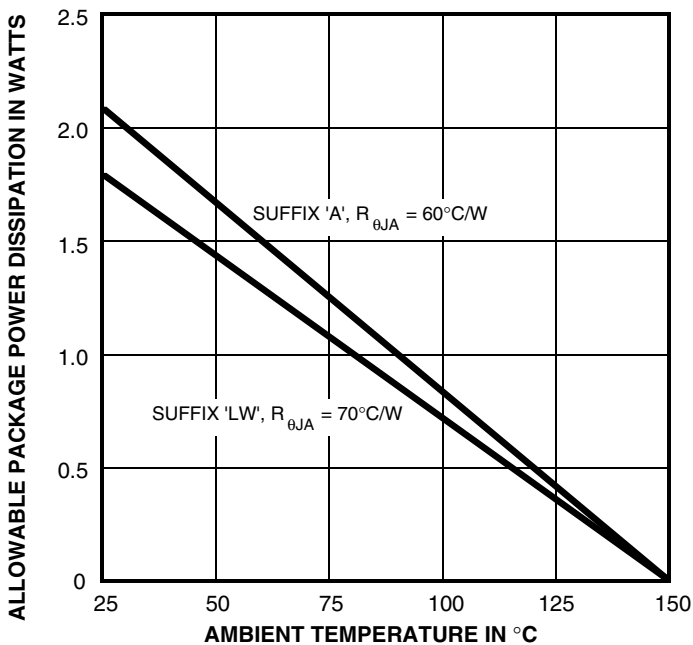

Dwg. GS-009-1

6118
VACUUM FLUORESCENT
DISPLAY DRIVER

ELECTRICAL CHARACTERISTICS (over operating temperature range) at $V_{BB} = 80\text{ V}$.

Characteristic	Symbol	Test Conditions	Limits			
			Min.	Typ.	Max.	Units
Output Leakage Current	I_{OUT}	$V_{IN} = 0.4\text{ V}$	—	—	15	μA
Output OFF Voltage	V_{OUT}	$V_{IN} = 0.4\text{ V}$	—	—	1.0	V
Output Pull-Down Current	I_{OUT}	Input Open, $V_{OUT} = V_{BB}$	450	650	1100	μA
Output ON Voltage	V_{OUT}	$V_{IN} = 2.4\text{ V}$, $I_{OUT} = -25\text{ mA}$	77	78	—	V
Input ON Current	I_{IN}	$V_{IN} = 2.4\text{ V}$	—	120	225	μA
		$V_{IN} = 5.0\text{ V}$	—	375	650	μA
Supply Current	I_{BB}	All Inputs Open	—	10	100	μA
		All Inputs = 2.4 V	—	6.0	9.0	mA

RECOMMENDED OPERATING CONDITIONS

Characteristic	Symbol	Test Conditions	Limits			
			Min.	Typ.	Max.	Units
Supply Voltage	V_{BB}		5.0	—	70	V
Input ON Voltage	V_{IN}		2.4	—	15	V
Output ON Current	I_{OUT}		—	—	-25	mA

NOTE: Positive (negative) current is defined as going into (coming out of) the specified device terminal.

6118 VACUUM FLUORESCENT DISPLAY DRIVER

TYPICAL MULTIPLEXED FLUORESCENT DISPLAY

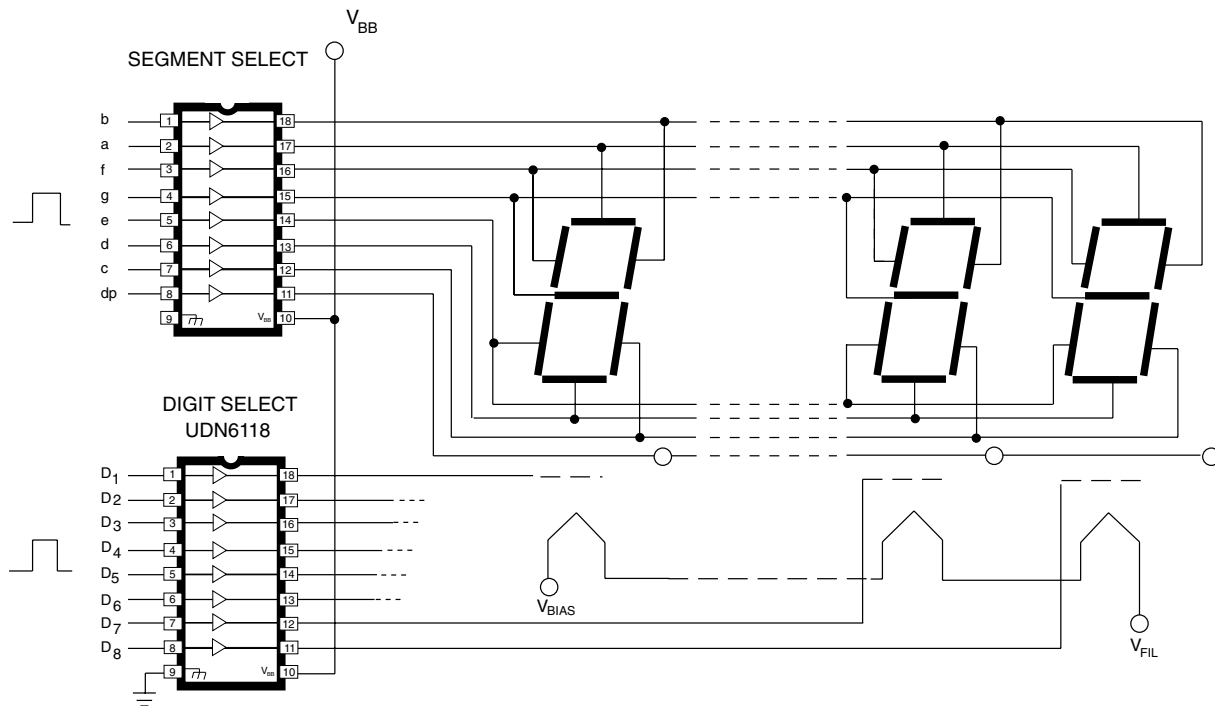

Dwg. No. A-10,261B

6118 VACUUM FLUORESCENT DISPLAY DRIVER

UDN6118A

Dimensions in Inches
(controlling dimensions)

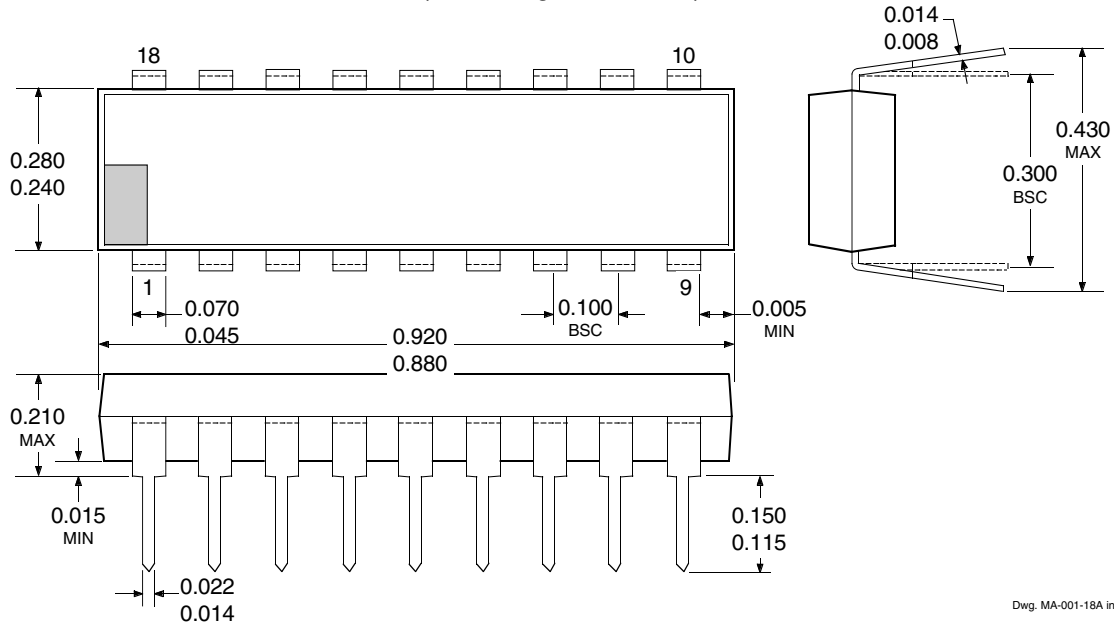

Dimensions in Millimeters
(for reference only)

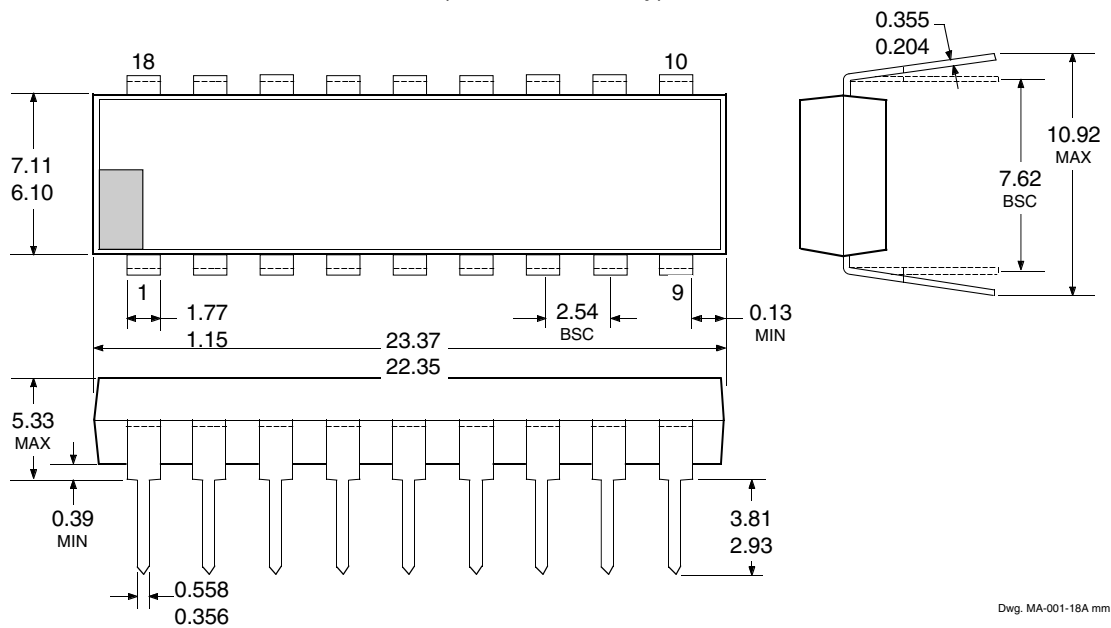

- NOTES: 1. Exact body and lead configuration at vendor's option within limits shown.
 2. Lead spacing tolerance is non-cumulative.
 3. Lead thickness is measured at seating plane or below.
 4. Supplied in standard sticks/tubes of 21 devices.

6118 VACUUM FLUORESCENT DISPLAY DRIVER

A6118SLW

Dimensions in Inches
(for reference only)

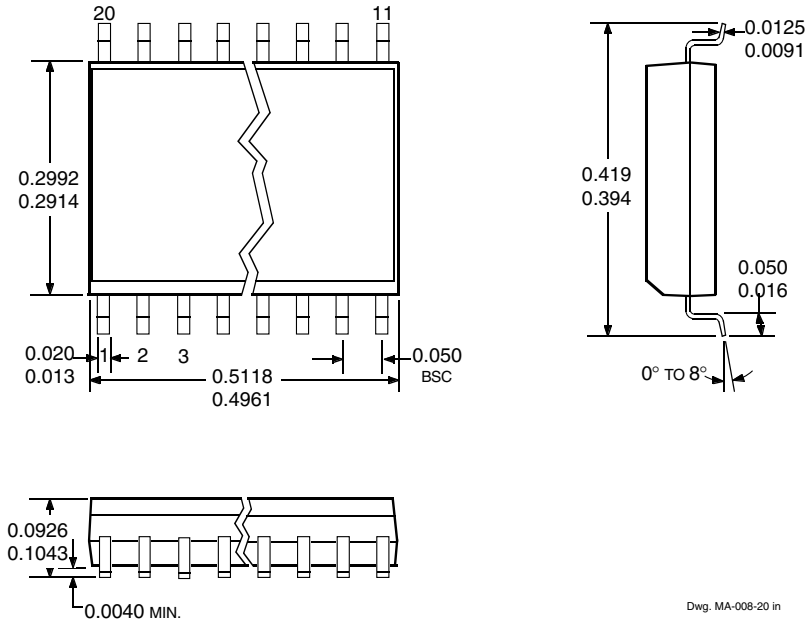

Dimensions in Millimeters
(controlling dimensions)

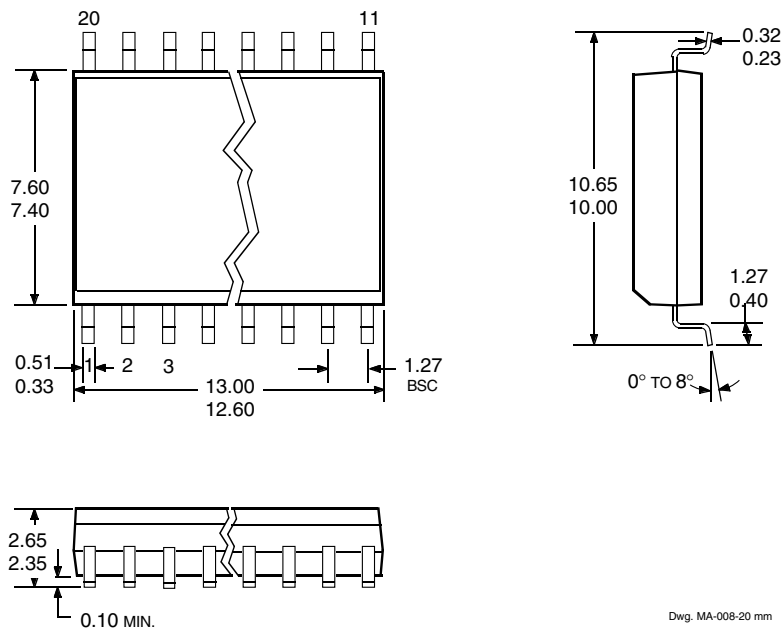

- NOTES: 1. Exact body and lead configuration at vendor's option within limits shown.
2. Lead spacing tolerance is non-cumulative.
3. Supplied in standard sticks/tubes of 37 devices or add "TR" to part number for tape and reel.

6118
VACUUM FLUORESCENT
DISPLAY DRIVER

The products described here are manufactured under one or more U.S. patents or U.S. patents pending.

Allegro MicroSystems, Inc. reserves the right to make, from time to time, such departures from the detail specifications as may be required to permit improvements in the performance, reliability, or manufacturability of its products. Before placing an order, the user is cautioned to verify that the information being relied upon is current.

Allegro products are not authorized for use as critical components in life-support devices or systems without express written approval.

The information included herein is believed to be accurate and reliable. However, Allegro MicroSystems, Inc. assumes no responsibility for its use; nor for any infringement of patents or other rights of third parties which may result from its use.

6118
VACUUM FLUORESCENT
DISPLAY DRIVER

***HIGH-VOLTAGE (≥ 60 V) PERIPHERAL POWER
AND DISPLAY DRIVERS***

IN ORDER OF 1) OUTPUT VOLTAGE, 2) OUTPUT CURRENT, 3) NUMBER OF DRIVERS

Output Ratings*			Features					Part Number †
V	mA	#	Serial Input	Latched Drivers	Diode Clamp	Saturated Outputs	Internal Protection	
60	-25	8	–	X	–	–	–	5815
	-25	10	X	X	Active Pull-Down	–	–	5810-F and 6809/10
	-25	12	X	X	Active Pull-Down	–	–	5811 and 6811
	-25	20	X	X	Active Pull-Down	–	–	5812-F and 6812
	-25	32	X	X	Active Pull-Down	–	–	5818-F and 6818
	300	4	–	–	X	X	X	2557
	600	4	–	–	–	X	X	2547
	600	4	–	–	X	X	X	2549
	700	4	–	–	X	X	X	2559
	700	4	–	–	X	X	X	2543
	4000	4	–	–	X	–	–	2944
80	-350	8	–	–	X	–	–	2983 and 2984
	350	8	X	X	–	–	–	5822
	350	8	X	X	X	–	–	5842
	-350	8	X	X	X	–	–	5890
	1500	4	–	–	–	–	–	2065 and 2069
	4000	4	–	–	X	–	–	2879
85	-25	8	–	–	–	–	–	6118
95	300	7	–	–	X	–	–	2023
	300	8	–	–	X	–	–	2823
	350	7	–	–	X	–	–	2024
	350	8	–	–	X	–	–	2824
135	250	7	–	–	X	–	–	7003

* Current is maximum test condition; voltage is absolute maximum allowable.

Negative current is defined as coming out of (sourcing) the output.

† Complete part number includes additional characters to indicate operating temperature range and package style.