

MAXIM

2.5Ω, Quad, SPST, CMOS Analog Switches

MAX4661/MAX4662/MAX4663

General Description

The MAX4661/MAX4662/MAX4663 quad analog switches feature low on-resistance of 2.5Ω max. On-resistance is matched between switches to 0.5Ω max and is flat (0.5Ω max) over the specified signal range. Each switch can handle Rail-to-Rail® analog signals. Off-leakage current is only 5nA max at T_A = +85°C. These analog switches are ideal in low-distortion applications and are the preferred solution over mechanical relays in automatic test equipment or applications where current switching is required. They have lower power requirements, use less board space, and are more reliable than mechanical relays.

The MAX4661 has four normally closed (NC) switches, and the MAX4662 has four normally open (NO) switches. The MAX4663 has two NC and two NO switches, and features guaranteed break-before-make switching.

These devices operate from a single +4.5V to +36V supply or from dual ±4.5V to ±20V supplies. A separate logic supply pin guarantees TTL/CMOS-logic compatibility when operating across the entire supply voltage range.

Applications

Reed Relay Replacement	Avionics
Test Equipment	ADC Systems
Communication Systems	Sample-and-Hold Circuits
PBX, PABX Systems	Data Acquisition Systems
Audio-Signal Routing	

Features

- ◆ Low On-Resistance (2.5Ω max)
- ◆ Guaranteed R_{ON} Match Between Channels (0.5Ω max)
- ◆ Guaranteed R_{ON} Flatness over Specified Signal Range (0.5Ω max)
- ◆ Rail-to-Rail Signal Handling
- ◆ Guaranteed Break-Before-Make (MAX4663)
- ◆ > 2kV ESD Protection per Method 3015.7
- ◆ +4.5V to +36V Single-Supply Operation
±4.5V to ±20V Dual-Supply Operation
- ◆ TTL/CMOS-Compatible Control Inputs

Ordering Information

PART	TEMP. RANGE	PIN-PACKAGE
MAX4661CAE	0°C to +70°C	16 SSOP
MAX4661CWE	0°C to +70°C	16 Wide SO
MAX4661CPE	0°C to +70°C	16 Plastic DIP
MAX4661EAE	-40°C to +85°C	16 SSOP
MAX4661EWE	-40°C to +85°C	16 Wide SO
MAX4661EPE	-40°C to +85°C	16 Plastic DIP

Ordering Information continued at end of data sheet.

Pin Configurations/Functional Diagrams/Truth Tables

TOP VIEW

SSOP/SO/DIP

MAX4661	
LOGIC	SWITCH
0	ON
1	OFF

SSOP/SO/DIP

MAX4662	
LOGIC	SWITCH
0	OFF
1	ON

SSOP/SO/DIP

MAX4663		
LOGIC	SWITCHES 1, 4	SWITCHES 2, 3
0	OFF	ON
1	ON	OFF

SWITCHES SHOWN FOR LOGIC "0" INPUT

Rail-to-Rail is a registered trademark of Nippon Motorola, Ltd.

2.5Ω, Quad, SPST, CMOS Analog Switches

ABSOLUTE MAXIMUM RATINGS

V+ to GND	-0.3V to +44V
V- to GND	+0.3V to -44V
V+ to V-	-0.3V to +44V
V _L to GND	(GND - 0.3V) to (V+ + 0.3V)
All Other Pins to GND (Note 1)	(V- - 0.3V) to (V+ + 0.3V)
Continuous Current (COM ₊ , NO ₊ , NC ₊)	±200mA
Peak Current (COM ₊ , NO ₊ , NC ₊) (pulsed at 1ms, 10% duty cycle)	±300mA

Continuous Power Dissipation (T _A = +70°C)	
SSOP (derate 7.1mW/°C above +70°C)	571mW
Wide SO (derate 9.52mW/°C above +70°C)	762mW
Plastic DIP (derate 10.53mW/°C above +70°C)	842mW
Operating Temperature Ranges	
MAX466_C_E	0°C to +70°C
MAX466_E_E	-40°C to +85°C
Storage Temperature Range	-65°C to +150°C
Lead Temperature (soldering, 10sec)	+300°C

Note 1: Signals on NC₊, NO₊, COM₊, or IN₊ exceeding V+ or V- will be clamped by internal diodes. Limit forward diode current to maximum current rating.

Stresses beyond those listed under "Absolute Maximum Ratings" may cause permanent damage to the device. These are stress ratings only, and functional operation of the device at these or any other conditions beyond those indicated in the operational sections of the specifications is not implied. Exposure to absolute maximum rating conditions for extended periods may affect device reliability.

ELECTRICAL CHARACTERISTICS—Dual Supplies

(V+ = +15V, V- = -15V, V_L = +5V, V_{IN_H} = +2.4V, V_{IN_L} = +0.8V, T_A = T_{MIN} to T_{MAX}, unless otherwise noted. Typical values are at T_A = +25°C.) (Note 2)

PARAMETER	SYMBOL	CONDITIONS	MIN	TYP	MAX	UNITS	
ANALOG SWITCH							
Input Voltage Range (Note 3)	V _{COM₊} , V _{NO₊} , V _{NC₊}		V-		V+	V	
COM ₊ to NO ₊ or NC ₊ On-Resistance	R _{ON}	I _{COM₊} = 10mA, V _{NO₊} or V _{NC₊} = ±10V	T _A = +25°C	1.7	2.5	Ω	
			T _A = T _{MIN} to T _{MAX}		2.7		
COM ₊ to NO ₊ or NC ₊ On-Resistance Match Between Channels (Notes 3, 4)	ΔR _{ON}	I _{COM₊} = 10mA, V _{NO₊} or V _{NC₊} = ±10V	T _A = +25°C	0.1	0.5	Ω	
			T _A = T _{MIN} to T _{MAX}		0.6		
COM ₊ to NO ₊ or NC ₊ On-Resistance Flatness (Notes 3, 5)	R _{FLAT(ON)}	I _{COM₊} = 10mA; V _{NO₊} or V _{NC₊} = -5V, 0, 5V	T _A = +25°C	0.1	0.5	Ω	
			T _A = T _{MIN} to T _{MAX}		0.6		
Off-Leakage Current (NO ₊ or NC ₊) (Note 6)	I _{NO₊} , I _{NC₊}	V _{COM₊} = ±10V, V _{NO₊} or V _{NC₊} = ∓10V	T _A = +25°C	-0.5	0.01	0.5	nA
			T _A = T _{MIN} to T _{MAX}	-5		5	
COM Off-Leakage Current (Note 6)	I _{COM₊(OFF)}	V _{COM₊} = ±10V, V _{NO₊} or V _{NC₊} = ∓10V	T _A = +25°C	-0.5	0.01	0.5	nA
			T _A = T _{MIN} to T _{MAX}	-5		5	
COM On-Leakage Current (Note 6)	I _{COM₊(ON)}	V _{COM₊} = ±10V, V _{NO₊} or V _{NC₊} = ±10V or floating	T _A = +25°C	-1	0.01	1	nA
			T _A = T _{MIN} to T _{MAX}	-20		20	
LOGIC INPUT							
Input Current with Input Voltage High	I _{IN_H}	IN ₊ = 2.4V, all others = 0.8V	-0.5	0.001	0.5	μA	
Input Current with Input Voltage Low	I _{IN_L}	IN ₊ = 0.8V, all others = 2.4V	-0.5	0.001	0.5	μA	
Logic Input Voltage High	V _{IN_H}		2.4			V	
Logic Input Voltage Low	V _{IN_L}				0.8	V	

2.5Ω, Quad, SPST, CMOS Analog Switches

MAX4661/MAX4662/MAX4663

ELECTRICAL CHARACTERISTICS—Dual Supplies (continued)

(V+ = +15V, V- = -15V, VL = +5V, VIN_H = +2.4V, VIN_L = +0.8V, TA = TMIN to TMAX, unless otherwise noted. Typical values are at TA = +25°C.) (Note 2)

PARAMETER	SYMBOL	CONDITIONS		MIN	TYP	MAX	UNITS
POWER SUPPLY							
Power-Supply Range				±4.5		±20.0	V
Positive Supply Current	I+	VIN = 0 or 5V	TA = +25°C	-0.5	0.001	0.5	μA
			TA = TMIN to TMAX	-5		5	
Negative Supply Current	I-	VIN = 0 or 5V	TA = +25°C	-0.5	0.001	0.5	μA
			TA = TMIN to TMAX	-5		5	
Logic Supply Current	IL	VIN = 0 or 5V	TA = +25°C	-0.5	0.001	0.5	μA
			TA = TMIN to TMAX	-5		5	
Ground Current	IGND	VIN = 0 or 5V	TA = +25°C	-0.5	0.001	0.5	μA
			TA = TMIN to TMAX	-5		5	
SWITCH DYNAMIC CHARACTERISTICS							
Turn-On Time	tON	VCOM_ = ±10V, Figure 2	TA = +25°C		130	275	ns
			TA = TMIN to TMAX			400	
Turn-Off Time	tOFF	VCOM_ = ±10V, Figure 2	TA = +25°C		100	175	ns
			TA = TMIN to TMAX			300	
Break-Before-Make Time (MAX4663 only)	tOPEN	VCOM_ = ±10V, Figure 3, TA = +25°C		5	30		ns
Charge Injection	Q	CL = 1.0nF, VGEN = 0, RGEN = 0, Figure 4			300		pC
Off-Isolation (Note 7)	VISO	RL = 50Ω, CL = 5pF, f = 1MHz, Figure 5			-56		dB
Crosstalk (Note 8)	VCT	RL = 50Ω, CL = 5pF, f = 1MHz, Figure 6			-59		dB
NC_ or NO_ Capacitance	COFF	f = 1MHz, Figure 7			55		pF
COM_ Off-Capacitance	CCOM	f = 1MHz, Figure 7			55		pF
On-Capacitance	CCOM	f = 1MHz, Figure 8			250		pF

2.5Ω, Quad, SPST, CMOS Analog Switches

ELECTRICAL CHARACTERISTICS—Single Supply

(V+ = +12V, V- = 0, VL = +5V, VIN_H = +2.4V, VIN_L = +0.8V, TA = TMIN to TMAX, unless otherwise noted. Typical values are at TA = +25°C.) (Note 2)

PARAMETER	SYMBOL	CONDITIONS	MIN	TYP	MAX	UNITS	
ANALOG SWITCH							
Input Voltage Range (Note 3)	VCOM_, VNO_, VNC_		GND		V+	V	
COM_ to NO_ or NC_ On-Resistance	RON	ICOM_ = 10mA, VNO_ or VNC_ = 10V	TA = +25°C TA = TMIN to TMAX	3	4 5	Ω	
COM_ to NO_ or NC_ On-Resistance Match Between Channels (Notes 3, 4)	ΔRON	ICOM_ = 10mA, VNO_ or VNC_ = 10V	TA = +25°C TA = TMIN to TMAX	0.03	0.4 0.5	Ω	
COM_ to NO_ or NC_ On-Resistance Flatness (Notes 3, 5)	RFLAT(ON)	ICOM_ = 10mA; VNO_ or VNC_ = 3V, 6V, 9V	TA = +25°C TA = TMIN to TMAX	0.1	0.7 0.8	Ω	
Off-Leakage Current (NO_ or NC_) (Notes 6, 9)	I _{NO_} I _{NC_}	VCOM_ = 1V, 10V; VNO_ or VNC_ = 10V, 1V	TA = +25°C TA = TMIN to TMAX	-0.5	0.01 5	nA	
COM Off-Leakage Current (Notes 6, 9)	ICOM(OFF)	VNO_ or VNC_ = 10V, 1V; VCOM_ = 1V, 10V	TA = +25°C TA = TMIN to TMAX	-0.5	0.01 5	nA	
COM On-Leakage Current (Notes 6, 9)	ICOM(ON)	VCOM_ = 1V, 10V; VNO_ or VNC_ = 1V, 10V, or floating	TA = +25°C TA = TMIN to TMAX	-1	0.01 20	nA	
LOGIC INPUT							
Input Current with Input Voltage High	IIN_H	IN_ = 2.4V, all others = 0.8V		-0.5	0.001	0.5	μA
Input Current with Input Voltage Low	IIN_L	IN_ = 0.8V, all others = 2.4V		-0.5	0.001	0.5	μA
Logic Input Voltage High	VIN_H			2.4			V
Logic Input Voltage Low	VIN_L					0.8	V
POWER SUPPLY							
Power-Supply Range				+4.5		+36.0	V
Positive Supply Current	I+	VIN = 0 or 5V	TA = +25°C TA = TMIN to TMAX	-0.5	0.001	0.5 5	μA
Logic Supply Current	IL	VIN = 0 or 5V	TA = +25°C TA = TMIN to TMAX	-0.5	0.001	0.5 5	μA
Ground Current	IGND	VIN = 0 or 5V	TA = +25°C TA = TMIN to TMAX	-0.5	0.001	0.5 5	μA

2.5Ω, Quad, SPST, CMOS Analog Switches

MAX4661/MAX4662/MAX4663

ELECTRICAL CHARACTERISTICS—Single Supply (continued)

(V+ = +12V, V- = 0, VL = +5V, VIN_H = +2.4V, VIN_L = +0.8V, TA = TMIN to TMAX, unless otherwise noted. Typical values are at TA = +25°C.) (Note 2)

PARAMETER	SYMBOL	CONDITIONS	MIN	TYP	MAX	UNITS
SWITCH DYNAMIC CHARACTERISTICS						
Turn-On Time (Note 3)	tON	VCOM_ = 10V, Figure 2	TA = +25°C	200	400	ns
			TA = TMIN to TMAX		500	
Turn-Off Time (Note 3)	tOFF	VCOM_ = 10V, Figure 2	TA = +25°C	100	250	ns
			TA = TMIN to TMAX		350	
Break-Before-Make Time (MAX4663 only) (Note 3)	tOPEN	VCOM_ = 10V, Figure 3, TA = +25°C	5	125		ns
Charge Injection	Q	CL = 1.0nF, VGEN = 0, RGEN = 0, Figure 4		20		pC
Crosstalk (Note 8)	VCT	RL = 50Ω, CL = 5pF, f = 1MHz, Figure 6		-60		dB
NC_ or NO_ Capacitance	COFF	f = 1MHz, Figure 7		85		pF
COM Off-Capacitance	CCOM	f = 1MHz, Figure 7		85		pF
On-Capacitance	CCOM	f = 1MHz, Figure 8		140		pF

Note 2: The algebraic convention, where the most negative value is a minimum and the most positive value a maximum, is used in this data sheet.

Note 3: Guaranteed by design.

Note 4: $\Delta R_{ON} = R_{ON(MAX)} - R_{ON(MIN)}$.

Note 5: Flatness is defined as the difference between the maximum and minimum value of on-resistance as measured over the specified analog signal range.

Note 6: Leakage parameters are 100% tested at maximum-rated hot temperature and guaranteed by correlation at +25°C.

Note 7: Off-isolation = $20 \log_{10} [V_{COM} / (V_{NC} \text{ or } V_{NO})]$, VCOM = output, VNC or VNO = input to off switch.

Note 8: Between any two switches.

Note 9: Leakage testing at single supply is guaranteed by testing with dual supplies.

2.5Ω, Quad, SPST, CMOS Analog Switches

Typical Operating Characteristics

($T_A = +25^\circ\text{C}$, unless otherwise noted.)

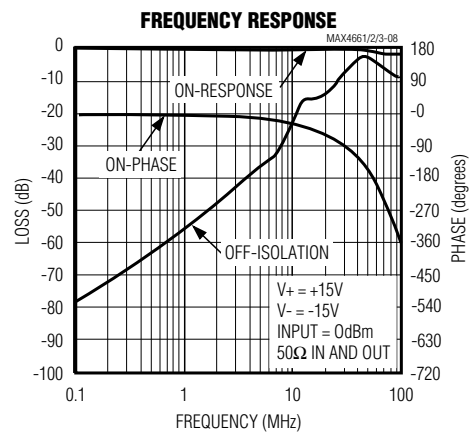
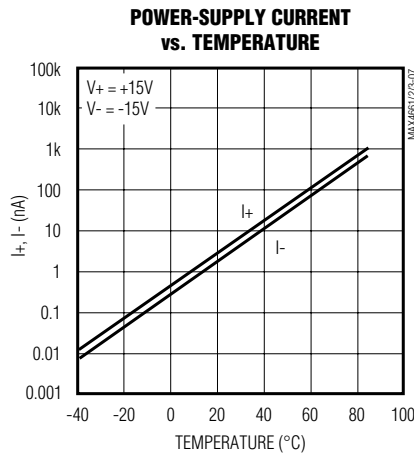
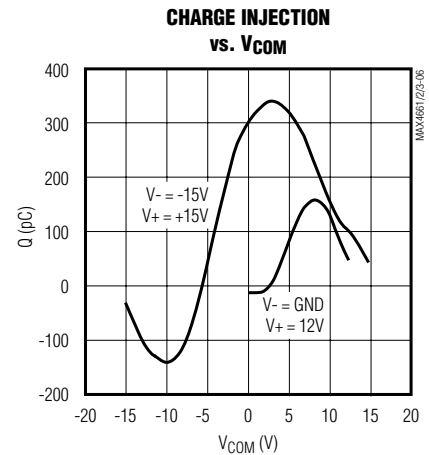
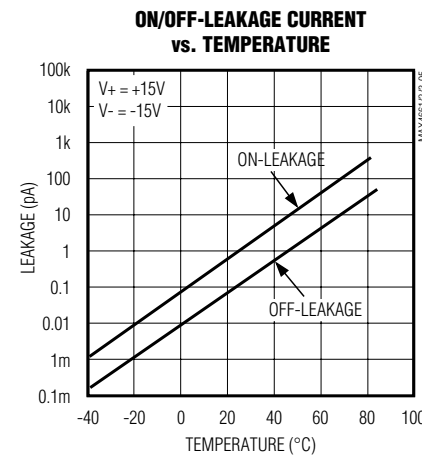
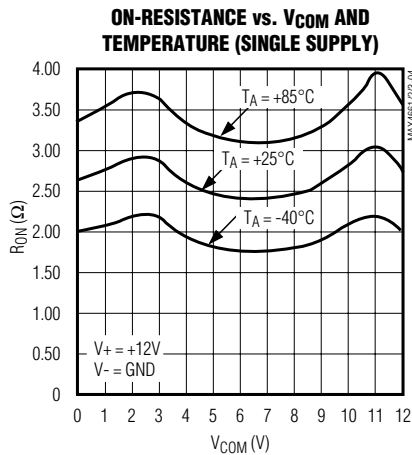
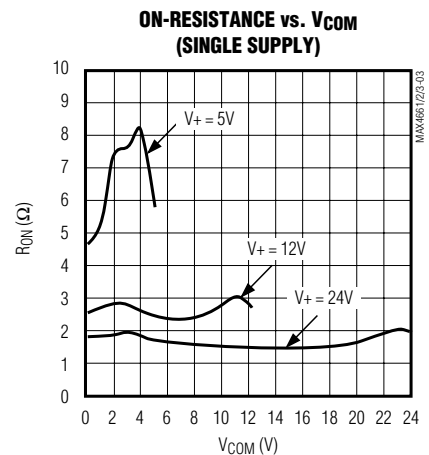
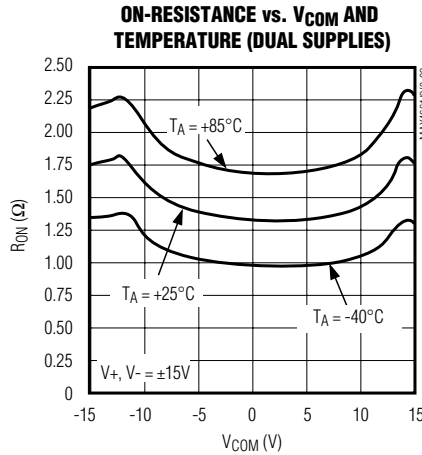
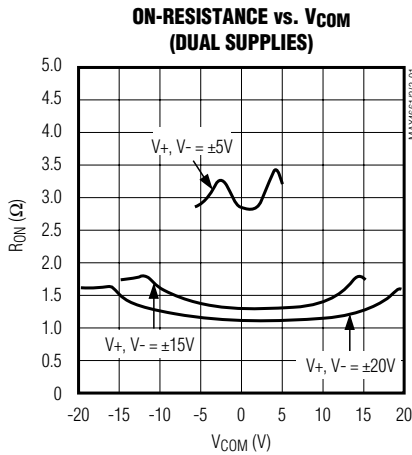

2.5Ω, Quad, SPST, CMOS Analog Switches

Pin Description

MAX4661/MAX4662/MAX4663

PIN			NAME	FUNCTION
MAX4661	MAX4662	MAX4663		
1, 16, 9, 8	1, 16, 9, 8	1, 16, 9, 8	IN1, IN2, IN3, IN4	Logic-Control Digital Inputs
2, 15, 10, 7	2, 15, 10, 7	2, 15, 10, 7	COM1, COM2, COM3, COM4	Analog Switch Common Terminals
3, 14, 11, 6	—	—	NC1, NC2, NC3, NC4	Analog Switch Normally Closed Terminals
—	3, 14, 11, 6	—	NO1, NO2, NO3, NO4	Analog Switch Normally Open Terminals
—	—	3, 6	NO1, NO4	Analog Switch Normally Open Terminals
—	—	14, 11	NC2, NC3	Analog Switch Normally Closed Terminals
4	4	4	V-	Negative Analog Supply-Voltage Input. Connect to GND for single-supply operation.
5	5	5	GND	Ground
12	12	12	V _L	Logic-Supply Input
13	13	13	V+	Positive Analog Supply Input

Applications Information

Overvoltage Protection

Proper power-supply sequencing is recommended for all CMOS devices. Do not exceed the absolute maximum ratings because stresses beyond the listed ratings can cause permanent damage to the devices. Always sequence V+ on first, then V-, followed by the logic inputs, NO, or COM. If power-supply sequencing is not possible, add two small-signal diodes (D1, D2) in series with the supply pins and a Schottky diode between V+ and V_L for overvoltage protection (Figure 1). Adding diodes reduces the analog signal range to one diode drop below V+ and one diode drop above V-, but does not affect the devices' low switch resistance and low leakage characteristics. Device operation is unchanged, and the difference between V+ and V- should not exceed 44V.

Off-Isolation at High Frequencies

In 50Ω systems, the high-frequency on-response of these parts extends from DC to above 100MHz with a typical loss of -2dB. When the switch is turned off, however, it behaves like a capacitor and off-isolation decreases with increasing frequency. (Above 300MHz, the switch actually passes more signal turned off than turned on.) This effect is more pronounced with higher source and load impedances.

Above 5MHz, circuit board layout becomes critical and it becomes difficult to characterize the response of the switch independent of the circuit. The graphs shown in the *Typical Operating Characteristics* were taken using a 50Ω source and load connected with BNC connectors to a circuit board deemed "average"; that is, designed with isolation in mind, but not using stripline or other special RF circuit techniques. For critical applications above 5MHz, use the MAX440, MAX441, and MAX442, which are fully characterized up to 160MHz.

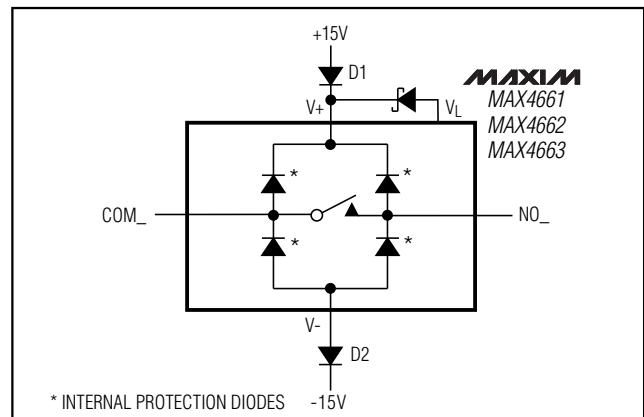

Figure 1. Overvoltage Protection Using External Blocking Diodes

2.5Ω, Quad, SPST, CMOS Analog Switches

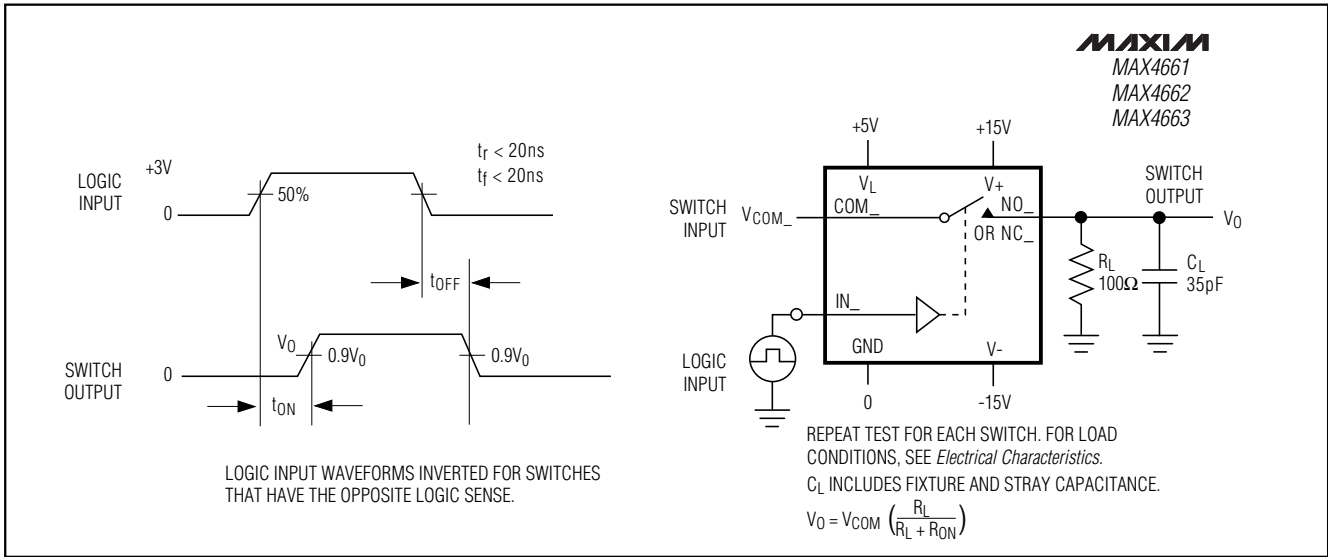

Figure 2. Switching-Time Test Circuit

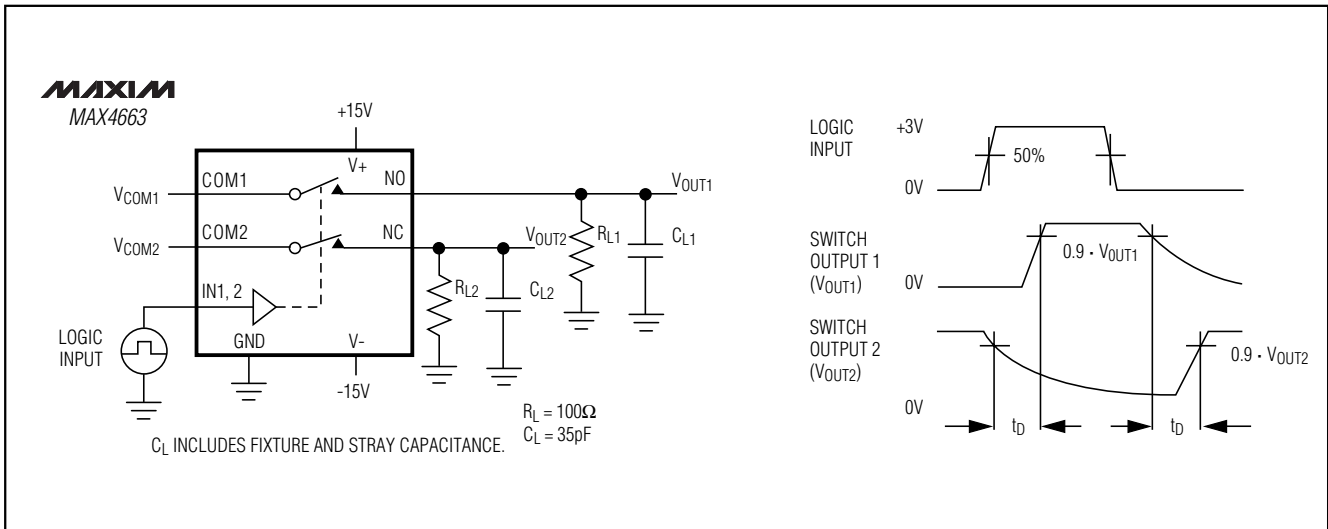

Figure 3. Break-Before-Make Interval (MAX4663 only)

2.5Ω, Quad, SPST, CMOS Analog Switches

MAX4661/MAX4662/MAX4663

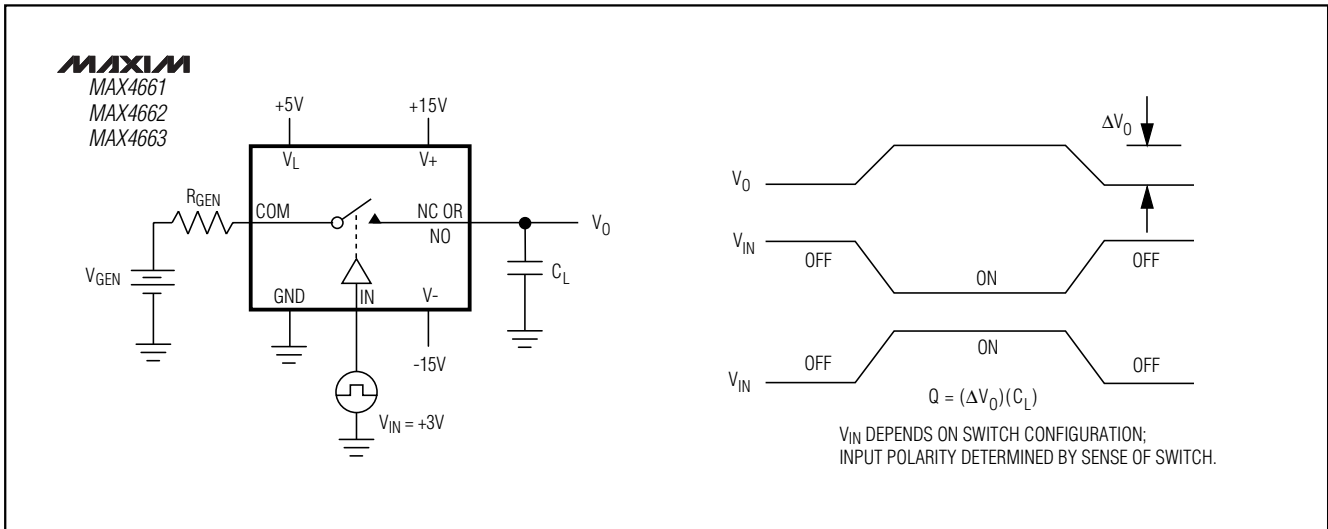

Figure 4. Charge-Injection Test Circuit

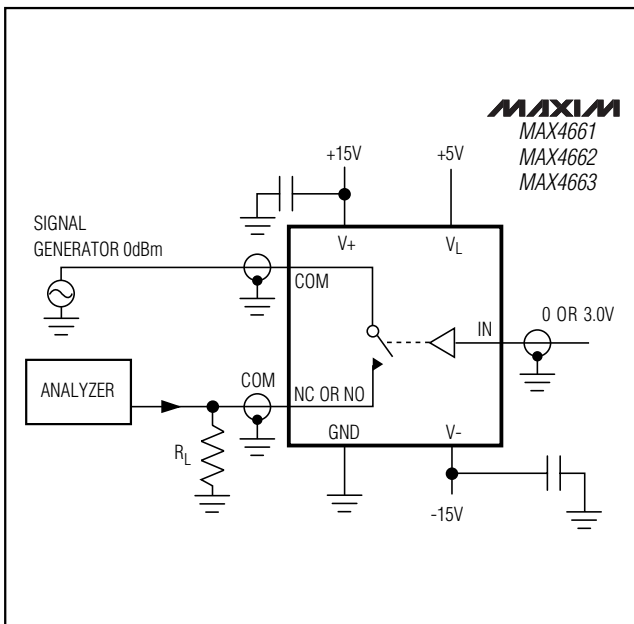

Figure 5. Off-Isolation Test Circuit

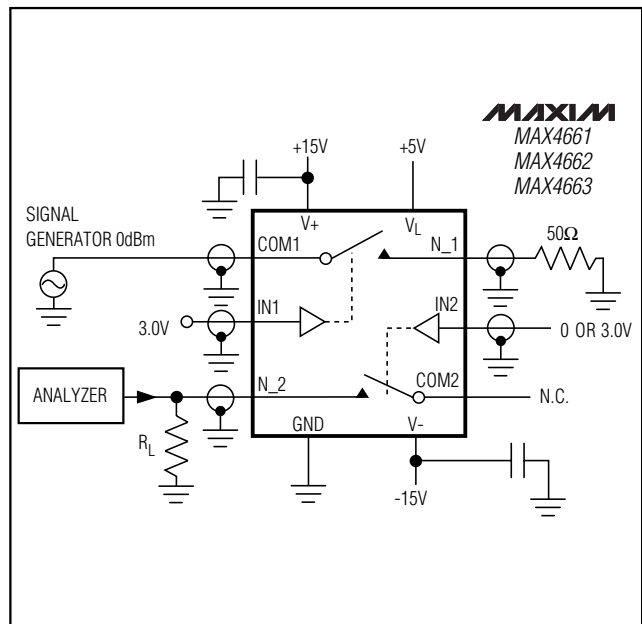

Figure 6. Crosstalk Test Circuit

2.5Ω, Quad, SPST, CMOS Analog Switches

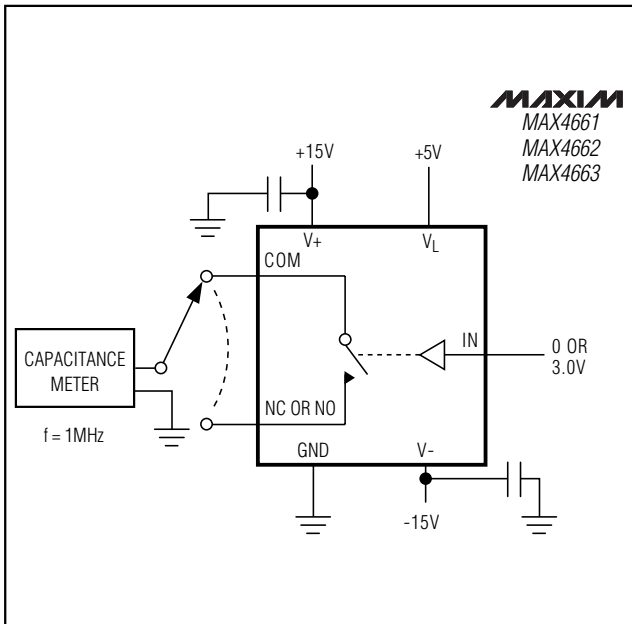

Figure 7. Switch Off-Capacitance Test Circuit

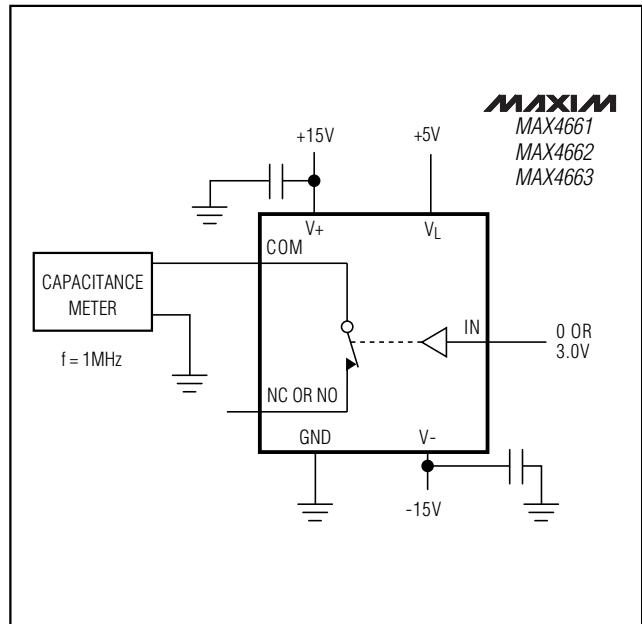

Figure 8. Switch On-Capacitance Test Circuit

Ordering Information (continued)

PART	TEMP. RANGE	PIN-PACKAGE
MAX4662 CAE	0°C to +70°C	16 SSOP
MAX4662CWE	0°C to +70°C	16 Wide SO
MAX4662CPE	0°C to +70°C	16 Plastic DIP
MAX4662EAE	-40°C to +85°C	16 SSOP
MAX4662EWE	-40°C to +85°C	16 Wide SO
MAX4662EPE	-40°C to +85°C	16 Plastic DIP
MAX4663 CAE	0°C to +70°C	16 SSOP
MAX4663CWE	0°C to +70°C	16 Wide SO
MAX4663CPE	0°C to +70°C	16 Plastic DIP
MAX4663EAE	-40°C to +85°C	16 SSOP
MAX4663EWE	-40°C to +85°C	16 Wide SO
MAX4663EPE	-40°C to +85°C	16 Plastic DIP

Chip Information

TRANSISTOR COUNT: 108

2.5Ω, Quad, SPST, CMOS Analog Switches

Package Information

MAX4661/MAX4662/MAX4663

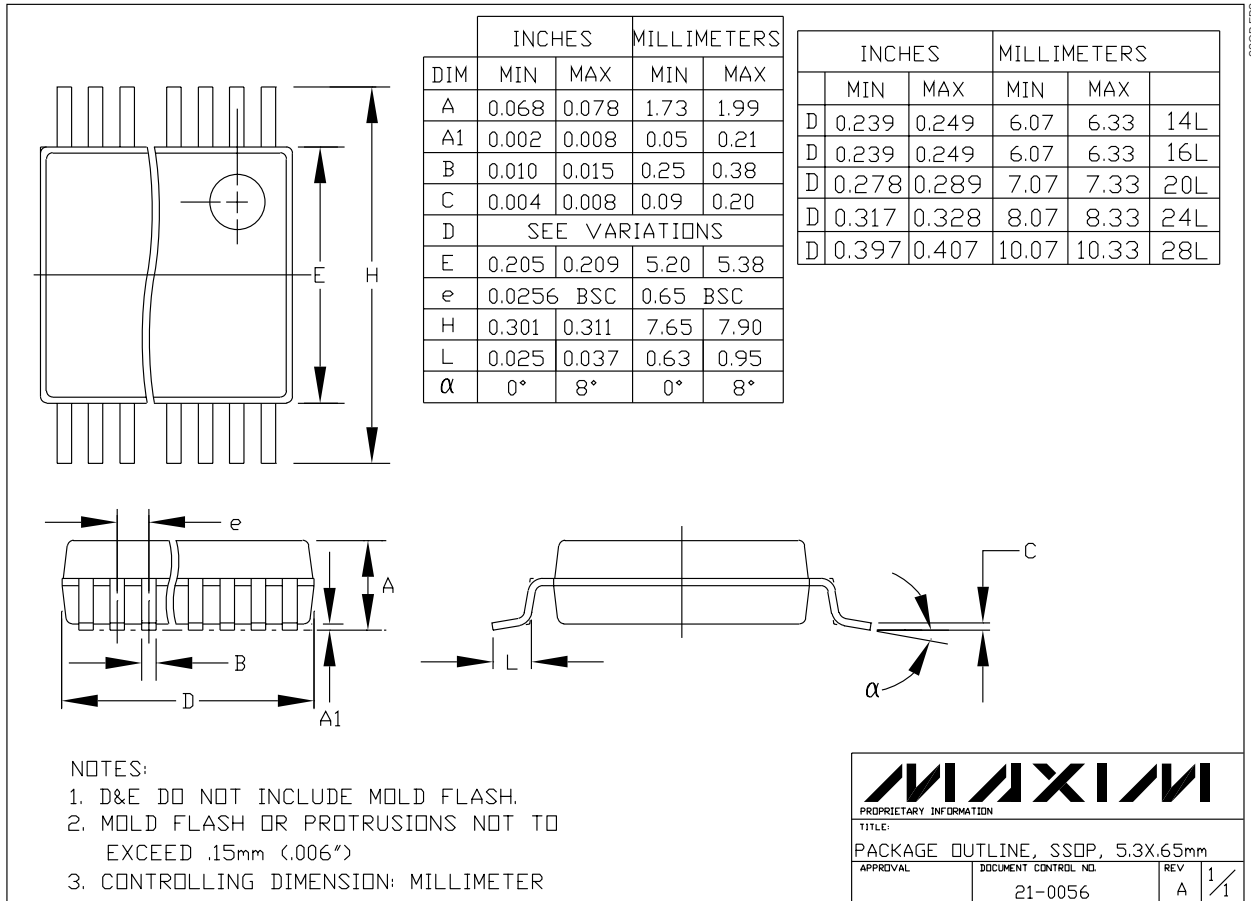

SSOP.EPS

2.5Ω, Quad, SPST, CMOS Analog Switches

Package Information (continued)

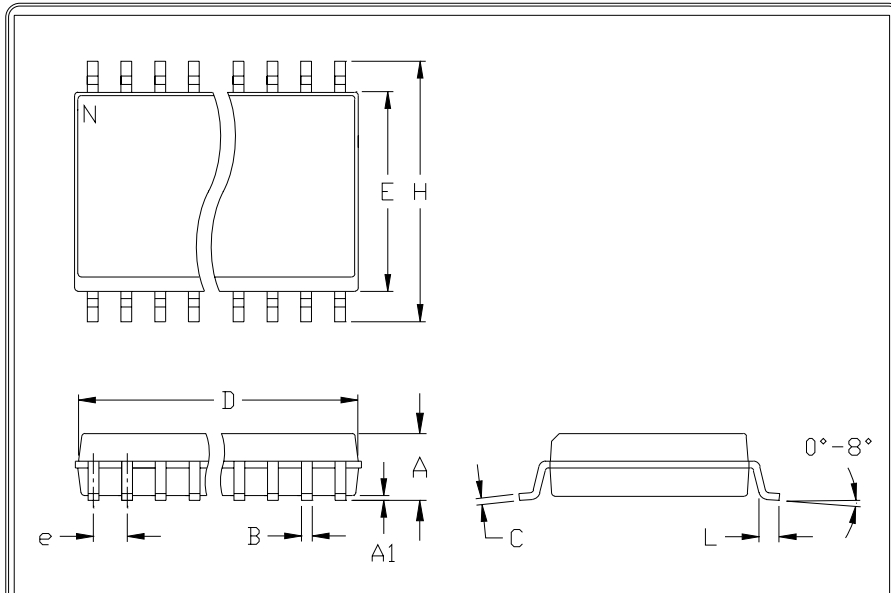

	INCHES		MILLIMETERS	
	MIN	MAX	MIN	MAX
A	0.093	0.104	2.35	2.65
A1	0.004	0.012	0.10	0.30
B	0.014	0.019	0.35	0.49
C	0.009	0.013	0.23	0.32
e	0.050		1.27	
E	0.291	0.299	7.40	7.60
H	0.394	0.419	10.00	10.65
h	0.010	0.030	0.25	0.75
L	0.016	0.050	0.40	1.27

	INCHES		MILLIMETERS		N	MS013
	MIN	MAX	MIN	MAX		
D	0.398	0.413	10.10	10.50	16	AA
D	0.447	0.463	11.35	11.75	18	AB
D	0.496	0.512	12.60	13.00	20	AC
D	0.598	0.614	15.20	15.60	24	AD
D	0.697	0.713	17.70	18.10	28	AE

- NOTES:
1. D&E DO NOT INCLUDE MOLD FLASH
 2. MOLD FLASH OR PROTRUSIONS NOT TO EXCEED .15mm (.006")
 3. LEADS TO BE COPLANAR WITHIN .102mm (.004")
 4. CONTROLLING DIMENSION: MILLIMETER
 5. MEETS JEDEC MS013-XX AS SHOWN IN ABOVE TABLE
 6. N = NUMBER OF PINS

 <small>120 SAN GABRIEL DR. SUNNYVALE, CA 94086 FAX 408-737-7704</small> <small>PROPRIETARY INFORMATION</small>	PACKAGE FAMILY OUTLINE: SOIC .300"	1/1	21-0042 A
	TITLE	DOCUMENT CONTROL NUMBER	REV

Maxim cannot assume responsibility for use of any circuitry other than circuitry entirely embodied in a Maxim product. No circuit patent licenses are implied. Maxim reserves the right to change the circuitry and specifications without notice at any time.