

IS62LV256

32K x 8 LOW VOLTAGE STATIC RAM

DECEMBER 2002

FEATURES

- Access time: 45, 70 ns
- Low active power: 70 mW
- Low standby power
 - 45 μ W CMOS standby
- Fully static operation: no clock or refresh required
- TTL compatible inputs and outputs
- Single 3.3V power supply

DESCRIPTION

The *ISSI* IS62LV256 is a very high-speed, low power, 32,768-word by 8-bit static RAM. It is fabricated using *ISSI*'s high-performance CMOS double-metal technology.

When \overline{CE} is HIGH (deselected), the device assumes a standby mode at which the power dissipation is reduced to 10 μ W (typical) with CMOS input levels.

Easy memory expansion is provided by using an active LOW Chip Enable (\overline{CE}) input and an active LOW Output Enable (\overline{OE}) input. The active LOW Write Enable (\overline{WE}) controls both writing and reading of the memory.

The IS62LV256 is pin compatible with other 32K x 8 SRAMs in 300-mil SOJ, 330-mil plastic SOP, and TSOP (Type I Normal and Reverse Bent) packages.

FUNCTIONAL BLOCK DIAGRAM

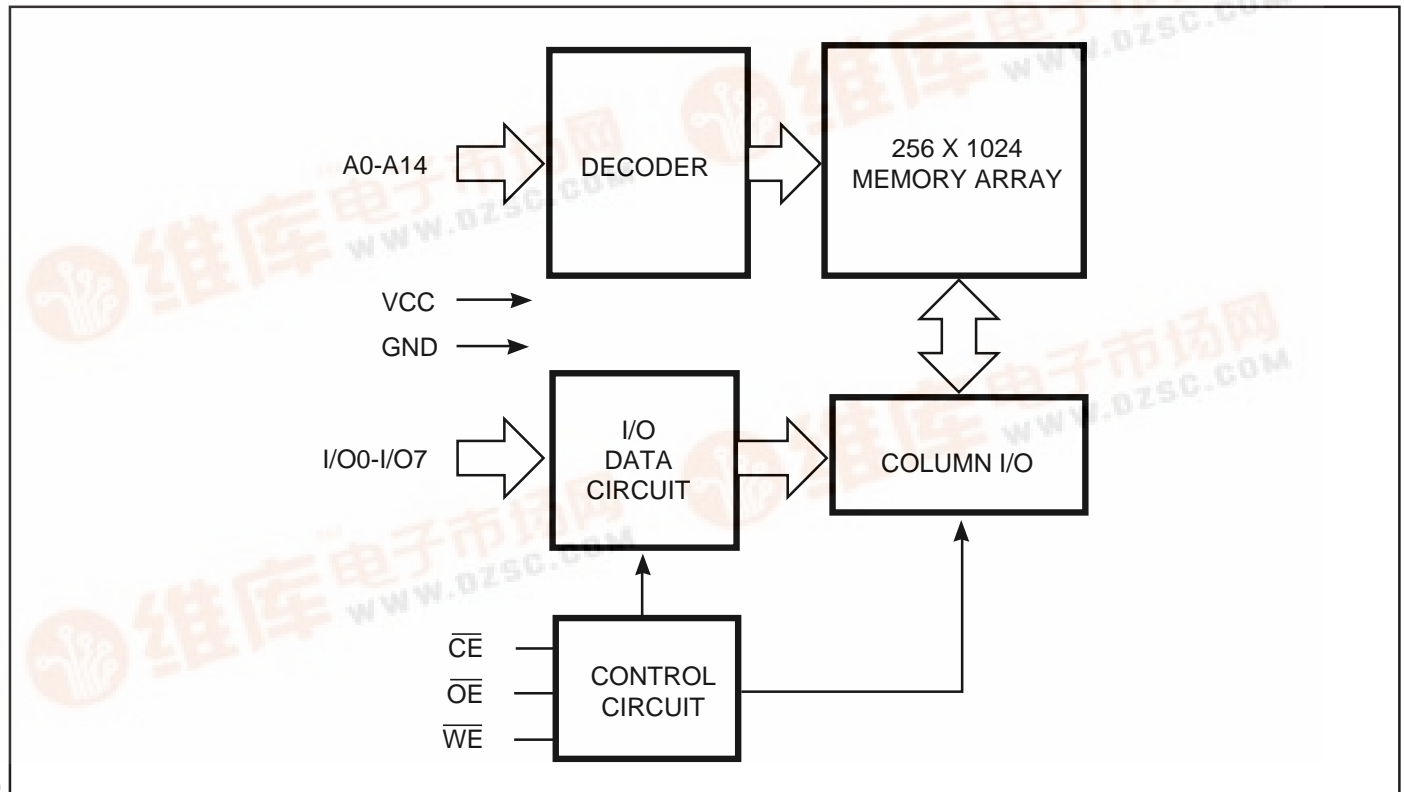

PIN CONFIGURATION
28-Pin SOJ and SOP

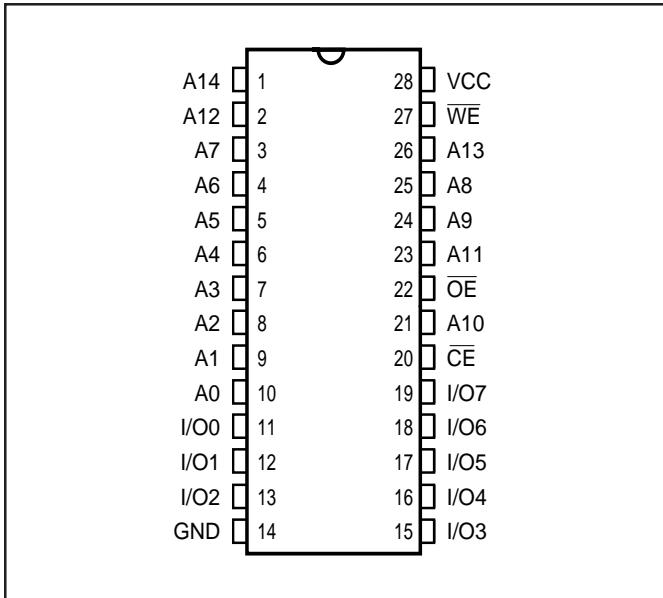

28-Pin TSOP (Type I) (Normal Bent)

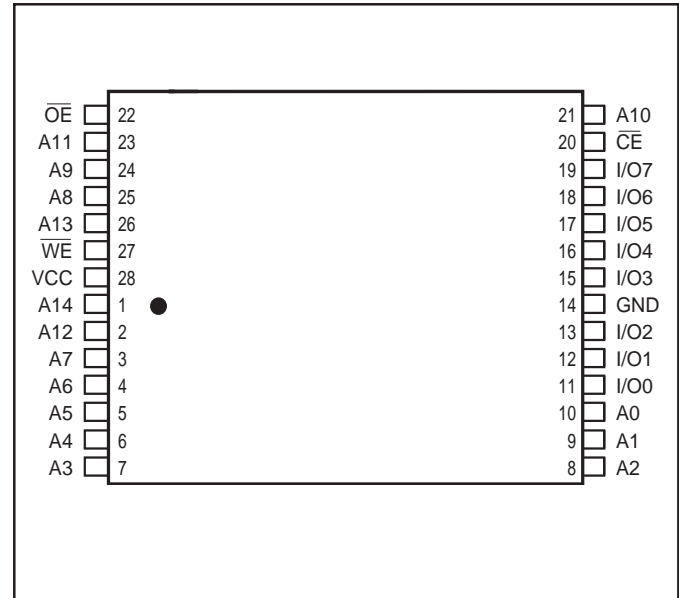

PIN DESCRIPTIONS

| | |
|-----------------|---------------------|
| A0-A14 | Address Inputs |
| \overline{CE} | Chip Enable Input |
| \overline{OE} | Output Enable Input |
| \overline{WE} | Write Enable Input |
| I/O0-I/O7 | Input/Output |
| Vcc | Power |
| GND | Ground |

28-Pin TSOP (Type I) (Reverse Bent)

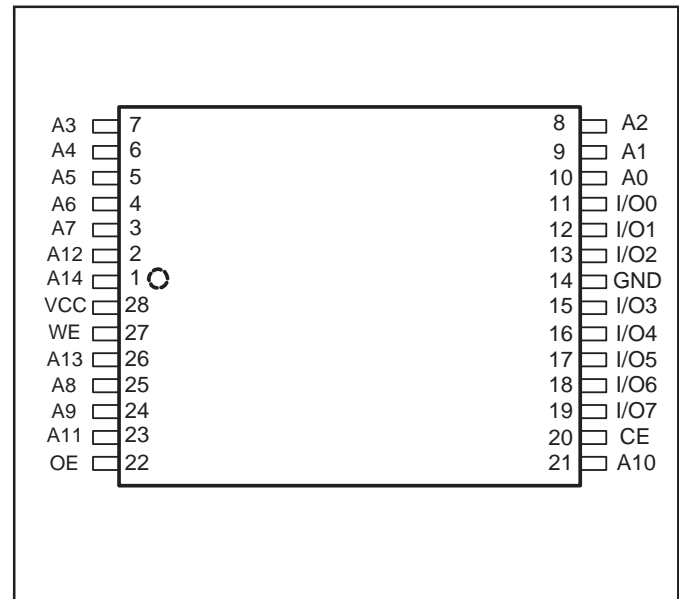

TRUTH TABLE

| Mode | \overline{WE} | \overline{CE} | \overline{OE} | I/O Operation | Vcc Current |
|------------------------------|-----------------|-----------------|-----------------|---------------|-------------|
| Not Selected (Power-down) | X | H | X | High-Z | Isb1, Isb2 |
| Output Disabled | H | L | H | High-Z | Icc1, Icc2 |
| Read | H | L | L | DOUT | Icc1, Icc2 |
| Write | L | L | X | DIN | Icc1, Icc2 |

ABSOLUTE MAXIMUM RATINGS⁽¹⁾

| Symbol | Parameter | Value | Unit |
|-------------------|--------------------------------------|--------------|------|
| V _{TERM} | Terminal Voltage with Respect to GND | −0.5 to +4.6 | V |
| T _{BIAS} | Temperature Under Bias | −55 to +125 | °C |
| T _{STG} | Storage Temperature | −65 to +150 | °C |
| P _T | Power Dissipation | 0.5 | W |
| I _{OUT} | DC Output Current (LOW) | 20 | mA |

Notes:

1. Stress greater than those listed under ABSOLUTE MAXIMUM RATINGS may cause permanent damage to the device. This is a stress rating only and functional operation of the device at these or any other conditions above those indicated in the operational sections of this specification is not implied. Exposure to absolute maximum rating conditions for extended periods may affect reliability.

OPERATING RANGE

| Range | Ambient Temperature | V _{CC} |
|------------|---------------------|-----------------|
| Commercial | 0°C to +70°C | 3.3V ± 5% |
| Industrial | −40°C to +85°C | 3.3V ± 5% |

DC ELECTRICAL CHARACTERISTICS (Over Operating Range)

| Symbol | Parameter | Test Conditions | Min. | Max. | Unit | |
|-----------------|----------------------------------|---|--------------|-----------------------|--------|----|
| V _{OH} | Output HIGH Voltage | V _{CC} = Min., I _{OH} = −1.0 mA | 2.4 | — | V | |
| V _{OL} | Output LOW Voltage | V _{CC} = Min., I _{OL} = 2.1 mA | — | 0.4 | V | |
| V _{IH} | Input HIGH Voltage | | 2.2 | V _{CC} + 0.3 | V | |
| V _{IL} | Input LOW Voltage ⁽¹⁾ | | −0.3 | 0.8 | V | |
| I _{LI} | Input Leakage | GND ≤ V _{IN} ≤ V _{CC} | Com. Ind. | −2 5 | 2 5 | μA |
| I _{LO} | Output Leakage | GND ≤ V _{OUT} ≤ V _{CC} , Outputs Disabled | Com. Ind. | −2 −5 | 2 5 | μA |

Notes:

1. V_{IL} = −3.0V for pulse width less than 10 ns.
2. Not more than one output should be shorted at one time. Duration of the short circuit should not exceed 30 seconds.

POWER SUPPLY CHARACTERISTICS⁽¹⁾ (Over Operating Range)

| Symbol | Parameter | Test Conditions | | -45 ns | | -70 ns | | Unit |
|------------------|--|---|------|--------|------|--------|------|------|
| | | | | Min. | Max. | Min. | Max. | |
| I _{CC1} | V _{CC} Operating Supply Current | V _{CC} = Max., $\overline{CE} = V_{IL}$ I _{OUT} = 0 mA, f = 0 | Com. | — | 20 | — | 20 | mA |
| | | | Ind. | — | 30 | — | 30 | |
| I _{CC2} | V _{CC} Dynamic Operating Supply Current | V _{CC} = Max., $\overline{CE} = V_{IL}$ I _{OUT} = 0 mA, f = f _{MAX} | Com. | — | 35 | — | 30 | mA |
| | | | Ind. | — | 45 | — | 40 | |
| I _{SB1} | TTL Standby Current (TTL Inputs) | V _{CC} = Max., V _{IN} = V _{IH} or V _{IL} $\overline{CE} \geq V_{IH}$, f = 0 | Com. | — | 2 | — | 2 | mA |
| | | | Ind. | — | 5 | — | 5 | |
| I _{SB2} | CMOS Standby Current (CMOS Inputs) | V _{CC} = Max., $\overline{CE} \geq V_{CC} - 0.2V$, V _{IN} $\geq V_{CC} - 0.2V$, or V _{IN} $\leq 0.2V$, f = 0 | Com. | — | 90 | — | 90 | μA |
| | | | Ind. | — | 200 | — | 200 | |

Notes:

- At f = f_{MAX}, address and data inputs are cycling at the maximum frequency, f = 0 means no input lines change.

CAPACITANCE^(1,2)

| Symbol | Parameter | Conditions | Max. | Unit |
|------------------|--------------------|-----------------------|------|------|
| C _{IN} | Input Capacitance | V _{IN} = 0V | 6 | pF |
| C _{OUT} | Output Capacitance | V _{OUT} = 0V | 5 | pF |

Notes:

- Tested initially and after any design or process changes that may affect these parameters.
- Test conditions: T_A = 25°C, f = 1 MHz, V_{CC} = 3.3V.

AC TEST CONDITIONS

| Parameter | Unit |
|--|-----------------------|
| Input Pulse Level | 0V to 3.0V |
| Input Rise and Fall Times | 5 ns |
| Input and Output Timing and Reference Levels | 1.5V |
| Output Load | See Figures 1a and 1b |

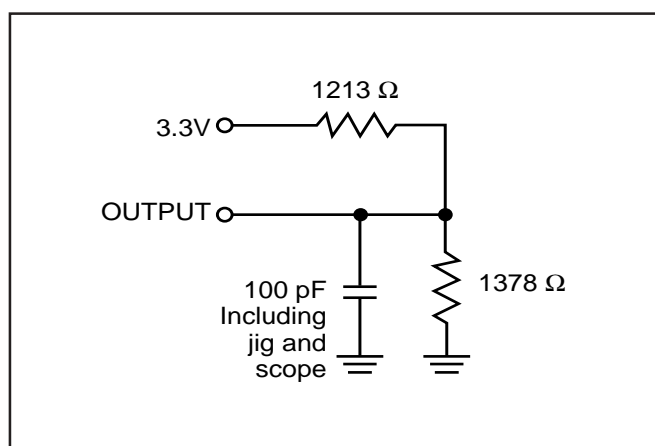

Figures 1a

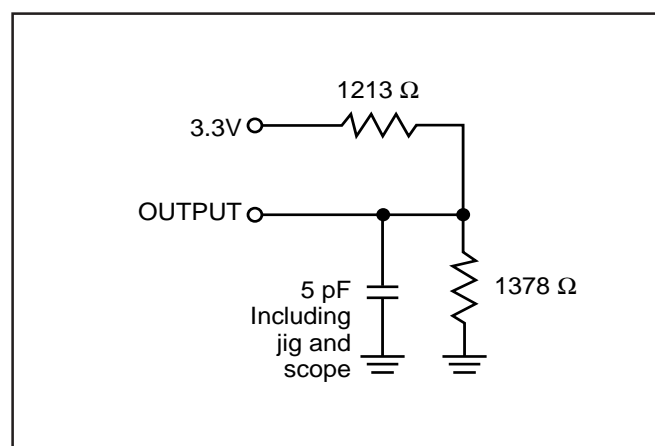

Figures 1b

READ CYCLE SWITCHING CHARACTERISTICS⁽¹⁾ (Over Operating Range)

| Symbol | Parameter | -45 ns | | -70 ns | | Unit |
|------------------|----------------------------------|--------|------|--------|------|------|
| | | Min. | Max. | Min. | Max. | |
| t_{RC} | Read Cycle Time | 45 | — | 70 | — | ns |
| t_{AA} | Address Access Time | — | 45 | — | 70 | ns |
| t_{OHA} | Output Hold Time | 2 | — | 2 | — | ns |
| t_{ACE} | \overline{CE} Access Time | — | 45 | — | 70 | ns |
| t_{DOE} | \overline{OE} Access Time | — | 25 | — | 35 | ns |
| $t_{LZOE}^{(2)}$ | \overline{OE} to Low-Z Output | 0 | — | 0 | — | ns |
| $t_{HZOE}^{(2)}$ | \overline{OE} to High-Z Output | 0 | 20 | 0 | 25 | ns |
| $t_{LZCE}^{(2)}$ | \overline{CE} to Low-Z Output | 3 | — | 3 | — | ns |
| $t_{HZCE}^{(2)}$ | \overline{CE} to High-Z Output | 0 | 20 | 0 | 25 | ns |
| $t_{PU}^{(3)}$ | \overline{CE} to Power-Up | 0 | — | 0 | — | ns |
| $t_{PD}^{(3)}$ | \overline{CE} to Power-Down | — | 30 | — | 50 | ns |

Notes:

- Test conditions assume signal transition times of 5 ns or less, timing reference levels of 1.5V, input pulse levels of 0 to 3.0V and output loading specified in Figure 1a.
- Tested with the load in Figure 1b. Transition is measured ± 500 mV from steady-state voltage. Not 100% tested.
- Not 100% tested.

AC WAVEFORMS

READ CYCLE NO. 1^(1,2)

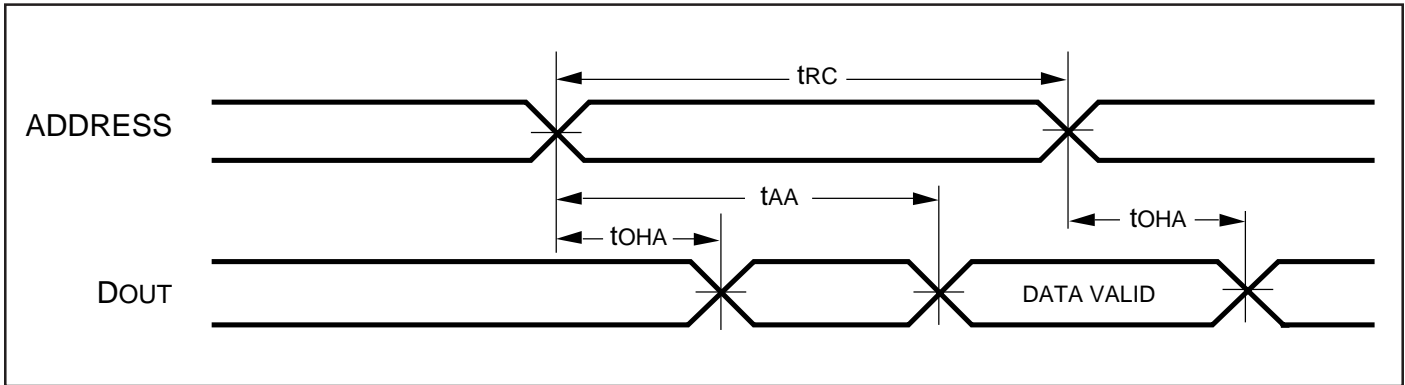

READ CYCLE NO. 2^(1,3)

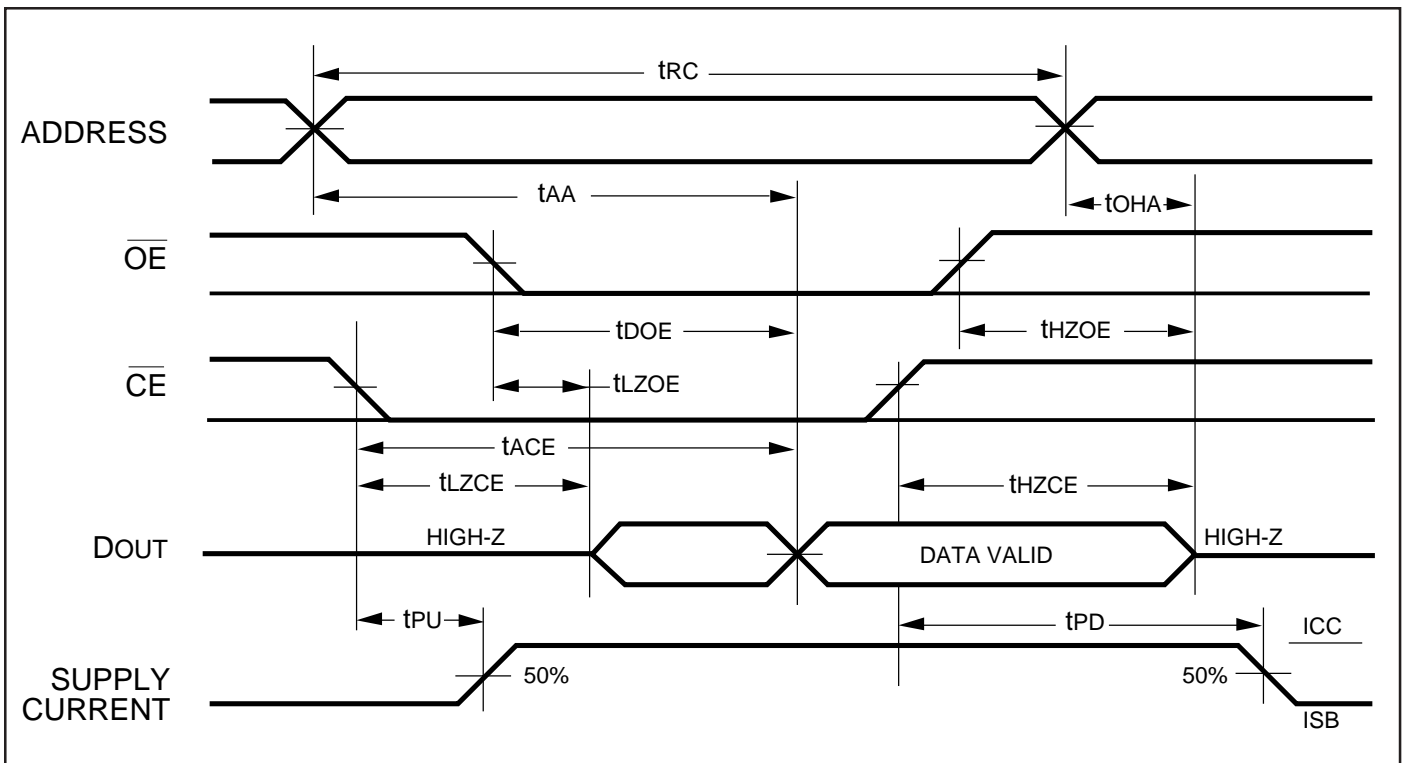

Notes:

1. \overline{WE} is HIGH for a Read Cycle.
2. The device is continuously selected. \overline{OE} , \overline{CE} = V_{IL} .
3. Address is valid prior to or coincident with \overline{CE} LOW transitions.

WRITE CYCLE SWITCHING CHARACTERISTICS^(1,2,3) (Over Operating Range)

| Symbol | Parameter | -45 ns | | -70 ns | | Unit |
|--------------------------------|-------------------------------------|--------|------|--------|------|------|
| | | Min. | Max. | Min. | Max. | |
| t _{WC} | Write Cycle Time | 45 | — | 70 | — | ns |
| t _{SCE} | $\overline{\text{CE}}$ to Write End | 35 | — | 60 | — | ns |
| t _{AW} | Address Setup Time to Write End | 25 | — | 60 | — | ns |
| t _{HA} | Address Hold from Write End | 0 | — | 0 | — | ns |
| t _{SA} | Address Setup Time | 0 | — | 0 | — | ns |
| t _{PWE⁽⁴⁾} | $\overline{\text{WE}}$ Pulse Width | 25 | — | 55 | — | ns |
| t _{SD} | Data Setup to Write End | 20 | — | 30 | — | ns |
| t _{HD} | Data Hold from Write End | 0 | — | 0 | — | ns |

Notes:

1. Test conditions assume signal transition times of 5 ns or less, timing reference levels of 1.5V, input pulse levels of 0 to 3.0V and output loading specified in Figure 1a.
2. Tested with the load in Figure 1b. Transition is measured ± 500 mV from steady-state voltage. Not 100% tested.
3. The internal write time is defined by the overlap of $\overline{\text{CE}}$ LOW and $\overline{\text{WE}}$ LOW. All signals must be in valid states to initiate a Write, but any one can go inactive to terminate the Write. The Data Input Setup and Hold timing are referenced to the rising or falling edge of the signal that terminates the Write.
4. Tested with $\overline{\text{OE}}$ HIGH.

AC WAVEFORMS

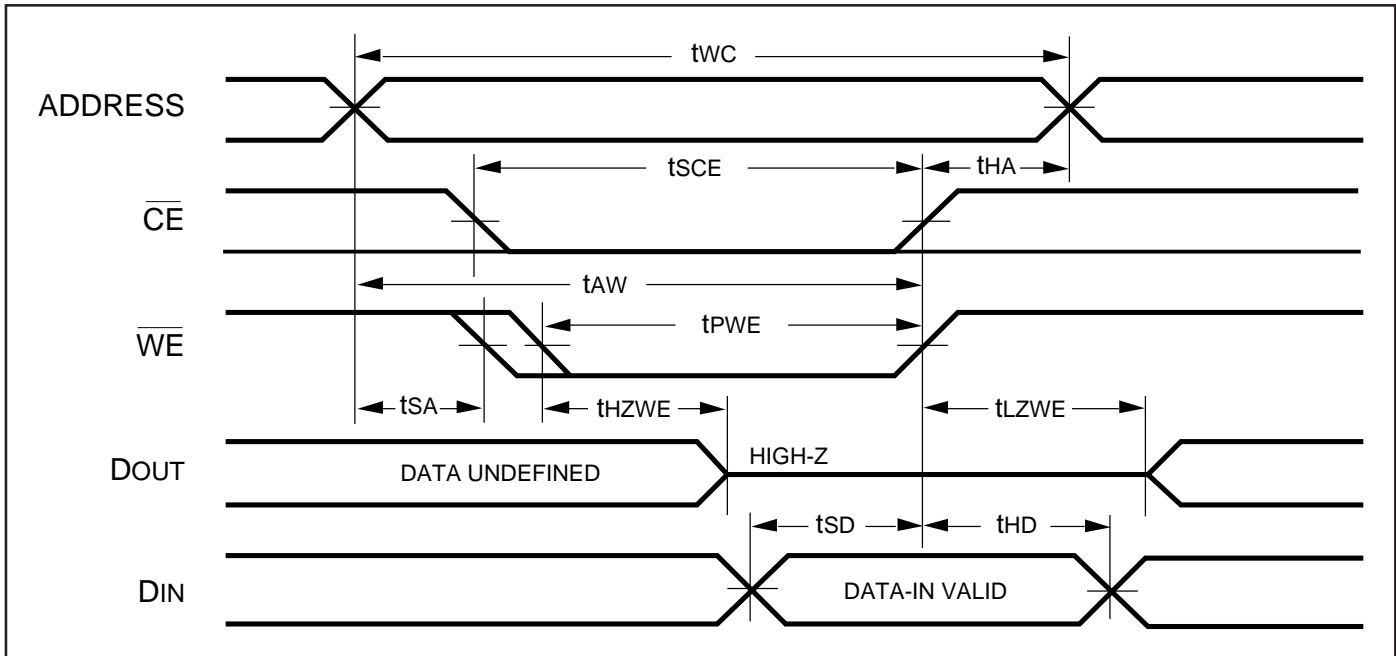
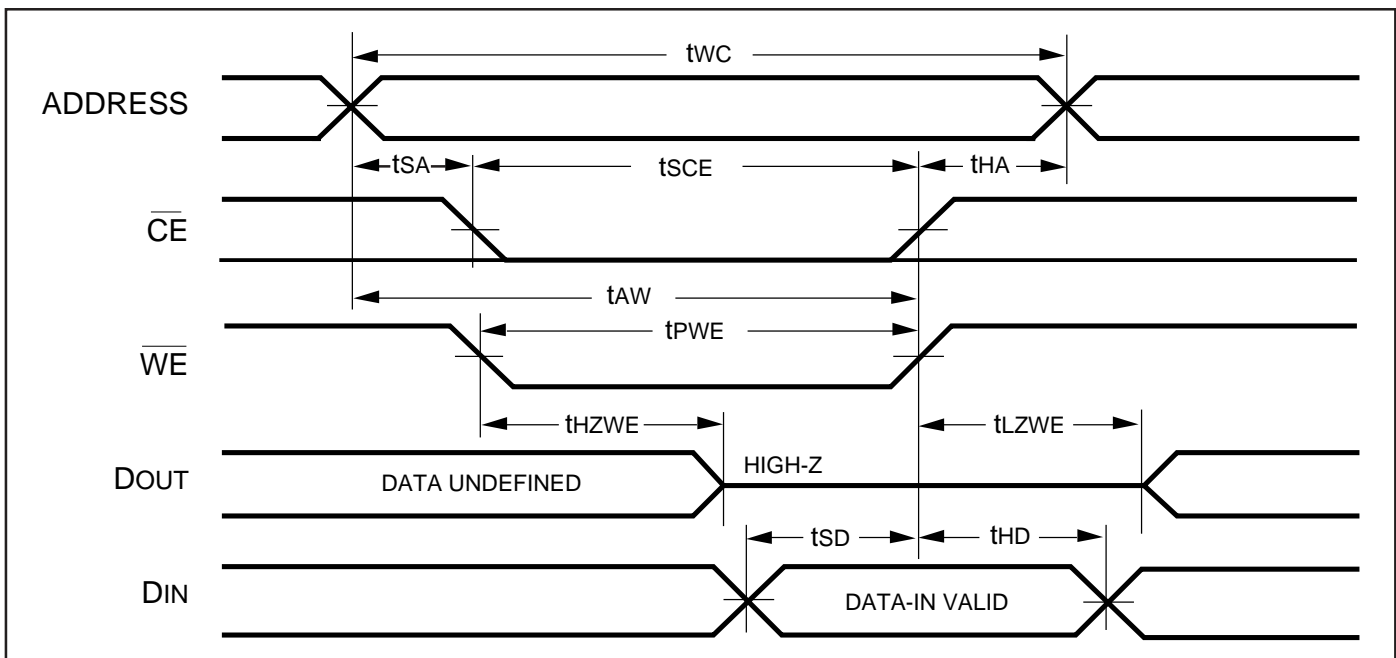
WRITE CYCLE NO. 1 ($\overline{\text{WE}}$ Controlled)^(1,2)WRITE CYCLE NO. 2 ($\overline{\text{CE}}$ Controlled)^(1,2)**Notes:**

1. The internal write time is defined by the overlap of $\overline{\text{CE}}$ LOW and $\overline{\text{WE}}$ LOW. All signals must be in valid states to initiate a Write, but any one can go inactive to terminate the Write. The Data Input Setup and Hold timing are referenced to the rising or falling edge of the signal that terminates the Write.
2. I/O will assume the High-Z state if $\overline{\text{OE}} \cdot V_{\text{IH}}$.

IS62LV256

ORDERING INFORMATION

Commercial Range: 0°C to +70°C

| Speed (ns) | Order Part No. | Package |
|------------|----------------|----------------------------|
| 45 | IS62LV256-45J | 300-MIL PLASTIC SOJ |
| 45 | IS62LV256-45U | 330-MIL SOP |
| 45 | IS62LV256-45T | TSOP (TYPE I NORMAL BENT) |
| 70 | IS62LV256-70U | 330-MIL SOP |
| 70 | IS62LV256-70T | TSOP (TYPE I NORMAL BENT) |
| 70 | IS62LV256-70RT | TSOP (TYPE I REVERSE BENT) |

Industrial Range: -40°C to +85°C

| Speed (ns) | Order Part No. | Package |
|------------|-----------------|----------------------------|
| 45 | IS62LV256-45JI | 300-MIL PLASTIC SOJ |
| 45 | IS62LV256-45UI | 330-mil SOP |
| 45 | IS62LV256-45TI | TSOP (TYPE I NORMAL BENT) |
| 70 | IS62LV256-70UI | 330-mil SOP |
| 70 | IS62LV256-70TI | TSOP (TYPE I NORMAL BENT) |
| 70 | IS62LV256-70RTI | TSOP (TYPE I REVERSE BENT) |