



New Product

Si6911DQ
Vishay Siliconix

Dual P-Channel 12-V (D-S) MOSFET

PRODUCT SUMMARY		
V_{DS} (V)	$r_{DS(on)}$ (Ω)	I_D (A)
-12	0.026 @ $V_{GS} = -4.5$ V	-5.1
	0.035 @ $V_{GS} = -2.5$ V	-4.5
	0.046 @ $V_{GS} = -1.8$ V	-3.9

FEATURES

- TrenchFET® Power MOSFETS

APPLICATIONS

- Load Switch
- Battery Switch

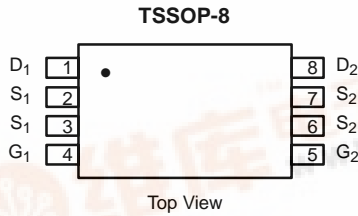

Ordering Information: Si6911DQ T-1

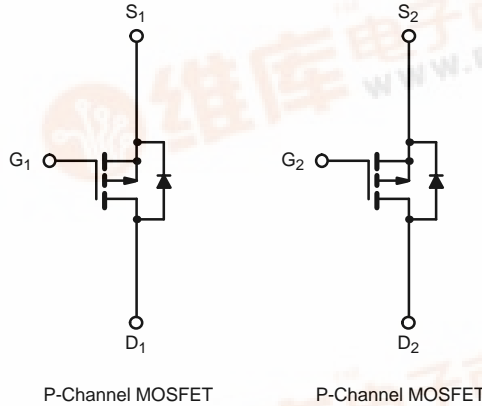

ABSOLUTE MAXIMUM RATINGS ($T_A = 25^\circ\text{C}$ UNLESS OTHERWISE NOTED)					
Parameter	Symbol	10 secs	Steady State	Unit	
Drain-Source Voltage	V_{DS}	-12		V	
Gate-Source Voltage	V_{GS}	± 8			
Continuous Drain Current ($T_J = 150^\circ\text{C}$) ^a	I_D	$T_A = 25^\circ\text{C}$	-5.1	-4.3	A
		$T_A = 70^\circ\text{C}$	-4.1	-3.5	
Pulsed Drain Current (10 μs Pulse Width)	I_{DM}	-30			
Continuous Source Current (Diode Conduction) ^a	I_S	-1.0	-0.7		
Maximum Power Dissipation ^a	P_D	$T_A = 25^\circ\text{C}$	1.14	0.83	W
		$T_A = 70^\circ\text{C}$	0.73	0.53	
Operating Junction and Storage Temperature Range	T_J, T_{stg}	-55 to 150		$^\circ\text{C}$	

THERMAL RESISTANCE RATINGS					
Parameter	Symbol	Typical	Maximum	Unit	
Maximum Junction-to-Ambient ^a	R_{thJA}	86	110	$t \leq 10$ sec	$^\circ\text{C/W}$
				Steady State	
Maximum Junction-to-Foot (Drain)	R_{thJF}	59	75	Steady State	

Notes:
a. Surface Mounted on 1" x 1" FR4 Board.



SPECIFICATIONS (T_J = 25 °C UNLESS OTHERWISE NOTED)						
Parameter	Symbol	Test Condition	Min	Typ	Max	Unit
Static						
Gate Threshold Voltage	V _{GS(th)}	V _{DS} = V _{GS} , I _D = -300 μA	-0.4		-0.9	V
Gate-Body Leakage	I _{GSS}	V _{DS} = 0 V, V _{GS} = ±8 V			±100	nA
Zero Gate Voltage Drain Current	I _{DSS}	V _{DS} = -9.6 V, V _{GS} = 0 V			-1	μA
		V _{DS} = -9.6 V, V _{GS} = 0 V, T _J = 70 °C			-25	
On-State Drain Current ^a	I _{D(on)}	V _{DS} = -5 V, V _{GS} = -4.5 V	-20			A
Drain-Source On-State Resistance ^a	r _{DS(on)}	V _{GS} = -4.5 V, I _D = -5.1 A		0.021	0.026	Ω
		V _{GS} = -2.5 V, I _D = -4.5 A		0.028	0.035	Ω
		V _{GS} = -1.8 V, I _D = -3.9 A		0.037	0.046	Ω
Forward Transconductance ^a	g _{fs}	V _{DS} = -5 V, I _D = -5.1 A		20		S
Diode Forward Voltage ^a	V _{SD}	I _S = -1.0 A, V _{GS} = 0 V		-0.65	-1.1	V
Dynamic^b						
Total Gate Charge	Q _g	V _{DS} = -6 V, V _{GS} = -4.5 V, I _D = -5.1 A		16	24	nC
Gate-Source Charge	Q _{gs}			1.9		
Gate-Drain Charge	Q _{gd}			3.9		
Turn-On Delay Time	t _{d(on)}	V _{DD} = -6 V, R _L = 6 Ω I _D ≅ -1 A, V _{GEN} = -4.5 V, R _G = 6 Ω		35	55	ns
Rise Time	t _r			62	100	
Turn-Off Delay Time	t _{d(off)}			120	180	
Fall Time	t _f			70	110	
Source-Drain Reverse Recovery Time	t _{rr}	I _F = -1.0 A, di/dt = 100 A/μs		65	100	

Notes

- a. Pulse test; pulse width ≤ 300 μs, duty cycle ≤ 2%.
- b. Guaranteed by design, not subject to production testing.

TYPICAL CHARACTERISTICS (25 °C UNLESS NOTED)

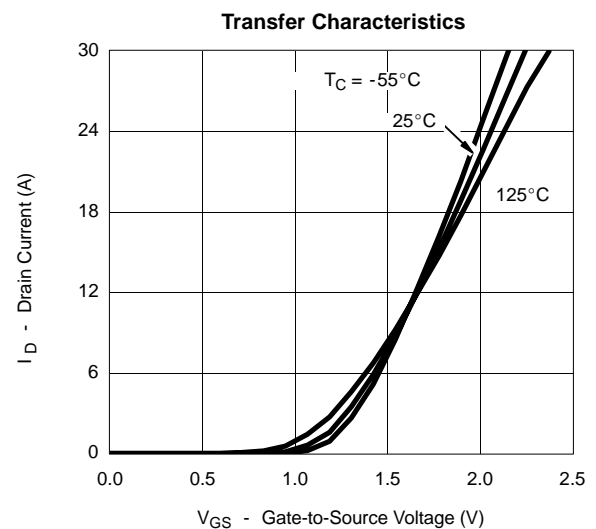
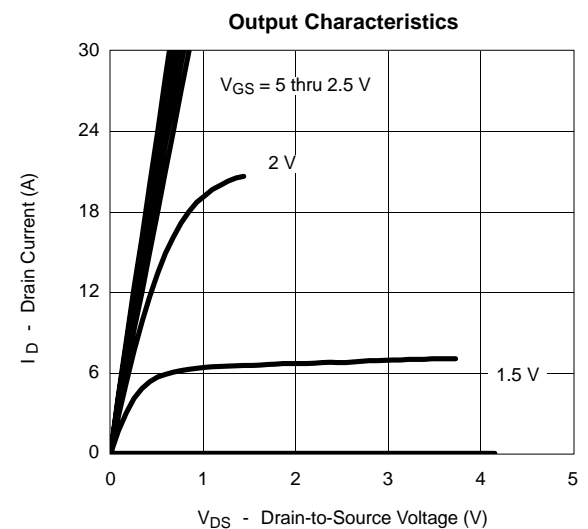



TYPICAL CHARACTERISTICS (25°C UNLESS NOTED)

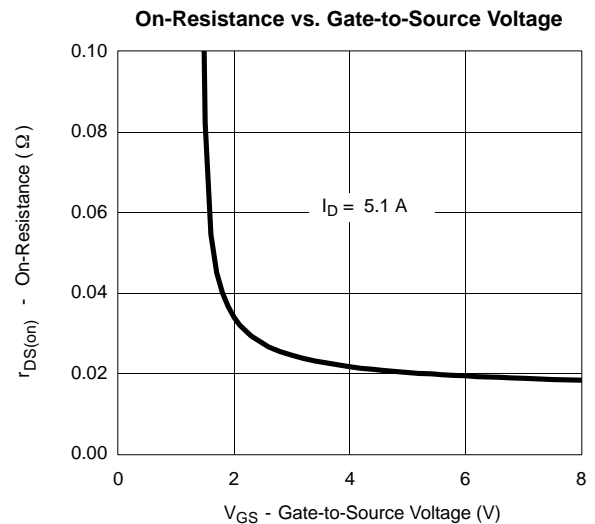
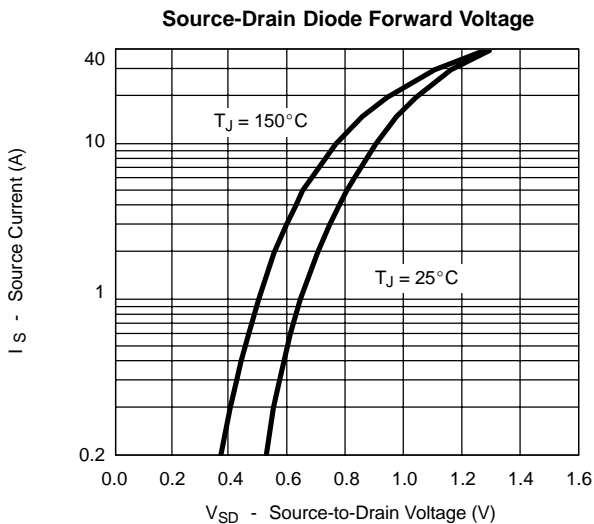
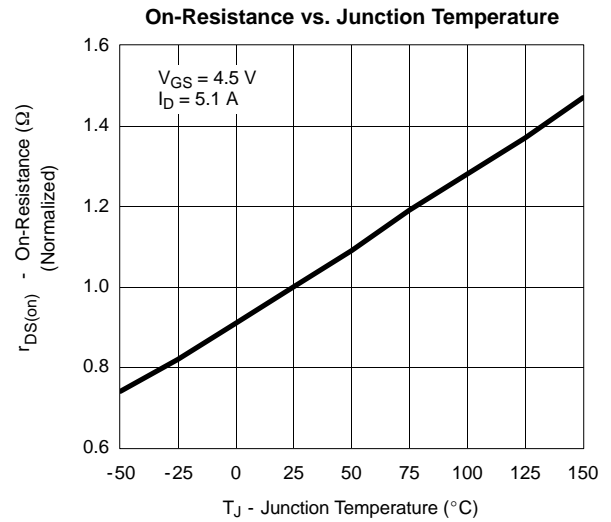
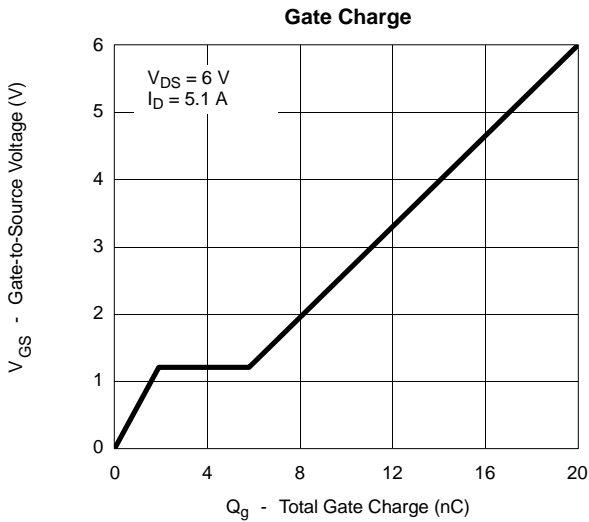
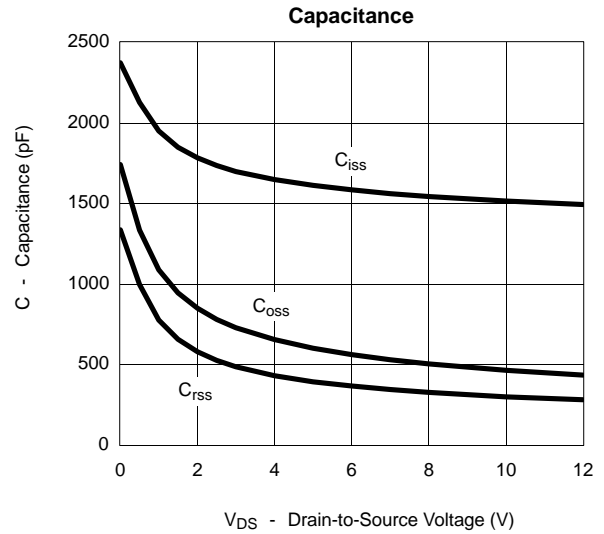
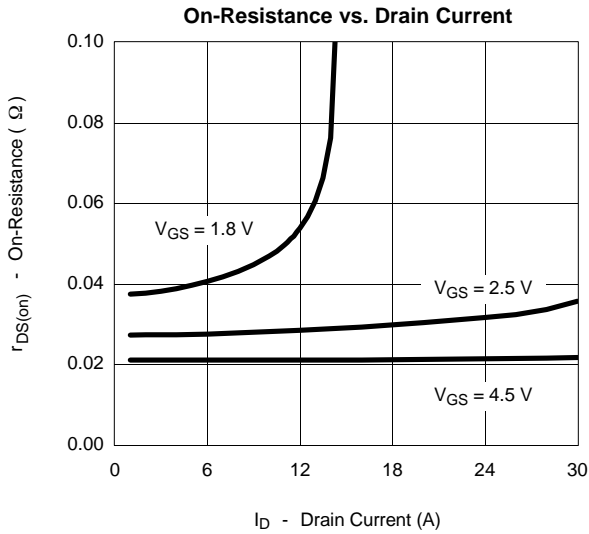



TYPICAL CHARACTERISTICS (25°C UNLESS NOTED)

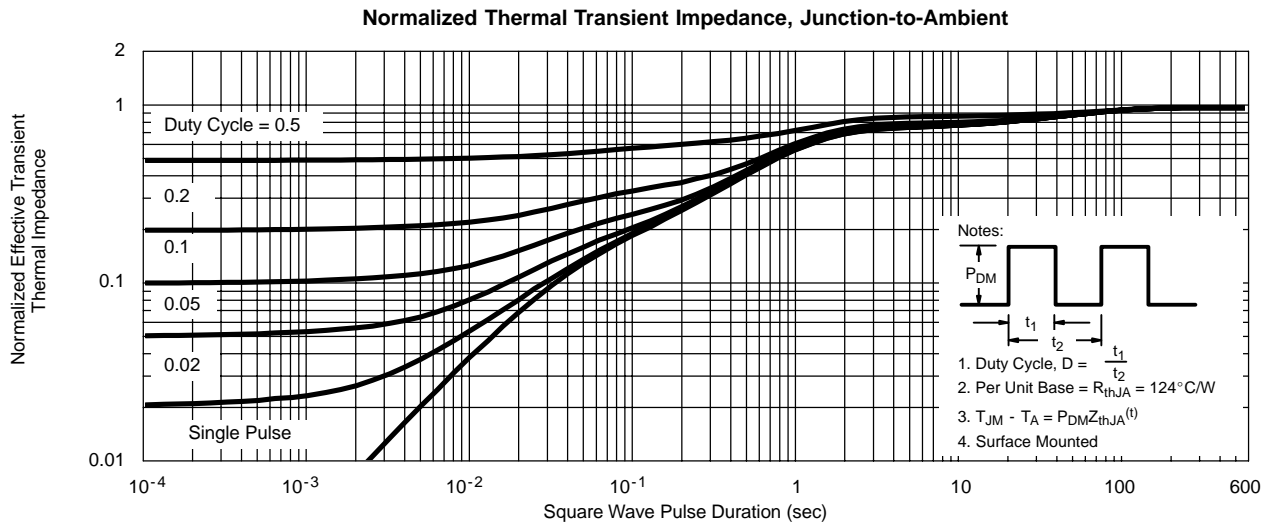
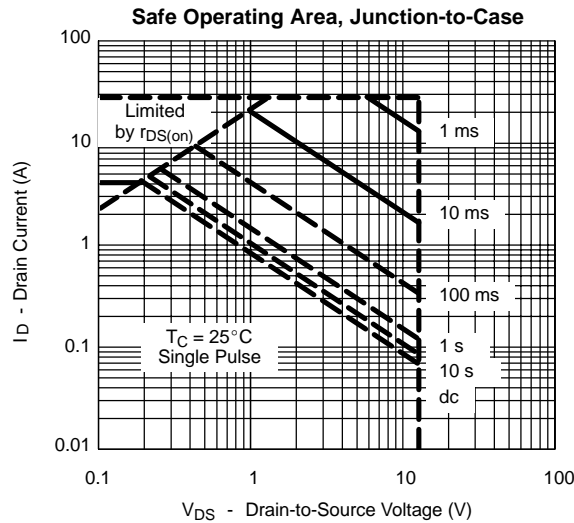
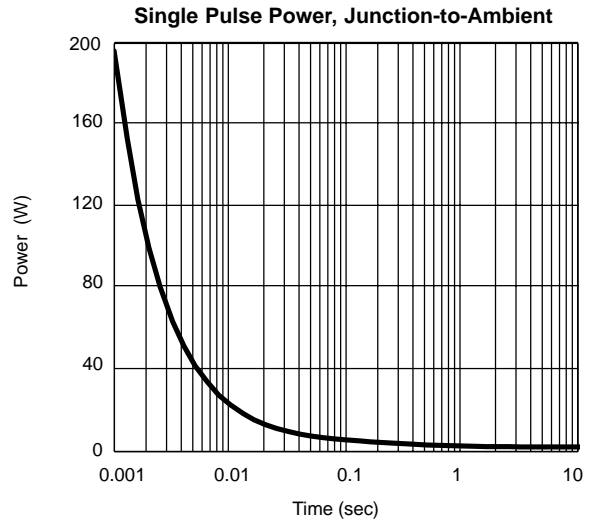
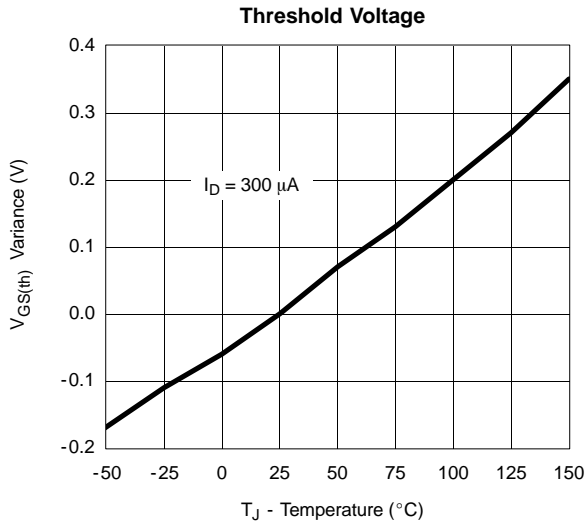



New Product

Si6911DQ
Vishay Siliconix

TYPICAL CHARACTERISTICS (25°C UNLESS NOTED)

