



# LT1167

## Single Resistor Gain Programmable, Precision Instrumentation Amplifier

### FEATURES

- **Single Gain Set Resistor:  $G = 1$  to 10,000**
- **Gain Error:  $G = 10$ , 0.08% Max**
- **Gain Nonlinearity:  $G = 10$ , 10ppm Max**
- **Input Offset Voltage:  $G = 10$ , 60 $\mu$ V Max**
- **Input Offset Voltage Drift: 0.3 $\mu$ V/ $^{\circ}$ C Max**
- **Input Bias Current: 350pA Max**
- **PSRR at  $G = 1$ : 105dB Min**
- **CMRR at  $G = 1$ : 90dB Min**
- **Supply Current: 1.3mA Max**
- **Wide Supply Range:  $\pm 2.3V$  to  $\pm 18V$**
- **1kHz Voltage Noise: 7.5nV/ $\sqrt{Hz}$**
- **0.1Hz to 10Hz Noise: 0.28 $\mu$ V<sub>P-P</sub>**
- **Available in 8-Pin PDIP and SO Packages**
- **Meets IEC 1000-4-2 Level 4 ESD Tests with Two External 5k Resistors**

### APPLICATIONS

- Bridge Amplifiers
- Strain Gauge Amplifiers
- Thermocouple Amplifiers
- Differential to Single-Ended Converters
- Medical Instrumentation

### DESCRIPTION

The LT<sup>®</sup>1167 is a low power, precision instrumentation amplifier that requires only one external resistor to set gains of 1 to 10,000. The low voltage noise of 7.5nV/ $\sqrt{Hz}$  (at 1kHz) is not compromised by low power dissipation (0.9mA typical for  $\pm 2.3V$  to  $\pm 15V$  supplies).

The high accuracy of 10ppm maximum nonlinearity and 0.08% max gain error ( $G = 10$ ) is not degraded even for load resistors as low as 2k (previous monolithic instrumentation amps used 10k for their nonlinearity specifications). The LT1167 is laser trimmed for very low input offset voltage (40 $\mu$ V max), drift (0.3 $\mu$ V/ $^{\circ}$ C), high CMRR (90dB,  $G = 1$ ) and PSRR (105dB,  $G = 1$ ). Low input bias currents of 350pA max are achieved with the use of superbeta processing. The output can handle capacitive loads up to 1000pF in any gain configuration while the inputs are ESD protected up to 13kV (human body). The LT1167 with two external 5k resistors passes the IEC 1000-4-2 level 4 specification.

The LT1167, offered in 8-pin PDIP and SO packages, requires significantly less PC board area than discrete multi op amp and resistor designs. These advantages make the LT1167 the most cost effective solution for precision instrumentation amplifier applications.

LT, LTC and LT are registered trademarks of Linear Technology Corporation.

### TYPICAL APPLICATION

Single Supply Barometer

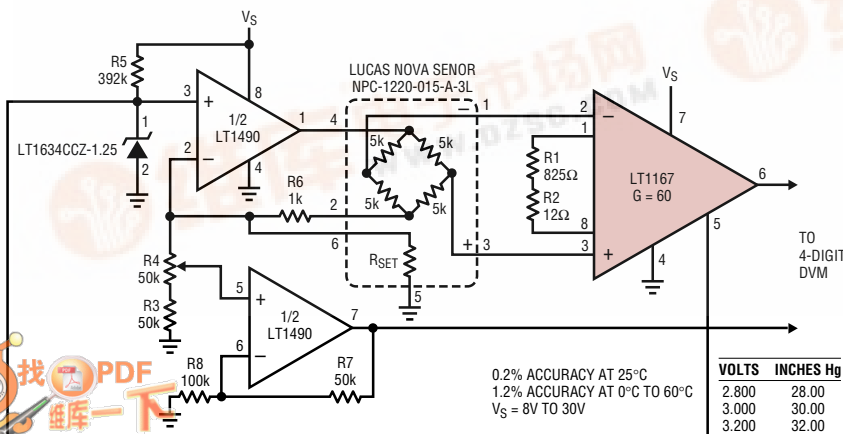

Gain Nonlinearity

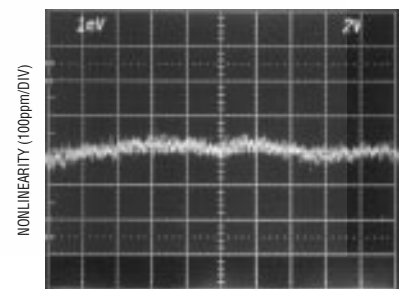

$G = 1000$   
 $R_L = 1k$   
 $V_{OUT} = \pm 10V$

1167 TA02



# LT1167

## ABSOLUTE MAXIMUM RATINGS

(Note 1)

Supply Voltage .....	±20V
Differential Input Voltage (Within the Supply Voltage) .....	±40V
Input Voltage (Equal to Supply Voltage) .....	±20V
Input Current (Note 3) .....	±20mA
Output Short-Circuit Duration .....	Indefinite
Operating Temperature Range .....	-40°C to 85°C
Specified Temperature Range	
LT1167AC/LT1167C (Note 4) .....	0°C to 70°C
LT1167AI/LT1167I .....	-40°C to 85°C
Storage Temperature Range .....	-65°C to 150°C
Lead Temperature (Soldering, 10 sec) .....	300°C

## PACKAGE/ORDER INFORMATION

	ORDER PART NUMBER	
	LT1167ACN8 LT1167ACS8 LT1167AIN8 LT1167AIS8 LT1167CN8 LT1167CS8 LT1167IN8 LT1167IS8	
	S8 PART MARKING	
	1167A	1167
	1167AI	1167I

Consult factory for Military grade parts.

## ELECTRICAL CHARACTERISTICS

$V_S = \pm 15V$ ,  $V_{CM} = 0V$ ,  $T_A = 25^\circ C$ ,  $R_L = 2k$ , unless otherwise noted.

SYMBOL	PARAMETER	CONDITIONS (Note 7)	LT1167AC/LT1167AI			LT1167C/LT1167I			UNITS	
			MIN	TYP	MAX	MIN	TYP	MAX		
G	Gain Range	$G = 1 + (49.4k/R_G)$	1		10k	1		10k		
	Gain Error	$G = 1$		0.008	0.02		0.015	0.03	%	
		$G = 10$ (Note 2)			0.010	0.08		0.020	0.10	%
		$G = 100$ (Note 2)			0.025	0.08		0.030	0.10	%
		$G = 1000$ (Note 2)			0.040	0.10		0.040	0.10	%
Gain Nonlinearity (Note 5)	$V_O = \pm 10V$ , $G = 1$			1	6		1.5	10	ppm	
	$V_O = \pm 10V$ , $G = 10$ and 100			2	10		3	15	ppm	
	$V_O = \pm 10V$ , $G = 1000$			15	40		20	60	ppm	
	$V_O = \pm 10V$ , $G = 1$ , $R_L = 600$			5	12		6	15	ppm	
	$V_O = \pm 10V$ , $G = 10$ and 100, $R_L = 600$			6	15		7	20	ppm	
	$V_O = \pm 10V$ , $G = 1000$ , $R_L = 600$			20	65		25	80	ppm	
$V_{OST}$	Total Input Referred Offset Voltage	$V_{OST} = V_{OSI} + V_{OSO}/G$								
$V_{OSI}$	Input Offset Voltage	$G = 1000$ , $V_S = \pm 5V$ to $\pm 15V$		15	40		20	60	μV	
$V_{OSO}$	Output Offset Voltage	$G = 1$ , $V_S = \pm 5V$ to $\pm 15V$		40	200		50	300	μV	
$I_{OS}$	Input Offset Current			90	320		100	450	pA	
$I_B$	Input Bias Current			50	350		80	500	pA	
$e_n$	Input Noise Voltage, RTI	0.1Hz to 10Hz, $G = 1$		2.00			2.00		μV <sub>P-P</sub>	
		0.1Hz to 10Hz, $G = 10$		0.50			0.50		μV <sub>P-P</sub>	
		0.1Hz to 10Hz, $G = 100$ and 1000		0.28			0.28		μV <sub>P-P</sub>	
Total RTI Noise = $\sqrt{e_{ni}^2 + (e_{no}/G)^2}$										
$e_{ni}$	Input Noise Voltage Density, RTI	$f_0 = 1kHz$		7.5	12		7.5	12	nV/√Hz	
$e_{no}$	Output Noise Voltage Density, RTI	$f_0 = 1kHz$ (Note 3)		67	90		67	90	nV/√Hz	

**ELECTRICAL CHARACTERISTICS**  $V_S = \pm 15V$ ,  $V_{CM} = 0V$ ,  $T_A = 25^\circ C$ ,  $R_L = 2k$ , unless otherwise noted.

SYMBOL	PARAMETER	CONDITIONS (Note 7)	LT1167AC/LT1167AI			LT1167C/LT1167I			UNITS
			MIN	TYP	MAX	MIN	TYP	MAX	
$i_n$	Input Noise Current	$f_0 = 0.1\text{Hz to } 10\text{Hz}$	10			10			pA <sub>p-p</sub>
	Input Noise Current Density	$f_0 = 10\text{Hz}$	124			124			fA/ $\sqrt{\text{Hz}}$
$R_{IN}$	Input Resistance	$V_{IN} = \pm 10V$	200	1000		200	1000	G $\Omega$	
$C_{IN(DIFF)}$	Differential Input Capacitance	$f_0 = 100\text{kHz}$	1.6			1.6			pF
$C_{IN(CM)}$	Common Mode Input Capacitance	$f_0 = 100\text{kHz}$	1.6			1.6			pF
$V_{CM}$	Input Voltage Range	$G = 1$ , Other Input Grounded							
		$V_S = \pm 2.3V \text{ to } \pm 5V$ $V_S = \pm 5V \text{ to } \pm 18V$	$-V_S + 1.9$ $-V_S + 1.9$	$+V_S - 1.2$ $+V_S - 1.4$		$-V_S + 1.9$ $-V_S + 1.9$	$+V_S - 1.2$ $+V_S - 1.4$		V V
CMRR	Common Mode Rejection Ratio	1k Source Imbalance, $V_{CM} = 0V \text{ to } \pm 10V$							
		$G = 1$	90	95		85	95		dB
		$G = 10$	106	115		100	115		dB
		$G = 100$	120	125		110	125		dB
PSRR	Power Supply Rejection Ratio	$V_S = \pm 2.3 \text{ to } \pm 18V$							
		$G = 1$	105	120		100	120		dB
		$G = 10$	125	135		120	135		dB
		$G = 100$	131	140		126	140		dB
$I_S$	Supply Current	$V_S = \pm 2.3V \text{ to } \pm 18V$		0.9	1.3		0.9	1.3	mA
$V_{OUT}$	Output Voltage Swing	$R_L = 10k$							
		$V_S = \pm 2.3V \text{ to } \pm 5V$ $V_S = \pm 5V \text{ to } \pm 18V$	$-V_S + 1.1$ $-V_S + 1.2$	$+V_S - 1.2$ $+V_S - 1.3$		$-V_S + 1.1$ $-V_S + 1.2$	$+V_S - 1.2$ $+V_S - 1.3$		V V
$I_{OUT}$	Output Current		20	27		20	27	mA	
BW	Bandwidth	$G = 1$	1000			1000			kHz
		$G = 10$	800			800			kHz
		$G = 100$	120			120			kHz
		$G = 1000$	12			12			kHz
SR	Slew Rate	$G = 1$ , $V_{OUT} = \pm 10V$	0.75	1.2		0.75	1.2	V/ $\mu\text{s}$	
	Settling Time to 0.01%	10V Step $G = 1 \text{ to } 100$ $G = 1000$		14 130			14 130	$\mu\text{s}$ $\mu\text{s}$	
$R_{REFIN}$	Reference Input Resistance		20			20			k $\Omega$
$I_{REFIN}$	Reference Input Current	$V_{REF} = 0V$	50			50			$\mu\text{A}$
$V_{REF}$	Reference Voltage Range		$-V_S + 1.6$	$+V_S - 1.6$		$-V_S + 1.6$	$+V_S - 1.6$	V	
$A_{VREF}$	Reference Gain to Output		$1 \pm 0.0001$			$1 \pm 0.0001$			

# LT1167

## ELECTRICAL CHARACTERISTICS $V_S = \pm 15V$ , $V_{CM} = 0V$ , $0^\circ C \leq T_A \leq 70^\circ C$ , $R_L = 2k$ , unless otherwise noted.

SYMBOL	PARAMETER	CONDITIONS (Note 7)		LT1167AC			LT1167C			UNITS
				MIN	TYP	MAX	MIN	TYP	MAX	
	Gain Error	G = 1	●	0.01	0.03	0.012	0.04	%		
		G = 10 (Note 2)	●	0.08	0.30	0.100	0.33	%		
		G = 100 (Note 2)	●	0.09	0.30	0.120	0.33	%		
		G = 1000 (Note 2)	●	0.14	0.33	0.140	0.35	%		
	Gain Nonlinearity	$V_{OUT} = \pm 10V$ , G = 1	●	1.5	10	2	15	ppm		
		$V_{OUT} = \pm 10V$ , G = 10 and 100	●	3	15	4	20	ppm		
		$V_{OUT} = \pm 10V$ , G = 1000	●	20	60	25	80	ppm		
G/T	Gain vs Temperature	G < 1000 (Note 2)	●	20	50	20	50	ppm/°C		
$V_{OST}$	Total Input Referred Offset Voltage	$V_{OST} = V_{OSI} + V_{OSO}/G$								
$V_{OSI}$	Input Offset Voltage	$V_S = \pm 5V$ to $\pm 15V$	●	18	60	23	80	$\mu V$		
$V_{OSIH}$	Input Offset Voltage Hysteresis	(Notes 3, 6)		3.0		3.0		$\mu V$		
$V_{OSO}$	Output Offset Voltage	$V_S = \pm 5V$ to $\pm 15V$	●	60	380	70	500	$\mu V$		
$V_{OSOH}$	Output Offset Voltage Hysteresis	(Notes 3, 6)		30		30		$\mu V$		
$V_{OSI}/T$	Input Offset Drift (RTI)	(Note 3)	●	0.05	0.3	0.06	0.4	$\mu V/^\circ C$		
$V_{OSO}/T$	Output Offset Drift	(Note 3)	●	0.7	3	0.8	4	$\mu V/^\circ C$		
$I_{OS}$	Input Offset Current		●	100	400	120	550	pA		
$I_{OS}/T$	Input Offset Current Drift		●	0.3		0.4		pA/°C		
$I_B$	Input Bias Current		●	75	450	105	600	pA		
$I_B/T$	Input Bias Current Drift		●	0.4		0.4		pA/°C		
$V_{CM}$	Input Voltage Range	G = 1, Other Input Grounded								
		$V_S = \pm 2.3V$ to $\pm 5V$	●	$-V_S + 2.1$	$+V_S - 1.3$	$-V_S + 2.1$	$+V_S - 1.3$	V		
		$V_S = \pm 5V$ to $\pm 18V$	●	$-V_S + 2.1$	$+V_S - 1.4$	$-V_S + 2.1$	$+V_S - 1.4$	V		
CMRR	Common Mode Rejection Ratio	1k Source Imbalance, $V_{CM} = 0V$ to $\pm 10V$								
		G = 1	●	88	92	83	92	dB		
		G = 10	●	100	110	97	110	dB		
		G = 100	●	115	120	113	120	dB		
		G = 1000	●	117	135	114	135	dB		
PSRR	Power Supply Rejection Ratio	$V_S = \pm 2.3V$ to $\pm 18V$								
		G = 1	●	103	115	98	115	dB		
		G = 10	●	123	130	118	130	dB		
		G = 100	●	127	135	124	135	dB		
		G = 1000	●	129	145	126	145	dB		
$I_S$	Supply Current	$V_S = \pm 2.3V$ to $\pm 18V$	●	1.0	1.5	1.0	1.5	mA		
$V_{OUT}$	Output Voltage Swing	$R_L = 10k$								
		$V_S = \pm 2.3V$ to $\pm 5V$	●	$-V_S + 1.4$	$+V_S - 1.3$	$-V_S + 1.4$	$+V_S - 1.3$	V		
		$V_S = \pm 5V$ to $\pm 18V$	●	$-V_S + 1.6$	$+V_S - 1.5$	$-V_S + 1.6$	$+V_S - 1.5$	V		
$I_{OUT}$	Output Current		●	16	21	16	21	mA		
SR	Slew Rate	G = 1, $V_{OUT} = \pm 10V$	●	0.65	1.1	0.65	1.1	V/ $\mu s$		
$V_{REF}$	REF Voltage Range	(Note 3)	●	$-V_S + 1.6$	$+V_S - 1.6$	$-V_S + 1.6$	$+V_S - 1.6$	V		

## ELECTRICAL CHARACTERISTICS

$V_S = \pm 15V$ ,  $V_{CM} = 0V$ ,  $-40^\circ C \leq T_A \leq 85^\circ C$ ,  $R_L = 2k$ , unless otherwise noted. (Note 4)

SYMBOL	PARAMETER	CONDITIONS (Note 7)		LT1167AI			LT1167I			UNITS
				MIN	TYP	MAX	MIN	TYP	MAX	
	Gain Error	G = 1 G = 10 (Note 2) G = 100 (Note 2) G = 1000 (Note 2)	● ● ● ●	0.014 0.130 0.140 0.160	0.04 0.40 0.40 0.40	0.015 0.140 0.150 0.180	0.05 0.42 0.42 0.45	% % % %		
$G_N$	Gain Nonlinearity (Notes 2, 4)	$V_O = \pm 10V$ , G = 1 $V_O = \pm 10V$ , G = 10 and 100 $V_O = \pm 10V$ , G = 1000	● ● ●	2 5 26	15 20 70	3 6 30	20 30 100	ppm ppm ppm		
G/T	Gain vs Temperature	G < 1000 (Note 2)	●	20	50	20	50	ppm/°C		
$V_{OST}$	Total Input Referred Offset Voltage	$V_{OST} = V_{OSI} + V_{OSO}/G$								
$V_{OSI}$	Input Offset Voltage		●	20	75	25	100	μV		
$V_{OSIH}$	Input Offset Voltage Hysteresis	(Notes 3, 6)		3.0		3.0		μV		
$V_{OSO}$	Output Offset Voltage		●	180	500	200	600	μV		
$V_{OSOH}$	Output Offset Voltage Hysteresis	(Notes 3, 6)		30		30		μV		
$V_{OSI}/T$	Input Offset Drift (RTI)	(Note 3)	●	0.05	0.3	0.06	0.4	μV/°C		
$V_{OSO}/T$	Output Offset Drift	(Note 3)	●	0.8	5	1	6	μV/°C		
$I_{OS}$	Input Offset Current		●	110	550	120	700	pA		
$I_{OS}/T$	Input Offset Current Drift		●	0.3		0.3		pA/°C		
$I_B$	Input Bias Current		●	180	600	220	800	pA		
$I_B/T$	Input Bias Current Drift		●	0.5		0.6		pA/°C		
$V_{CM}$	Input Voltage Range	$V_S = \pm 2.3V$ to $\pm 5V$ $V_S = \pm 5V$ to $\pm 18V$	● ●	$-V_S + 2.1$ $-V_S + 2.1$	$+V_S - 1.3$ $+V_S - 1.4$	$-V_S + 2.1$ $-V_S + 2.1$	$+V_S - 1.3$ $+V_S - 1.4$	V V		
CMRR	Common Mode Rejection Ratio	1k Source Imbalance, $V_{CM} = 0V$ to $\pm 10V$ G = 1 G = 10 G = 100 G = 1000	● ● ● ●	86 98 114 116	90 105 118 133	81 95 112 112	90 105 118 133	dB dB dB dB		
PSRR	Power Supply Rejection Ratio	$V_S = \pm 2.3V$ to $\pm 18V$ G = 1 G = 10 G = 100 G = 1000	● ● ● ●	100 120 125 128	112 125 132 140	95 115 120 125	112 125 132 140	dB dB dB dB		
$I_S$	Supply Current		●	1.1	1.6	1.1	1.6	mA		
$V_{OUT}$	Output Voltage Swing	$V_S = \pm 2.3V$ to $\pm 5V$ $V_S = \pm 5V$ to $\pm 18V$	● ●	$-V_S + 1.4$ $-V_S + 1.6$	$+V_S - 1.3$ $+V_S - 1.5$	$-V_S + 1.4$ $-V_S + 1.6$	$+V_S - 1.3$ $+V_S - 1.5$	V V		
$I_{OUT}$	Output Current		●	15	20	15	20	mA		
SR	Slew Rate	G = 1, $V_{OUT} = \pm 10V$	●	0.55	0.95	0.55	0.95	V/μs		
$V_{REF}$	REF Voltage Range	(Note 3)	●	$-V_S + 1.6$	$+V_S - 1.6$	$-V_S + 1.6$	$+V_S - 1.6$	V		

The ● denotes specifications that apply over the full specified temperature range.

**Note 1:** Absolute Maximum Ratings are those values beyond which the life of a device may be impaired.

**Note 2:** Does not include the effect of the external gain resistor  $R_G$ .

**Note 3:** This parameter is not 100% tested.

**Note 4:** The LT1167AC/LT1167C are designed, characterized and expected to meet the industrial temperature limits, but are not tested at  $-40^\circ C$  and  $85^\circ C$ . I-grade parts are guaranteed.

**Note 5:** This parameter is measured in a high speed automatic tester that does not measure the thermal effects with longer time constants. The

magnitude of these thermal effects are dependent on the package used, heat sinking and air flow conditions.

**Note 6:** Hysteresis in offset voltage is created by package stress that differs depending on whether the IC was previously at a higher or lower temperature. Offset voltage hysteresis is always measured at  $25^\circ C$ , but the IC is cycled to  $85^\circ C$  I-grade (or  $70^\circ C$  C-grade) or  $-40^\circ C$  I-grade ( $0^\circ C$  C-grade) before successive measurement. 60% of the parts will pass the typical limit on the data sheet.

**Note 7:** Typical parameters are defined as the 60% of the yield parameter distribution.

# TYPICAL PERFORMANCE CHARACTERISTICS

**Gain Nonlinearity, G = 1**

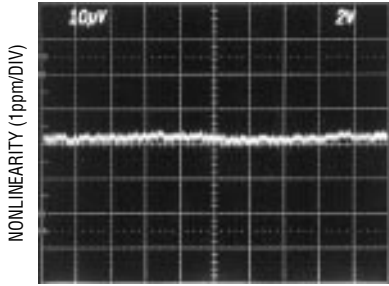

G = 1 OUTPUT VOLTAGE (2V/DIV) 1167 G01  
 $R_L = 2k$   
 $V_{OUT} = \pm 10V$

**Gain Nonlinearity, G = 10**

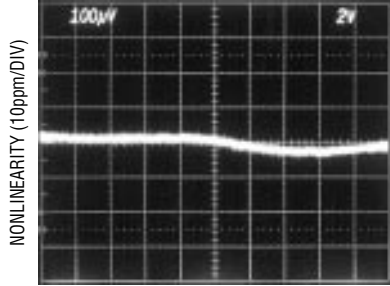

G = 10 OUTPUT VOLTAGE (2V/DIV) 1167 G02  
 $R_L = 2k$   
 $V_{OUT} = \pm 10V$

**Gain Nonlinearity, G = 100**

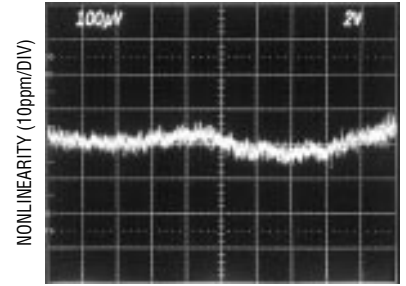

G = 100 OUTPUT VOLTAGE (2V/DIV) 1167 G03  
 $R_L = 2k$   
 $V_{OUT} = \pm 10V$

**Gain Nonlinearity, G = 1000**

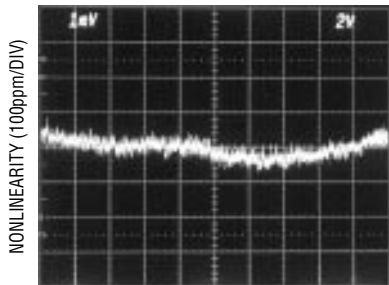

G = 1000 OUTPUT VOLTAGE (2V/DIV) 1167 G04  
 $R_L = 2k$   
 $V_{OUT} = \pm 10V$

**Gain Nonlinearity vs Temperature**

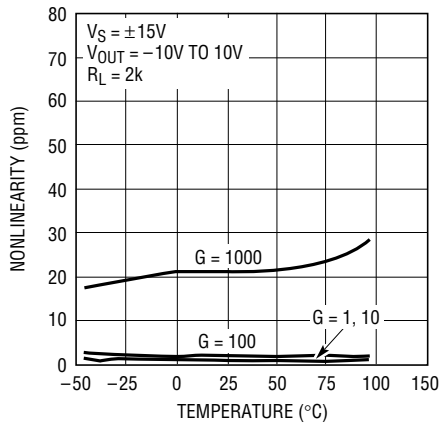

1167 G05

**Gain Error vs Temperature**

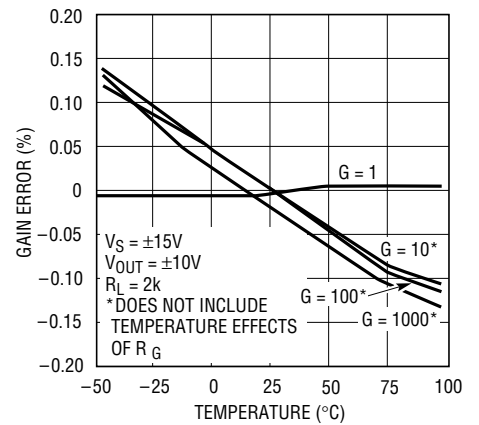

1167 G06

**Distribution of Input Offset Voltage,  $T_A = -40^\circ C$**

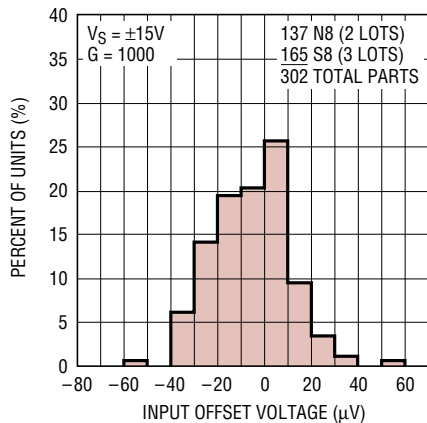

1167 G40

**Distribution of Input Offset Voltage,  $T_A = 25^\circ C$**

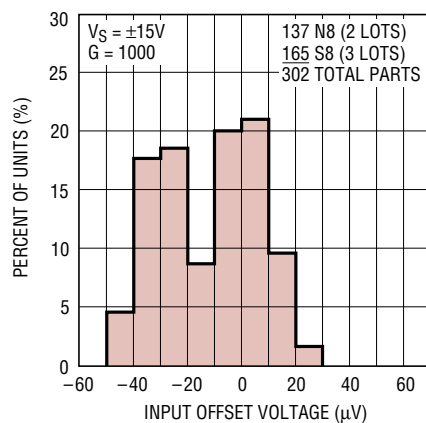

1167 G41

**Distribution of Input Offset Voltage,  $T_A = 85^\circ C$**

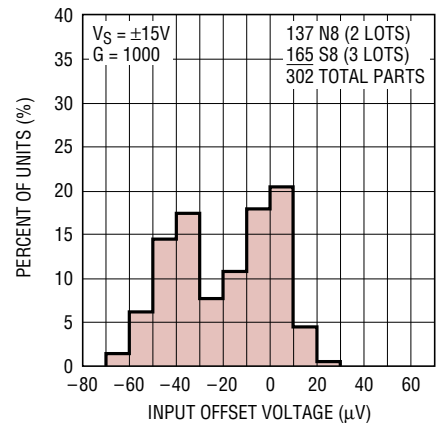

1167 G42

# TYPICAL PERFORMANCE CHARACTERISTICS

**Distribution of Output Offset Voltage,  $T_A = -40^\circ\text{C}$**

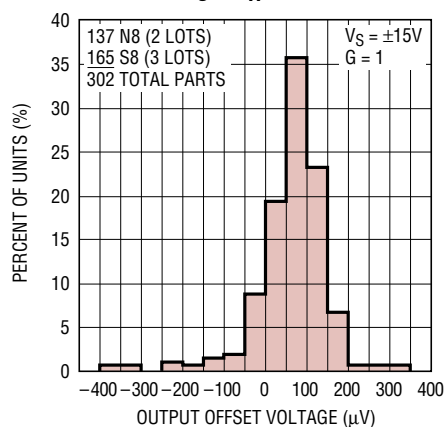

1167 G43

**Distribution of Output Offset Voltage,  $T_A = 25^\circ\text{C}$**

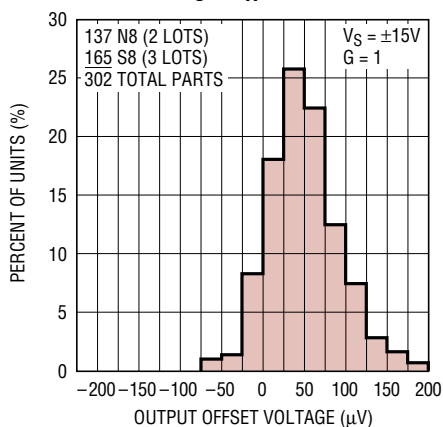

1167 G44

**Distribution of Output Offset Voltage,  $T_A = 85^\circ\text{C}$**

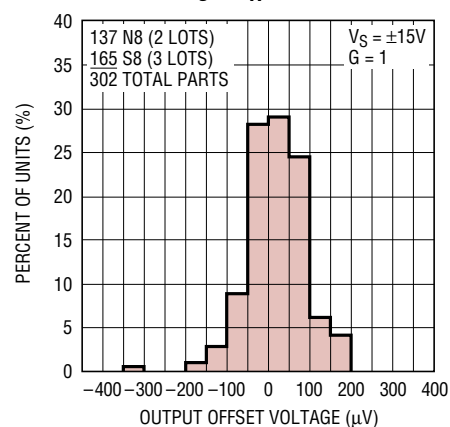

1167 G45

**Distribution of Input Offset Voltage Drift**

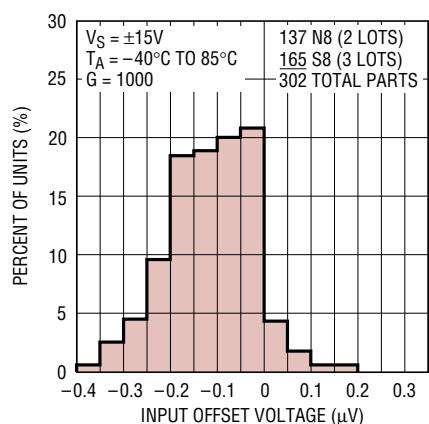

1167 G46

**Distribution of Output Offset Voltage Drift**

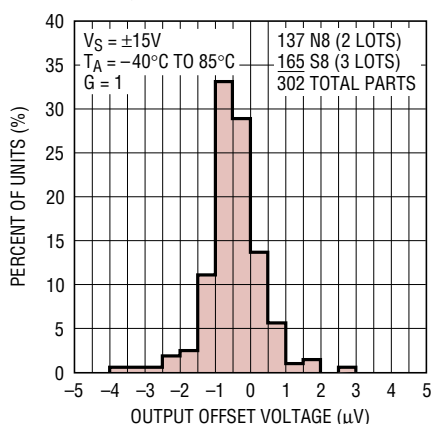

1167 G47

**Warm-Up Drift**

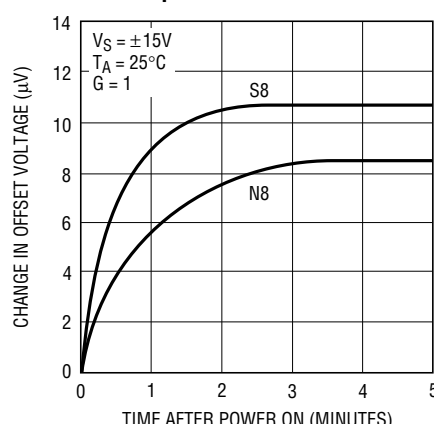

1167 G09

**Input Bias Current**

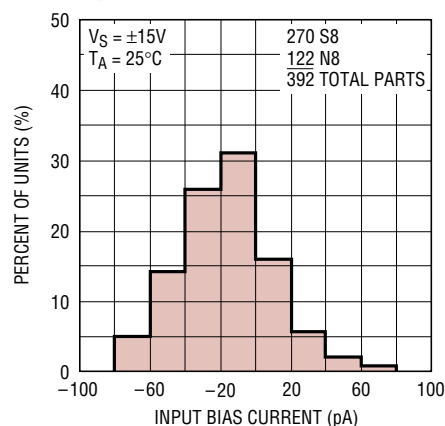

1167 G10

**Input Offset Current**

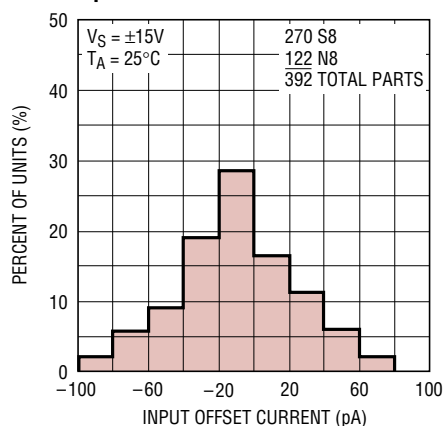

1167 G11

**Input Bias and Offset Current vs Temperature**

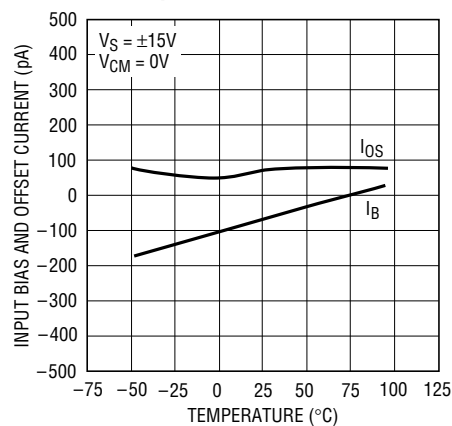

1167 G12

# TYPICAL PERFORMANCE CHARACTERISTICS

**Input Bias Current vs Common Mode Input Voltage**

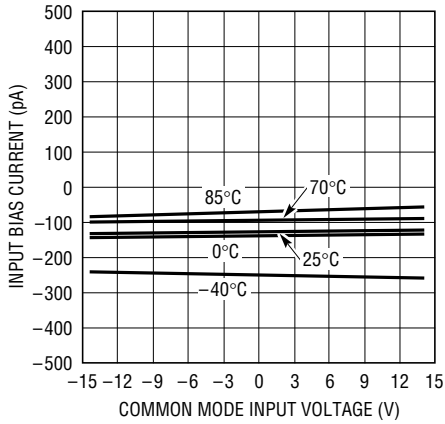

1167 G13

**Common Mode Rejection Ratio vs Frequency**

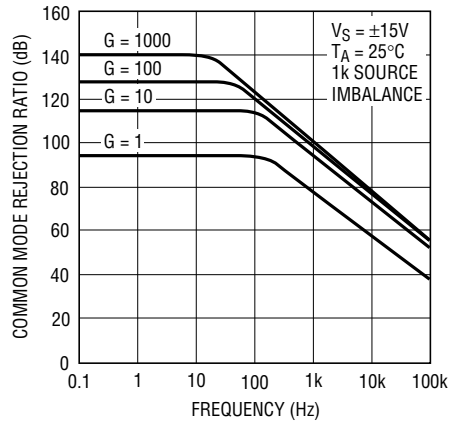

1167 G14

**Negative Power Supply Rejection Ratio vs Frequency**

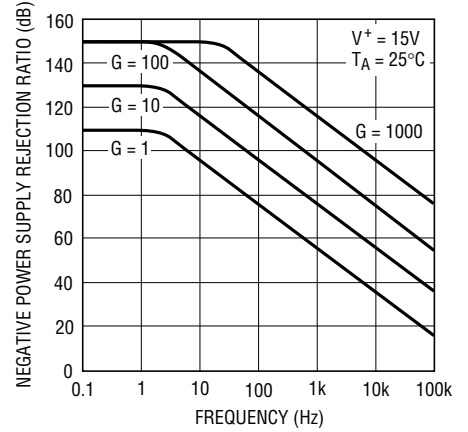

1167 G15

**Positive Power Supply Rejection Ratio vs Frequency**

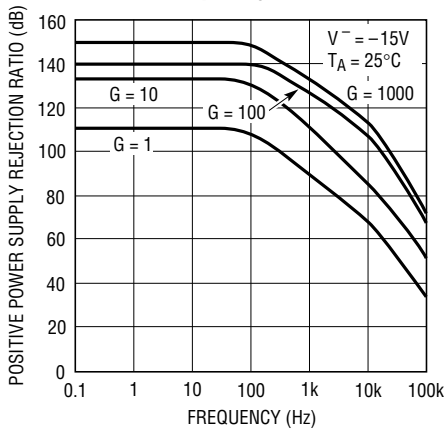

1167 G16

**Gain vs Frequency**

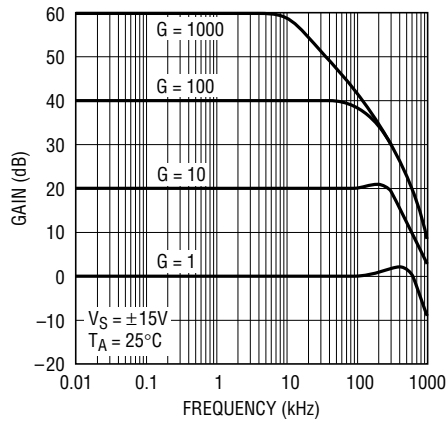

1167 G17

**Supply Current vs Supply Voltage**

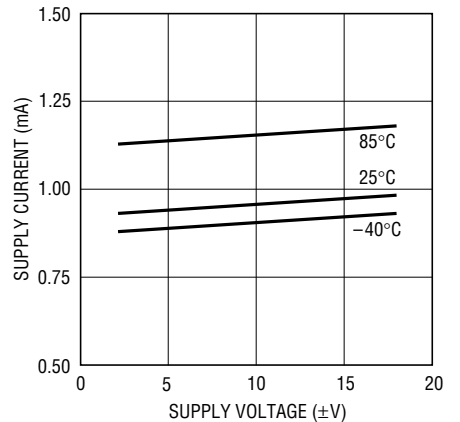

1167 G18

**Voltage Noise Density vs Frequency**

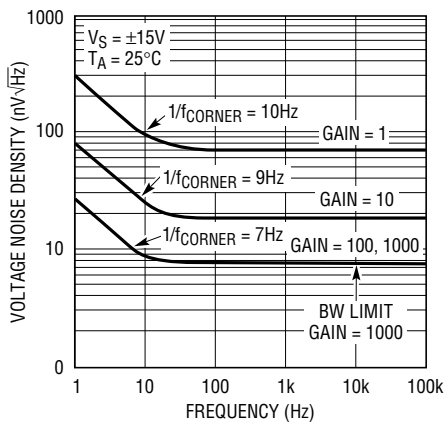

1167 G19

**0.1Hz to 10Hz Noise Voltage, G = 1**

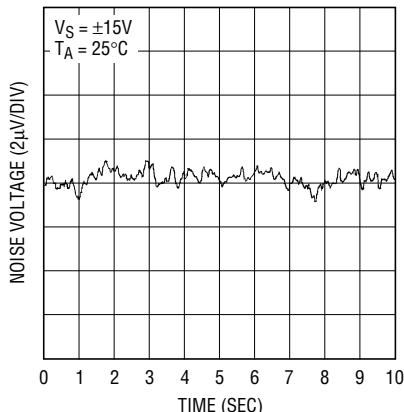

1167 G20

**0.1Hz to 10Hz Noise Voltage, RTI G = 1000**

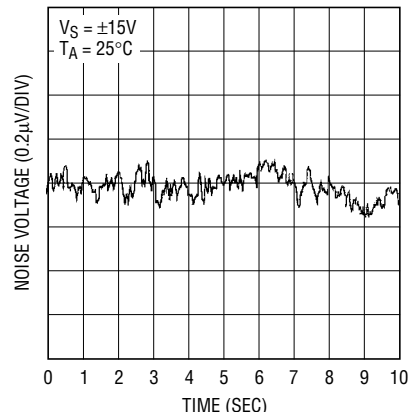

1167 G21

# TYPICAL PERFORMANCE CHARACTERISTICS

**Current Noise Density vs Frequency**

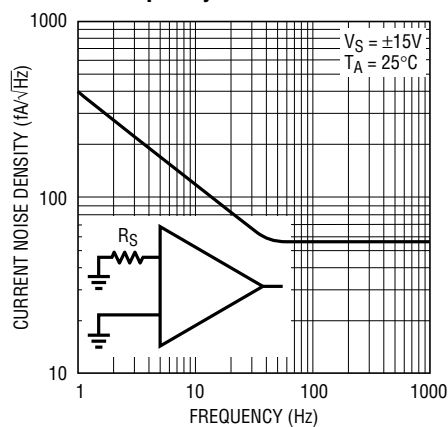

1167 G22

**0.1Hz to 10Hz Current Noise**

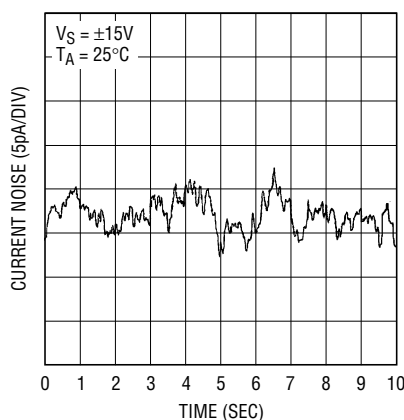

1167 G23

**Short-Circuit Current vs Time**

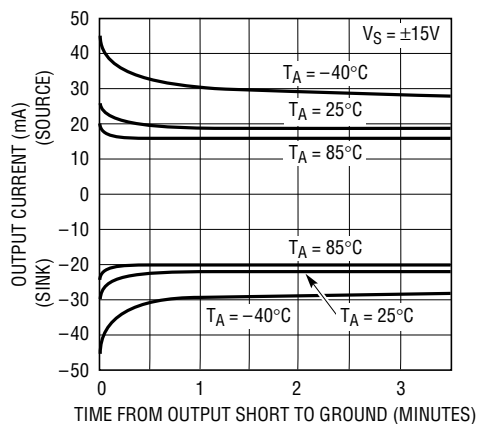

1167 G24

**Overshoot vs Capacitive Load**

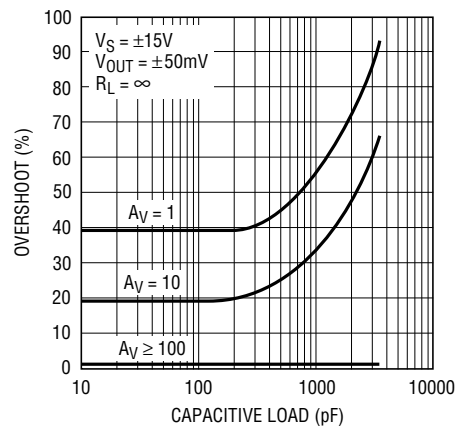

1167 G25

**Large-Signal Transient Response**

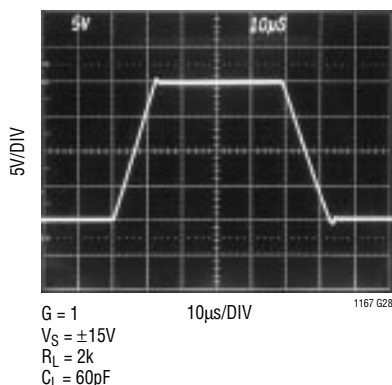

1167 G28

**Small-Signal Transient Response**

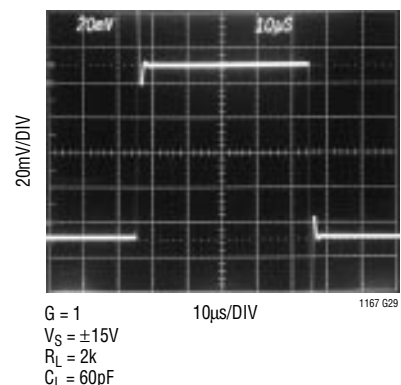

1167 G29

**Output Impedance vs Frequency**

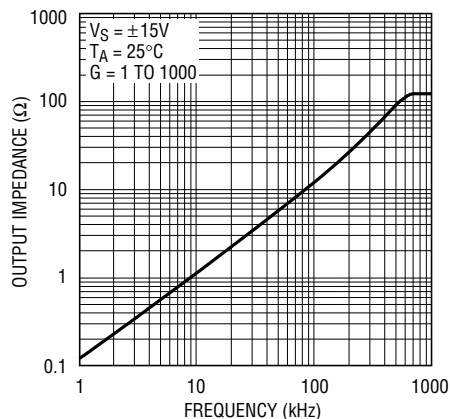

1167 G26

**Large-Signal Transient Response**

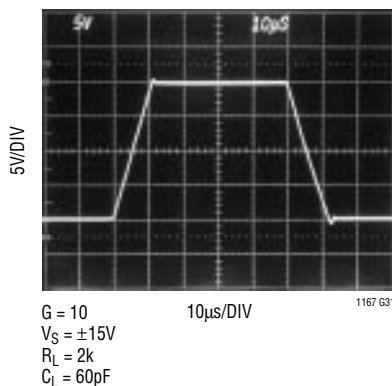

1167 G31

**Small-Signal Transient Response**

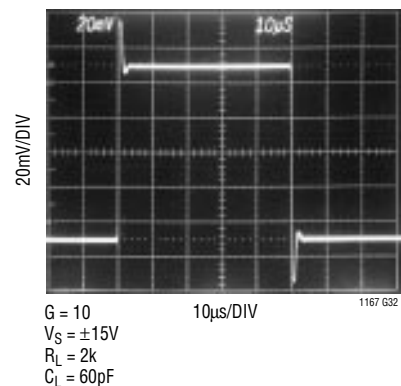

1167 G32

# TYPICAL PERFORMANCE CHARACTERISTICS

**Undistorted Output Swing vs Frequency**

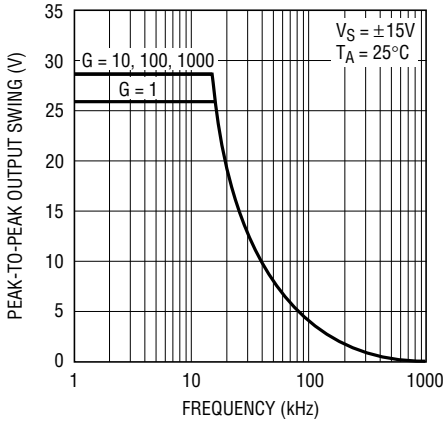

1167 G27

**Large-Signal Transient Response**

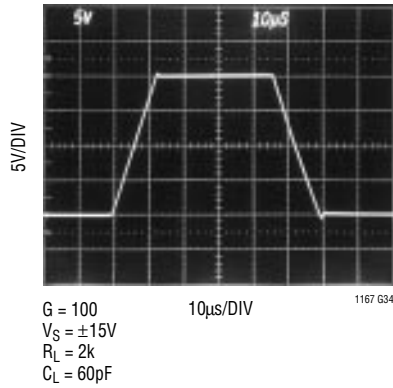

1167 G34

**Small-Signal Transient Response**

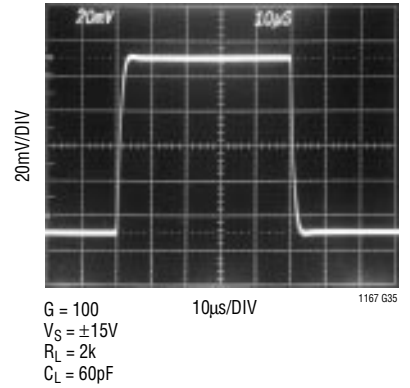

1167 G35

**Settling Time vs Gain**

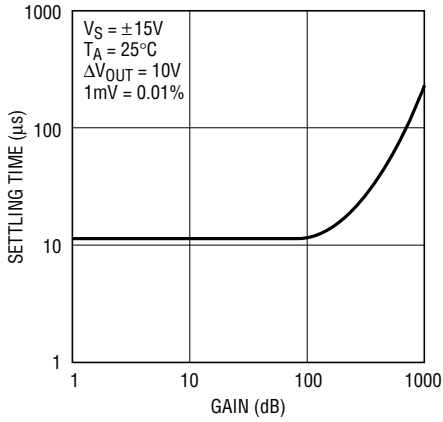

1167 G30

**Large-Signal Transient Response**

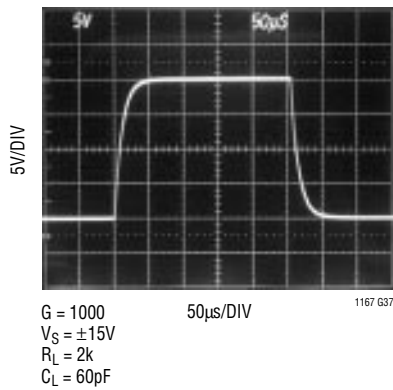

1167 G37

**Small-Signal Transient Response**

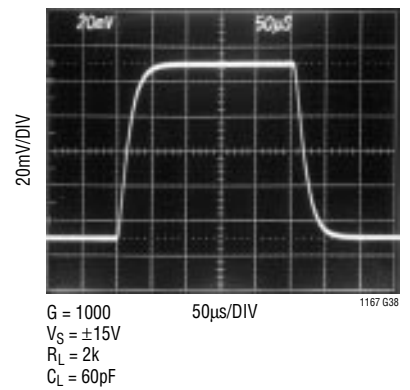

1167 G38

**Settling Time vs Step Size**

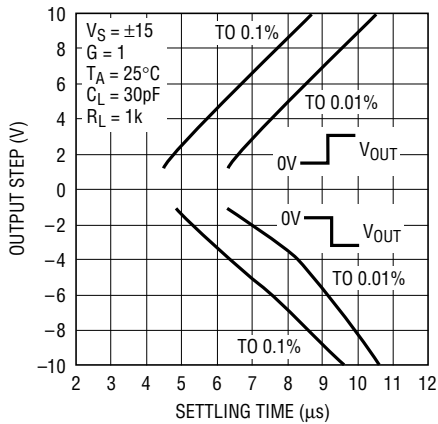

1167 G33

**Slew Rate vs Temperature**

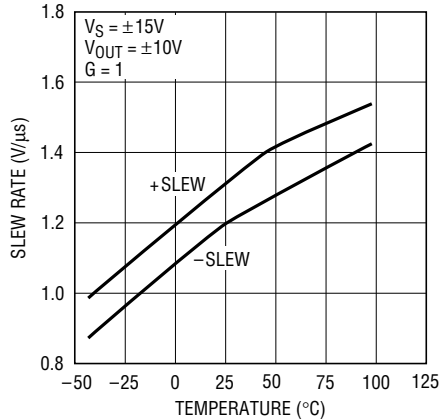

1167 G36

**Output Voltage Swing vs Load Current**

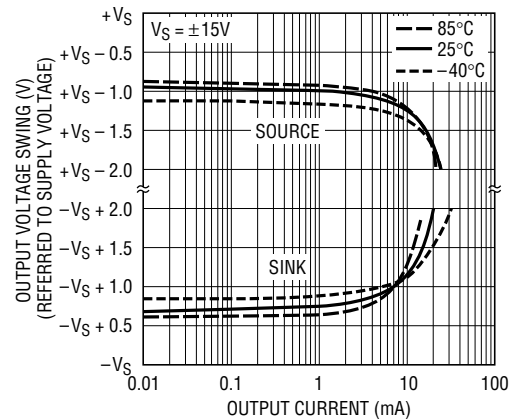

1167 G39

## BLOCK DIAGRAM

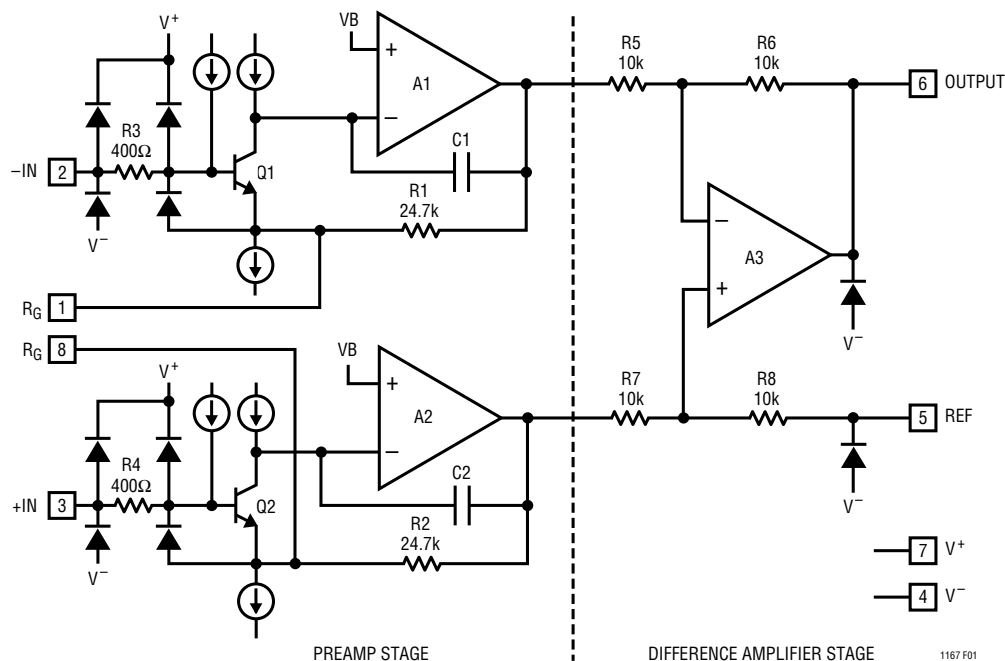

Figure 1. Block Diagram

## THEORY OF OPERATION

The LT1167 is a modified version of the three op amp instrumentation amplifier. Laser trimming and monolithic construction allow tight matching and tracking of circuit parameters over the specified temperature range. Refer to the block diagram (Figure 1) to understand the following circuit description. The collector currents in Q1 and Q2 are trimmed to minimize offset voltage drift, thus assuring a high level of performance. R1 and R2 are trimmed to an absolute value of 24.7k to assure that the gain can be set accurately (0.05% at  $G = 100$ ) with only one external resistor  $R_G$ . The value of  $R_G$  in parallel with R1 (R2) determines the transconductance of the preamp stage. As  $R_G$  is reduced for larger programmed gains, the transconductance of the input preamp stage increases to that of the input transistors Q1 and Q2. This increases the open-loop gain when the programmed gain is increased, reducing the input referred gain related errors and noise. The input voltage noise at gains greater than 50 is determined only by Q1 and Q2. At lower gains the noise of the difference amplifier and preamp gain setting resistors increase the noise. The gain bandwidth product is determined by C1, C2 and the preamp transconductance which increases

with programmed gain. Therefore, the bandwidth does not drop proportional to gain.

The input transistors Q1 and Q2 offer excellent matching, which is inherent in NPN bipolar transistors, as well as picoampere input bias current due to superbeta processing. The collector currents in Q1 and Q2 are held constant due to the feedback through the Q1-A1-R1 loop and Q2-A2-R2 loop which in turn impresses the differential input voltage across the external gain set resistor  $R_G$ . Since the current that flows through  $R_G$  also flows through R1 and R2, the ratios provide a gained-up differential voltage,  $G = (R1 + R2)/R_G$ , to the unity-gain difference amplifier A3. The common mode voltage is removed by A3, resulting in a single-ended output voltage referenced to the voltage on the REF pin. The resulting gain equation is:

$$V_{OUT} - V_{REF} = G(V_{IN}^+ - V_{IN}^-)$$

where:

$$G = (49.4\text{k}\Omega/R_G) + 1$$

solving for the gain set resistor gives:

$$R_G = 49.4\text{k}\Omega/(G - 1)$$



## THEORY OF OPERATION

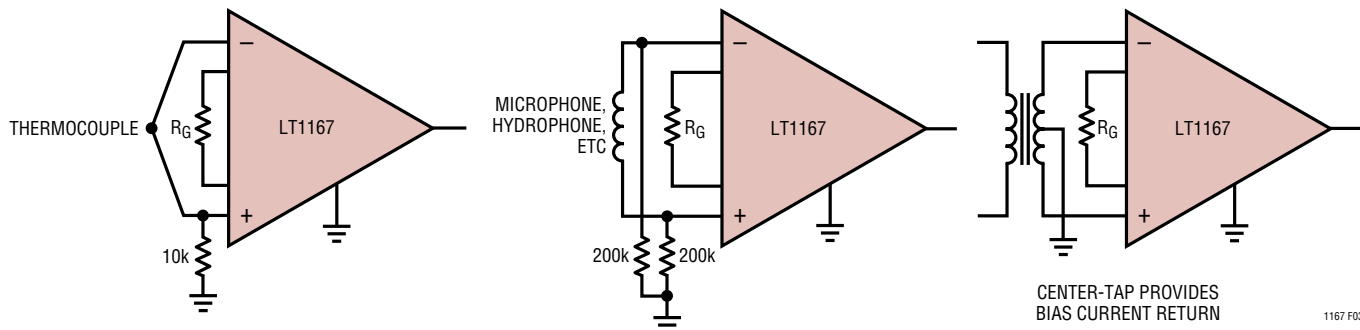

Figure 3. Providing an Input Common Mode Current Path

## APPLICATIONS INFORMATION

The LT1167 is a low power precision instrumentation amplifier that requires only one external resistor to accurately set the gain anywhere from 1 to 1000. The output can handle capacitive loads up to 1000pF in any gain configuration and the inputs are protected against ESD strikes up to 13kV (human body).

### Input Protection

The LT1167 can safely handle up to  $\pm 20\text{mA}$  of input current in an overload condition. Adding an external 5k input resistor in series with each input allows DC input fault voltages up to  $\pm 100\text{V}$  and improves the ESD immunity to 8kV (contact) and 15kV (air discharge), which is the IEC 1000-4-2 level 4 specification. If lower value input resistors are needed, a clamp diode from the positive supply to each input will maintain the IEC 1000-4-2 specification to level 4 for both air and contact discharge.

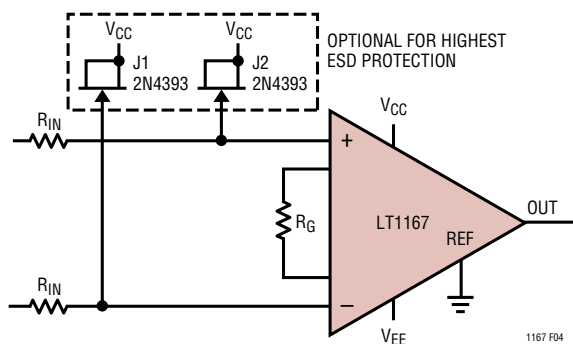

Figure 4. Input Protection

A 2N4393 drain/source to gate is a good low leakage diode for use with 1k resistors, see Figure 4. The input resistors should be carbon and not metal film or carbon film.

### RFI Reduction

In many industrial and data acquisition applications, instrumentation amplifiers are used to accurately amplify small signals in the presence of large common mode voltages or high levels of noise. Typically, the sources of these very small signals (on the order of microvolts or millivolts) are sensors that can be a significant distance from the signal conditioning circuit. Although these sensors may be connected to signal conditioning circuitry, using shielded or unshielded twisted-pair cabling, the cabling may act as antennae, conveying very high frequency interference directly into the input stage of the LT1167.

The amplitude and frequency of the interference can have an adverse effect on an instrumentation amplifier's input stage by causing an unwanted DC shift in the amplifier's input offset voltage. This well known effect is called RFI rectification and is produced when out-of-band interference is coupled (inductively, capacitively or via radiation) and rectified by the instrumentation amplifier's input transistors. These transistors act as high frequency signal detectors, in the same way diodes were used as RF envelope detectors in early radio designs. Regardless of the type of interference or the method by which it is coupled into the circuit, an out-of-band error signal appears in series with the instrumentation amplifier's inputs.

## APPLICATIONS INFORMATION

To significantly reduce the effect of these out-of-band signals on the input offset voltage of instrumentation amplifiers, simple lowpass filters can be used at the inputs. This filter should be located very close to the input pins of the circuit. An effective filter configuration is illustrated in Figure 5, where three capacitors have been added to the inputs of the LT1167. Capacitors  $C_{XCM1}$  and  $C_{XCM2}$  form lowpass filters with the external series resistors  $R_{S1,2}$  to any out-of-band signal appearing on each of the input traces. Capacitor  $C_{XD}$  forms a filter to reduce any unwanted signal that would appear across the input traces. An added benefit to using  $C_{XD}$  is that the circuit's AC common mode rejection is not degraded due to common mode capacitive imbalance. The differential mode and common mode time constants associated with the capacitors are:

$$t_{DM(LPF)} = (2)(R_S)(C_{XD})$$

$$t_{CM(LPF)} = (R_{S1,2})(C_{XCM1,2})$$

Setting the time constants requires a knowledge of the frequency, or frequencies of the interference. Once this frequency is known, the common mode time constants can be set followed by the differential mode time constant. To avoid any possibility of inadvertently affecting the

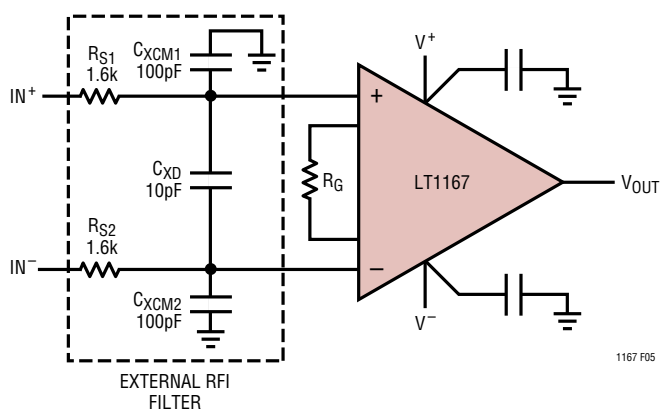

**Figure 5. Adding a Simple RC Filter at the Inputs to an Instrumentation Amplifier is Effective in Reducing Rectification of High Frequency Out-of-Band Signals**

signal to be processed, set the common mode time constant an order of magnitude (or more) larger than the differential mode time constant. To avoid any possibility of common mode to differential mode signal conversion, match the common mode time constants to 1% or better. If the sensor is an RTD or a resistive strain gauge, then the series resistors  $R_{S1,2}$  can be omitted, if the sensor is in proximity to the instrumentation amplifier.

### “Roll Your Own”—Discrete vs Monolithic LT1167 Error Budget Analysis

The LT1167 offers performance superior to that of “roll your own” three op amp discrete designs. A typical application that amplifies and buffers a bridge transducer’s differential output is shown in Figure 6. The amplifier, with its gain set to 100, amplifies a differential, full-scale output voltage of 20mV over the industrial range. To make the comparison challenging, the low cost version of the LT1167 will be compared to a discrete instrumentation amp made with the A grade of one of the best precision quad op amps, the LT1114A. The LT1167C outperforms the discrete amplifier that has lower  $V_{OS}$ , lower  $I_B$  and comparable  $V_{OS}$  drift. The error budget comparison in Table 1 shows how various errors are calculated and how each error affects the total error budget. The table shows the greatest differences between the discrete solution and the LT1167 are input offset voltage and CMRR. Note that for the discrete solution, the noise voltage specification is multiplied by  $\sqrt{2}$  which is the RMS sum of the uncorelated noise of the two input amplifiers. Each of the amplifier errors is referenced to a full-scale bridge differential voltage of 20mV. The common mode range of the bridge is 5V. The LT1114 data sheet provides offset voltage, offset voltage drift and offset current specifications for the matched op amp pairs used in the error-budget table. Even with an excellent matching op amp like the LT1114, the discrete solution’s total error is significantly higher than the LT1167’s total error. The LT1167 has additional advantages over the discrete design, including lower component cost and smaller size.

## APPLICATIONS INFORMATION

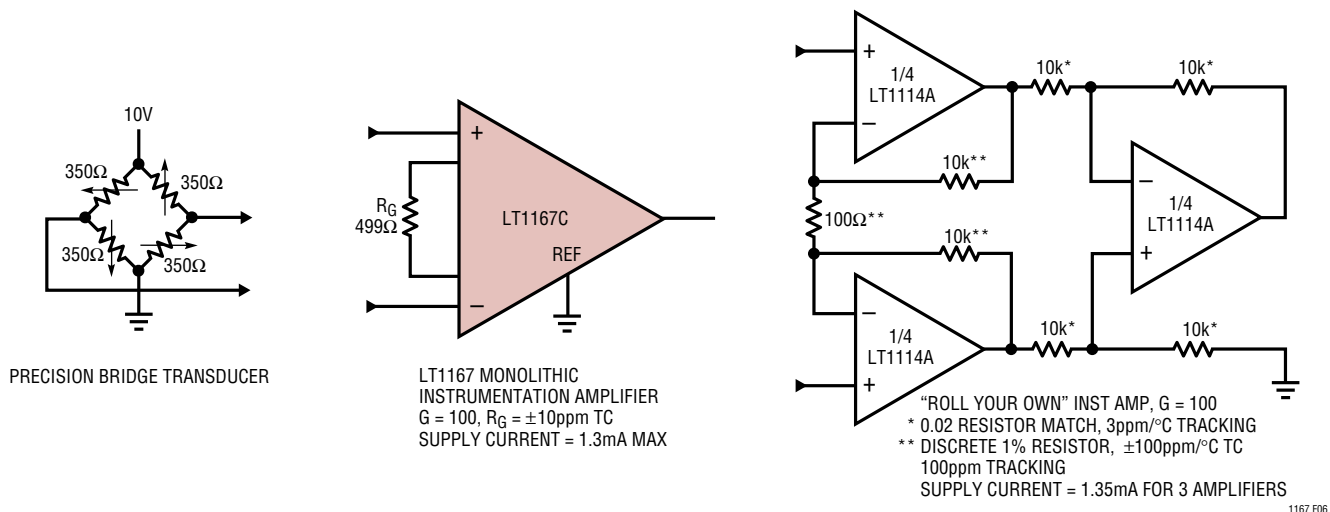

Figure 6. "Roll Your Own" vs LT1167

Table 1. "Roll Your Own" vs LT1167 Error Budget

ERROR SOURCE	LT1167C CIRCUIT CALCULATION	"ROLL YOUR OWN" CIRCUIT CALCULATION	ERROR, ppm OF FULL SCALE	
			LT1167C	"ROLL YOUR OWN"
<b>Absolute Accuracy at <math>T_A = 25^\circ\text{C}</math></b>				
Input Offset Voltage, $\mu\text{V}$	$60\mu\text{V}/20\text{mV}$	$100\mu\text{V}/20\text{mV}$	3000	5000
Output Offset Voltage, $\mu\text{V}$	$(300\mu\text{V}/100)/20\text{mV}$	$[(60\mu\text{V})(2)/100]/20\text{mV}$	150	60
Input Offset Current, nA	$[(450\text{pA})(350/2)\Omega]/20\text{mV}$	$[(450\text{pA})(350\Omega)/2]/20\text{mV}$	4	4
CMR, dB	$110\text{dB} \rightarrow [(3.16\text{ppm})(5\text{V})]/20\text{mV}$	$[(0.02\% \text{ Match})(5\text{V})]/20\text{mV}$	790	500
<b>Total Absolute Error</b>			<b>3944</b>	<b>5564</b>
<b>Drift to <math>85^\circ\text{C}</math></b>				
Gain Drift, ppm/°C	$(50\text{ppm} + 10\text{ppm})(60^\circ\text{C})$	$(100\text{ppm/°C Track})(60^\circ\text{C})$	3600	6000
Input Offset Voltage Drift, $\mu\text{V/°C}$	$[(0.4\mu\text{V/°C})(60^\circ\text{C})]/20\text{mV}$	$[(1.6\mu\text{V/°C})(60^\circ\text{C})]/20\text{mV}$	1200	4800
Output Offset Voltage Drift, $\mu\text{V/°C}$	$[6\mu\text{V/°C}(60^\circ\text{C})]/100/20\text{mV}$	$[(1.1\mu\text{V/°C})(2)(60^\circ\text{C})]/100/20\text{mV}$	180	66
<b>Total Drift Error</b>			<b>4980</b>	<b>10866</b>
<b>Resolution</b>				
Gain Nonlinearity, ppm of Full Scale	15ppm	10ppm	15	10
Typ 0.1Hz to 10Hz Voltage Noise, $\mu\text{V}_{\text{P-P}}$	$0.28\mu\text{V}_{\text{P-P}}/20\text{mV}$	$(0.3\mu\text{V}_{\text{P-P}})(\sqrt{2})/20\text{mV}$	14	21
<b>Total Resolution Error</b>			<b>29</b>	<b>31</b>
<b>Grand Total Error</b>			<b>8953</b>	<b>16461</b>

$G = 100$ ,  $V_S = \pm 15\text{V}$

All errors are min/max and referred to input.

### Current Source

Figure 7 shows a simple, accurate, low power programmable current source. The differential voltage across Pins 2 and 3 is mirrored across  $R_G$ . The voltage across  $R_G$  is amplified and applied across  $R_X$ , defining the output

current. The  $50\mu\text{A}$  bias current flowing from Pin 5 is buffered by the LT1464 JFET operational amplifier. This has the effect of improving the resolution of the current source to 3pA, which is the maximum  $I_B$  of the LT1464A. Replacing  $R_G$  with a programmable resistor greatly increases the range of available output currents.

**APPLICATIONS INFORMATION**

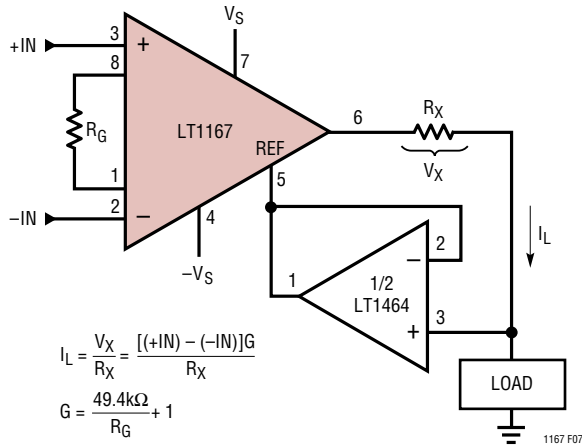

**Figure 7. Precision Voltage-to-Current Converter**

**Nerve Impulse Amplifier**

The LT1167's low current noise makes it ideal for high source impedance EMG monitors. Demonstrating the LT1167's ability to amplify low level signals, the circuit in Figure 8 takes advantage of the amplifier's high gain and low noise operation. This circuit amplifies the low level nerve impulse signals received from a patient at Pins 2 and 3. RG and the parallel combination of R3 and R4 set a gain of ten. The potential on LT1167's Pin 1 creates a ground for the common mode signal. C1 was chosen to maintain the stability of the patient ground. The LT1167's high CMRR ensures that the desired differential signal is amplified and unwanted common mode signals are attenuated. Since the DC portion of the signal is not

important, R6 and C2 make up a 0.3Hz highpass filter. The AC signal at LT1167's Pin 5 is amplified by a gain of 101 set by (R7/R8) + 1. The parallel combination of C3 and R7 form a lowpass filter that decreases this gain at frequencies above 1kHz. The ability to operate at ±3V on 0.9mA of supply current makes the LT1167 ideal for battery-powered applications. Total supply current for this application is 1.7mA. Proper safeguards, such as isolation, must be added to this circuit to protect the patient from possible harm.

**Low IB Favors High Impedance Bridges, Lowers Dissipation**

The LT1167's low supply current, low supply voltage operation and low input bias currents optimize it for battery-powered applications. Low overall power dissipation necessitates using higher impedance bridges. The single supply pressure monitor application (Figure 9) shows the LT1167 connected to the differential output of a 3.5k bridge. The bridge's impedance is almost an order of magnitude higher than that of the bridge used in the error-budget table. The picoampere input bias currents keep the error caused by offset current to a negligible level. The LT1112 level shifts the LT1167's reference pin and the ADC's analog ground pins above ground. The LT1167's and LT1112's combined power dissipation is still less than the bridge's. This circuit's total supply current is just 2.8mA.

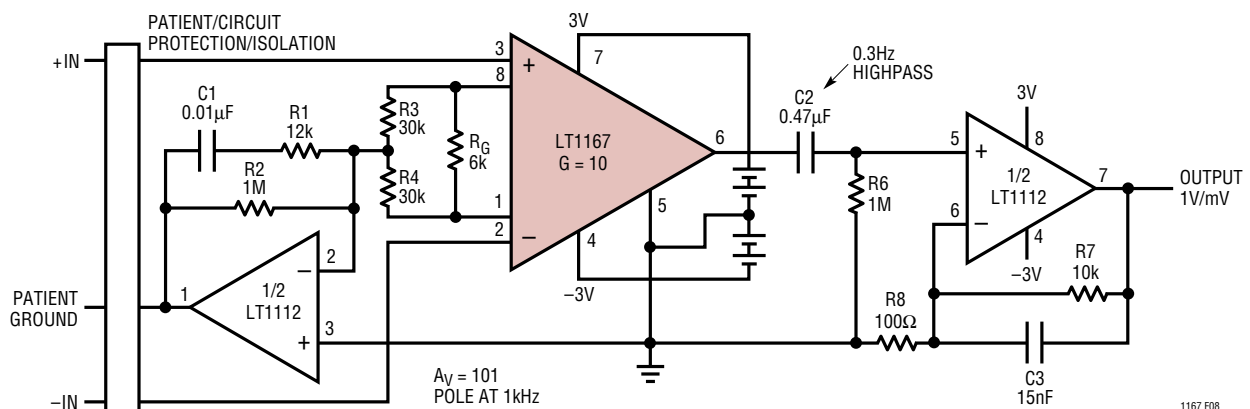

**Figure 8. Nerve Impulse Amplifier**

## APPLICATIONS INFORMATION

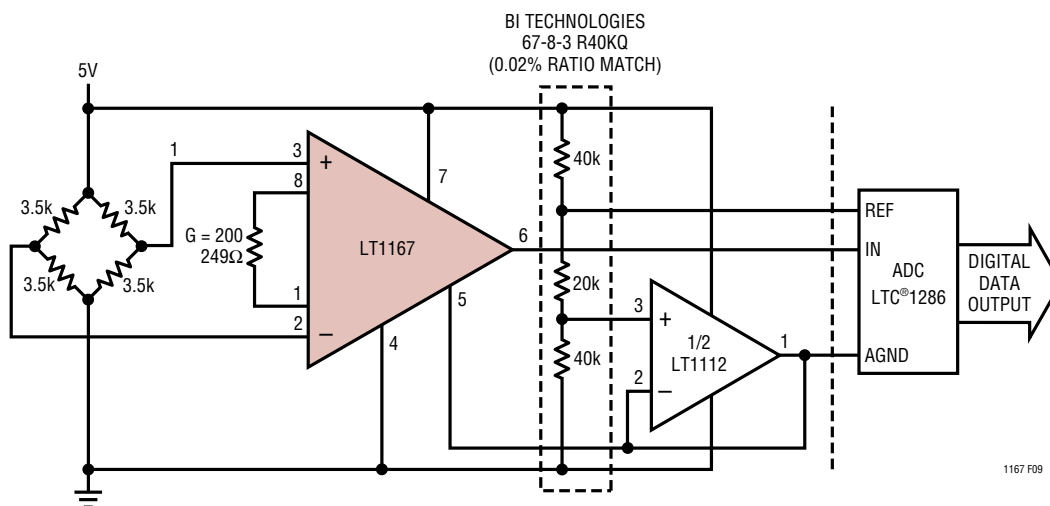
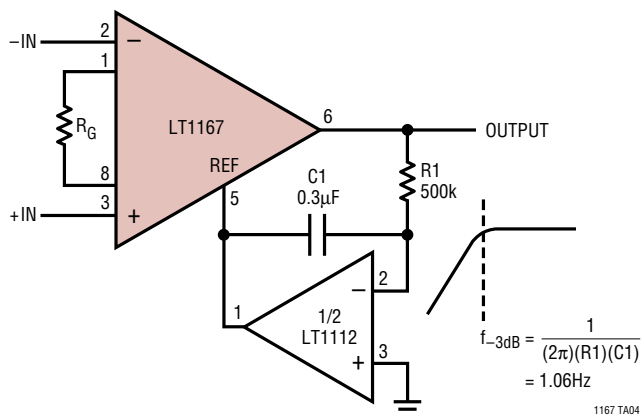

Figure 9. Single Supply Pressure Monitor

## TYPICAL APPLICATION

### AC Coupled Instrumentation Amplifier



LT1167

## PACKAGE DESCRIPTION

Dimensions in inches (millimeters) unless otherwise noted.

### N8 Package 8-Lead PDIP (Narrow 0.300) (LTC DWG # 05-08-1510)

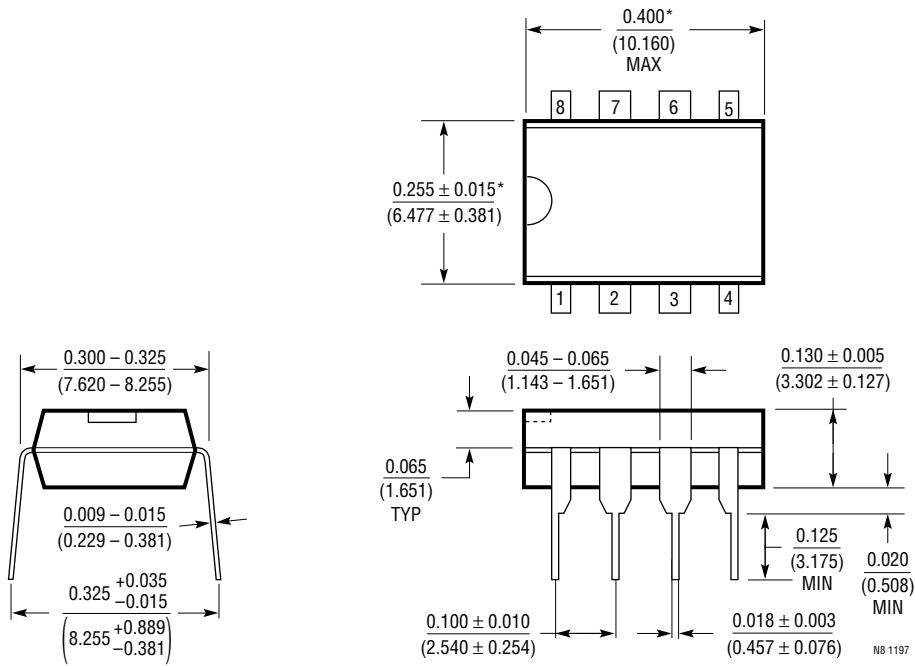

\*THESE DIMENSIONS DO NOT INCLUDE MOLD FLASH OR PROTRUSIONS.  
MOLD FLASH OR PROTRUSIONS SHALL NOT EXCEED 0.010 INCH (0.254mm)

N8 1197

**PACKAGE DESCRIPTION**    Dimensions in inches (millimeters) unless otherwise noted.

**S8 Package**  
**8-Lead Plastic Small Outline (Narrow 0.150)**  
 (LTC DWG # 05-08-1610)

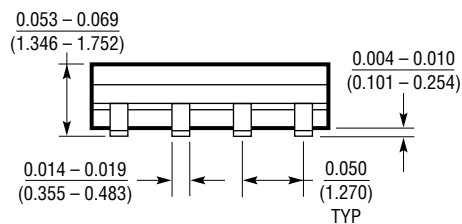
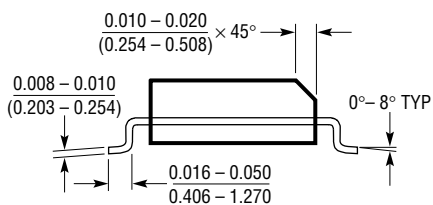
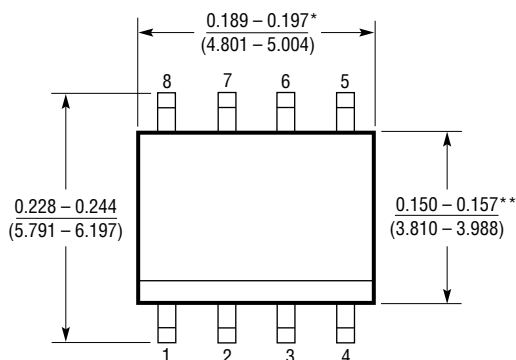

\* DIMENSION DOES NOT INCLUDE MOLD FLASH. MOLD FLASH SHALL NOT EXCEED 0.006" (0.152mm) PER SIDE

\*\* DIMENSION DOES NOT INCLUDE INTERLEAD FLASH. INTERLEAD FLASH SHALL NOT EXCEED 0.010" (0.254mm) PER SIDE

S08 0996

# LT1167

## TYPICAL APPLICATION

### 4-Digit Pressure Sensor

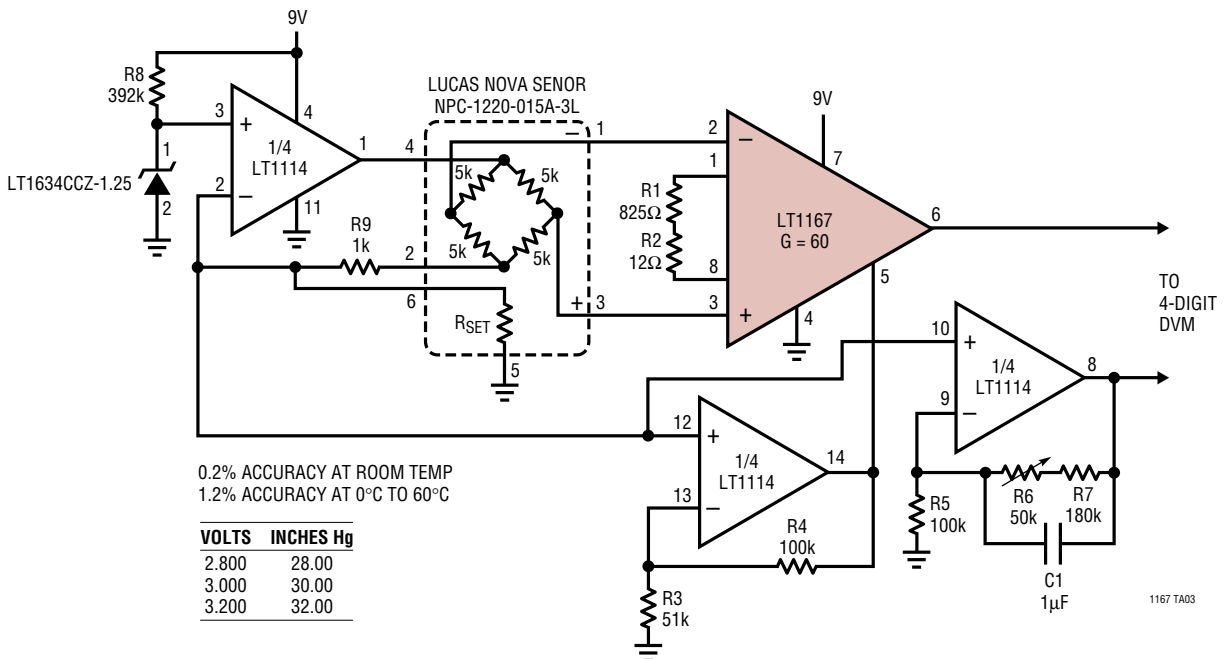

## RELATED PARTS

PART NUMBER	DESCRIPTION	COMMENTS
LTC1100	Precision Chopper-Stabilized Instrumentation Amplifier	Best DC Accuracy
LT1101	Precision, Micropower, Single Supply Instrumentation Amplifier	Fixed Gain of 10 or 100, $I_S < 105\mu A$
LT1102	High Speed, JFET Instrumentation Amplifier	Fixed Gain of 10 or 100, $30V/\mu s$ Slew Rate
LTC <sup>®</sup> 1418	14-Bit, Low Power, 200ksps ADC with Serial and Parallel I/O	Single Supply 5V or $\pm 5V$ Operation, $\pm 1.5$ LSB INL and $\pm 1$ LSB DNL Max
LT1460	Precision Series Reference	Micropower; 2.5V, 5V, 10V Versions; High Precision
LT1468	16-Bit Accurate Op Amp, Low Noise Fast Settling	16-Bit Accuracy at Low and High Frequencies, 90MHz GBW, $22V/\mu s$ , 900ns Settling
LTC1562	Active RC Filter	Lowpass, Bandpass, Highpass Responses; Low Noise, Low Distortion, Four 2nd Order Filter Sections
LTC1605	16-Bit, 100ksps, Sampling ADC	Single 5V Supply, Bipolar Input Range: $\pm 10V$ , Power Dissipation: 55mW Typ