



CYPRESS

**CY7C138AV/144AV/006AV**  
**CY7C139AV/145AV/016AV**  
**CY7C007AV/017AV**

**3.3V 4K/8K/16K/32K x 8/9**  
**Dual-Port Static RAM**

**Features**

- True Dual-Ported memory cells which allow simultaneous access of the same memory location
- 4K/8K/16K/32K x 8 organizations (CY7C0138AV/144AV/006AV/007AV)
- 4K/8K/16K/32K x 9 organizations (CY7C0139AV/145AV/016AV/017AV)
- 0.35-micron CMOS for optimum speed/power
- High-speed access: 20/25 ns
- Low operating power
  - Active:  $I_{CC} = 115 \text{ mA}$  (typical)
  - Standby:  $I_{SB3} = 10 \mu\text{A}$  (typical)
- Fully asynchronous operation
- Automatic power-down
- Expandable data bus to 16/18 bits or more using Master/Slave chip select when using more than one device
- On-chip arbitration logic
- Semaphores included to permit software handshaking between ports
- INT flag for port-to-port communication
- Pin select for Master or Slave
- Commercial and Industrial Temperature Ranges
- Available in 68-pin PLCC (all) and 64-pin TQFP (7C006AV & 7C144AV)
- Pin-compatible and functionally equivalent to IDT70V05, 70V06, and 70V07.

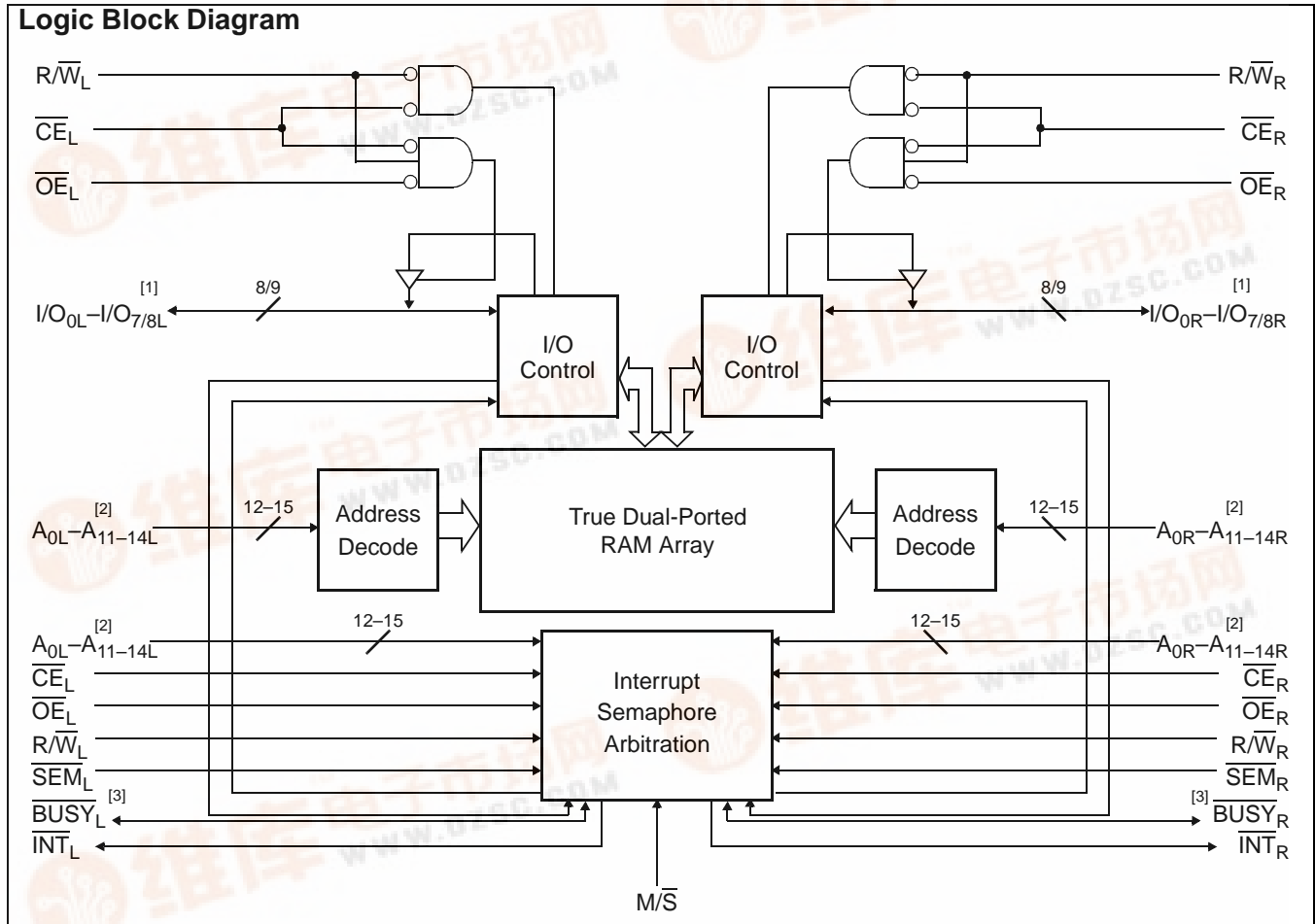

- Notes:**
1. I/O<sub>0</sub>–I/O<sub>7</sub> for x8 devices; I/O<sub>0</sub>–I/O<sub>8</sub> for x9 devices.
  2. A<sub>0</sub>–A<sub>11</sub> for 4K devices; A<sub>0</sub>–A<sub>12</sub> for 8K devices; A<sub>0</sub>–A<sub>13</sub> for 16K devices; A<sub>0</sub>–A<sub>14</sub> for 32K devices;
  3. BUSY is an output in master mode and an input in slave mode.





**CY7C138AV/144AV/006AV**  
**CY7C139AV/145AV/016AV**  
**CY7C007AV/017AV**

**Functional Description**

The CY7C138AV/144AV/006AV/007AV and CY7C139AV/145AV/016AV/017AV are low-power CMOS 4K, 8K, 16K, and 32K x8/9 dual-port static RAMs. Various arbitration schemes are included on the devices to handle situations when multiple processors access the same piece of data. Two ports are provided, permitting independent, asynchronous access for reads and writes to any location in memory. The devices can be utilized as standalone 8/9-bit dual-port static RAMs or multiple devices can be combined in order to function as a 16/18-bit or wider master/slave dual-port static RAM. An M/S pin is provided for implementing 16/18-bit or wider memory applications without the need for separate master and slave devices or additional discrete logic. Application areas include interpro-

cessor/multiprocessor designs, communications status buffering, and dual-port video/graphics memory.

Each port has independent control pins: Chip Enable ( $\overline{CE}$ ), Read or Write Enable (R/W), and Output Enable ( $\overline{OE}$ ). Two flags are provided on each port (BUSY and INT). BUSY signals that the port is trying to access the same location currently being accessed by the other port. The Interrupt flag ( $\overline{INT}$ ) permits communication between ports or systems by means of a mail box. The semaphores are used to pass a flag, or token, from one port to the other to indicate that a shared resource is in use. The semaphore logic is comprised of eight shared latches. Only one side can control the latch (semaphore) at any time. Control of a semaphore indicates that a shared resource is in use. An automatic power-down feature is controlled independently on each port by a Chip Select (CE) pin.

**Pin Configurations**

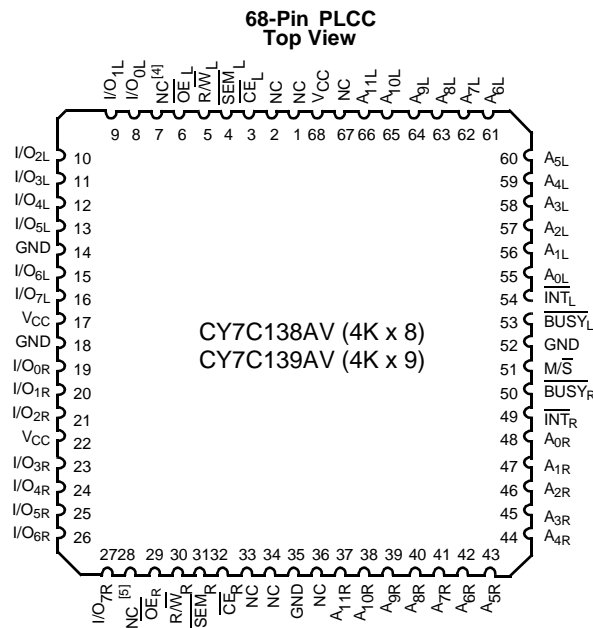

**Notes:**

- 4. I/O<sub>8L</sub> on the CY7C139AV.
- 5. I/O<sub>8R</sub> on the CY7C139AV.



**CY7C138AV/144AV/006AV**  
**CY7C139AV/145AV/016AV**  
**CY7C007AV/017AV**

**Pin Configurations** (continued)

**68-Pin PLCC**  
**Top View**

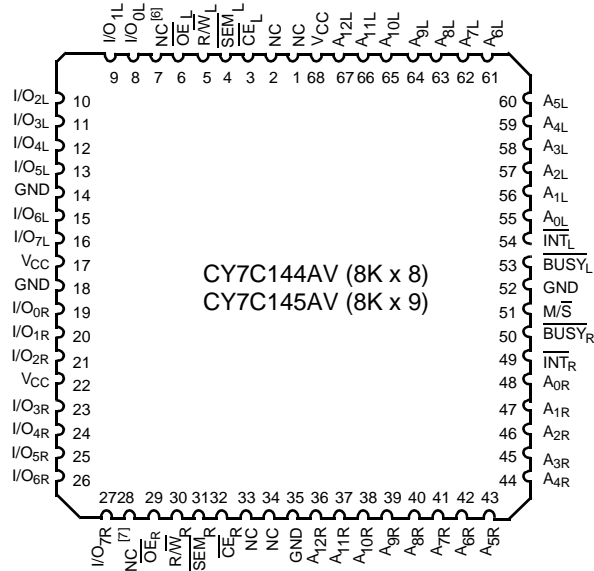

**64-Pin TQFP**  
**Top View**

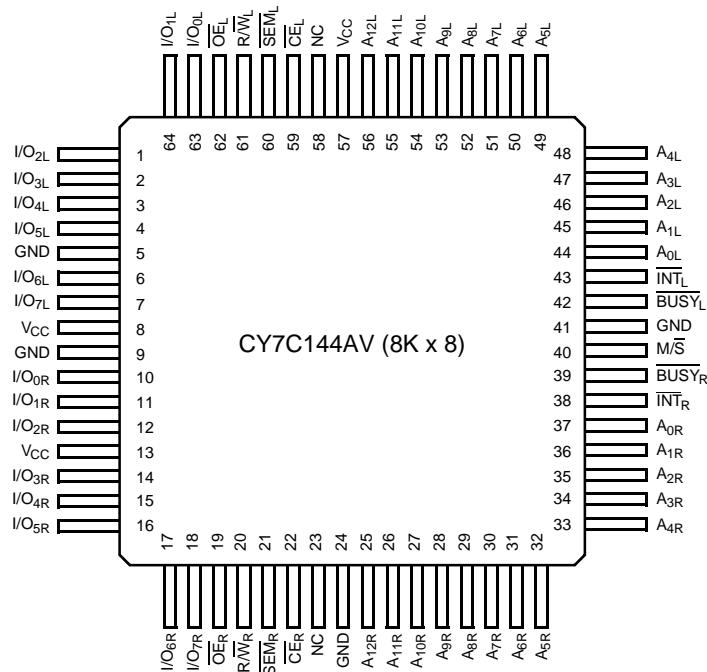

**Notes:**

- 6. I/O<sub>8L</sub> on the CY7C145AV.
- 7. I/O<sub>8R</sub> on the CY7C145AV.





**Selection Guide**

	CY7C138AV/144AV/006AV CY7C139AV/145AV/016AV CY7C007AV/017AV -20	CY7C138AV/144AV/006AV CY7C139AV/145AV/016AV CY7C007AV/017AV -25
Maximum Access Time (ns)	20	25
Typical Operating Current (mA)	120	115
Typical Standby Current for I <sub>SB1</sub> (mA) (Both Ports TTL level)	35	30
Typical Standby Current for I <sub>SB3</sub> (μA) (Both Ports CMOS level)	10 μA	10 μA

**Pin Definitions**

Left Port	Right Port	Description
CE <sub>L</sub>	CE <sub>R</sub>	Chip Enable
R/W <sub>L</sub>	R/W <sub>R</sub>	Read/Write Enable
OE <sub>L</sub>	OE <sub>R</sub>	Output Enable
A <sub>0L</sub> -A <sub>14L</sub>	A <sub>0R</sub> -A <sub>14R</sub>	Address (A <sub>0</sub> -A <sub>11</sub> for 4K devices; A <sub>0</sub> -A <sub>12</sub> for 8K devices; A <sub>0</sub> -A <sub>13</sub> for 16K devices; A <sub>0</sub> -A <sub>14</sub> for 32K)
I/O <sub>0L</sub> -I/O <sub>8L</sub>	I/O <sub>0R</sub> -I/O <sub>8R</sub>	Data Bus Input/Output (I/O <sub>0</sub> -I/O <sub>7</sub> for x8 devices and I/O <sub>0</sub> -I/O <sub>8</sub> for x9)
SEM <sub>L</sub>	SEM <sub>R</sub>	Semaphore Enable
INT <sub>L</sub>	INT <sub>R</sub>	Interrupt Flag
BUSY <sub>L</sub>	BUSY <sub>R</sub>	Busy Flag
M/S		Master or Slave Select
V <sub>CC</sub>		Power
GND		Ground
NC		No Connect

**Maximum Ratings**<sup>[10]</sup>

(Above which the useful life may be impaired. For user guidelines, not tested.)

Storage Temperature ..... -65°C to +150°C

Ambient Temperature with Power Applied..... -55°C to +125°C

Supply Voltage to Ground Potential ..... -0.5V to +4.6V

DC Voltage Applied to Outputs in High Z State ..... -0.5V to V<sub>CC</sub>+0.5V

DC Input Voltage<sup>[11]</sup> ..... -0.5V to V<sub>CC</sub>+0.5V

Output Current into Outputs (LOW)..... 20 mA  
 Static Discharge Voltage ..... >2001V  
 Latch-Up Current..... >200 mA

**Operating Range**

Range	Ambient Temperature	V <sub>CC</sub>
Commercial	0°C to +70°C	3.3V ± 300 mV
Industrial <sup>[12]</sup>	-40°C to +85°C	3.3V ± 300 mV

**Notes:**

- 10. The Voltage on any input or I/O pin can not exceed the power pin during power-up.
- 11. Pulse width < 20 ns.
- 12. Industrial parts are available in CY7C007AV and CY7C017AV only.



**Electrical Characteristics** Over the Operating Range

Parameter	Description	CY7C138AV/144AV/006AV CY7C139AV/145AV/016AV CY7C007AV/017AV						Unit
		-20			-25			
		Min.	Typ.	Max.	Min.	Typ.	Max.	
V <sub>OH</sub>	Output HIGH Voltage (V <sub>CC</sub> = 3.3V)	2.4			2.4			V
V <sub>OL</sub>	Output LOW Voltage			0.4			0.4	V
V <sub>IH</sub>	Input HIGH Voltage	2.0			2.0			V
V <sub>IL</sub>	Input LOW Voltage			0.8			0.8	V
I <sub>OZ</sub>	Output Leakage Current	-10		10	-10		10	μA
I <sub>CC</sub>	Operating Current (V <sub>CC</sub> = Max., I <sub>OUT</sub> = 0 mA) Outputs Disabled	Com'l.	120	175		115	165	mA
		Ind. <sup>[12]</sup>	140	195				mA
I <sub>SB1</sub>	Standby Current (Both Ports TTL Level) CE <sub>L</sub> & CE <sub>R</sub> ≥ V <sub>IH</sub> , f = f <sub>MAX</sub> <sup>[13]</sup>	Com'l.	35	45		30	40	mA
		Ind. <sup>[12]</sup>	45	55				mA
I <sub>SB2</sub>	Standby Current (One Port TTL Level) CE <sub>L</sub>   CE <sub>R</sub> ≥ V <sub>IH</sub> , f = f <sub>MAX</sub> <sup>[13]</sup>	Com'l.	75	110		65	95	mA
		Ind. <sup>[12]</sup>	85	130				mA
I <sub>SB3</sub>	Standby Current (Both Ports CMOS Level) CE <sub>L</sub> & CE <sub>R</sub> ≥ V <sub>CC</sub> - 0.2V, f = 0 <sup>[13]</sup>	Com'l.	10	500		10	500	μA
		Ind. <sup>[12]</sup>	10	500				μA
I <sub>SB4</sub>	Standby Current (One Port CMOS Level) CE <sub>L</sub>   CE <sub>R</sub> ≥ V <sub>IH</sub> , f = f <sub>MAX</sub> <sup>[13]</sup>	Com'l.	70	95		60	80	mA
		Ind. <sup>[12]</sup>	80	105				mA

**Capacitance**<sup>[14]</sup>

Parameter	Description	Test Conditions	Max.	Unit
C <sub>IN</sub>	Input Capacitance	T <sub>A</sub> = 25°C, f = 1 MHz, V <sub>CC</sub> = 3.3V	10	pF
C <sub>OUT</sub>	Output Capacitance		10	pF

**AC Test Loads and Waveforms**

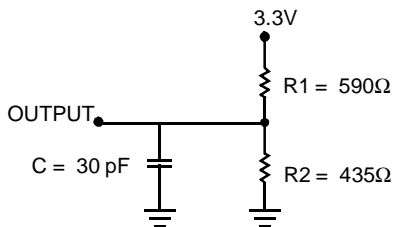

(a) Normal Load (Load 1)

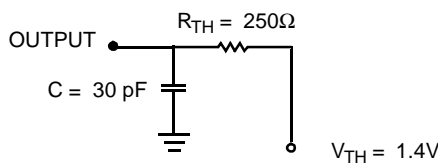

(b) Thévenin Equivalent (Load 1)

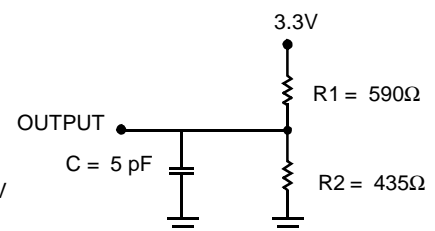

(c) Three-State Delay (Load 2)  
(Used for t<sub>LZ</sub>, t<sub>HZ</sub>, t<sub>HZWE</sub> & t<sub>LZWE</sub> including scope and jig)

ALL INPUT PULSES

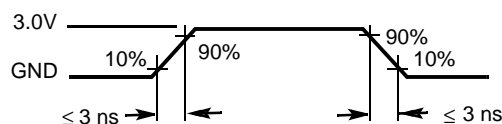

**Notes:**

- f<sub>MAX</sub> = 1/t<sub>RC</sub>. All inputs cycling at f = 1/t<sub>RC</sub> (except output enable). f = 0 means no address or control lines change. This applies only to inputs at CMOS level standby I<sub>SB3</sub>.
- Tested initially and after any design or process changes that may affect these parameters.



Switching Characteristics Over the Operating Range<sup>[15]</sup>

Parameter	Description	CY7C138AV/144AV/006AV CY7C139AV/145AV/016AV CY7C007AV/017AV				Unit
		-20		-25		
		Min.	Max.	Min.	Max.	
<b>READ CYCLE</b>						
t <sub>RC</sub>	Read Cycle Time	20		25		ns
t <sub>AA</sub>	Address to Data Valid		20		25	ns
t <sub>OHA</sub>	Output Hold From Address Change	3		3		ns
t <sub>ACE</sub> <sup>[16]</sup>	$\overline{CE}$ LOW to Data Valid		20		25	ns
t <sub>DOE</sub>	$\overline{OE}$ LOW to Data Valid		12		13	ns
t <sub>LZOE</sub> <sup>[17, 18, 19]</sup>	$\overline{OE}$ Low to Low Z	3		3		ns
t <sub>HZOE</sub> <sup>[17, 18, 19]</sup>	$\overline{OE}$ HIGH to High Z		12		15	ns
t <sub>LZCE</sub> <sup>[17, 18, 19]</sup>	$\overline{CE}$ LOW to Low Z	3		3		ns
t <sub>HZCE</sub> <sup>[17, 18, 19]</sup>	$\overline{CE}$ HIGH to High Z		12		15	ns
t <sub>PU</sub> <sup>[19]</sup>	$\overline{CE}$ LOW to Power-Up	0		0		ns
t <sub>PD</sub> <sup>[19]</sup>	$\overline{CE}$ HIGH to Power-Down		20		25	ns
<b>WRITE CYCLE</b>						
t <sub>WC</sub>	Write Cycle Time	20		25		ns
t <sub>SCE</sub> <sup>[16]</sup>	$\overline{CE}$ LOW to Write End	16		20		ns
t <sub>AW</sub>	Address Valid to Write End	16		20		ns
t <sub>HA</sub>	Address Hold From Write End	0		0		ns
t <sub>SA</sub> <sup>[16]</sup>	Address Set-Up to Write Start	0		0		ns
t <sub>PWE</sub>	Write Pulse Width	16		20		ns
t <sub>SD</sub>	Data Set-Up to Write End	12		15		ns
t <sub>HD</sub>	Data Hold From Write End	0		0		ns
t <sub>HZWE</sub> <sup>[18, 19]</sup>	R/ $\overline{W}$ LOW to High Z		12		15	ns
t <sub>LZWE</sub> <sup>[18, 19]</sup>	R/ $\overline{W}$ HIGH to Low Z	3		3		ns
t <sub>WDD</sub> <sup>[20]</sup>	Write Pulse to Data Delay		40		50	ns
t <sub>DDD</sub> <sup>[20]</sup>	Write Data Valid to Read Data Valid		30		35	ns
<b>BUSY TIMING</b> <sup>[21]</sup>						
t <sub>BLA</sub>	$\overline{BUSY}$ LOW from Address Match		20		20	ns
t <sub>BHA</sub>	$\overline{BUSY}$ HIGH from Address Mismatch		20		20	ns
t <sub>BLC</sub>	$\overline{BUSY}$ LOW from $\overline{CE}$ LOW		20		20	ns
t <sub>BHC</sub>	$\overline{BUSY}$ HIGH from $\overline{CE}$ HIGH		16		17	ns
t <sub>PS</sub>	Port Set-Up for Priority	5		5		ns

Note:

15. Test conditions assume signal transition time of 3 ns or less, timing reference levels of 1.5V, input pulse levels of 0 to 3.0V, and output loading of the specified I<sub>O</sub>/O<sub>H</sub> and 30-pF load capacitance.
16. To access RAM,  $\overline{CE}$ =L,  $\overline{SEM}$ =H. To access semaphore,  $\overline{CE}$ =H and  $\overline{SEM}$ =L. Either condition must be valid for the entire t<sub>SCE</sub> time.
17. At any given temperature and voltage condition for any given device, t<sub>HZCE</sub> is less than t<sub>LZCE</sub> and t<sub>HZOE</sub> is less than t<sub>LZOE</sub>.
18. Test conditions used are Load 3.
19. This parameter is guaranteed but not tested. For information on port-to-port delay through RAM cells from writing port to reading port, refer to Read Timing with Busy waveform.
20. For information on port-to-port delay through RAM cells from writing port to reading port, refer to Read Timing with Busy waveform.
21. Test conditions used are Load 2.



**Switching Characteristics** Over the Operating Range<sup>[15]</sup> (continued)

Parameter	Description	CY7C138AV/144AV/006AV CY7C139AV/145AV/016AV CY7C007AV/017AV				Unit
		-20		-25		
		Min.	Max.	Min.	Max.	
t <sub>WB</sub>	R $\bar{W}$ HIGH after $\overline{BUSY}$ (Slave)	0		0		ns
t <sub>WH</sub>	R $\bar{W}$ HIGH after $\overline{BUSY}$ HIGH (Slave)	15		17		ns
t <sub>BDD</sub> <sup>[22]</sup>	$\overline{BUSY}$ HIGH to Data Valid		20		25	ns
<b>INTERRUPT TIMING<sup>[21]</sup></b>						
t <sub>INS</sub>	$\overline{INT}$ Set Time		20		20	ns
t <sub>INR</sub>	$\overline{INT}$ Reset Time		20		20	ns
<b>SEMAPHORE TIMING</b>						
t <sub>SOP</sub>	SEM Flag Update Pulse ( $\overline{OE}$ or $\overline{SEM}$ )	10		12		ns
t <sub>SWRD</sub>	SEM Flag Write to Read Time	5		5		ns
t <sub>SPS</sub>	SEM Flag Contention Window	5		5		ns
t <sub>SAA</sub>	SEM Address Access Time		20		25	ns

**Data Retention Mode**

The CY7C0138AV/144AV/006AV/007AV and CY7C139AV/145AV/016AV/017AV are designed with battery backup in mind. Data retention voltage and supply current are guaranteed over temperature. The following rules ensure data retention:

1. Chip enable ( $\overline{CE}$ ) must be held HIGH during data retention, within  $V_{CC}$  to  $V_{CC} - 0.2V$ .
2.  $\overline{CE}$  must be kept between  $V_{CC} - 0.2V$  and 70% of  $V_{CC}$  during the power-up and power-down transitions.
3. The RAM can begin operation  $>t_{RC}$  after  $V_{CC}$  reaches the minimum operating voltage (3.0 volts).

**Timing**

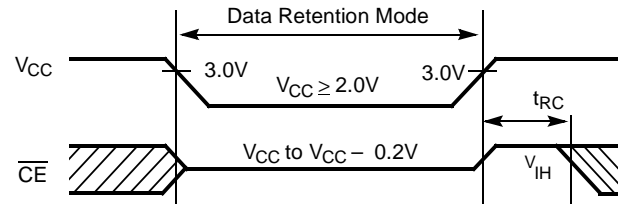

Parameter	Test Conditions <sup>[23]</sup>	Max.	Unit
ICC <sub>DR1</sub>	@ V <sub>CCDR</sub> = 2V	50	μA

**Notes:**

22. t<sub>BDD</sub> is a calculated parameter and is the greater of t<sub>WDD</sub>-t<sub>PWE</sub> (actual) or t<sub>D</sub>-t<sub>SD</sub> (actual).
23. CE = V<sub>CC</sub>, V<sub>in</sub> = GND to V<sub>CC</sub>, T<sub>A</sub> = 25°C. This parameter is guaranteed but not tested.

### Switching Waveforms

**Read Cycle No. 1 (Either Port Address Access)**<sup>[24, 25, 26]</sup>

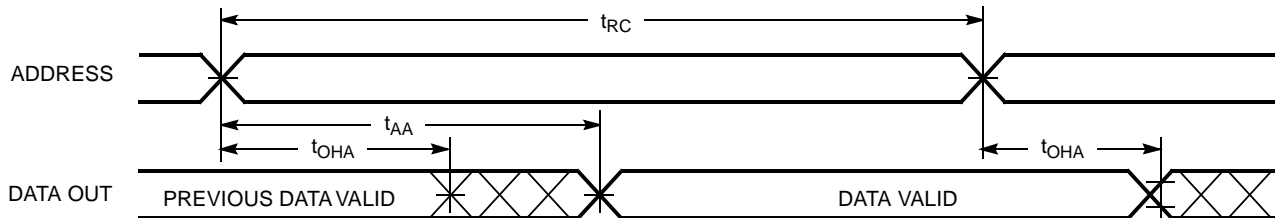

**Read Cycle No. 2 (Either Port  $\overline{CE}/\overline{OE}$  Access)**<sup>[24, 27, 28]</sup>

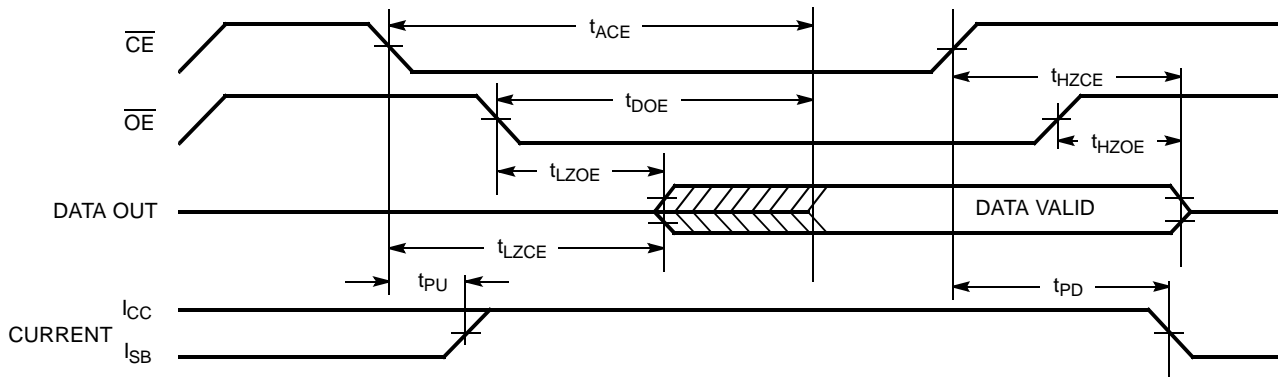

**Read Cycle No. 3 (Either Port)**<sup>[24, 26, 27, 28]</sup>

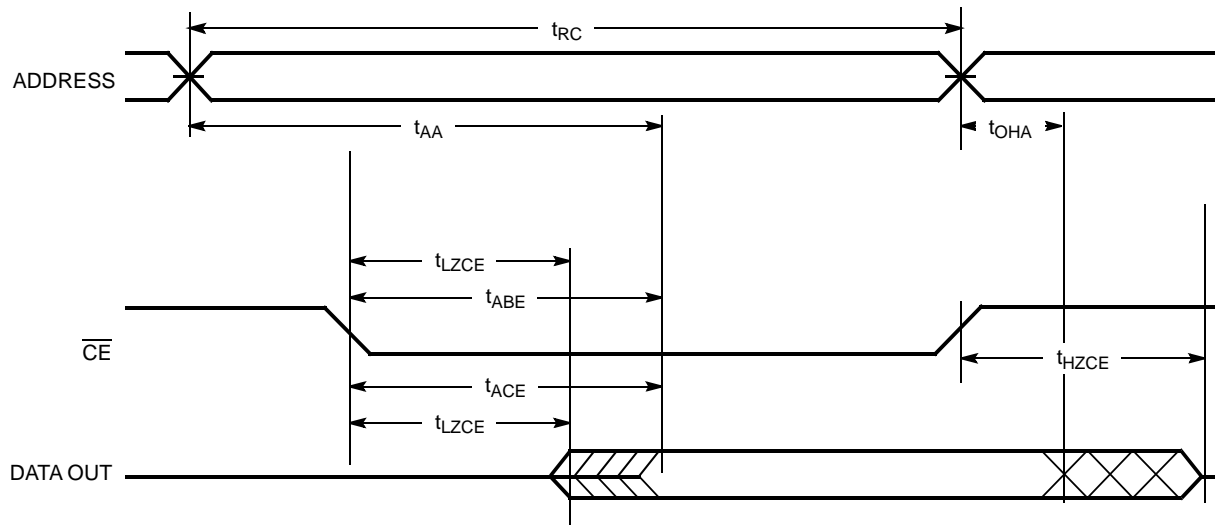

**Notes:**

24.  $R/\overline{W}$  is HIGH for read cycles.
25. Device is continuously selected  $\overline{CE} = V_{IL}$ . This waveform cannot be used for semaphore reads.
26.  $\overline{OE} = V_{IL}$ .
27. Address valid prior to or coincident with  $\overline{CE}$  transition LOW.
28. To access RAM,  $\overline{CE} = V_{IL}$ ,  $\overline{SEM} = V_{IH}$ . To access semaphore,  $\overline{CE} = V_{IH}$ ,  $\overline{SEM} = V_{IL}$ .



Switching Waveforms (continued)

Write Cycle No. 1: R/W Controlled Timing<sup>[29, 30, 31, 32]</sup>

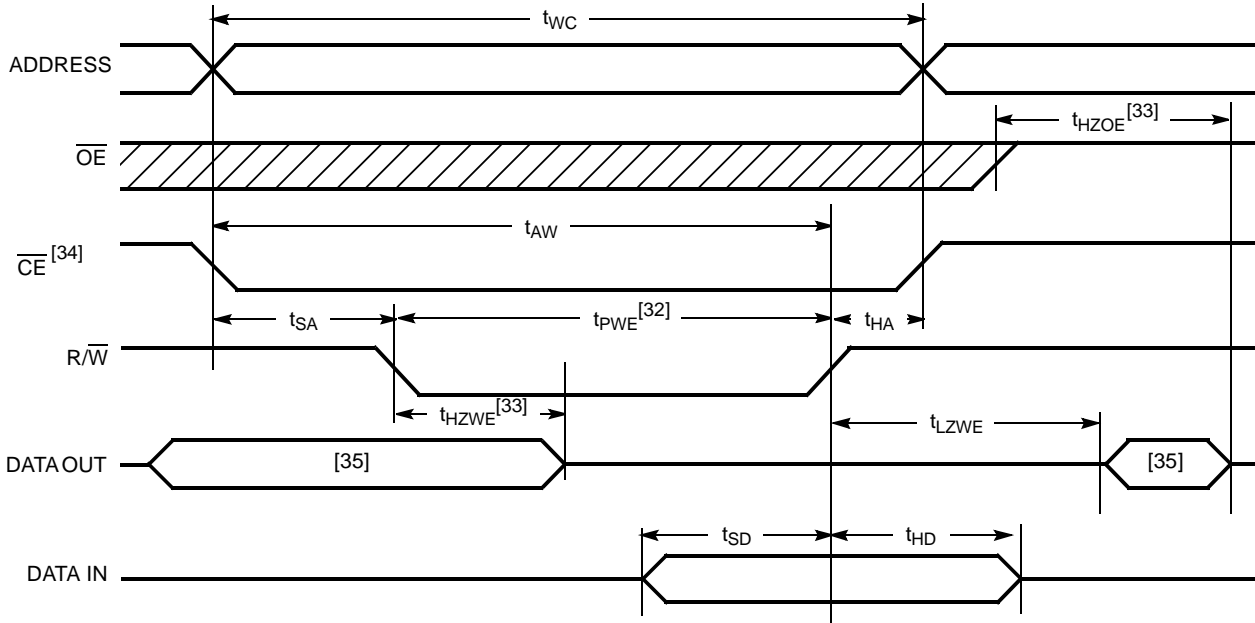

Write Cycle No. 2: CE Controlled Timing<sup>[29, 30, 31, 36]</sup>

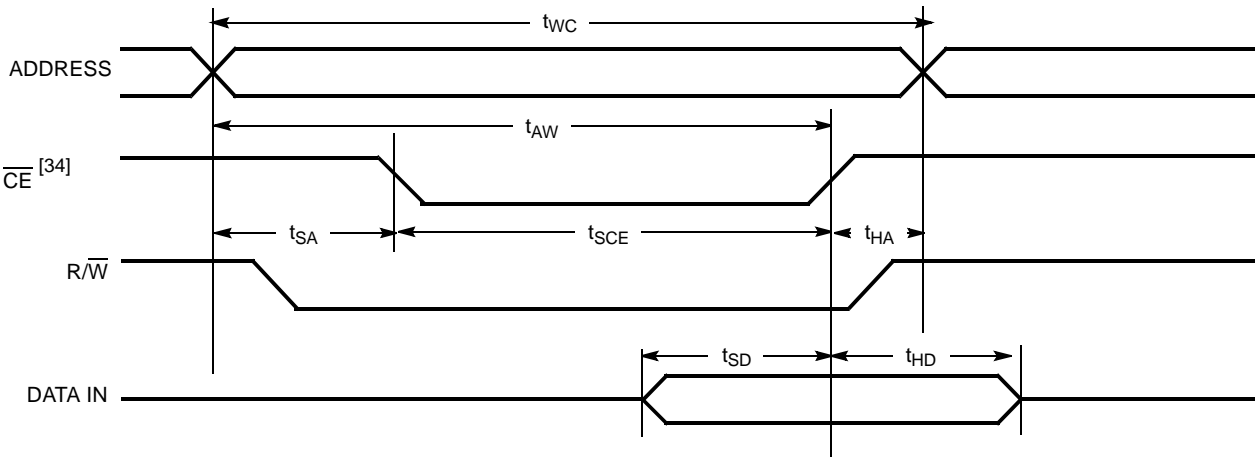

Notes:

- 29. R/W must be HIGH during all address transitions.
- 30. A write occurs during the overlap ( $t_{SCE}$  or  $t_{PWE}$ ) of a LOW CE or SEM.
- 31.  $t_{HA}$  is measured from the earlier of CE or R/W or (SEM or R/W) going HIGH at the end of write cycle.
- 32. If OE is LOW during a R/W controlled write cycle, the write pulse width must be the larger of  $t_{PWE}$  or ( $t_{HZWE} + t_{SD}$ ) to allow the I/O drivers to turn off and data to be placed on the bus for the required  $t_{SD}$ . If OE is HIGH during an R/W controlled write cycle, this requirement does not apply and the write pulse can be as short as the specified  $t_{PWE}$ .
- 33. Transition is measured  $\pm 500$  mV from steady state with a 5-pF load (including scope and jig). This parameter is sampled and not 100% tested.
- 34. To access RAM, CE =  $V_{IL}$ , SEM =  $V_{IH}$ .
- 35. During this period, the I/O pins are in the output state, and input signals must not be applied.
- 36. If the CE or SEM LOW transition occurs simultaneously with or after the R/W LOW transition, the outputs remain in the high-impedance state.

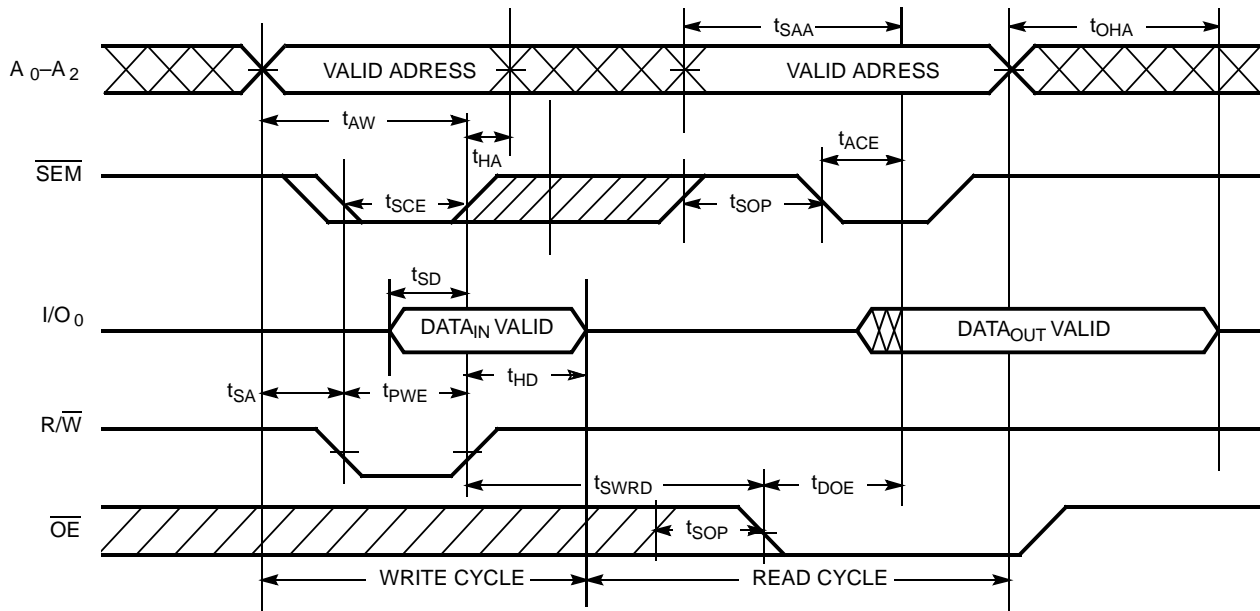
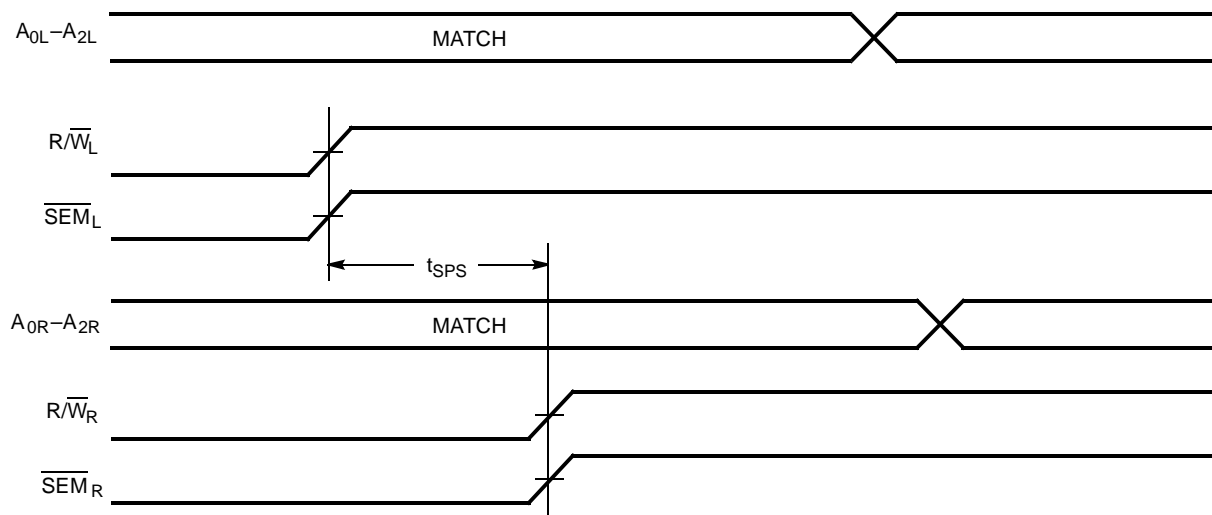
**Switching Waveforms (continued)**
**Semaphore Read After Write Timing, Either Side<sup>[37]</sup>**

**Timing Diagram of Semaphore Contention<sup>[38, 39, 40]</sup>**

**Notes:**

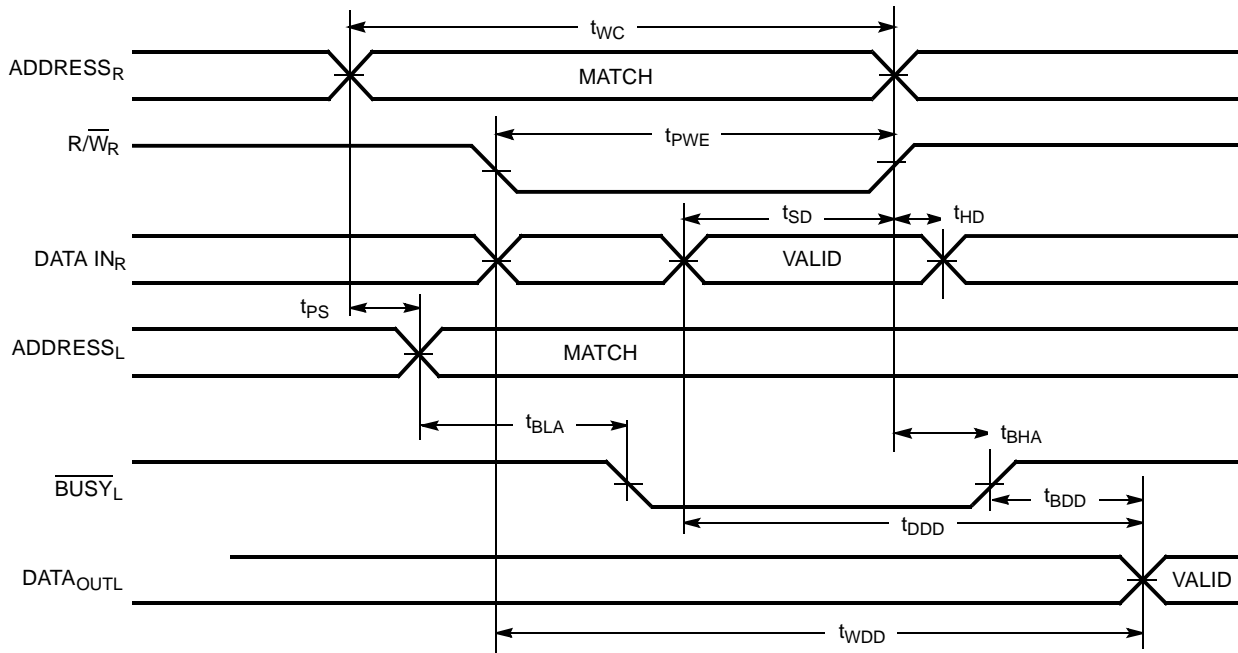
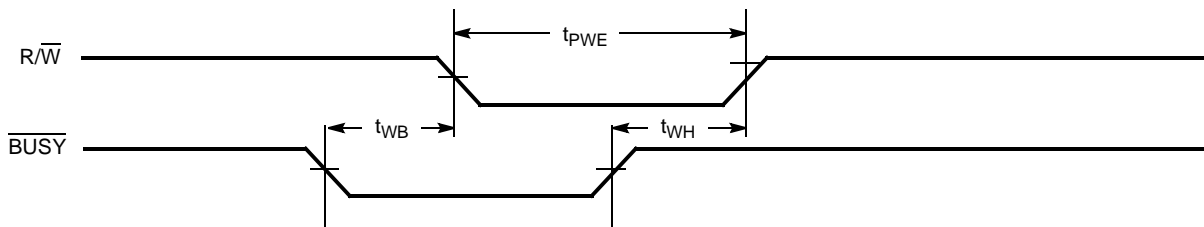
37.  $\overline{CE} = \text{HIGH}$  for the duration of the above timing (both write and read cycle).
38.  $I/O_{0R} = I/O_{0L} = \text{LOW}$  (request semaphore);  $CE_R = CE_L = \text{HIGH}$ .
39. Semaphores are reset (available to both ports) at cycle start.
40. If  $t_{SPS}$  is violated, the semaphore will definitely be obtained by one side or the other, but which side will get the semaphore is unpredictable.

**Switching Waveforms** (continued)

**Timing Diagram of Read with  $\overline{\text{BUSY}}$  ( $\text{M}/\overline{\text{S}}=\text{HIGH}$ )<sup>[41]</sup>**

**Write Timing with Busy Input ( $\text{M}/\overline{\text{S}}=\text{LOW}$ )**

**Note:**

 41.  $\overline{\text{CE}}_L = \overline{\text{CE}}_R = \text{LOW}$ .

Switching Waveforms (continued)

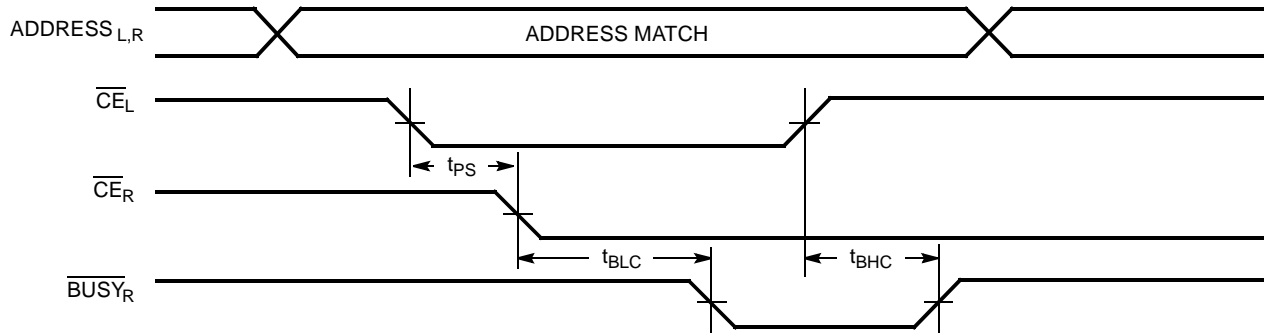
Busy Timing Diagram No. 1 ( $\overline{CE}$  Arbitration)<sup>[42]</sup>

$\overline{CE}_L$  Valid First:



$\overline{CE}_R$  Valid First:

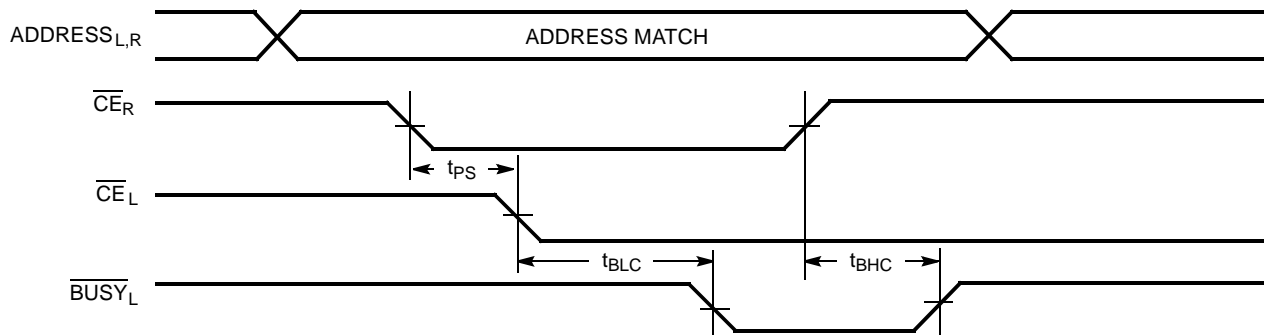

Busy Timing Diagram No. 2 (Address Arbitration)<sup>[42]</sup>

Left Address Valid First

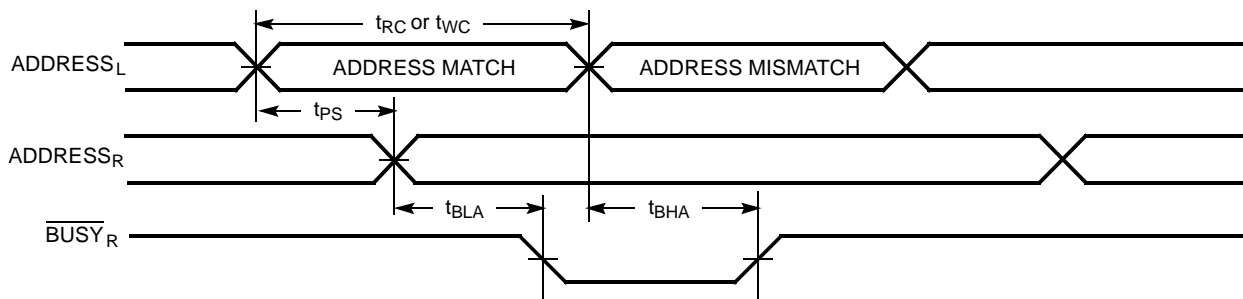

Right Address Valid First:

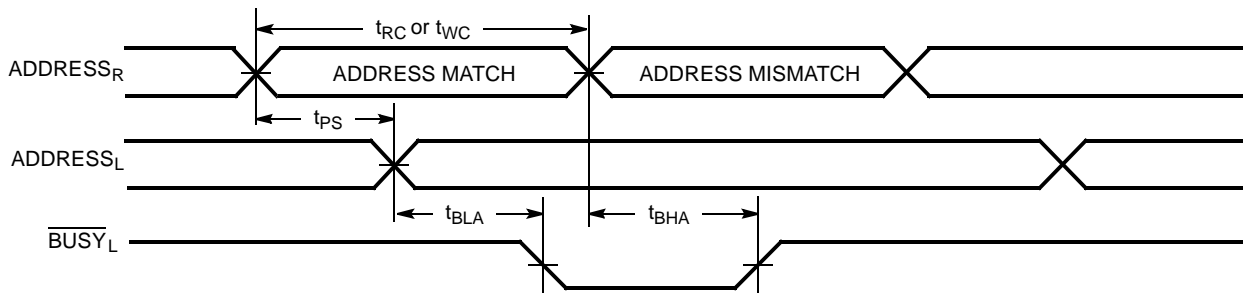

Note:

42. If  $t_{PS}$  is violated, the busy signal will be asserted on one side or the other, but there is no guarantee to which side  $\overline{BUSY}$  will be asserted.

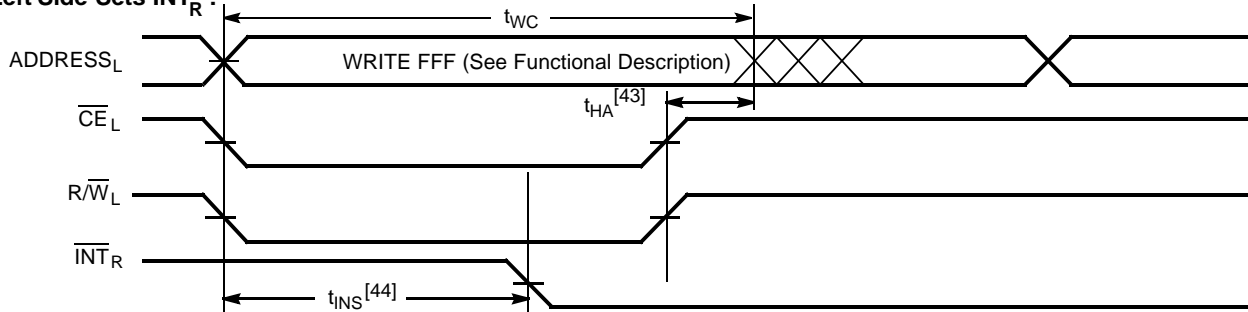
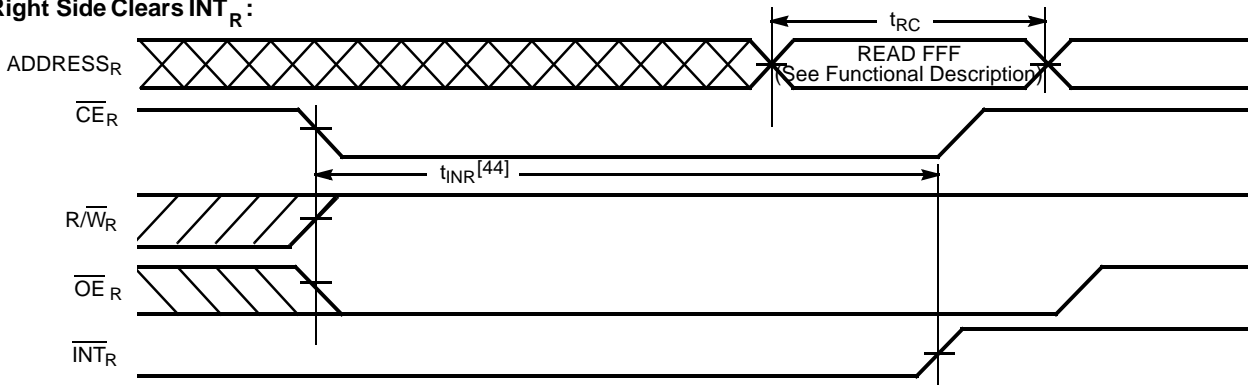
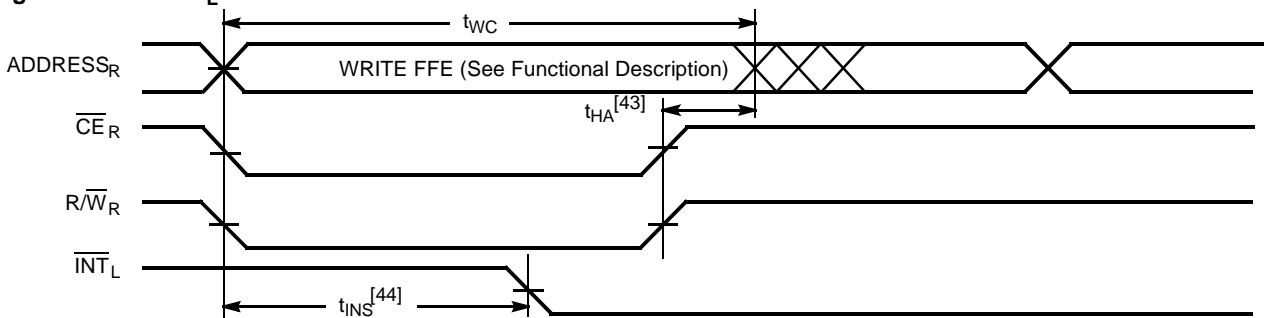
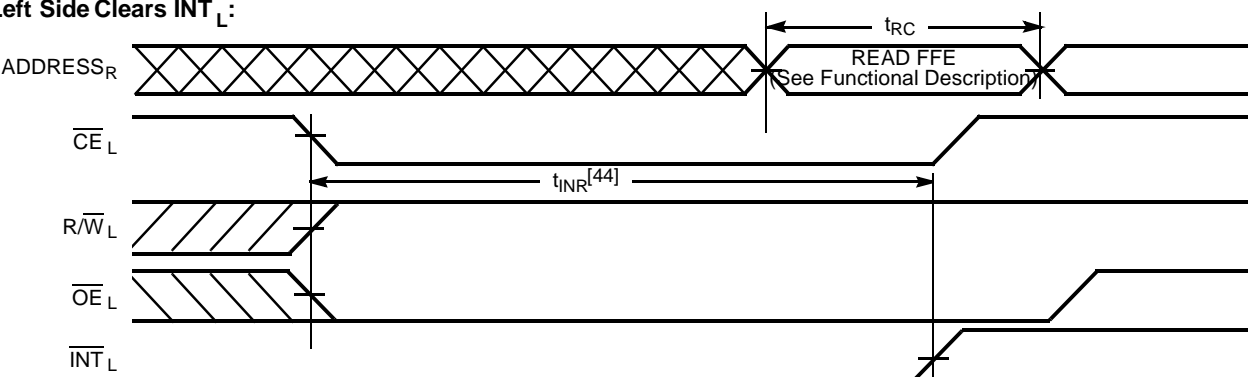
**Switching Waveforms (continued)**
**Interrupt Timing Diagrams**
**Left Side Sets  $\overline{\text{INT}}_R$  :**

**Right Side Clears  $\overline{\text{INT}}_R$  :**

**Right Side Sets  $\overline{\text{INT}}_L$  :**

**Left Side Clears  $\overline{\text{INT}}_L$  :**

**Notes:**

- 43.  $t_{HA}$  depends on which enable pin ( $\overline{\text{CE}}_L$  or  $\overline{\text{R}}\overline{\text{W}}_L$ ) is deasserted first.
- 44.  $t_{INS}$  or  $t_{INR}$  depends on which enable pin ( $\overline{\text{CE}}_L$  or  $\overline{\text{R}}\overline{\text{W}}_L$ ) is asserted last.



## Architecture

The CY7C138AV/144AV/006AV/007AV and CY7C139AV/145AV/016AV/017AV consist of an array of 4K, 8K, 16K, and 32K words of 8 and 9 bits each of dual-port RAM cells, I/O and address lines, and control signals (CE, OE, R/W). These control pins permit independent access for reads or writes to any location in memory. To handle simultaneous writes/reads to the same location, a  $\overline{\text{BUSY}}$  pin is provided on each port. Two interrupt (INT) pins can be utilized for port-to-port communication. Two semaphore (SEM) control pins are used for allocating shared resources. With the M/S pin, the device can function as a master (BUSY pins are outputs) or as a slave (BUSY pins are inputs). The device also has an automatic power-down feature controlled by  $\overline{\text{CE}}$ . Each port is provided with its own output enable control (OE), which allows data to be read from the device.

## Functional Description

### Read and Write Operations

When writing data must be set up for a duration of  $t_{SD}$  before the rising edge of R/W in order to guarantee a valid write. A write operation is controlled by either the R/W pin (see Write Cycle No. 1 waveform) or the  $\overline{\text{CE}}$  pin (see Write Cycle No. 2 waveform). Required inputs for non-contention operations are summarized in Table 1.

If a location is being written to by one port and the opposite port attempts to read that location, a port-to-port flowthrough delay must occur before the data is read on the output; otherwise the data read is not deterministic. Data will be valid on the port  $t_{DD}$  after the data is presented on the other port.

When reading the device, the user must assert both the  $\overline{\text{OE}}$  and CE pins. Data will be available  $t_{ACE}$  after CE or  $t_{DOE}$  after OE is asserted. If the user wishes to access a semaphore flag, then the SEM pin must be asserted instead of the  $\overline{\text{CE}}$  pin and  $\overline{\text{OE}}$  must also be asserted.

### Interrupts

The upper two memory locations may be used for message passing. The highest memory location (FFF for the CY7C138AV/9AV, 1FFF for the CY7C144AV/5AV, 3FFF for the CY7C006AV/16AV, 7FFF for the CY7C007AV/17AV) is the mailbox for the right port and the second-highest memory location (FFE for the CY7C138AV/9AV, 1FFE for the CY7C144AV/5AV, 3FFE for the CY7C006AV/16AV, 7FFE for the CY7C007AV/17AV) is the mailbox for the left port. When one port writes to the other port's mailbox, an interrupt is generated to the owner. The interrupt is reset when the owner reads the contents of the mailbox. The message is user defined.

Each port can read the other port's mailbox without resetting the interrupt. The active state of the busy signal (to a port) prevents the port from setting the interrupt to the winning port. Also, an active busy to a port prevents that port from reading its own mailbox and, thus, resetting the interrupt to it. If an application does not require message passing, do not connect the interrupt pin to the processor's interrupt request input pin. The operation of the interrupts and their interaction with Busy are summarized in Table 2.

### Busy

The CY7C138AV/144AV/006AV/007AV and CY7C139AV/145AV/016AV/017AV provide on-chip arbitration to resolve simulta-

neous memory location access (contention). If both ports'  $\overline{\text{CE}}$ s are asserted and an address match occurs within  $t_{PS}$  of each other, the busy logic will determine which port has access. If  $t_{PS}$  is violated, one port will definitely gain permission to the location, but it is not predictable which port will get that permission.  $\overline{\text{BUSY}}$  will be asserted  $t_{BLA}$  after an address match or  $t_{BLC}$  after CE is taken LOW.

### Master/Slave

An M/S pin is provided in order to expand the word width by configuring the device as either a master or a slave. The  $\overline{\text{BUSY}}$  output of the master is connected to the  $\overline{\text{BUSY}}$  input of the slave. This will allow the device to interface to a master device with no external components. Writing to slave devices must be delayed until after the  $\overline{\text{BUSY}}$  input has settled ( $t_{BLC}$  or  $t_{BLA}$ ), otherwise, the slave chip may begin a write cycle during a contention situation. When tied HIGH, the M/S pin allows the device to be used as a master and, therefore, the  $\overline{\text{BUSY}}$  line is an output.  $\overline{\text{BUSY}}$  can then be used to send the arbitration outcome to a slave.

### Semaphore Operation

The CY7C138AV/144AV/006AV/007AV and CY7C139AV/145AV/016AV/017AV provide eight semaphore latches, which are separate from the dual-port memory locations. Semaphores are used to reserve resources that are shared between the two ports. The state of the semaphore indicates that a resource is in use. For example, if the left port wants to request a given resource, it sets a latch by writing a zero to a semaphore location. The left port then verifies its success in setting the latch by reading it. After writing to the semaphore, SEM or OE must be deasserted for  $t_{SOP}$  before attempting to read the semaphore. The semaphore value will be available  $t_{SWRD} + t_{DOE}$  after the rising edge of the semaphore write. If the left port was successful (reads a zero), it assumes control of the shared resource, otherwise (reads a one) it assumes the right port has control and continues to poll the semaphore. When the right side has relinquished control of the semaphore (by writing a one), the left side will succeed in gaining control of the semaphore. If the left side no longer requires the semaphore, a one is written to cancel its request.

Semaphores are accessed by asserting  $\overline{\text{SEM}}$  LOW. The SEM pin functions as a chip select for the semaphore latches (CE must remain HIGH during SEM LOW).  $A_{0-2}$  represents the semaphore address. OE and R/W are used in the same manner as a normal memory access. When writing or reading a semaphore, the other address pins have no effect.

When writing to the semaphore, only I/O<sub>0</sub> is used. If a zero is written to the left port of an available semaphore, a one will appear at the same semaphore address on the right port. That semaphore can now only be modified by the side showing zero (the left port in this case). If the left port now relinquishes control by writing a one to the semaphore, the semaphore will be set to one for both sides. However, if the right port had requested the semaphore (written a zero) while the left port had control, the right port would immediately own the semaphore as soon as the left port released it. Table 3 shows sample semaphore operations.

When reading a semaphore, all data lines output the semaphore value. The read value is latched in an output register to prevent the semaphore from changing state during a write from the other port. If both ports attempt to access the semaphore within  $t_{SPS}$  of each other, the semaphore will definitely be obtained by one side or the other, but there is no guarantee which side will control the semaphore.



Table 1. Non-Contending Read/Write

Inputs				Outputs	Operation
CE	R/W	OE	SEM	I/O <sub>0</sub> -I/O <sub>8</sub>	
H	X	X	H	High Z	Deselected: Power-Down
H	H	L	L	Data Out	Read Data in Semaphore Flag
X	X	H	X	High Z	I/O Lines Disabled
H		X	L	Data In	Write into Semaphore Flag
L	H	L	H	Data Out	Read
L	L	X	H	Data In	Write
L	X	X	L		Not Allowed

Table 2. Interrupt Operation Example (assumes  $\overline{\text{BUSY}}_L = \overline{\text{BUSY}}_R = \text{HIGH}$ )

Function	Left Port					Right Port				
	$\overline{\text{R/W}}_L$	$\overline{\text{CE}}_L$	$\overline{\text{OE}}_L$	A <sub>0L-14L</sub>	$\overline{\text{INT}}_L$	$\overline{\text{R/W}}_R$	$\overline{\text{CE}}_R$	$\overline{\text{OE}}_R$	A <sub>0R-14R</sub>	$\overline{\text{INT}}_R$
Set Right $\overline{\text{INT}}_R$ Flag	L	L	X	FFF <sup>[45]</sup>	X	X	X	X	X	L <sup>[46]</sup>
Reset Right $\overline{\text{INT}}_R$ Flag	X	X	X	X	X	X	L	L	FFF <sup>[45]</sup>	H <sup>[47]</sup>
Set Left $\overline{\text{INT}}_L$ Flag	X	X	X	X	L <sup>[47]</sup>	L	L	X	1FFE <sup>[45]</sup>	X
Reset Left $\overline{\text{INT}}_L$ Flag	X	L	L	1FFE <sup>[45]</sup>	H <sup>[46]</sup>	X	X	X	X	X

Table 3. Semaphore Operation Example

Function	I/O <sub>0</sub> -I/O <sub>8</sub> Left	I/O <sub>0</sub> -I/O <sub>8</sub> Right	Status
No action	1	1	Semaphore free
Left port writes 0 to semaphore	0	1	Left Port has semaphore token
Right port writes 0 to semaphore	0	1	No change. Right side has no write access to semaphore
Left port writes 1 to semaphore	1	0	Right port obtains semaphore token
Left port writes 0 to semaphore	1	0	No change. Left port has no write access to semaphore
Right port writes 1 to semaphore	0	1	Left port obtains semaphore token
Left port writes 1 to semaphore	1	1	Semaphore free
Right port writes 0 to semaphore	1	0	Right port has semaphore token
Right port writes 1 to semaphore	1	1	Semaphore free
Left port writes 0 to semaphore	0	1	Left port has semaphore token
Left port writes 1 to semaphore	1	1	Semaphore free

Note:

45. See Functional Description for specific addresses by device part number.

46. If  $\overline{\text{BUSY}}_L = L$ , then no change.

47. If  $\overline{\text{BUSY}}_R = L$ , then no change.



**Ordering Information**

**Package Availability Guide**

Device	Organization	68-Pin PLCC	64-Pin TQFP
CY7C138AV	4K x 8	X	
CY7C139AV	4K x 9	X	
CY7C144AV	8K x 8	X	X
CY7C145AV	8K x 9	X	
CY7C006AV	16K x 8	X	X
CY7C016AV	16K x 9	X	
CY7C007AV	32K x 8	X	
CY7C017AV	32K x 9	X	

**4K x8 3.3V Asynchronous Dual-Port SRAM**

Speed (ns)	Ordering Code	Package Name	Package Type	Operating Range
20	CY7C138AV-20JC	J81	68-Pin Plastic Leaded Chip Carrier	Commercial
25	CY7C138AV-25JC	J81	68-Pin Plastic Leaded Chip Carrier	Commercial

**4K x9 3.3V Asynchronous Dual-Port SRAM**

Speed (ns)	Ordering Code	Package Name	Package Type	Operating Range
20	CY7C139AV-20JC	J81	68-Pin Plastic Leaded Chip Carrier	Commercial
25	CY7C139AV-25JC	J81	68-Pin Plastic Leaded Chip Carrier	Commercial

**8K x8 3.3V Asynchronous Dual-Port SRAM**

Speed (ns)	Ordering Code	Package Name	Package Type	Operating Range
20	CY7C144AV-20AC	A65	64-Pin Thin Quad Flat Pack	Commercial
	CY7C144AV-20JC	J81	68-Pin Plastic Leaded Chip Carrier	
25	CY7C144AV-25AC	A65	64-Pin Thin Quad Flat Pack	Commercial
	CY7C144AV-25JC	J81	68-Pin Plastic Leaded Chip Carrier	

**8K x9 3.3V Asynchronous Dual-Port SRAM**

Speed (ns)	Ordering Code	Package Name	Package Type	Operating Range
20	CY7C145AV-20JC	J81	68-Pin Plastic Leaded Chip Carrier	Commercial
25	CY7C145AV-25JC	J81	68-Pin Plastic Leaded Chip Carrier	Commercial

**16K x8 3.3V Asynchronous Dual-Port SRAM**

Speed (ns)	Ordering Code	Package Name	Package Type	Operating Range
20	CY7C006AV-20AC	A65	64-Pin Thin Quad Flat Pack	Commercial
	CY7C006AV-20JC	J81	68-Pin Plastic Leaded Chip Carrier	
25	CY7C006AV-25AC	A65	64-Pin Thin Quad Flat Pack	Commercial
	CY7C006AV-25JC	J81	68-Pin Plastic Leaded Chip Carrier	



**Ordering Information** (continued)

**16K x9 3.3V Asynchronous Dual-Port SRAM**

Speed (ns)	Ordering Code	Package Name	Package Type	Operating Range
20	CY7C016AV-20JC	J81	68-Pin Plastic Leaded Chip Carrier	Commercial
25	CY7C016AV-25JC	J81	68-Pin Plastic Leaded Chip Carrier	Commercial

**32K x8 3.3V Asynchronous Dual-Port SRAM**

Speed (ns)	Ordering Code	Package Name	Package Type	Operating Range
20	CY7C007AV-20JC	J81	68-Pin Plastic Leaded Chip Carrier	Commercial
	CY7C007AV-20JI	J81	68-Pin Plastic Leaded Chip Carrier	Industrial
25	CY7C007AV-25JC	J81	68-Pin Plastic Leaded Chip Carrier	Commercial

**32K x9 3.3V Asynchronous Dual-Port SRAM**

Speed (ns)	Ordering Code	Package Name	Package Type	Operating Range
20	CY7C017AV-20JC	J81	68-Pin Plastic Leaded Chip Carrier	Commercial
	CY7C017AV-20JI	J81	68-Pin Plastic Leaded Chip Carrier	Industrial
25	CY7C017AV-25JC	J81	68-Pin Plastic Leaded Chip Carrier	Commercial



CY7C138AV/144AV/006AV  
 CY7C139AV/145AV/016AV  
 CY7C007AV/017AV

Package Diagrams

64-Lead Thin Plastic Quad Flat Pack (14 x 14 x 1.4 mm) A65

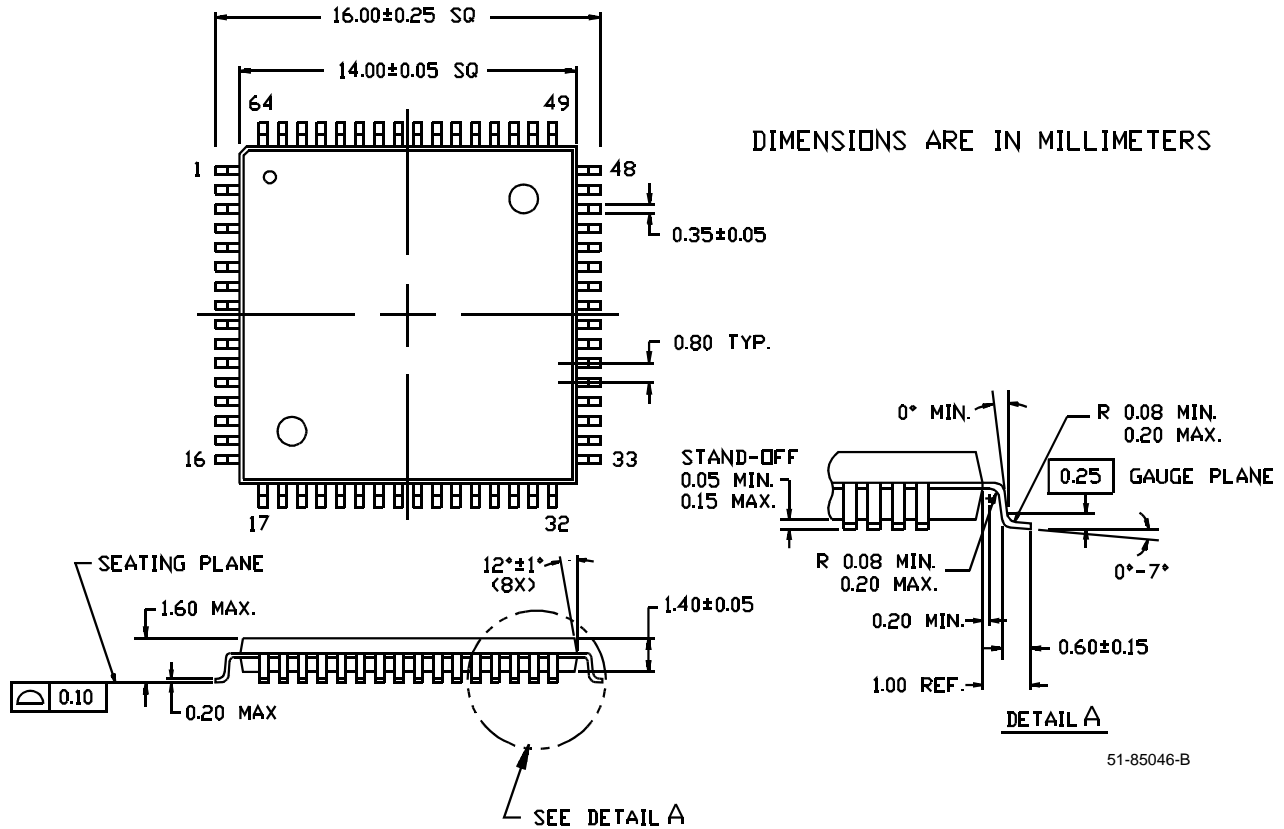

68-Lead Plastic Leaded Chip Carrier J81

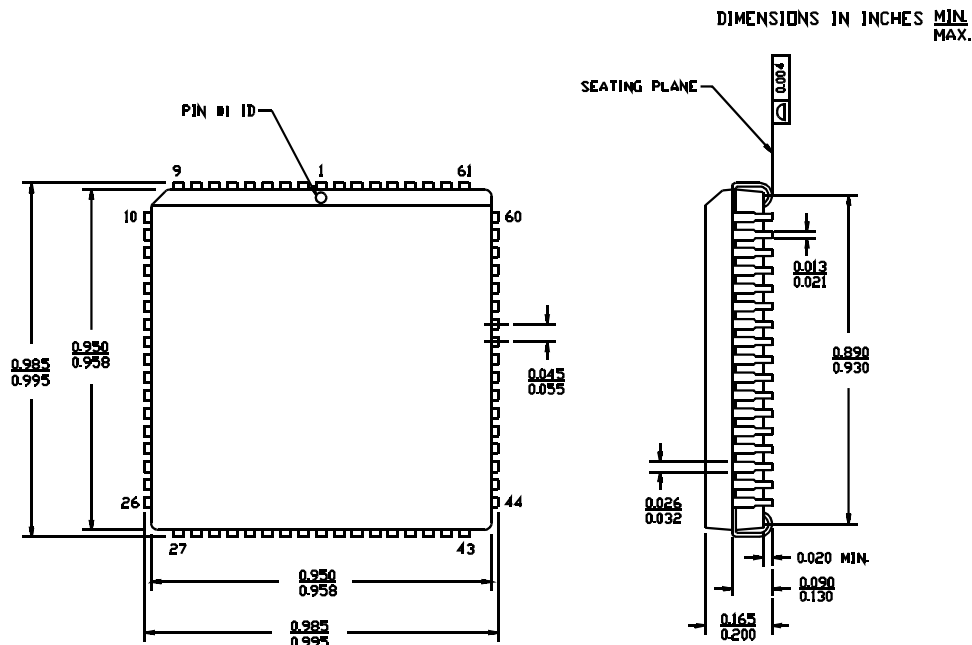



**CY7C138AV/144AV/006AV**  
**CY7C139AV/145AV/016AV**  
**CY7C007AV/017AV**

**Document Title: CY7C138AV/144AV/006AV/CY7C139AV/145AV/016AV/CY7C007AV/017AV 3.3V 4K/8K/16K/32K x 8/9  
Dual Port SRAM  
Document Number: 38-06051**

<b>REV.</b>	<b>ECN NO.</b>	<b>Issue Date</b>	<b>Orig. of Change</b>	<b>Description of Change</b>
**	110203	12/02/01	SZV	Change from Spec number: 38-00837 to 38-06051
*A	122301	12/27/02	RBI	Power up requirements added to Maximum Ratings Information