

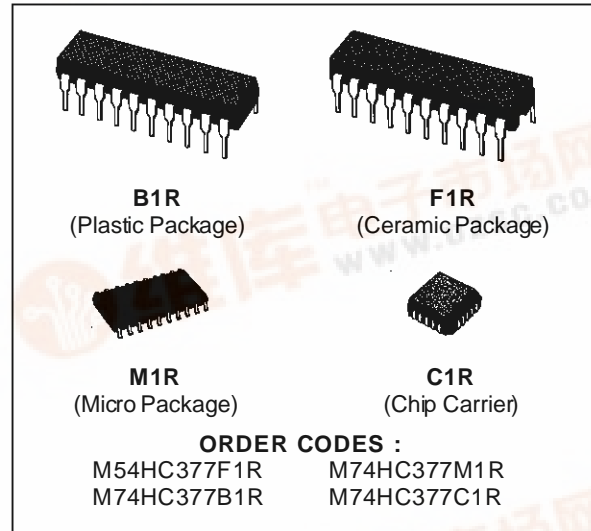

M54HC377
M74HC377

OCTAL D TYPE FLIP FLOP

- HIGH SPEED
f_{MAX} = 73 MHz (TYP.) at V_{CC} = 5 V
- LOW POWER DISSIPATION
I_{CC} = 4 μA (MAX.) at 25 °C
- HIGH NOISE IMMUNITY
V_{NIH} = V_{NIL} = 28 % V_{CC} (MIN.)
- OUTPUT DRIVE CAPABILITY
10 LSTTL LOADS
- SYMMETRICAL OUTPUT IMPEDANCE
|I_{OH}| = I_{OL} = 4 mA (MIN.)
- BALANCED PROPAGATION DELAYS
t_{PLH} = t_{PHL}
- WIDE OPERATING VOLTAGE RANGE
V_{CC} (OPR) = 2 V to 6 V
- PIN AND FUNCTION COMPATIBLE WITH
54/74LS377



DESCRIPTION

The M54/74HC377 is a high speed CMOS OCTAL-D-TYPE FLIP FLOP fabricated in silicon gate C²MOS technology. It has the same high speed performance of LSTTL combined with true CMOS low power consumption.

Information at the D inputs meeting the setup time requirements is transferred to the Q outputs on the positive-going edge of the clock pulse if the enable input \bar{G} is low. Clock triggering occurs at a particular voltage level and is not directly related to the transition time of the positive-going pulse. When the clock input is at either the high or low level, the D input signal has no effect at the output. All inputs are equipped with protection circuits against static discharge and transient excess voltage.

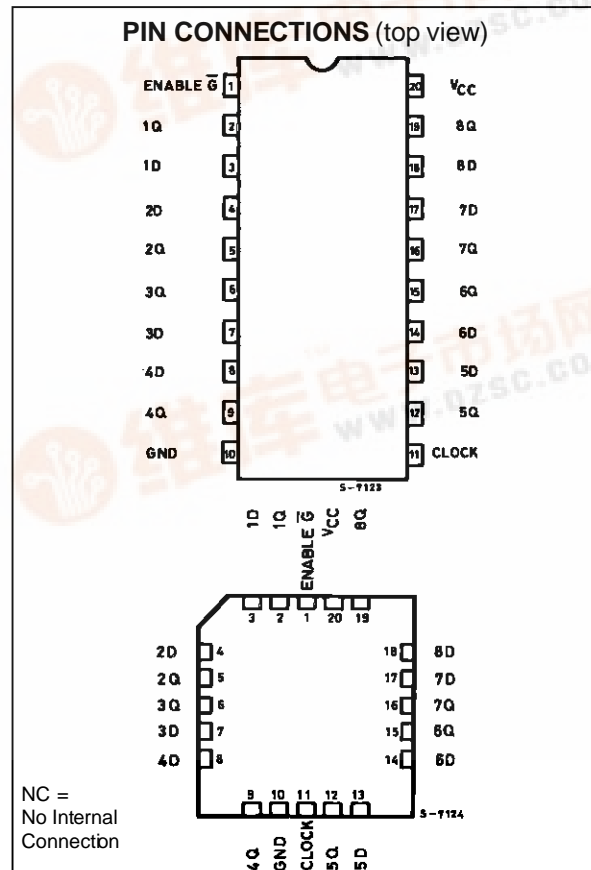

M54/M74HC377

INPUT AND OUTPUT EQUIVALENT CIRCUIT

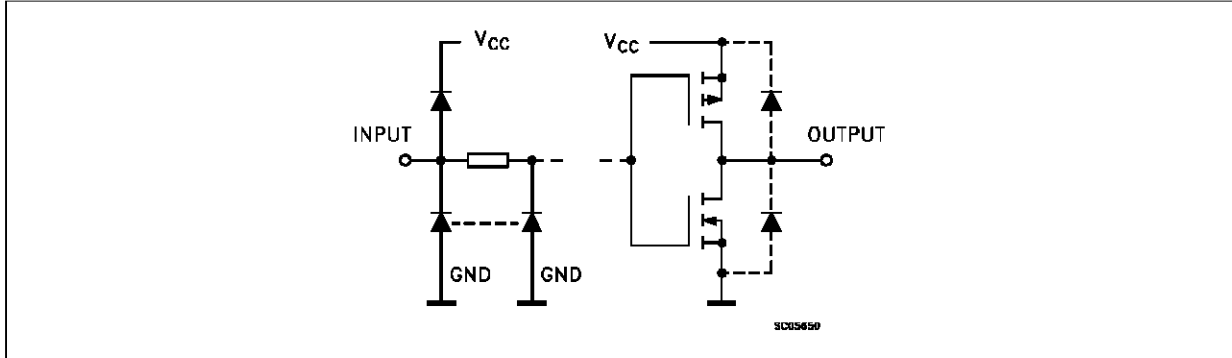

TRUTH TABLE

\overline{G}	INPUTS		OUTPUT
	CLOCK	DATA	Q
H	X	X	NO CHANGE
L		L	L
L		H	H
X		X	NO CHANGE

X: DON'T CARE

LOGIC DIAGRAM

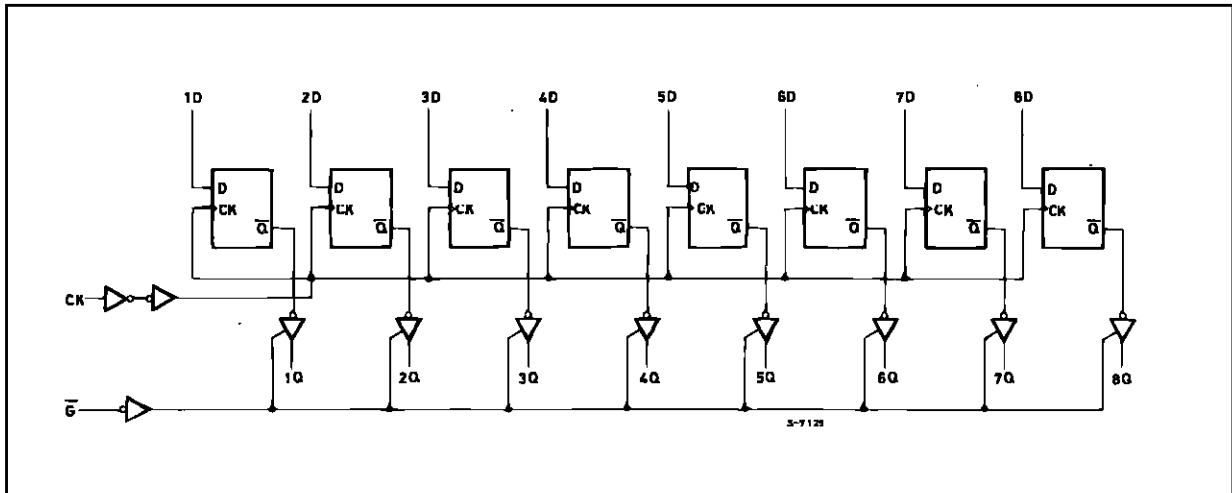

PIN DESCRIPTION

PIN No	SYMBOL	NAME AND FUNCTION
1	ENABLE \bar{G}	Data Enable Input (Active LOW)
2, 5, 6, 9, 12, 15, 16, 19	1Q to 8Q	Flip Flop Outputs
3, 4, 7, 8, 13, 14, 17, 18	1D to 8D	Data Inputs
11	CLOCK	Clock Input (LOW to HIGH, Edge-triggered)
10	GND	Ground (0V)
20	V _{CC}	Positive Supply Voltage

IEC LOGIC SYMBOL

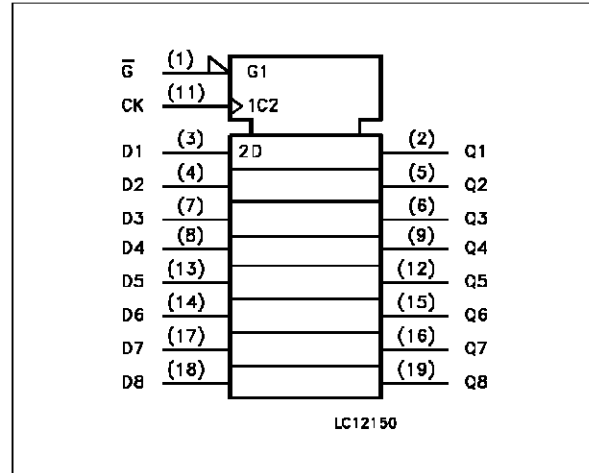

ABSOLUTE MAXIMUM RATINGS

Symbol	Parameter	Value	Unit
V _{CC}	Supply Voltage	-0.5 to +7	V
V _I	DC Input Voltage	-0.5 to V _{CC} + 0.5	V
V _O	DC Output Voltage	-0.5 to V _{CC} + 0.5	V
I _{IK}	DC Input Diode Current	± 20	mA
I _{OK}	DC Output Diode Current	± 20	mA
I _O	DC Output Source Sink Current Per Output Pin	± 25	mA
I _{CC} or I _{GND}	DC V _{CC} or Ground Current	± 50	mA
P _D	Power Dissipation	500 (*)	mW
T _{stg}	Storage Temperature	-65 to +150	°C
T _L	Lead Temperature (10 sec)	300	°C

Absolute Maximum Ratings are those values beyond which damage to the device may occur. Functional operation under these condition is not implied.

(*) 500 mW: ≡ 65 °C derate to 300 mW by 10mW/°C: 65 °C to 85 °C

RECOMMENDED OPERATING CONDITIONS

Symbol	Parameter	Value	Unit	
V _{CC}	Supply Voltage	2 to 6	V	
V _I	Input Voltage	0 to V _{CC}	V	
V _O	Output Voltage	0 to V _{CC}	V	
T _{op}	Operating Temperature: M54HC Series M74HC Series	-55 to +125 -40 to +85	°C °C	
t _r , t _f	Input Rise and Fall Time	V _{CC} = 2 V V _{CC} = 4.5 V V _{CC} = 6 V	0 to 1000 0 to 500 0 to 400	ns

M54/M74HC377

DC SPECIFICATIONS

Symbol	Parameter	Test Conditions		Value						Unit		
		V _{CC} (V)		T _A = 25 °C 54HC and 74HC			-40 to 85 °C 74HC		-55 to 125 °C 54HC			
				Min.	Typ.	Max.	Min.	Max.	Min.		Max.	
V _{IH}	High Level Input Voltage	2.0		1.5			1.5		1.5		V	
		4.5		3.15			3.15		3.15			
		6.0		4.2			4.2		4.2			
V _{IL}	Low Level Input Voltage	2.0				0.5		0.5		0.5	V	
		4.5				1.35		1.35		1.35		
		6.0				1.8		1.8		1.8		
V _{OH}	High Level Output Voltage	2.0	V _I = V _{IH} or V _{IL}	I _O = -20 μA	1.9	2.0		1.9		1.9	V	
		4.5			4.4	4.5		4.4		4.4		
		6.0			5.9	6.0		5.9		5.9		
		4.5	I _O = -4.0 mA	4.18	4.31		4.13		4.10			
		6.0	I _O = -5.2 mA	5.68	5.8		5.63		5.60			
V _{OL}	Low Level Output Voltage	2.0	V _I = V _{IH} or V _{IL}	I _O = 20 μA		0.0	0.1		0.1		0.1	V
		4.5				0.0	0.1		0.1		0.1	
		6.0				0.0	0.1		0.1		0.1	
		4.5		I _O = 4.0 mA		0.17	0.26		0.33		0.40	
		6.0		I _O = 5.2 mA		0.18	0.26		0.33		0.40	
I _I	Input Leakage Current	6.0	V _I = V _{CC} or GND			±0.1		±1		±1	μA	
I _{CC}	Quiescent Supply Current	6.0	V _I = V _{CC} or GND			4		40		80	μA	

AC ELECTRICAL CHARACTERISTICS ($C_L = 50$ pF, Input $t_r = t_f = 6$ ns)

Symbol	Parameter	Test Conditions		Value						Unit	
				$T_A = 25\text{ }^\circ\text{C}$ 54HC and 74HC			-40 to $85\text{ }^\circ\text{C}$ 74HC		-55 to $125\text{ }^\circ\text{C}$ 54HC		
				Min.	Typ.	Max.	Min.	Max.	Min.		Max.
t_{TLH} t_{THL}	Output Transition Time	2.0			30	75		95		110	ns
		4.5			8	15		19		22	
		6.0			7	13		16		19	
t_{PLH} t_{PHL}	Propagation Delay Time (CLOCK - Q)	2.0			57	140		175		210	ns
		4.5			17	28		35		42	
		6.0			13	24		30		36	
f_{MAX}	Maximum Clock Frequency	2.0		7.2	14		5.8		4.8		MHz
		4.5		36	56		29		24		
		6.0		42	66		34		28		
$t_{W(H)}$ $t_{W(L)}$	Minimum Pulse Width (CLOCK)	2.0			24	75		95		115	ns
		4.5			6	15		19		23	
		6.0			5	13		16		20	
t_s	Minimum Set-up Time (D - CK)	2.0			24	75		95		115	ns
		4.5			6	15		19		23	
		6.0			5	13		16		20	
t_s	Minimum Set-up Time (G - CK)	2.0			30	75		95		115	ns
		4.5			8	15		19		23	
		6.0			6	13		16		20	
t_h	Minimum Hold Time	2.0				0		0		0	ns
		4.5				0		0		0	
		6.0				0		0		0	
C_{IN}	Input Capacitance				5	10		10		10	pF
C_{PD} (*)	Power Dissipation Capacitance				34						pF

(*) C_{PD} is defined as the value of the IC's internal equivalent capacitance which is calculated from the operating current consumption without load. (Refer to Test Circuit). Average operating current can be obtained by the following equation. $I_{CC(opr)} = C_{PD} \cdot V_{CC} \cdot f_{IN} + I_{CC}$

M54/M74HC377

SWITCHING CHARACTERISTICS TEST WAVEFORM

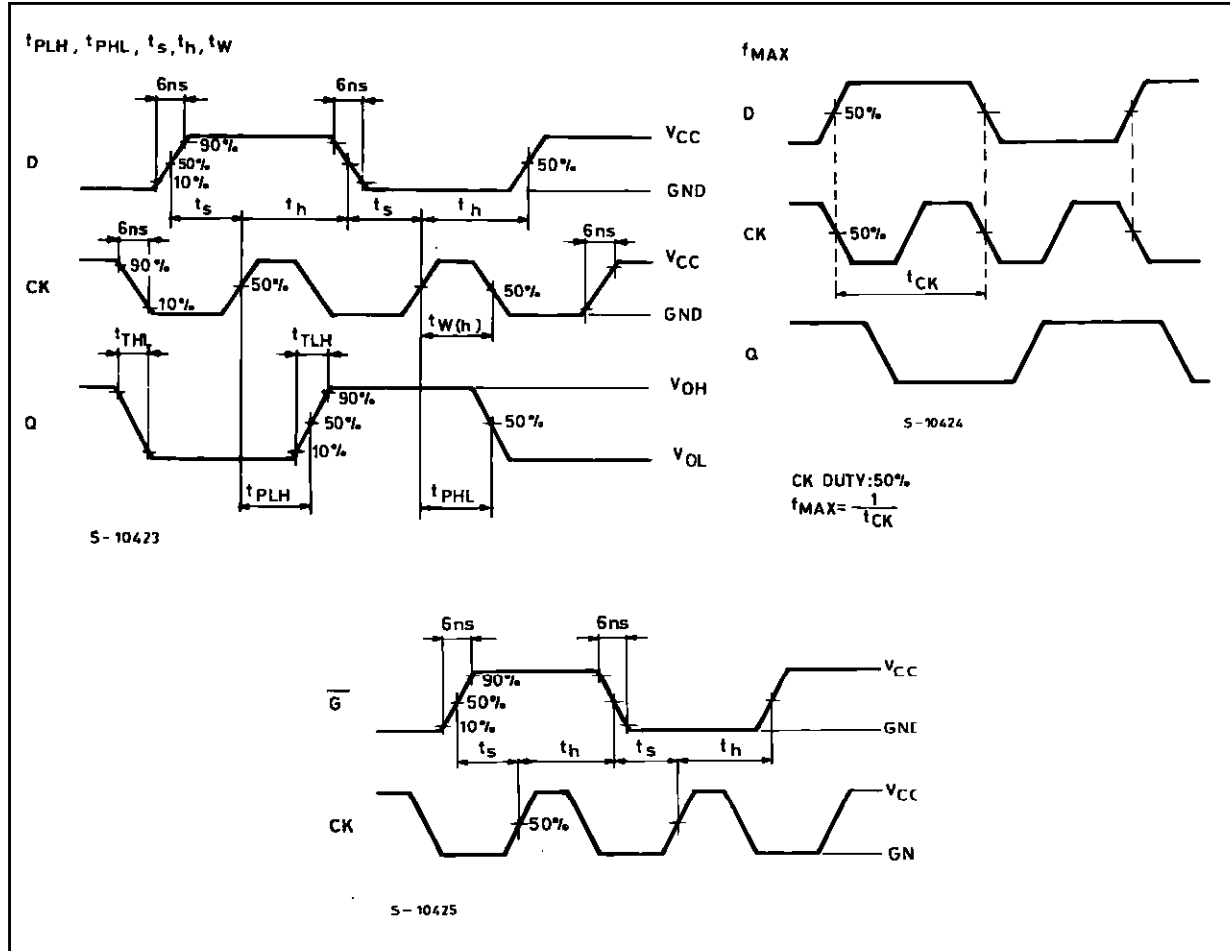

TEST CIRCUIT I_{CC} (Opr.)

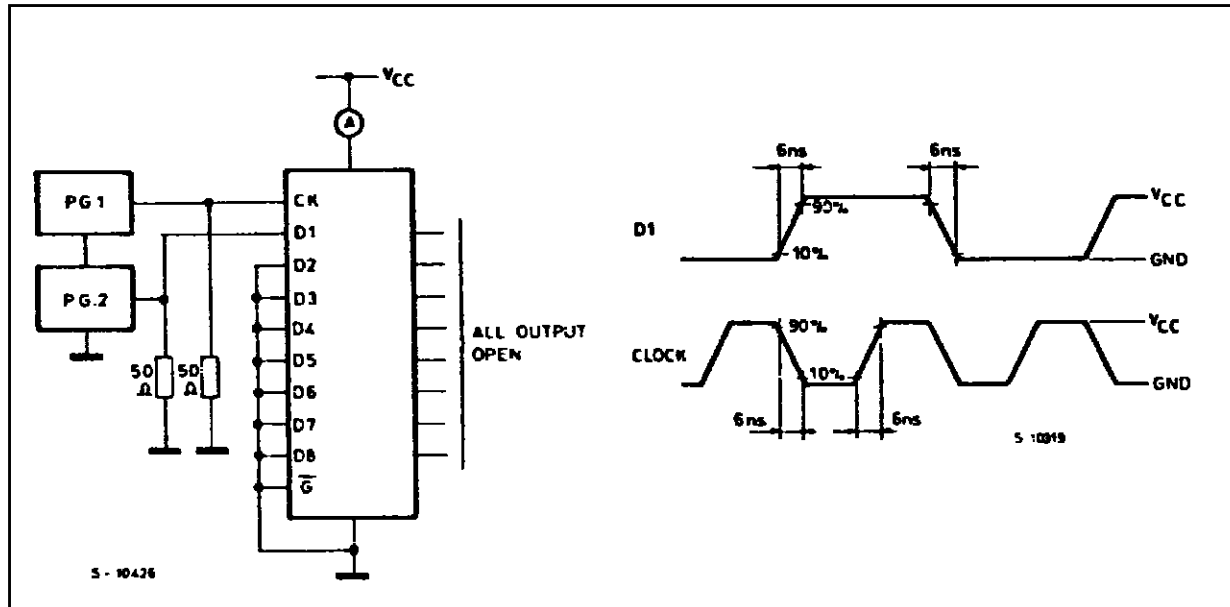

Plastic DIP20 (0.25) MECHANICAL DATA

DIM.	mm			inch		
	MIN.	TYP.	MAX.	MIN.	TYP.	MAX.
a1	0.254			0.010		
B	1.39		1.65	0.055		0.065
b		0.45			0.018	
b1		0.25			0.010	
D			25.4			1.000
E		8.5			0.335	
e		2.54			0.100	
e3		22.86			0.900	
F			7.1			0.280
l			3.93			0.155
L		3.3			0.130	
Z			1.34			0.053

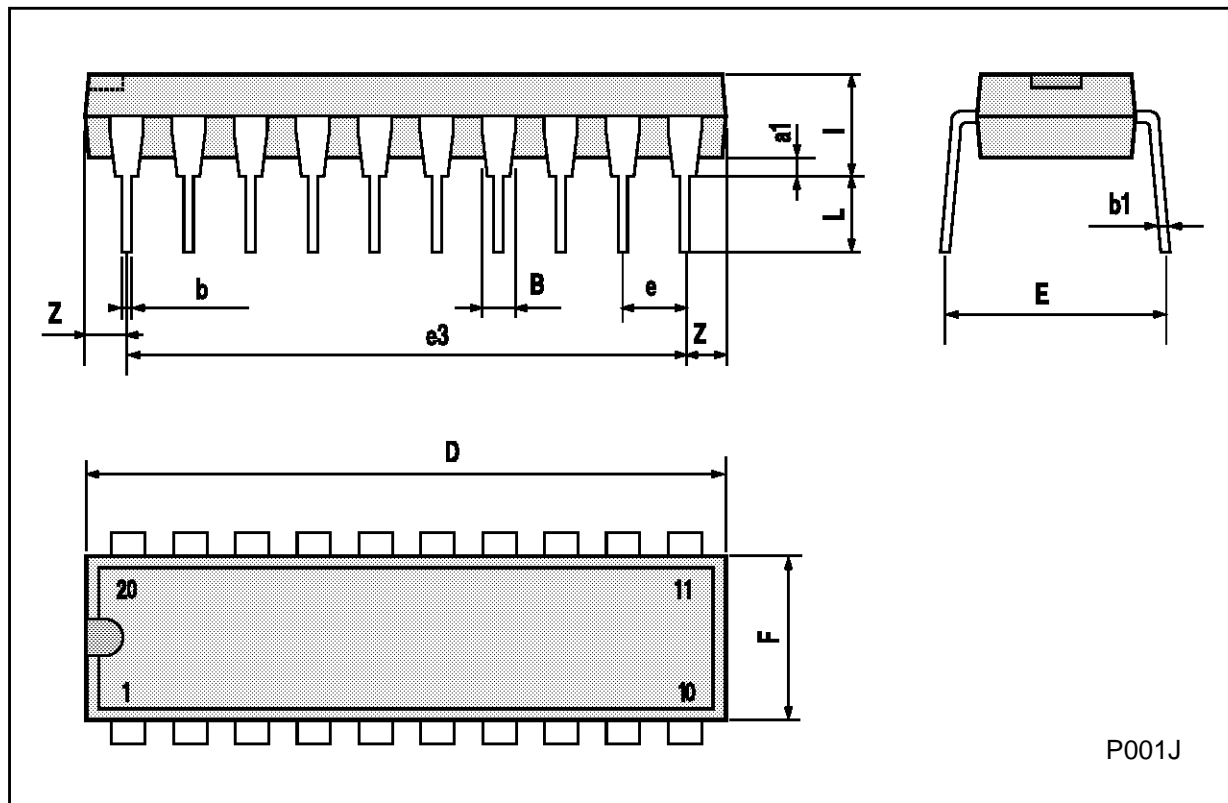

Ceramic DIP20 MECHANICAL DATA

DIM.	mm			inch		
	MIN.	TYP.	MAX.	MIN.	TYP.	MAX.
A			25			0.984
B			7.8			0.307
D		3.3			0.130	
E	0.5		1.78	0.020		0.070
e3		22.86			0.900	
F	2.29		2.79	0.090		0.110
G	0.4		0.55	0.016		0.022
I	1.27		1.52	0.050		0.060
L	0.22		0.31	0.009		0.012
M	0.51		1.27	0.020		0.050
N1	4° (min.), 15° (max.)					
P	7.9		8.13	0.311		0.320
Q			5.71			0.225

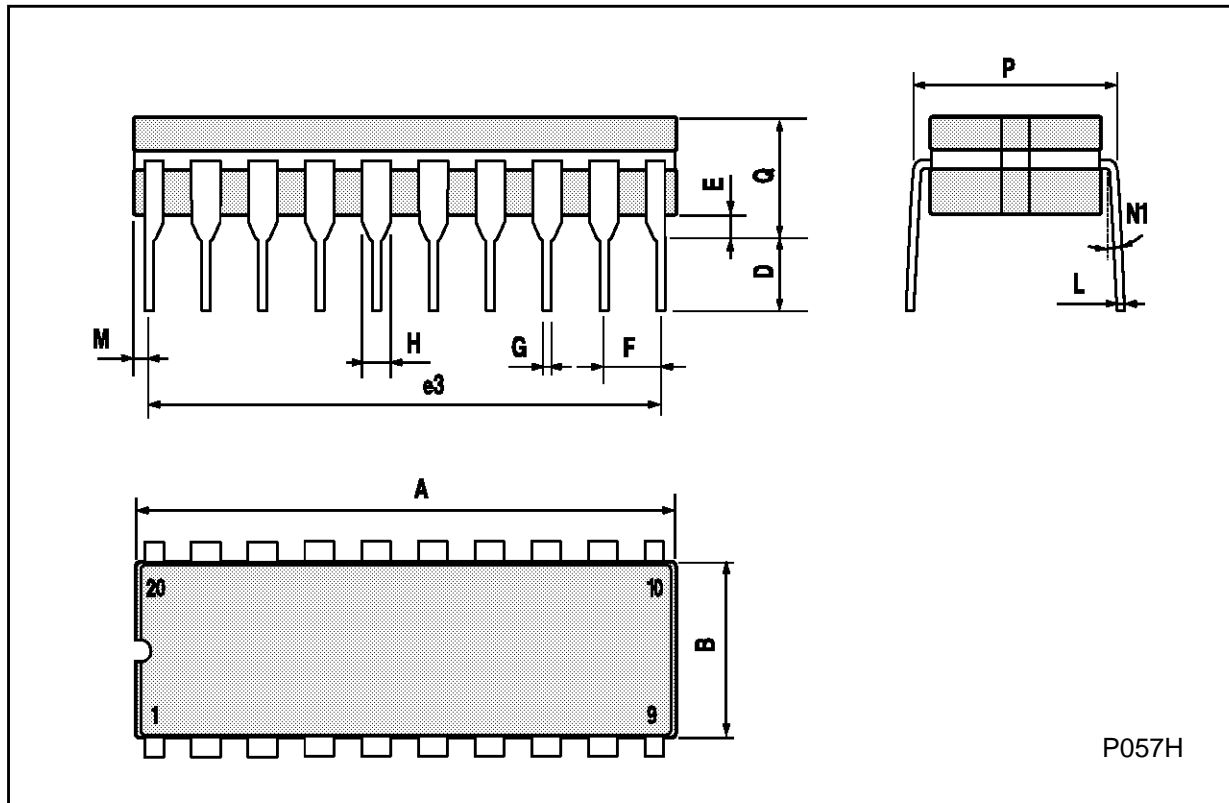

SO20 MECHANICAL DATA

DIM.	mm			inch		
	MIN.	TYP.	MAX.	MIN.	TYP.	MAX.
A			2.65			0.104
a1	0.10		0.20	0.004		0.007
a2			2.45			0.096
b	0.35		0.49	0.013		0.019
b1	0.23		0.32	0.009		0.012
C		0.50			0.020	
c1	45° (typ.)					
D	12.60		13.00	0.496		0.512
E	10.00		10.65	0.393		0.419
e		1.27			0.050	
e3		11.43			0.450	
F	7.40		7.60	0.291		0.299
L	0.50		1.27	0.19		0.050
M			0.75			0.029
S	8° (max.)					

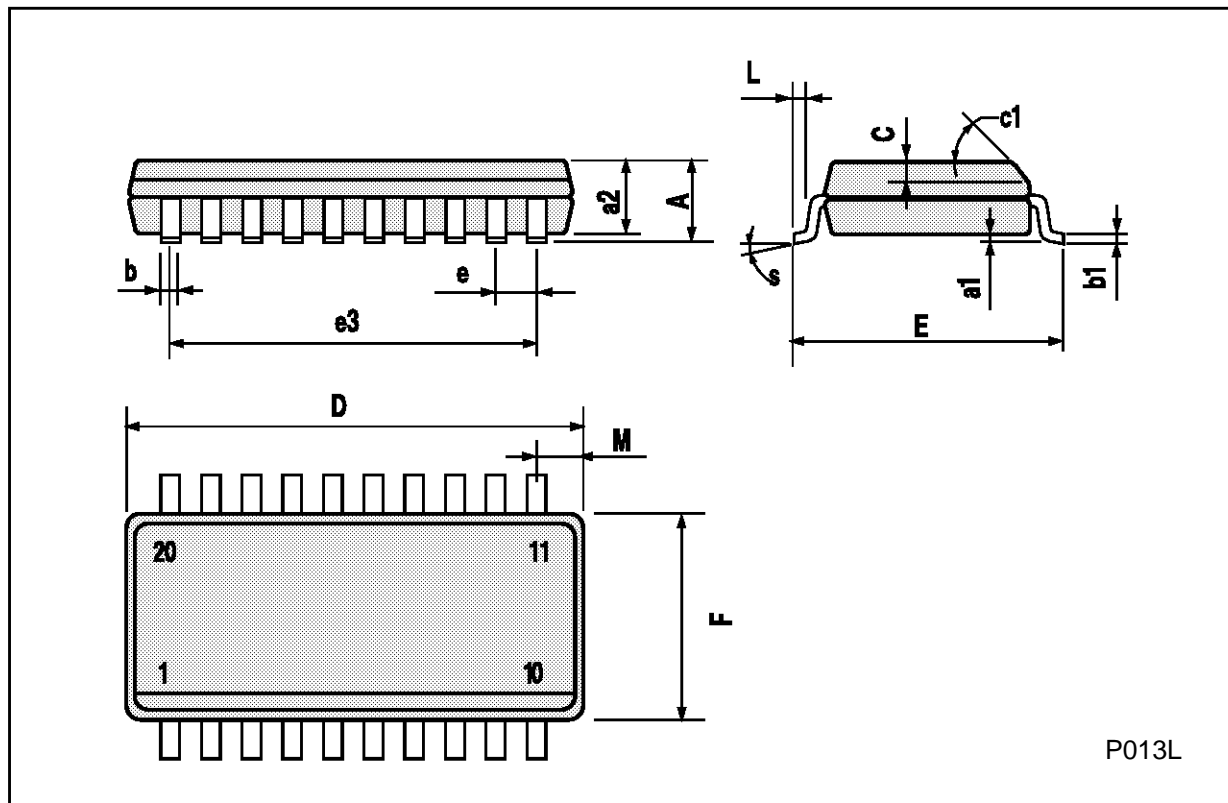

PLCC20 MECHANICAL DATA

DIM.	mm			inch		
	MIN.	TYP.	MAX.	MIN.	TYP.	MAX.
A	9.78		10.03	0.385		0.395
B	8.89		9.04	0.350		0.356
D	4.2		4.57	0.165		0.180
d1		2.54			0.100	
d2		0.56			0.022	
E	7.37		8.38	0.290		0.330
e		1.27			0.050	
e3		5.08			0.200	
F		0.38			0.015	
G			0.101			0.004
M		1.27			0.050	
M1		1.14			0.045	

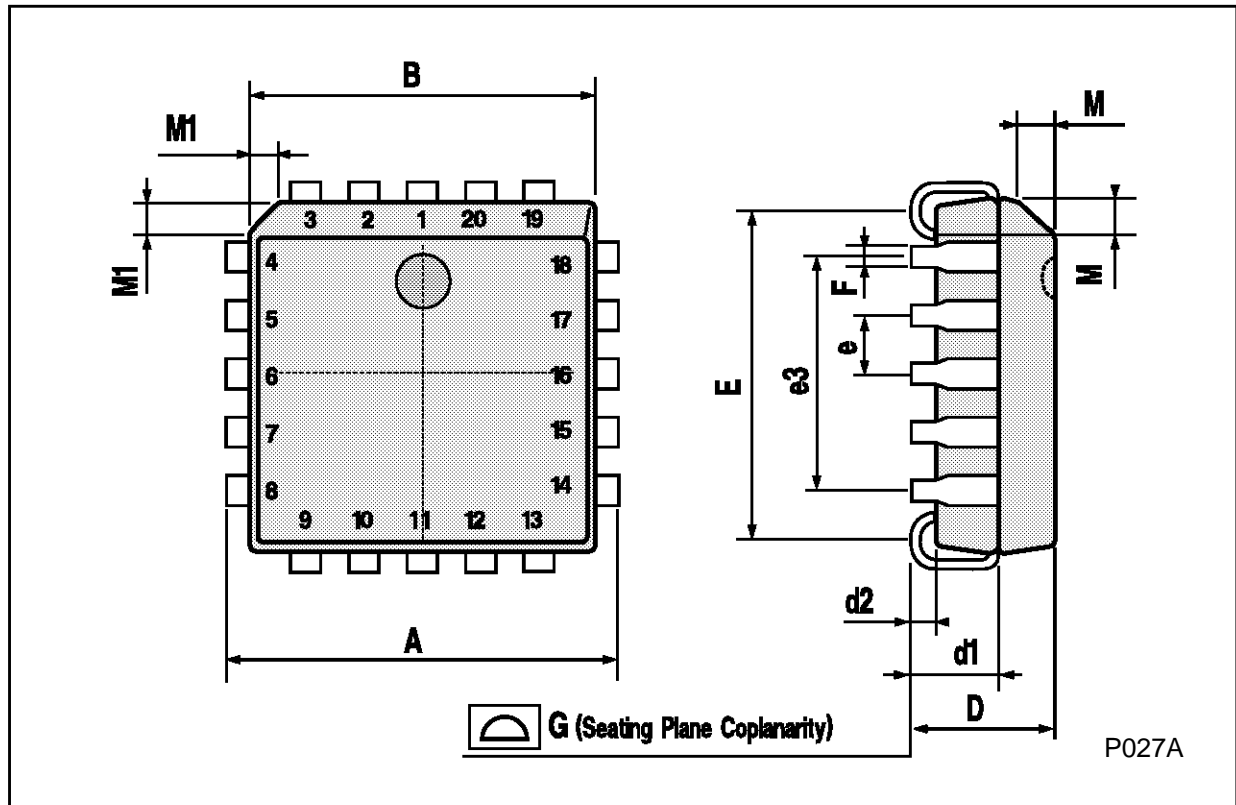

Information furnished is believed to be accurate and reliable. However, SGS-THOMSON Microelectronics assumes no responsibility for the consequences of use of such information nor for any infringement of patents or other rights of third parties which may result from its use. No license is granted by implication or otherwise under any patent or patent rights of SGS-THOMSON Microelectronics. Specifications mentioned in this publication are subject to change without notice. This publication supersedes and replaces all information previously supplied. SGS-THOMSON Microelectronics products are not authorized for use as critical components in life support devices or systems without express written approval of SGS-THOMSON Microelectronics.

© 1994 SGS-THOMSON Microelectronics - All Rights Reserved

SGS-THOMSON Microelectronics GROUP OF COMPANIES
Australia - Brazil - France - Germany - Hong Kong - Italy - Japan - Korea - Malaysia - Malta - Morocco - The Netherlands -
Singapore - Spain - Sweden - Switzerland - Taiwan - Thailand - United Kingdom - U.S.A