

8205

Data Sheet
27468.20

PRELIMINARY INFORMATION
(subject to change without notice)
December 6, 1999

LOW-DROPOUT REGULATORS — HIGH EFFICIENCY

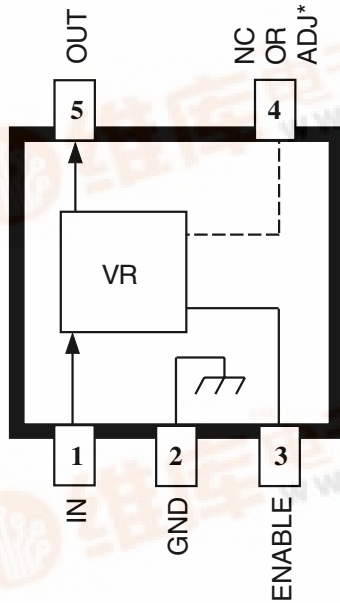

Dwg. PS-021-5

*NO CONNECTION (fixed regulators) or ADJUST (A8205SLH-ADJ only).

Designed specifically to meet the requirement for extended operation of battery-powered equipment such as cordless and cellular telephones, the A8205SLH voltage regulators offer the reduced dropout voltage and quiescent current essential for maximum battery life. Applicable also to palmtop computers and personal data assistants, these devices deliver a regulated output at up to 200 mA (transient), which is limited only by package power dissipation. Regulated output voltages of 2.7, 2.8, 3.0, 3.3, 3.6, 4.0, and 5.0 V are currently provided. Other voltages, down to 2.0 volts, are available on special order.

A PMOS pass element provides a typical dropout voltage of only 75 mV at 100 mA of load current. The low dropout voltage permits deeper battery discharge before output regulation is lost. Quiescent current does not increase significantly as the dropout voltage is approached, an ideal feature in standby/resume power systems where data integrity is crucial. Regulator accuracy and excellent temperature characteristics are provided by a bandgap reference. The A8205SLH includes an ENABLE input to give the designer complete control over power up, standby, or power down.

These devices are supplied in a thermally enhanced 5-lead small-outline plastic package similar to the SOT-23, and fitting the SC-74A footprint. All devices are rated for operation over a temperature range of -20°C to +85°C.

ABSOLUTE MAXIMUM RATINGS

Input Voltage, V_I	7 V
Peak Output Current, I_{OM}	200 mA*
Enable Input Voltage, V_E	V_I
Operating Temperature Range, T_A	-20°C to +85°C
Junction Temperature, T_J	+150°C
Storage Temperature Range, T_S	-40°C to +150°C

* Output current rating is limited by input voltage, duty cycle, and ambient temperature. Under any set of conditions, do not exceed a junction temperature of +150°C. See following pages.

FEATURES AND BENEFITS

- High Efficiency Provides Extended Battery Life
- 75 mV Typical Dropout Voltage at $I_O = 100$ mA
- 55 μ A Typical Quiescent Current
Less Than 1 μ A "Sleep" Current
- Low Output Noise
- 200 mA Peak Output Current
- Improved PSRR and Transient Performance

APPLICATIONS

- Cordless and Cellular Telephones
- Personal Data Assistants
- Personal Communicators
- Palmtop Computers

Always order by complete part number, e.g., **A8205SLH-xx**, where "xx" is the required output voltage in tenths or "ADJ" for adjustable.

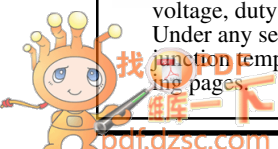

8205 LOW-DROPOUT REGULATORS

FUNCTIONAL BLOCK DIAGRAM

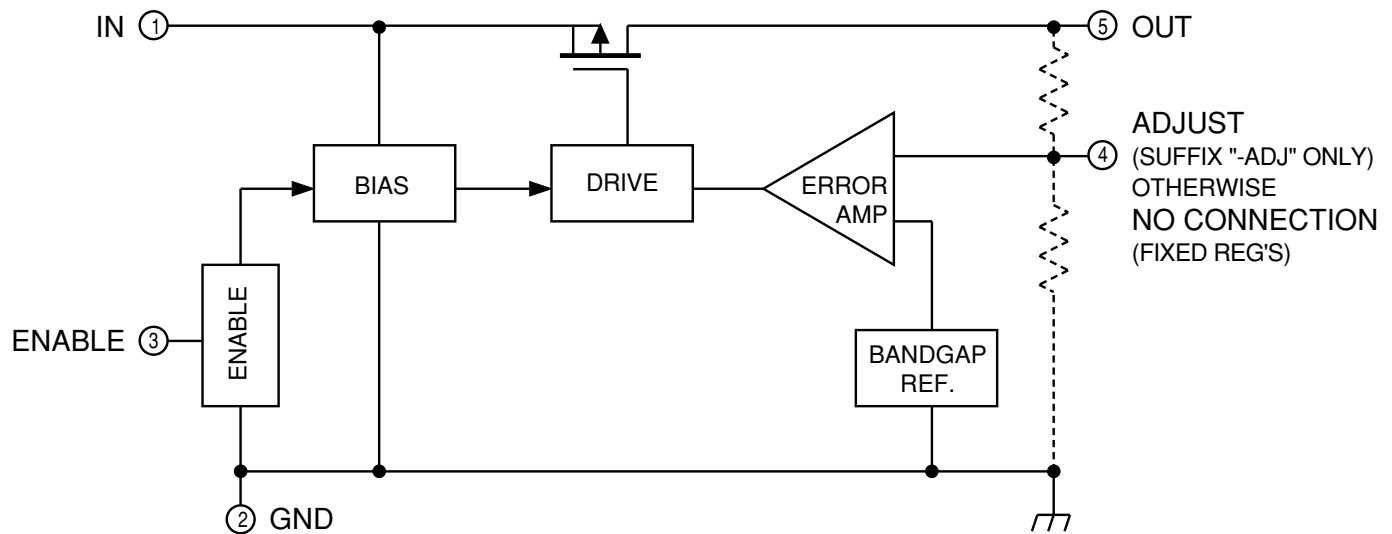

A8205SLH Maximum Allowable Average Output Current* with device mounted on 2.24" x 2.24" (56.9 mm x 56.9 mm) solder-coated copper-clad board in still air.

T _A	Allowable Total Average (10 ms) Output Current in Milliamperes with T _J = 150°C, Duty Cycle = 100%†								
	V _I - V _O								
	0.5	1.0	1.5	2.0	2.5	3.0	3.5	4.0*	4.5*
25°C	200	200	200	200	200	189	162	142	126
50°C	200	200	200	200	182	152	130	114	101
70°C	200	200	200	182	145	121	104	91	81
85°C	200	200	197	148	118	98	84	74	66

* Absolute maximum peak output current rating is 200 mA; absolute maximum input voltage is 7 V.

† $I_O = (T_J - T_A) / ([V_I - V_O] R_{\theta JA} \times dc) = (150 - T_A) / ([V_I - V_O] \times 220 \times 1.00)$

Output current rating can be increased (to 200 mA maximum) by additional heat sinking or reducing the duty cycle.

8205 LOW-DROPOUT REGULATORS

ELECTRICAL CHARACTERISTICS at $T_A = +25^\circ\text{C}$, $V_E = V_I$ (unless otherwise noted).

Characteristic	Symbol	Test Conditions	Limits			
			Min.	Typ.	Max.	Units
Output Voltage	V_O	$V_I \geq V_{O(\text{nom})} + 1\text{ V}$, $1\text{ mA} \leq I_O \leq 150\text{ mA}^*$, reference specified $V_{O(\text{nom})}$	—	0.0	± 1.5	%
Output Volt. Temp. Coeff.	a_{VO}	$V_I = 6\text{ V}$, $I_O = 10\text{ mA}$, $T_J \leq 125^\circ\text{C}$	—	40	—	ppm/ $^\circ\text{C}$
Line Regulation	$\Delta V_{O(\Delta V_I)}$	$V_{O(\text{nom})} + 1\text{ V} \leq V_I \leq 7\text{ V}$, $I_O = 3\text{ mA}$	—	—	± 1.5	%
Load Regulation	$\Delta V_{O(\Delta I_O)}$	$V_I = V_{O(\text{nom})} + 1\text{ V}$, $1\text{ mA} \leq I_O \leq 150\text{ mA}^*$	—	—	± 1.5	%
		$V_I = 7\text{ V}$, $1\text{ mA} \leq I_O \leq 150\text{ mA}^*$	—	—	± 1.5	%
Dropout Voltage	$V_{I\text{min}} - V_O$	$I_O = 100\text{ mA}$	—	75	200	mV
Ground Terminal Current	I_{GND}	$V_I = V_{O(\text{nom})} + 1\text{ V}$, $I_O = 1\text{ mA}$	—	55	65	μA
		$V_I = V_{O(\text{nom})} + 1\text{ V}$, $I_O = 150\text{ mA}^*$	—	55	65	μA
		$V_I = 7\text{ V}$, $I_O = 1\text{ mA}$	—	55	65	μA
		$V_I = 7\text{ V}$, $I_O = 150\text{ mA}^*$	—	55	65	μA
	I_Q	$V_I \leq 7\text{ V}$, $V_E \leq 0.8\text{ V}$, $I_O = 0\text{ mA}$	—	—	1.0	μA
ENABLE Input Voltage	V_{EH}	$V_I \geq V_{O(\text{nom})} + 1\text{ V}$, Output ON	2.0	—	—	V
	V_{EL}	$V_I \geq V_{O(\text{nom})} + 1\text{ V}$, Output OFF	—	—	0.4	V
ENABLE Input Current	I_E	$V_E = V_I = 7\text{ V}$	—	—	± 1.0	μA
Internal Reference Voltage	V_{REF}		—	1.26	—	V
ADJUST Input Current	I_{ADJ}	A8205SLH-ADJ only	—	0.10	—	μA
Rejection Ratio	PSRR	$V_I = V_{O(\text{nom})} + 1.5\text{ V}$, $V_i = 100\text{ mV}$, $I_O = 30\text{ mA}$, $f = 60\text{ Hz}$	—	70	—	dB
Output Noise	e_n	$10\text{ Hz} \leq f \leq 100\text{ kHz}$, $I_O = 10\text{ mA}$, $C_O = 10\text{ }\mu\text{F}$	—	0.5	—	$\mu\text{V}/\sqrt{\text{Hz}}$

Typical values are at $T_A = +25^\circ\text{C}$ and are given for circuit design information only.

* Pulse test ($\leq 20\text{ ms}$). See previous page for duty cycle limitations.

8205

LOW-DROPOUT REGULATORS

APPLICATIONS INFORMATION

Linear regulators require input and output capacitors in order to maintain over-all loop stability. The recommended minimum value for the input capacitor is 0.1 μF . The output capacitor is the dominant pole that provides the high-frequency compensation required for over-all regulator loop stability. These devices are stable with as little as 1 μF . However, to ensure stable operation under all conditions and capacitor types, the recommended minimum value is 4.7 μF . The output capacitor may be partially distributed through the load circuits. However, at least 1 μF should be connected at the regulator using the shortest and widest foil pattern possible.

The A8205SLH-ADJ requires an external voltage divider to set up the desired regulated output voltage between 2.0 V and 6.8 V ($V_1 \leq 7$ V). The two resistors are chosen such that

$$V_O = 1.26 (R_1 + R_2)/R_2.$$

The resistor values are usually as high as possible to maintain high circuit efficiency, but R2 should be less than 300 k Ω .

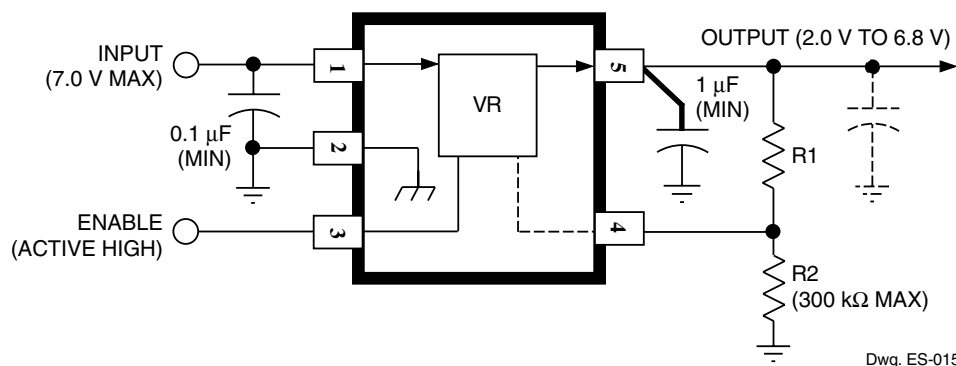

Thermal Considerations

These devices are intended to provide more than 150 mA of continuous current in a very small package. The table on page 2 of this data sheet gives the maximum allowable average output current for a worst-case printed circuit design ($R_{\theta JA} = 220^\circ\text{C}/\text{W}$ with a minimum footprint). Performance improvement is easily accomplished with the addition of 1 square inch of copper at terminal 2 ($R_{\theta JA} = 170^\circ\text{C}/\text{W}$).

8205
LOW-DROPOUT
REGULATORS

THIS PAGE INTENTIONALLY LEFT BLANK

8205
LOW-DROPOUT
REGULATORS

THIS PAGE INTENTIONALLY LEFT BLANK

8205 LOW-DROPOUT REGULATORS

Dimensions in Inches (for reference only)

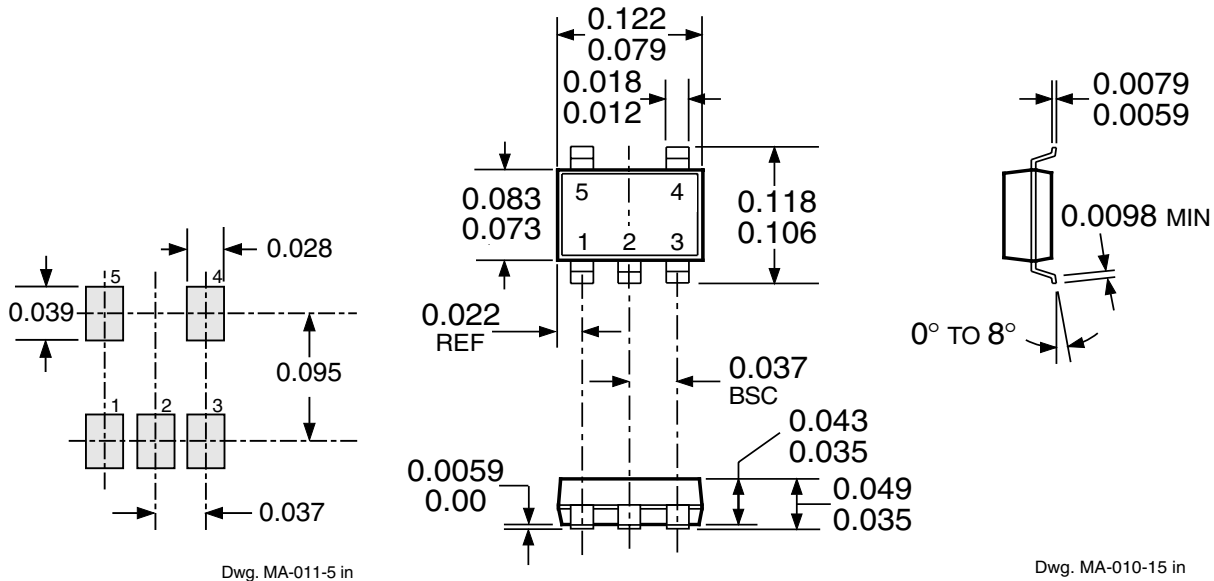

Dimensions in Millimeters (controlling dimensions)

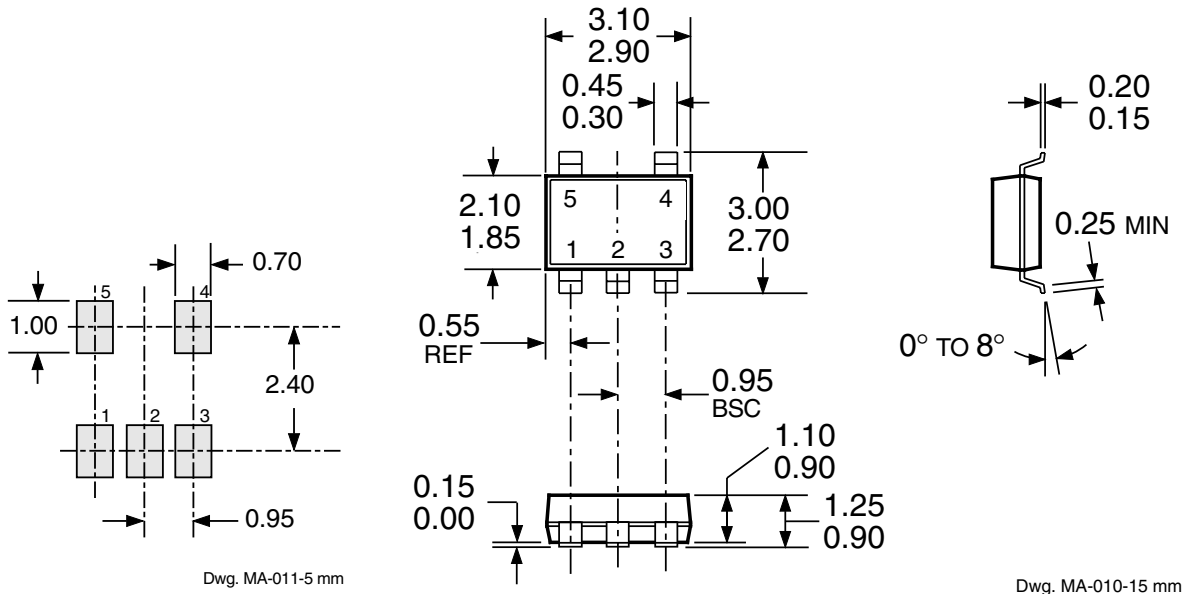

- NOTES:
1. Tolerances on package height and width represent allowable mold offsets. Dimensions given are measured at the widest point (parting line).
 2. Exact body and lead configuration at vendor's option within limits shown.
 3. Height does not include mold gate flash.
 4. Where no tolerance is specified, dimension is nominal.

8205
LOW-DROPOUT
REGULATORS

The products described here are manufactured under one or more U.S. patents or U.S. patents pending.

Allegro MicroSystems, Inc. reserves the right to make, from time to time, such departures from the detail specifications as may be required to permit improvements in the performance, reliability, or manufacturability of its products. Before placing an order, the user is cautioned to verify that the information being relied upon is current.

Allegro products are not authorized for use as critical components in life-support devices or systems without express written approval.

The information included herein is believed to be accurate and reliable. However, Allegro MicroSystems, Inc. assumes no responsibility for its use; nor for any infringement of patents or other rights of third parties which may result from its use.