



IPAD™

STPAC01F2

RF DETECTOR FOR POWER AMPLIFIER CONTROL

MAIN PRODUCT CHARACTERISTICS

The STPAC01F2 has two outputs, one for the signal detection and another one for the temperature compensation:

- $V_{DCout} = 0.88\text{ V}$ at 0.85 GHz at 10 dBm
- $V_{DCout} = 1.07\text{ V}$ at 1.85 GHz at 10 dBm
- $V_{supply} = 5\text{ V max}$
- Lead free package

DESCRIPTION

The STPAC01F2 is an integrated RF detector for the power control stage. It converts RF signal coming from the coupler into a DC signal usable by the digital stage. It is based on the use of two similar diodes, one providing the signal detection while the second one is used to provide a temperature information to thermal compensation stage. A biasing stage suppresses the detection diode drop voltage effect.

Target applications are cellular phones and PDA using GSM, DCS, PCS, AMPS, TDMA, CDMA and 800 MHz to 1900 MHz frequency ranges.

BENEFITS

- The use of IPAD technology allows the RF front-end designer to save PCB area and to drastically suppress parasitic inductances.

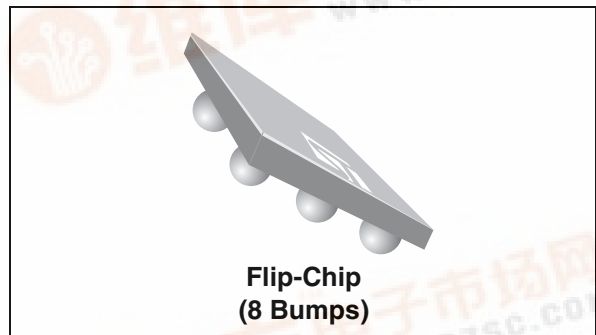

Table 1: Order Code

Part Number	Marking
STPAC01F2	RA

Figure 1: Pin Configuration (Ball side)

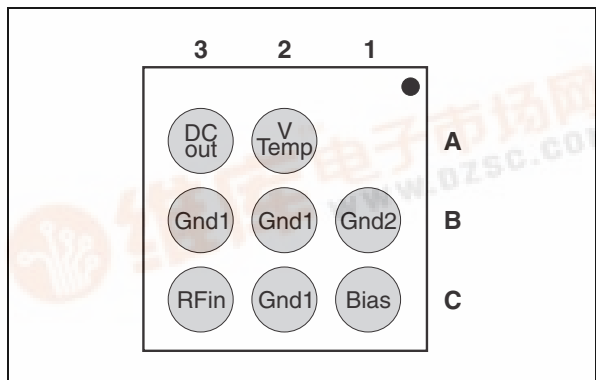
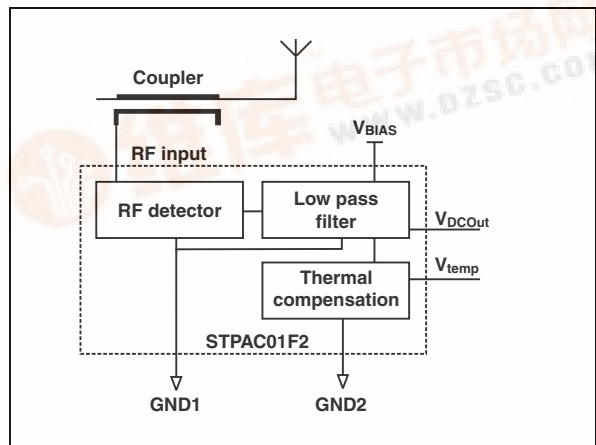

Figure 2: Functional diagram



STPAC01F2

Table 2: Absolute Retings ($T_{amb} = 25^{\circ}\text{C}$)

Symbol	Parameter and test conditions	Value	Unit
V_{BIAS}	Bias voltage	5	V
P_{RF}	RF power at the RF input	20	dBm
F_{OP}	Operating frequency range	0.8 to 2	GHz
V_{PP}	ESD level as per MIL-STD 883E method 3015.7 notice 8 (HBM)	250	V
T_{OP}	Operating temperature range	- 30 to + 85	$^{\circ}\text{C}$
T_{STG}	Storage temperature range	- 55 to + 150	$^{\circ}\text{C}$

ELECTRICAL CHARACTERISTICS ($T_{amb} = 25^{\circ}\text{C}$)

Table 3: Parameters related to BIAS voltage

Symbol	Parameter	Test conditions	Min.	Typ.	Max.	Unit
V_{BIAS}	Operating bias voltage		2.2		3.2	V
I_{BIAS}	Bias current	$V_{BIAS} = 3.2\text{ V}$			0.5	mA

Table 4: Parameters related detection function ($V_{BIAS} + 2.7\text{ V}$, DC output load = 100k Ω)

Symbol	Parameter	Test conditions	Min.	Typ.	Max.	Unit
V_{DCout}	DC output voltage (see fig. 1, $I_{DC} = 50\ \mu\text{A}$)	$F = 1.85\text{ GHz}$, $P_{RF} = 10\text{ dBm}$	0.97	1.07	1.17	V
		$F = 1.85\text{ GHz}$, $P_{RF} = -20\text{ dBm}$	1.83	1.93	2.03	
		$F = 0.85\text{ GHz}$, $P_{RF} = 10\text{ dBm}$	0.78	0.88	0.98	
		$F = 0.85\text{ GHz}$, $P_{RF} = -20\text{ dBm}$	1.83	1.93	2.03	
ΔV_{DCout}	DC output voltage variation (see fig. 8, $I_{DC} = 50\ \mu\text{A}$)	$0 < T_{amb} < 70^{\circ}\text{C}$ $F = 1.85\text{ GHz}$, $P_{RF} = 10\text{ dBm}$		0.09		V
		$2.2 < V_{BIAS} < 3.2\text{ V}$ $F = 1.85\text{ GHz}$, $P_{RF} = 10\text{ dBm}$		0.44		

Table 5: Parameters related to detection function

Symbol	Parameter	Test conditions	Min.	Typ.	Max.	Unit
V_{Temp}	Temperature output voltage (see fig. 9)	$I_{DC} = 50\ \mu\text{A}$	1.83	1.93	2.03	V
ΔV_{Temp}	Temperature output voltage variation (see fig. 9)	$I_{DC} = 50\ \mu\text{A}$, $0 < T_{amb} < 70^{\circ}\text{C}$		0.09		V
		$I_{DC} = 50\ \mu\text{A}$, $2.2 < V_{BIAS} < 3.2\text{ V}$		0.44		



Figure 3: Application diagram

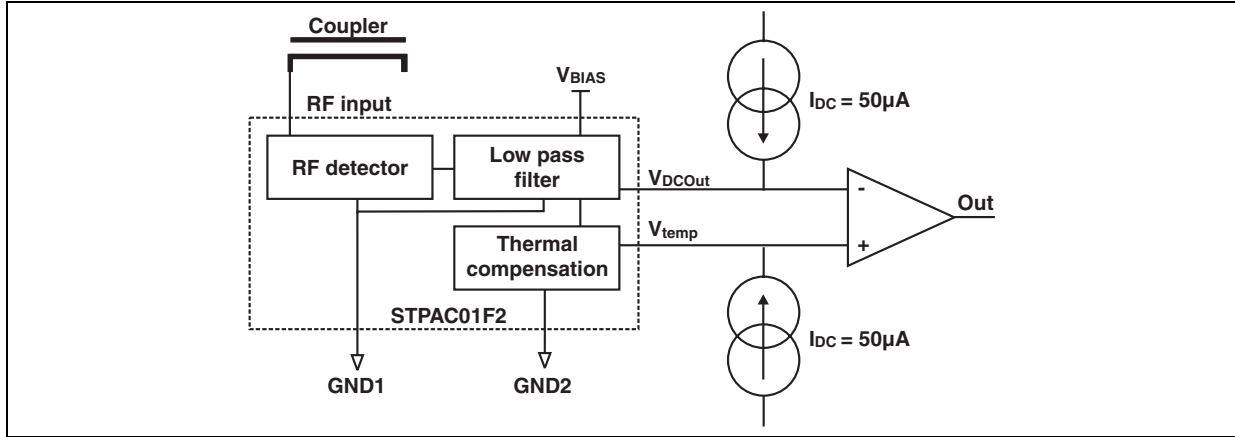

The STPAC01 is the first part of the power amplifier stage and provides both RF power and die temperature measurements. The above figure gives the basic circuit of RF detector.

A coupler located on the line between RF amplifier output and the antenna takes a part of the available power and applies it to STPAC01 RF input.

The RF detector and the low pass filter provide a DC voltage depending on the input power. Thermal compensation provides a DC voltage depending on the ambient temperature. As the detection system and the thermal compensation are based on the same topology, VDCout will have the same temperature variation as Vtemp. Connected to a differential amplifier, the output will be a voltage directly linked to the RF input power. VDCout and Vtemp must be bias with 50µA DC current.

This topology offers the most accurate output value as it is 100% compensated.

Figure 4: V_{DCout} measurement circuit

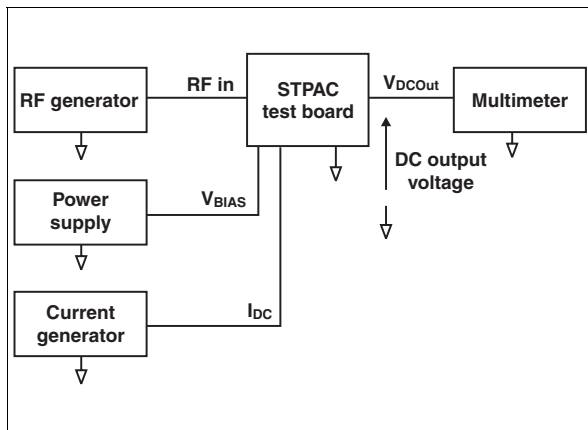

Figure 5: V_{DCout} versus RF input power

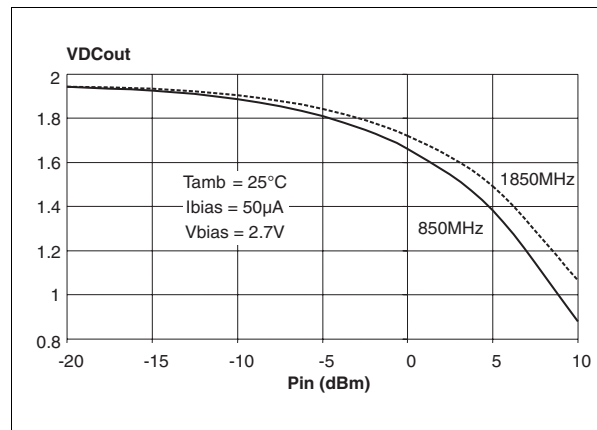

Figure 6: Relative variation of V_{DCout} versus frequency (from 800 to 900 MHz)

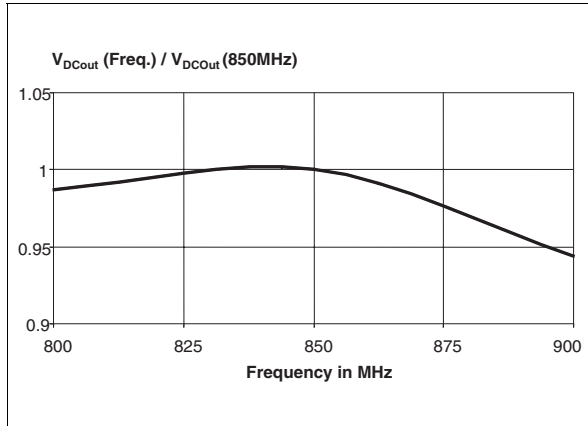

Figure 7: Relative variation of V_{DCout} versus frequency (from 1800 to 1900 MHz)

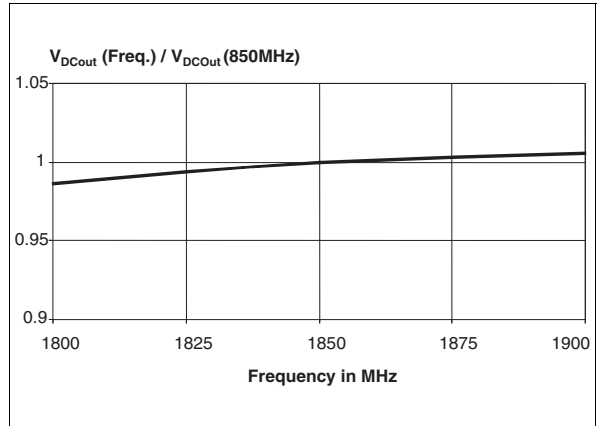

Figure 8: Temperature effect measurement circuit on V_{DCout}

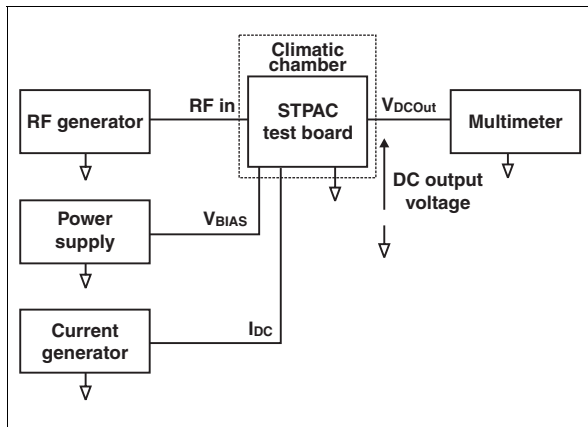

Figure 9: V_{temp} measurement circuit

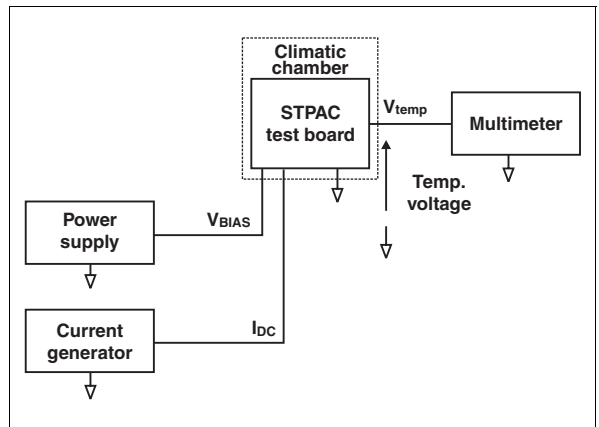

Figure 10: V_{temp} output voltage versus ambient temperature

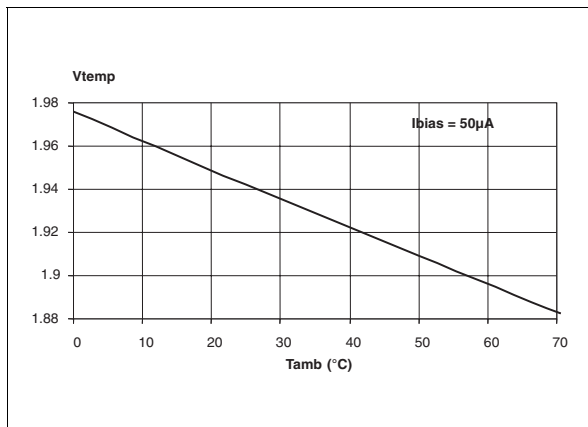

Figure 11: FLIP-CHIP Package Mechanical Data

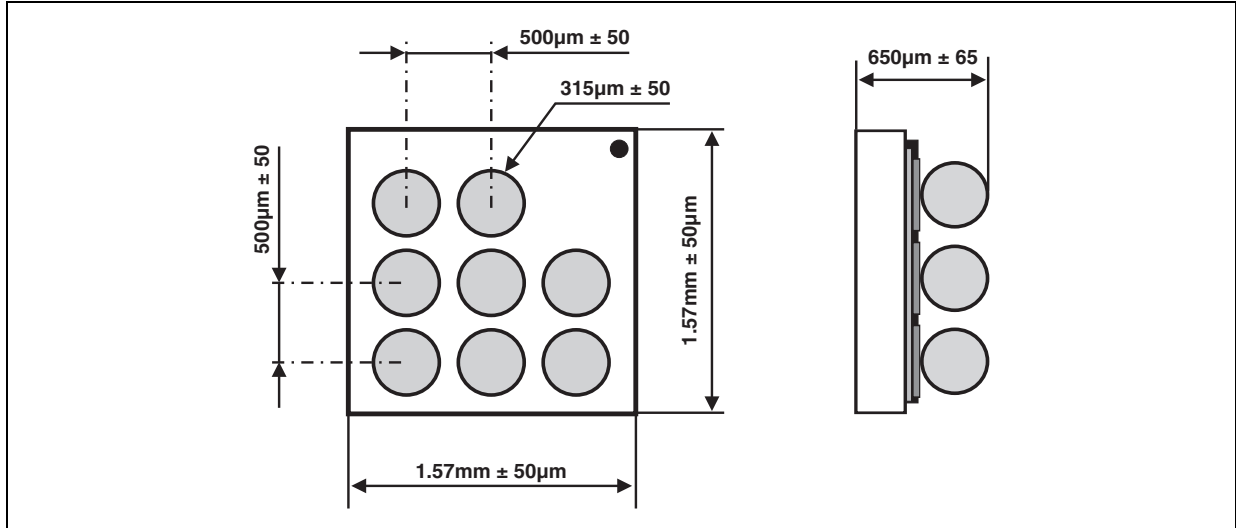

Figure 12: Foot print recommendations

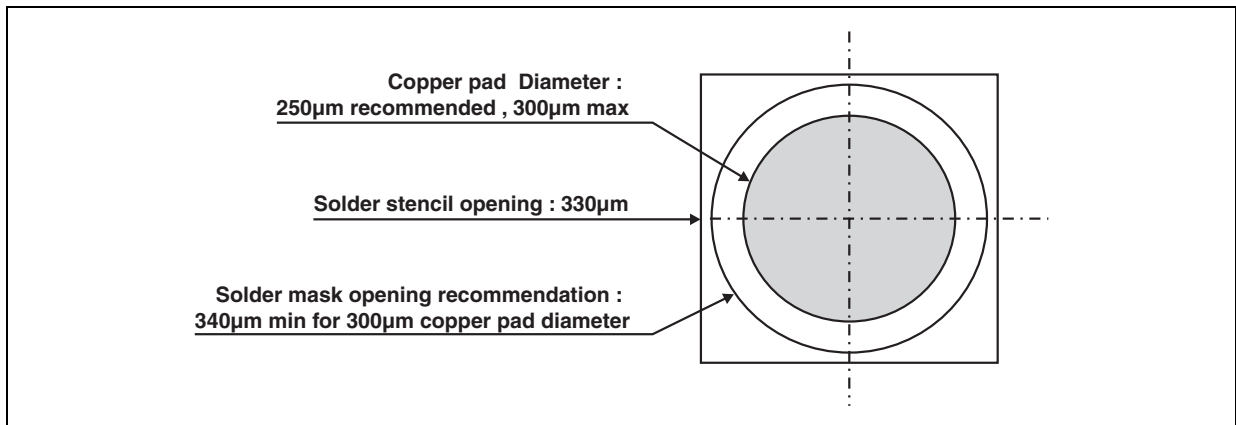
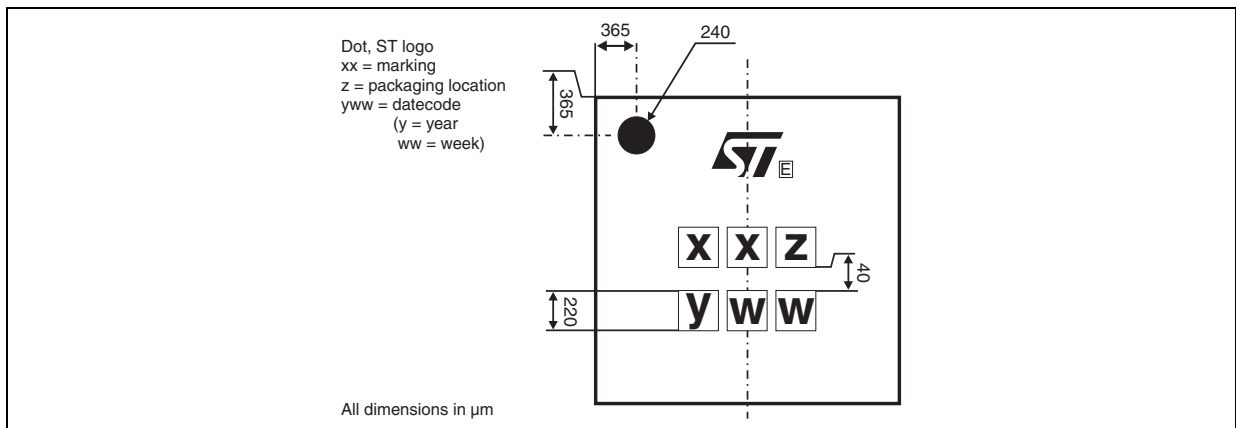

Figure 13: Marking



STPAC01F2

Figure 14: FLIP-CHIP Tape and Reel Specification

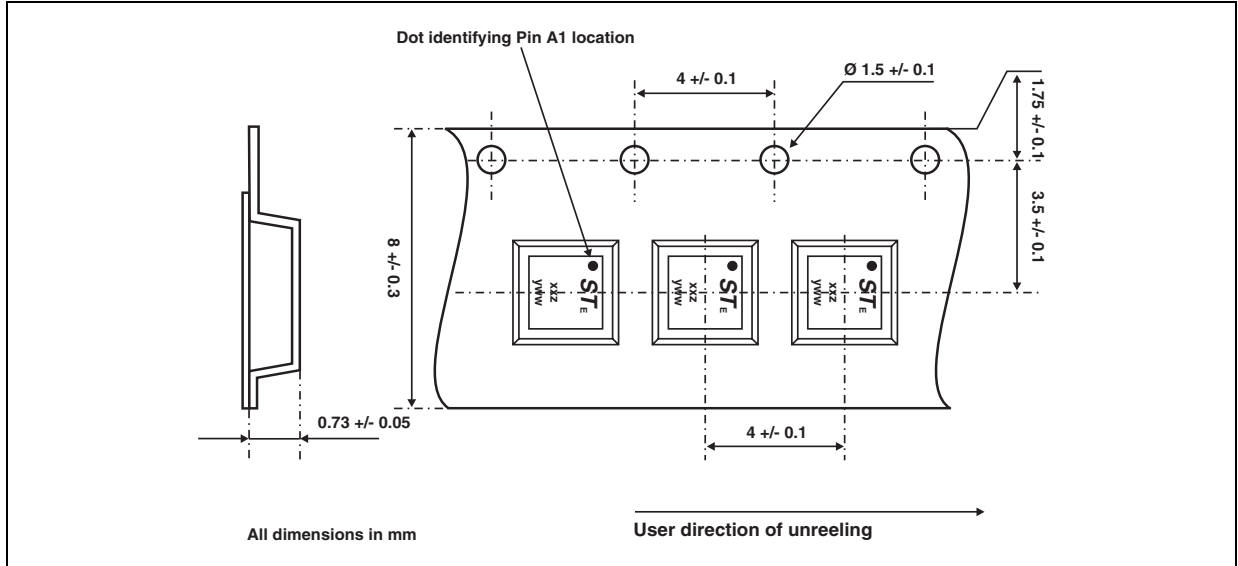

Table 6: Ordering Information

Ordering code	Marking	Package	Weight	Base qty	Delivery mode
STPAC01F2	RA	Flip-Chip	3.3 mg	5000	Tape & reel 7"

Note: More informations are available in the application notes:
 AN1235: "Flip-Chip: Package description and recommendations for use"
 AN1751: "EMI Filters: Recommendations and measurements"

Table 7: Revision History

Date	Revision	Description of Changes
21-Oct-2004	1	First issue



Information furnished is believed to be accurate and reliable. However, STMicroelectronics assumes no responsibility for the consequences of use of such information nor for any infringement of patents or other rights of third parties which may result from its use. No license is granted by implication or otherwise under any patent or patent rights of STMicroelectronics. Specifications mentioned in this publication are subject to change without notice. This publication supersedes and replaces all information previously supplied. STMicroelectronics products are not authorized for use as critical components in life support devices or systems without express written approval of STMicroelectronics.

The ST logo is a registered trademark of STMicroelectronics.
All other names are the property of their respective owners

© 2004 STMicroelectronics - All rights reserved

STMicroelectronics group of companies

Australia - Belgium - Brazil - Canada - China - Czech Republic - Finland - France - Germany - Hong Kong - India - Israel - Italy - Japan -
Malaysia - Malta - Morocco - Singapore - Spain - Sweden - Switzerland - United Kingdom - United States of America
www.st.com

