

Pressure Sensors Gage/Unamplified

130PC Series

Temperature Compensated Sensors

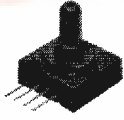

FEATURES

- Miniature package
- Can be used to measure with vacuum or positive pressure
- Absolute and gage sensors available
- Calibrated Null and Span
- Temperature compensated for Span over 0 to 50°C
- Provides interchangeability
- Lowest cost 1, 100 and 150 psi calibrated and temperature compensated sensor

136PC SERIES PERFORMANCE CHARACTERISTICS at 10.0 ±0.01 VDC Excitation, 25°C

	Min.	Typ.	Max.	Units
Excitation	---	10	16	VDC
Null Offset	-1	0	+1	mV
Null Shift, 25° to 0°, 25° to 50°C	---	±2.0	±4.0	mV
Sensitivity Shift, 25° to 0°, 25° to 50°C	---	±1.5	±3.0	%Span
Repeatability & Hysteresis	---	±0.15	---	%Span
Response Time	---	---	1.0	msec
Input Resistance	---	6.8 K	---	ohms
Output Resistance	---	4.0 K	---	ohms
Stability over One Year	---	±0.5	---	%Span
Weight	---	5	---	grams

ENVIRONMENTAL SPECIFICATIONS

Operating Temperature	-40° to +85°C (-40° to +185°F)
Storage Temperature	-55° to +125°C (-67° to +257°F)
Compensated Temperature	0° to +50°C (32° to +122°F)
Shock	MIL-STD-202, Method 213 (150 g, half sine, 11 msec)
Vibration	MIL-STD-202, Method 204 (10 to 2000 Hz at 20 g)
Media	P2 port Wetted materials: polyester housing, epoxy adhesive, silicon, borosilicate glass, and silicon-to-glass bond* P1 port Dry gases only

* Liquid media containing some highly ionic solutions could potentially neutralize the chip-to-glass tube bond.

136PC SERIES ORDER GUIDE

Catalog Listing	Pressure Range psi	Span mV			Sensitivity mV/psi Typ.	Overpressure psi Max.	Linearity, %Span	
		Min.	Typ.	Max.			P2 > P1 Typ.	P1 > P2 Typ.
136PC01G2	0-1	18.5	20	21.5	20	20	±1.0	±0.50
136PC05G2	0-5	48.5	50	51.5	10	20	±1.00	±0.50
136PC15G2	0-15	98.5	100	101.5	6.67	45	±1.00	±0.50
136PC15G2L	0-15 (L)	38.5	40	41.5	2.67	60	±0.50	±0.25
136PC15G2L	0-30 (0-15L)	75	79	83	2.63	60	±0.75	±0.50
136PC65G2	0-65	25.5	27.0	28.5	0.50	150	±1.00	---
136PC100G2	0-100	96	100	104	1.00	150	±0.40	---
136PC150G2	0-150	56	60	64	0.40	225	±0.40	---



Pressure Sensors Gage/Unamplified

130PC Series

ELECTRICAL CONNECTIONS

Voltage Excitation

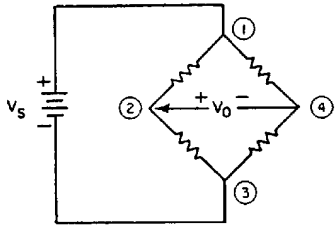

NOTES

1. Circled numbers refer to sensor termination.
2. V_0 changes with pressure difference.
3. $V_0 = V_2 - V_4$ (referenced to pin 3).
4. Current excitation provides reduced sensitivity variation with temperature.

INTERNAL CIRCUITRY

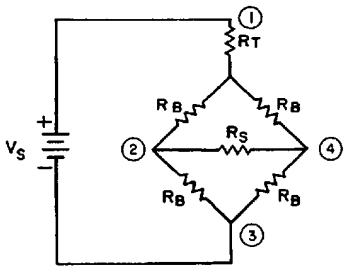

NOTES

1. Circled numbers refer to sensor termination.
2. $V_0 = V_2 - V_4$ (referenced to pin 3).
3. R_B = Strain gage resistors (~5.0 k Ω).
4. R_T = Sensitivity temperature compensation resistor.
5. R_S = Sensitivity calibration resistor.

When a positive pressure is applied to port P2, the differential voltage $V_2 - V_4$ (voltage at pin 2, with respect to ground, increases and voltage at pin 4 decreases) increases linearly with respect to the input pressure. When a vacuum pressure is pulled at port P2 (or positive pressure applied to port P1) the voltage $V_2 - V_4$ decreases linearly with respect to the input pressure.

Unamplified

SENSITIVITY SHIFT

The diagram at right illustrates how sensitivity shift relates to temperature. Note that the maximum shift occurs at temperature extremes. Therefore, if a sensor is not exposed to the entire temperature range, the maximum sensitivity shift will actually be less than the value specified.

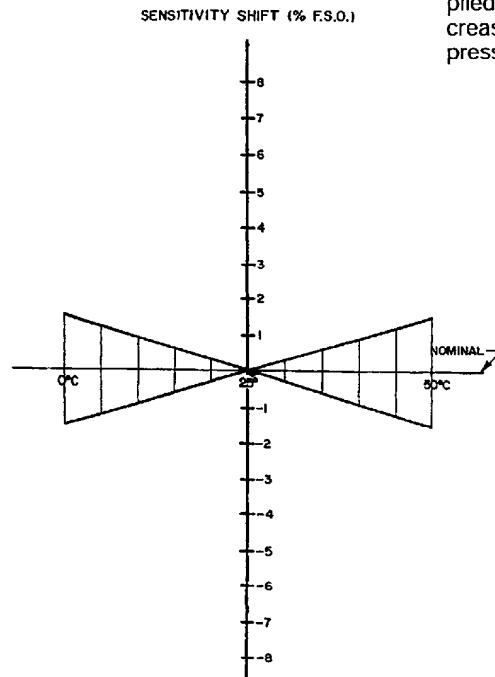

Pressure Sensors Gage/Unamplified

130PC Series

MOUNTING DIMENSIONS (For reference only)

Gage Types

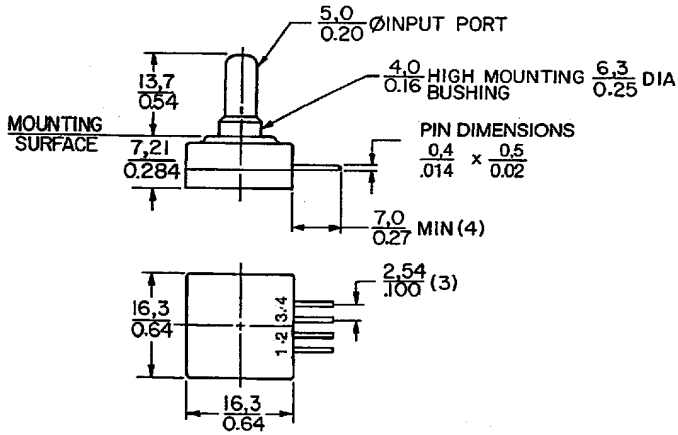
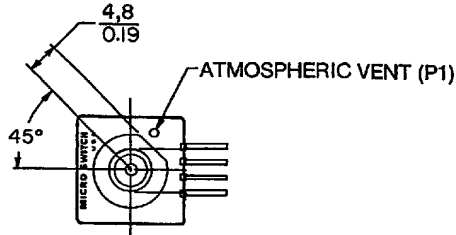

Terminals

- 1 - Vs (+)
- 2 - Output A
- 3 - Ground (-)
- 4 - Output B

Mounting Hardware

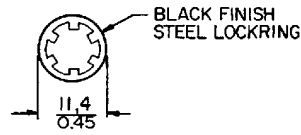

130PC CONSTRUCTION

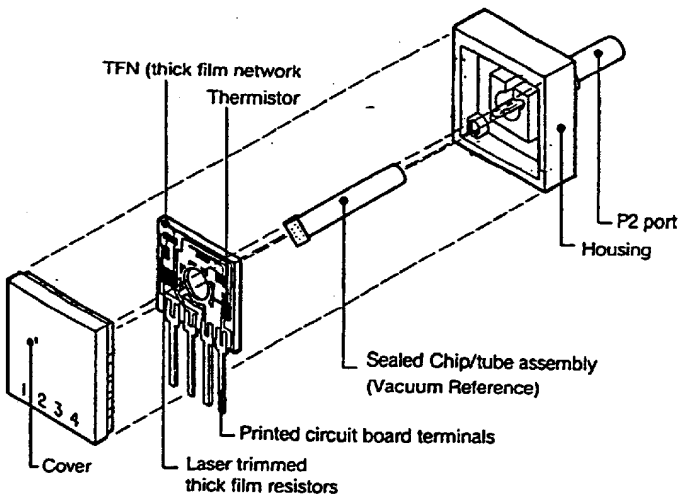

Pressure Sensors

Absolute/Unamplified

130PC Series

Temperature Compensated Sensors



FEATURES

- Miniature package
- Calibrated Null and Span
- Temperature compensated for Span over 0 to 50°C
- Provides interchangeability

136PC SERIES PERFORMANCE CHARACTERISTICS at 10.0 ±0.01 VDC Excitation, 25°C

	Min.	Typ.	Max.	Units
Excitation	---	10	16	VDC
Null Offset @ 0 psia	---	0	---	mV
Null Shift, 25° to 0°, 25° to 50°C	---	±2.0	±4.0	mV
Sensitivity Shift, 25° to 0°, 25° to 50°	---	±1.5	±3.0	%Span
Repeatability & Hysteresis	---	±0.15	---	%Span
Response Time	---	---	1.0	msec
Input Resistance	---	6.8 K	---	ohms
Output Resistance	---	4.0 K	---	ohms
Stability over One Year	---	±0.5	---	%Span
Weight	---	5	---	grams

ENVIRONMENTAL SPECIFICATIONS

Operating Temperature	-40° to +85°C (-40° to +185°F)
Storage Temperature	-55° to +125°C (-67° to +257°F)
Compensated Temperature	0° to +50°C (32° to +122°F)
Shock	MIL-STD-202, Method 213 (150 g, half sine, 11 msec)
Vibration	MIL-STD-202, Method 204 (10 to 2000 Hz at 20 g)
Media	P2 port Hermetically sealed vacuum reference. P1 port Dry gases only

Unamplified

136PC SERIES ORDER GUIDE

Catalog Listing	Pressure Range psia	2 psia Reference			Span mV			Sensitivity mV/psi Typ.	Overpressure psi Max.	Linearity, %Span Max.
		Min.	Typ.	Max.	Min.	Typ.	Max.			
136PC15A2	0-15	-14.43	-13.33	-12.23	-97.5	-100	-102.5	-6.67	45	±0.50
136PC15A2L	0-15 (L)	-6.43	-5.33	-4.23	-37.5	-40	-42.5	-2.67	60	±0.25
136PC15A2L	0-30 (0-15L)	-6.37	-5.27	-4.17	-74	-79	-84	-2.63	60	±0.50

Pressure Sensors

Absolute/Unamplified

130PC Series

ELECTRICAL CONNECTIONS

Voltage Excitation

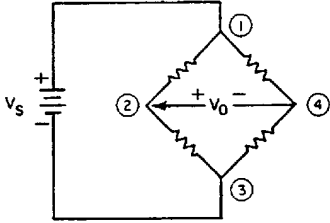

INTERNAL CIRCUITRY

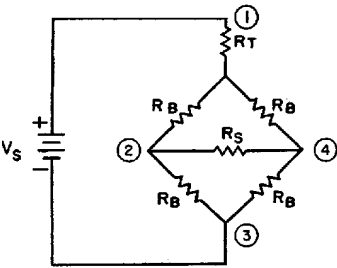

NOTES

1. Circled numbers refer to sensor termination.
2. V_O changes with pressure difference.
3. $V_O = V_2 - V_4$ (referenced to pin 3).
4. Current excitation provides reduced sensitivity variation with temperature.

NOTES

1. Circled numbers refer to sensor termination.
2. $V_O = V_2 - V_4$ (referenced to pin 3).
3. R_B = Strain gage resistors (~5.0 k Ω).
4. R_T = Sensitivity temperature compensation resistor.
5. R_S = Sensitivity calibration resistor.

When input pressure increases above 0 psia, voltage at pin 2 will decrease and voltage at pin 4 will increase with respect to ground (pin 3). This causes the output voltage, defined as the differential voltage $V_2 - V_4$, to decrease linearly (become more negative).

SENSITIVITY SHIFT

The diagram at right illustrates how sensitivity shift relates to temperature. Note that the maximum shift occurs at temperature extremes. Therefore, if a sensor is not exposed to the entire temperature range, the maximum sensitivity shift will actually be less than the value specified.

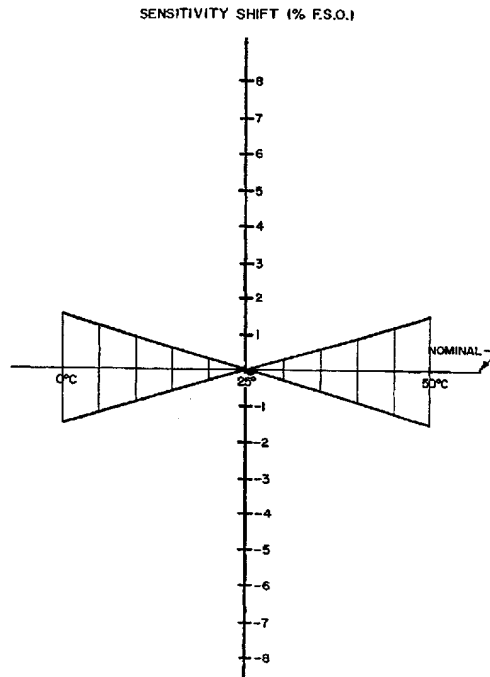

Pressure Sensors Absolute/Unamplified

130PC Series

MOUNTING DIMENSIONS (For reference only)

Absolute Types

- Terminals
 1 - Vs (+)
 2 - Output A
 3 - Ground (-)
 4 - Output B

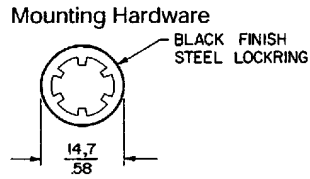
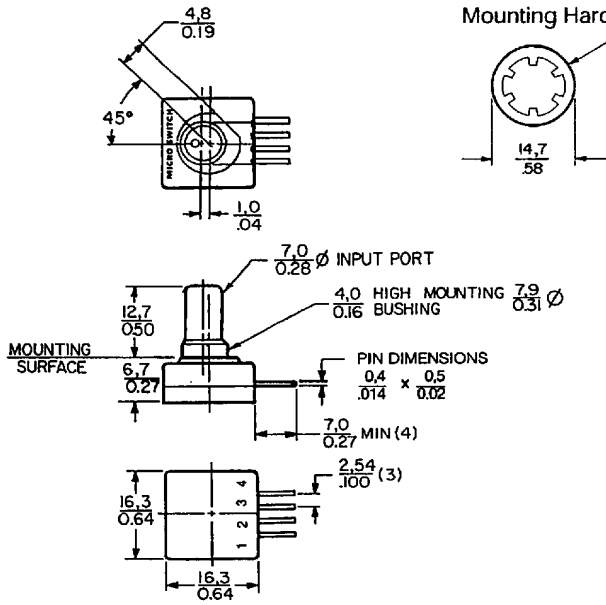

Unamplified

130PC CONSTRUCTION

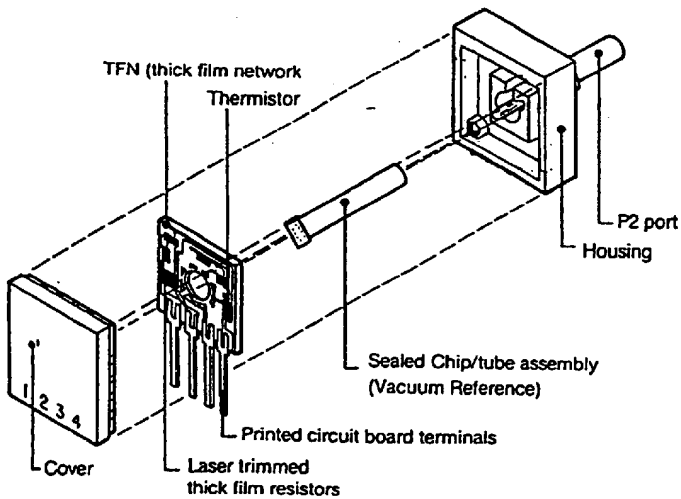

107642

4551830 0021619 T22