

PanelView Standard

Operator Interface Terminals



Allen-Bradley

Where Extraordinary Performance is the Standard

The Allen-Bradley PanelView Standard operator interface terminals are extraordinary performers in the real world of control system automation. You'll find them working hard around the world, supporting the automotive, food and beverage, pulp and paper, water and wastewater, and petrochemical industries. Each PanelView Standard terminal carries UL, cUL/CSA and CE certifications. They are rated for NEMA 4X (IP54, IP65) and approved for Class 1 Division 2 (flat-panel only) operation. These terminals are engineered for scalability, reliability, and compatibility for lower cost of ownership and improved productivity.

PanelView terminals exemplify Rockwell Automation's commitment to the highest standards of product dependability, technological innovation, and performance, and backed with the highest levels of customer service and support in the industry.

For a complete operator interface solution designed for rugged performance in a standalone or network environment, PanelView Standard is an extraordinary choice.



PanelView Standard Terminal Features

- Over 140 terminal combinations to fit any operator interface application
- 14 display combinations, from 3.0" flat panel to 14" CRT, in color, grayscale, or monochrome, each designed for minimal installation depth with maximum viewing angles
- Keypad, Touch Screen, or Keypad/Touch Screen combinations for convenient and flexible operator input
- RS-232 Printer Port to print alarms, alarm lists, triggered messages and triggered states of a multi-state indicator
- ATA PC Flash Memory Cards for fast application downloads, convenient storage of Universal Language Support fonts, and simplified firmware upgrades
- Field Replaceable Backlights to extend screen life of PanelView 550, 600, 900 and 1000 (color) terminals
- 100,000 hour LED backlight for PanelView 300 and 300 Micro



PanelView 300 – 1400 terminals
support ATA Memory Card usage.



High Performance Functions

Advanced Alarm Capabilities

PanelView terminals can record and display important data on triggered alarms using an alarm list. With an alarm banner, operators and maintenance personnel are notified immediately to fault conditions.



Alarm banner alerts operators to fault conditions



Alarm Lists record and display important alarm data

Screen Security

Restrict access to application screens to authorized operators. Up to 16 passwords per application can be used to secure individual screens, allow access to configuration mode, and allow entry from screen saver or idle mode. Three screen security modes are available:

- **screen mode** – prompts user for password when entering a secured screen
- **login mode** – operator can move between any unsecured and secured screen for which the login password is valid
- **auto login mode** – same as login mode, but login and logout keys are not required

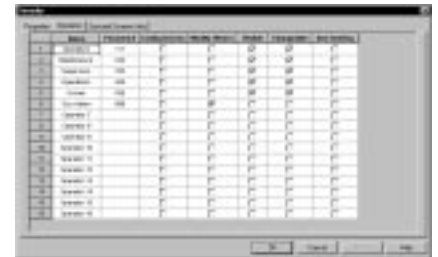

Local Language Support

PanelView terminals can display application screens in over 46 languages. Use the built-in extended ASCII character set for languages such as French, Italian, German, and Spanish. Or with an external font file, stored on an installed ATA memory card, display languages or other fonts supported by Windows.

PanelView terminals now support up to 5 languages in a single application. Switch between English, French, Italian, German, and Spanish text while in run mode, without using an external ATA memory card.



PanelBuilder32 development software can be used to configure application screens with text in over 46 languages



PanelView Standard Communications

- **EtherNet/IP** – connects and communicates with a PLC-5E, SLC 5/05, ENI module, and Logix 5000 controllers over the 1756 Ethernet bridge
- **ControlNet Terminal** – certified ControlNet International compliant, communicates to multiple controllers on a ControlNet network, supporting scheduled and unscheduled PLC-5 and ControlLogix messages, and redundant cabling
- **DeviceNet Terminal** – certified DeviceNet compliant, connects and communicates at a device level on a DeviceNet link (125k, 250k or 500k baud) using server explicit, client explicit, I/O or 'Listen Only' messaging
- **Data Highway Plus Terminal** – communicates to single or multiple PLC, SLC 5/04, and ControlLogix controllers over an Allen-Bradley DH+ network
- **Remote I/O Terminal** – communicates to a PLC, SLC or ControlLogix system, supporting both discrete and block transferring of data
- **DH-485 Terminal** – communicates to single or multiple SLC or MicroLogix controllers on a DH-485 network
- **RS-232 (DH-485 protocol) Terminal** – communicates point-to-point to a MicroLogix or SLC controller as a dedicated connection for high priority data, as well as the AIC+ module for DH-485 network communication
- **RS-232 (DF1 protocol) Terminal** – communicates to a single SLC, PLC-5, or MicroLogix controller over a point-to-point DF1 link
- **Profibus Terminal** – uses Profibus DP standard protocol for high-speed (up to 1.5M) data transmission to Siemens® and other controllers
- **Modbus Terminal** – uses half duplex, master-slave protocol to communicate over non-Rockwell Automation control architectures including Modicon and GE® controllers

PanelView with EtherNet/IP

The Allen-Bradley PanelView Standard operator interface family now offers EtherNet/IP

networking capability with real-time control, device configuration, diagnostic information and multi-vendor interoperability. Available on the PanelView 550, 550T, 600, 600T, 900, 1000, and 1400, customers can now realize a tighter communication between manufacturing and corporate operations as well as cost-effective plant-wide communication.

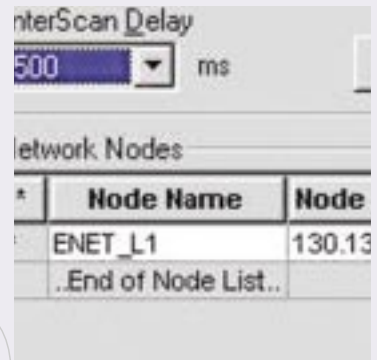

PanelView EtherNet/IP Communications

PanelView with EtherNet/IP will support:

- PLC-5E
- SLC 5/05
- ControlLogix processor
- EtherNet/IP interfaces such as the PLC-5 EtherNet/IP expansion module (1785-ENET)
- EtherNet/IP interface module (ENI module 1761-NET-ENI)
- Other EtherNet/IP devices.

EtherNet/IP PanelView network addresses can be DHCP/BootP, DNS, or manually configured.

PanelView with EtherNet/IP provides users with:

- Open EtherNet/IP protocol
- Messaging services and I/O control
- RJ-45 media connector for 10/100 Mbps twisted pair
- 10/100 auto negotiation.

PanelView with EtherNet/IP, as a result, supplies every service that is essential in control and device-level networks.



PanelBuilder32 Software

For quick and easy screen configuration

PanelBuilder32 software supports the entire family of PanelView Standard terminals, allowing easy conversion and reuse of existing applications. Designed to operate on Microsoft Windows (including Windows 2000) operating system, PanelBuilder32 features an intuitive development environment to simplify application design, reduce development time, maximize performance, and improve productivity.

- **Full complement of operator devices including push buttons, selectors, numeric and ASCII entry devices, diagnostic indicators, message displays, embedded numeric and ASCII variable displays, custom graphics and more**
- **Popup alarm messages for instant notification**
- **Analog gauges offer an intuitive display method of numeric values**
- **Cut, copy, paste, and tag import/export capabilities in and between various PanelView application files for additional time saving advantages**
- **Multiple application files open at same time**
- **Extensive ControlLogix support including 32-bit data types, backplane addressing, and native symbolic addressing**
- **Support of up to 5 languages in a single application through the text editor function**
- **Remote device configuration for application file upload/download over Local Area Networks (LAN) using RSLinx and ControlLogix Gateway**
- **Import/export capability for the RSLogix software family of programming software for Rockwell Automation Logic Controllers. Create control tags once and export to RSLogix for use in the Logic Controller program**
- **Extensive compatibility with Microsoft Office tools including Excel where control tags can be created and edited and then imported into PanelBuilder32 and RSLogix Logic Controller packages. Use Microsoft tools to create, sort and organize your control tags**
- **Copyable .PDF documentation, Screen Print as well as development screen capture tools for the speedy creation of OEM specific manuals and documentation**
- **Operator interface support for all of Rockwell Automation Logic controllers and networks**
- **Open, re-use and save legacy PanelView Standard applications. Maintains the value in your PanelView investment**
- **Data Tips show the control behind the object. Tool tips remind you of tool functions**



PanelBuilder32 Software is used to configure all PanelView Standard terminals



PanelView32 applications can easily migrate between terminals



PanelView 300 Micro

The PanelView 300 Micro operator interface terminal is the newest addition to the PanelView Standard family. Just 5.2" x 4.4" and only 1.4" installed depth, this compact terminal is ideal for customers who need a space-saving and low-cost yet feature-rich solution. It is designed for low-end graphical or text only operator interface applications, and includes many of the same hardware features found in the PanelView Standard family.

- **3" diagonal transfective LCD (LED back-lit) monochrome graphic display, ideal for high ambient light applications**
- **100,000 hour LED backlight life**
- **128x64 pixel resolution**
- **4 function keys and configurable cursor keys**
- **1.4" (35mm) installed depth**
- **Power 11 – 30V dc**
- **DF1 or DH-485 (RS-232) communication via 8-pin mini-DIN port**



PanelView 300 Keypad

The PanelView 300 Keypad operator interface terminal is a popular OEM choice.

Designed for low-end graphical or text only operator interface applications, this terminal is faithful to the features found on PanelView Standard terminals. The LCD monochrome graphic display and feature-rich design allow for high-performance in applications that demand a compact, less expensive interface.

- **3" diagonal transfective LCD (LED back-lit) monochrome graphic display, ideal for high ambient light applications**
- **100,000 hour LED backlight life**
- **128x64 pixel resolution**
- **8 relegendable function keys, numeric keypad, cursor control keys**
- **2.7" (69mm) installed depth**
- **Power 18–32V dc**
- **DeviceNet, DF1, and DH-485 (RS-232) communication options**

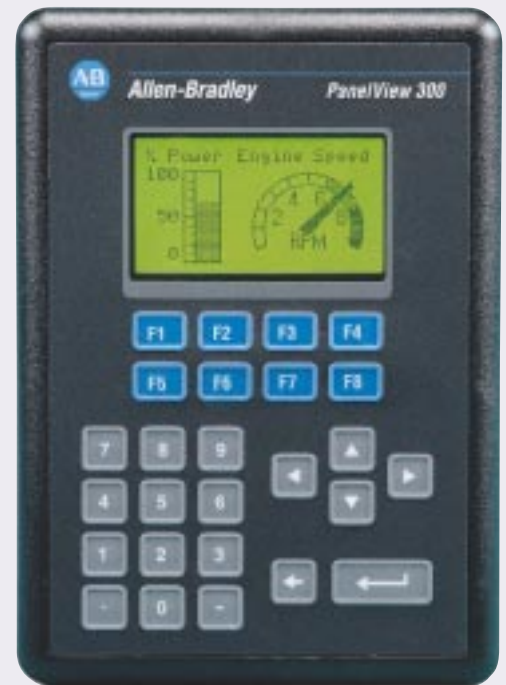

PanelView 550

Keypad, Keypad/Touch, Touch-Only

These PanelView 550 Keypad, Keypad/Touch and Touch-only pixel-graphic display terminals are cost-effective ways for end-users and OEMs to incorporate high performance operator interface devices into applications or machines where panel space is limited. These terminals have a minimum installed depth and flat panel

designed to lower the cost of ownership. PanelView

- **5.5" diagonal LCD monochrome display**
- **256x128 pixel resolution**
- **10 relegendable function keys, numeric keypad, cursor control keys**
- **128 touch cells (combo terminal only)**
- **3.4" (86mm) installed depth**
- **Power 85-264V ac or 18-32V dc**



PanelView 600

Keypad, Keypad/Touch, Touch-Only

The PanelView 600 Keypad, Keypad/Touch, and Touch-only terminals are high performance color terminals for applications where color graphic displays are required and panel space is limited.

- **6.0" diagonal TFT active matrix color display**
- **320x234 pixel resolution**
- **10 relegendable function keys, numeric keypad, cursor control keys**
- **Power 85-264V ac or 18-32V dc**



PanelView 1000

Color Keypad or Touch Grayscale Keypad or Touch

The PanelView 1000 is Rockwell Automation's original entry in the "medium size, color, flat panel" operator interface segment. Its flat panel color or grayscale display, modest installed depth, operator input capabilities, alarm functions, and communication options have made it a popular workhorse in the growing operator interface market.

Today, the PanelView 1000 shares the same comprehensive features found throughout the Allen-Bradley PanelView Standard family. Choose between keypad or touch screen input with either color or grayscale display, and nine different communication options. All are ready to network with the Allen-Bradley family of controllers as well as other PLC brands.

These terminals have the same robust PanelView Standard hardware characteristics for installation in a wide range of environments and industrial applications.



- **Color version: 10.4" diagonal TFT active matrix color display; VGA 640x480 pixel resolution**
- **Grayscale version: 10.4" diagonal electro-luminescent (EL) display; 640x480 pixel resolution**
- **Keypad version: 16 relegendable function keys, numeric keypad, cursor control keys**
- **Touch screen version: 384 touch cells**
- **3.5" (90mm) installed depth**
- **Power 85-264V ac or 18-32V dc**

PanelView 1400

Keypad or Touch

The PanelView 1400 is Rockwell Automation's largest color display operator interface terminal. The maximum display angle, multiple operator input capabilities, sophisticated alarm functions, and communication options make it a popular workhorse in a variety of industrial control applications.

- **14" diagonal CRT color display**
- **SVGA 800x600 pixel resolution**
- **Keypad version: 21 relegendable function keys, numeric keypad, cursor control keys**
- **Touch screen version: 384 touch cells**
- **14.7" (370mm) installed depth**
- **Power 85-264V ac**



PanelView 300 Micro

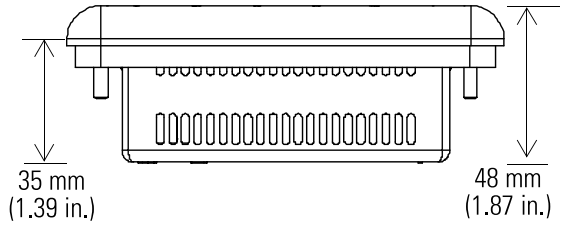
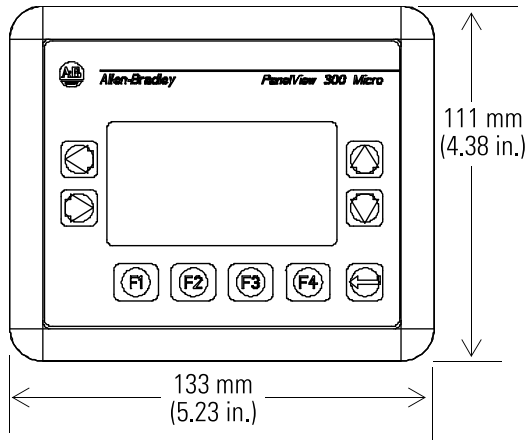

PanelView 300 Keypad

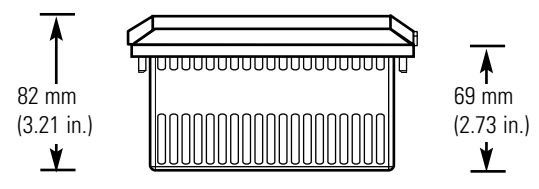
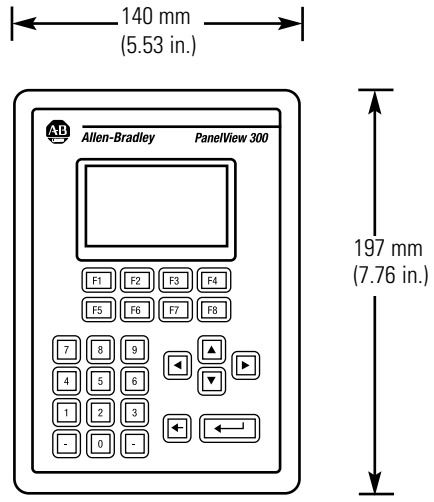

PanelView 550

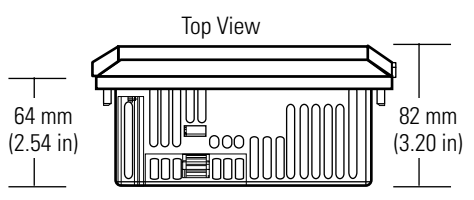
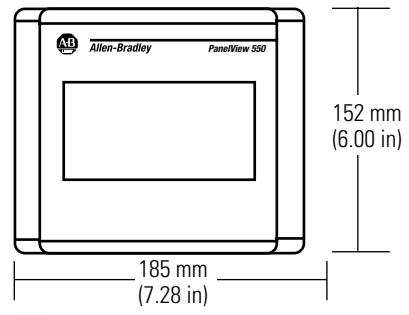
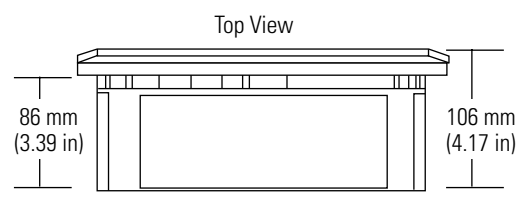
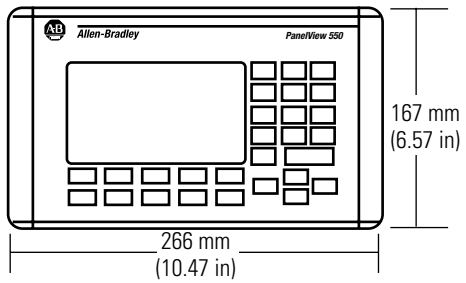

PanelView 600

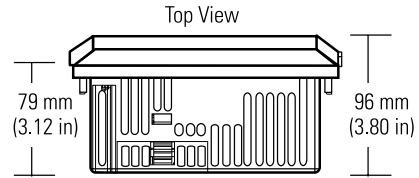
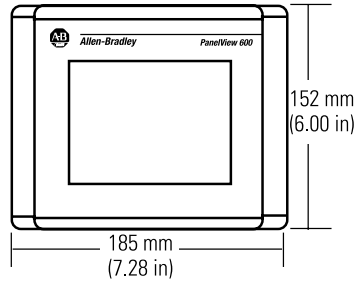
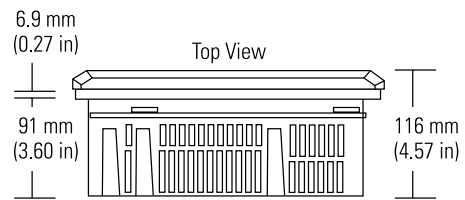
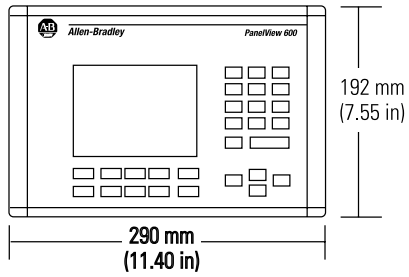

PanelView 1000

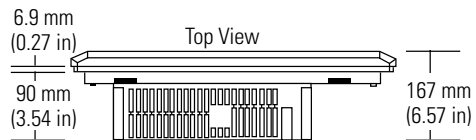
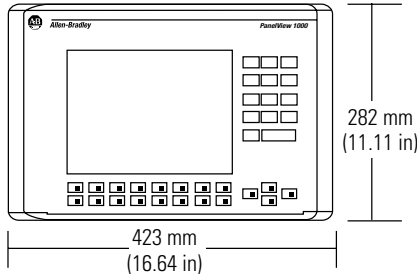
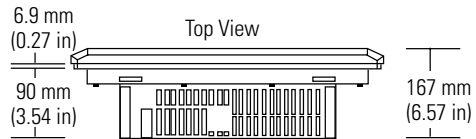
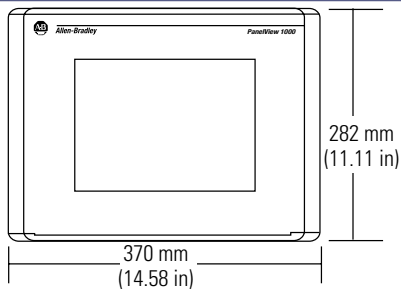

PanelView 1400

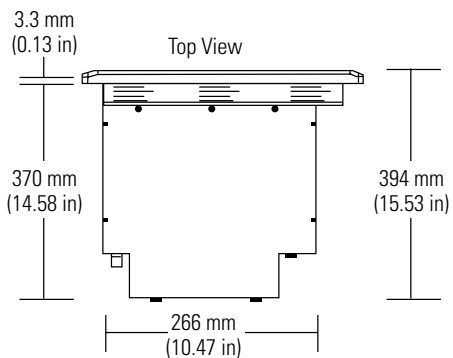
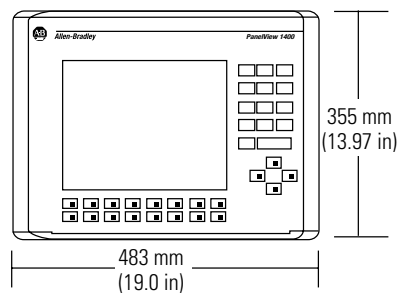
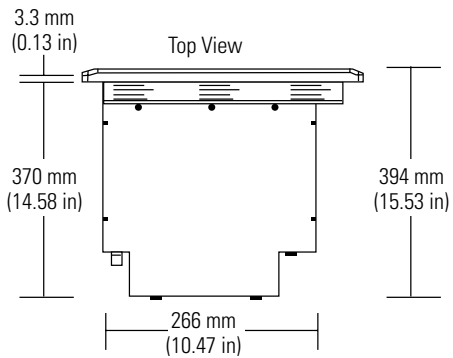
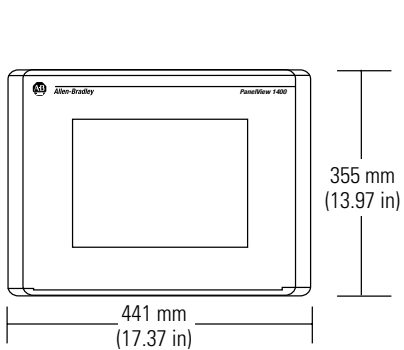

PanelView Standard Selection Guide *(See Catalog Number section for ordering)*

PanelView 300 Micro

PanelView 300

PanelView 550

PanelView 550T

PanelView 600



D I S P L A Y					
Type	Monochrome transfective LCD with integral LED backlight		Monochrome Liquid Crystal Display (LCD)		Color Active Matrix Thin Film Transistor (TFT)
Size:	2.87" x 1.67" (73mm x 42mm)		4.75" x 2.38" (120mm x 60mm)		4.54" x 3.4" (115mm x 86mm)
Replaceable Backlight	N/A –100,000 hour LED backlight life		Field replaceable backlight		
Operator Input	Keypad	Keypad	Keypad or Combination Keypad and Touchscreen	Touchscreen Only	Keypad or Combination Keypad and Touchscreen
Touch Cells	N/A	N/A	128	128	128
Function Keys	4 (F1 - F4) 4 Nav/Function Keys	8 (F1 - F8)	10 (F1 - F10)	N/A	10 (F1 - F10)
Real time Clock	Battery-backed clock timestamps critical data				
Application Memory	170K application runtime; 240K Flash (application objects + text + bitmaps)				190K application runtime; 240K Flash (application objects + text + bitmaps)
E L E C T R I C A L					
Communication Port	RS-232 (DH-485 protocol), DF1, 8-pin Mini DIN connector	DeviceNet, DH-485, RS-232 (DH-485 protocol), DF1	EtherNet/IP, DeviceNet, ControlNet, DH+, Remote I/O, DH-485, RS-232 (DH-485 protocol), DF1, Profibus (1.5Mb), Modbus		
RS-232 Printer Port	N/A	1200, 2400, 9600, 19200 baud rate			
Power Requirements	AC: N/A DC: 11-30 Vdc	AC: N/A DC: 18-32 Vdc	AC: 85-264 Vac DC: 18-32 Vdc	AC: N/A DC: 18-32 Vdc	AC: 85-264 Vac DC: 18-32 Vdc
Power Consumption	AC: N/A DC: 2.5 Watts max. (0.105A@24 Vdc)	AC: N/A DC: 10 Watts max. (0.42A@24 Vdc)	AC: 45 VA max. DC: 18 Watts max. (0.75A@24 Vdc)	AC: N/A DC: 18 Watts max. (0.75A@24 Vdc)	AC: 60 VA max. DC: 34 Watts max. (1.9A@24 Vdc)
Programming	PanelBuilder32 (Windows based)				
E N V I R O N M E N T A L					
Operating Temperature	0 to 55°C (32 to 131°F)				
Storage Temperature	-20 to 85°C (-4 to 188°F)	-25 to 70°C (-13 to 158°F)	-20 to 70°C (-4 to 158°F)		-25 to 70°C (-13 to 158°F)
Humidity	5 to 95%, noncondensing @ 0 to 55°C	5 to 95%, noncondensing @ 0 to 30°C			5 to 95%, noncondensing @ 0 to 55°C
Ratings	NEMA Type 12, 13, 4x (indoor only), IP54, IP65				
Certifications	UL, cUL approved; Class 1 Div 2 Groups A,B,C,D; CE marked	UL, cUL approved; Class I, Div 2 Groups A, B, C, D; CE marked, Demko	UL, cUL approved; Class 1, Div 2 Groups A, B, C, D; CE marked	UL, cUL approved; Class 1, Div 2 Groups A, B, C, D; CE marked	UL, cUL approved; Class 1, Div 2 Groups A, B, C, D; CE marked, Demko
W E I G H T					
Keypad	10 oz. (284 g)	1.484 lbs. (673 g)	2.7 lbs (1.2 kg)	N/A	4.4 lbs (2 kg)
Touch Screen	N/A	N/A	N/A	2.1 lbs. (0.93kg)	N/A
D I M E N S I O N S					
Keypad	4.38" (h) x 5.23" (w) x 1.87" (d) (111mm x 133mm x 48mm)	7.76" (h) x 5.51" (w) x 3.21" (d) (197mm x 140mm x 82mm)	6.6" (h) x 10.5" (w) x 4.2" (d) (167.6mm x 266.7mm x 106.7mm)	N/A	7.55"(h) x 11.40"(w) x 4.57"(d) (192mm x 290mm x 116mm)
	N/A	N/A	6.6"(h) x 10.5"(w) x 4.2"(d) (167.6mm x 266.7mm x 106.7mm)	5.92" (h) x 7.21" (w) x 3.2" (d) (150mm x 183mm x 81mm)	7.55"(h) x 11.40"(w) x 4.57"(d) (192mm x 290mm x 116mm)

PanelView 600T

PanelView 1000 Color

**PanelView 1000
Grayscale**

PanelView 1400

			
Color Passive Matrix	Color Active Matrix Thin Film Transistor (TFT)	Electroluminescent (EL)	Color CRT (SVGA)
4.54" x 3.43" (115mm x 87mm)	8.3" x 6.2" (211mm x 158mm)		10.0" x 7.5" (255mm x 191mm)
Field replaceable backlight		N/A – emissive display	N/A
Touchscreen Only	Keypad or Touchscreen		
128	384	384	384
N/A	16 (F1 - F16)	16 (F1 - F16)	21 (F1 - F21)
Battery-backed clock timestamps critical data			
190K application runtime; 240K Flash (application objects + text + bitmaps)	310K application runtime; 1008K Flash (application objects + text + bitmaps)		
EtherNet/IP, DeviceNet, ControlNet, DH+, Remote I/O, DH-485, RS-232 (DH-485 protocol), DF1, Profibus (1.5Mb), Modbus			
1200, 2400, 9600, 19200 baud rate			
AC: N/A DC: 18-32 Vdc	AC: 85-264 Vac DC: 18-32 Vdc	AC: 85-264 Vac DC: 18-32 Vdc	AC: 85-264 Vac DC: N/A
AC: N/A DC: 17 Watts max. (0.71A@24 Vdc)	AC: 70 VA max. DC: 27 Watts max. (1.1A@24 Vdc)	AC: 100 VA max. DC: 40 Watts max. (1.74A@24 Vdc)	AC: 200 VA max. DC: N/A
PanelBuilder32 (Windows based)			
0 to 50°C (32 to 122°F)	0 to 55°C (32 to 131°F)		
-25 to 70°C (-13 to 158°F)			-40 to 85°C (-40 to 185°F)
5 to 95%, non-condensing @ 0 to 40°C	5 to 95%, noncondensing @ 0 to 55°C		
NEMA Type 12, 13, 4x (indoor only), IP54, IP65			
UL, cUL approved; Class I, Div 2 Groups A, B, C, D; CE marked	UL, cUL approved; Class 1, Div 2 Groups A, B, C, D; CE marked, Demko	UL, cUL approved; Class 1, Div 2 Groups A, B, C, D; CE marked, Demko	UL, cUL approved; CE marked
N/A	8.2 lbs (3.7 kg)	7.2 lbs (3.3 kg)	44.75 lbs. (20.3 kg)
2.3 lbs. (1 kg)	7.9 lbs (3.6 kg)	7.0 lbs (3.2 kg)	43.2 lbs. (19.6 kg)
N/A	11" (h) x 17"(w) x 5" (d) (282mm x 423mm x 112mm)	11" (h) x 17" (w) x 5" (d) (282mm x 423mm x 112mm)	13.97" (h) x 19.0" (w) x 15.53" (d) (355mm x 483mm x 394mm)
N/A	11" (h) x 15" (w) x 5" (d) (282mm x 370mm x 112mm)	11"(h) x 15"(w) x 5"(d) (282mm x 370mm x 112mm)	13.97"(h) x 17.37"(w) x 15.53"(d) (355mm x 441mm x 394mm)



PanelView Standard Network Connections

Because PanelView Standard terminals offer such flexible communication options, you can optimize your operator interface needs to your control or process architecture. Or, as your control system needs change, so can your operator interface system.

Along with flexible network connections for runtime operation, you have multiple options for uploading and downloading application files with PanelBuilder32 – direct, over the network, or via a ‘Pass Through’ or ‘Gateway’ connection. And don’t forget ATA memory cards for easy file transfers.

Standard Network Connections – Runtime Operation

Network Connection	MicroLogix	SLC-500, 5/01, 5/02	5/03	5/04	5/05	PLC-5	ControlLogix
Remote I/O	n/a	5/02 with 1747-SN	with 1747-SN	with 1747-SN	with 1747-SN	yes	with 1756-DHRIO**
DH+	n/a	n/a	n/a	yes	n/a	yes	with 1756-DHRIO**
DF1	with AIC+*	n/a	Ch. 0	Ch. 0	Ch. 0	Ch. 0	yes
DH-485 (RS485 physical connection)	with AIC+	yes	yes	with AIC+ to Ch. 0	with AIC+ to Ch. 0	n/a	n/a
DH-485 (RS232 physical connection)	with AIC+*	with AIC+	Ch. 0	Ch. 0	Ch. 0	n/a	n/a
DeviceNet	with 1761- NET DNI	5/02 with 1747-SDN	with 1747-SDN	with 1747-SDN	with 1747-SDN	with 1771-SDN	with 1756-DNB
ControlNet	n/a	n/a	no	no	no	PLC-5C	with 1756-CNB***
EtherNet/IP	with 1761-NET-ENI	n/a	n/a	n/a	yes	PLC-5E, 1785-ENET	with 1756-ENET

* For isolation purposes if not on the same power supply.

** Legacy mode. Example: address = N7:0

*** Symbolic (CIP) addressing. Example: address = Tank level

PanelView Application File Upload/Download Direct and Network Connections

PanelView Type	Direct Connection PC (with PanelBuilder32 to PanelView)	Network Connection PC (with PanelBuilder32 over Network)
EtherNet/IP	2711-NC13 (via RS-232 printer port)	Yes – via Ethernet Port
DeviceNet	2711-NC13 (via RS-232 printer port)	Yes – via PV DeviceNet port
ControlNet	2711-NC13 (via RS-232 printer port)	Yes – via PV ControlNet port
Data Highway Plus	2711-NC13 (via RS-232 printer port)	Yes – via PV DH+ port
Remote I/O	2711-NC13 (via RS-232 printer port)	N/A – use a Pass-Through connection
DH-485 (RS-485 port)	1747-PIC* or AIC+ module	Yes – via PV DH-485 port
DH-485 (RS-232 port)	2711-NC13 (via RS-232/DH485 port) or PV 300 Micro: 2711-CBL-PM05 or -PM10	Yes – via PV RS-232 (DH-485) port (select terminals only)
DF1	2711-NC13 (via RS-232 port) or 2711-NC13 (via RS-232 printer port – select terminals only) PV300 Micro: 2711-CBL-PM05 or -PM10	N/A – use a Pass-Through connection
Profibus	2711-NC13 (via RS-232 printer port)	N/A
Modbus	2711-NC13 (via RS-232 printer port)	N/A

* When connecting a personal computer to a PanelView terminal, using a PIC without a controller connected, you need a power supply (1747-NP1)

PanelView Application File Upload/Download Pass-Through & Gateway Connections

PC Network (PC to Controller)	Controller*/Gateway	PanelView Network (Controller to PanelView)
Ethernet	ControlLogix/Gateway	ControlNet, DeviceNet, RI/O, DH+
	PLC-5	DeviceNet, RI/O
	SLC 5/05	DeviceNet, RI/O, DH-485, DF1
ControlNet	ControlLogix/Gateway	DeviceNet, RI/O, DH+
	PLC-5	DeviceNet, RI/O
DH+	PLC-5	DeviceNet, RI/O
	SLC 5/04	DeviceNet, RI/O, DH-485, DF1
DH-485	SLC 5/03, 5/04 , 5/05	DeviceNet, RI/O
	SLC 5/04	DH+
DF1	ControlLogix/Gateway	ControlNet, DeviceNet, RI/O
	SLC 5/03, 5/04, 5/05	DeviceNet, RI/O
	SLC 5/04	DH+



PanelView 'e'

Operator Interface Terminals

Gather, display, and share information.

Do it efficiently.

No matter how complex, make it intuitive.

That's PanelView 'e'.

Designed with high performance HMI functionality for complex process and large-scale control applications, these operator interface terminal workhorses provide powerful data processing capabilities, enhanced graphic and functions, flexible operator interface options, and powerful configuration software.

Using PanelView 1200?

If you're a current PanelView 1200 user, we want to make sure you stay productive well into the future and leverage your current investment. We're ready to help you move your current application to a PanelView 1000e or a PanelView 1400e.

How?

By migrating your older PanelView (2711-TA1, -TC1, -KA1, -KC1) to the PanelView 'e' graphic terminals.

Why? – It's easy !

Yes, you can re-use your application files – no need to reprogram.

Yes, you can use existing panel cut-outs – no need to re-cut most openings. Adaptor plates are available.

Yes, your PLC program and RIO network functionality is maintained – no PLC or RIO network changes necessary.

What's the advantage?

You'll have a new terminal with full factory warranty, minimizing repair cycle costs and down time concerns.

You'll be prepared for the flexibility and scalability of Rockwell Automation's ViewAnyWare strategy – a full enterprise visualization strategy with a suite of monitoring and control solutions.

More functionality and features to enhance your application.



Allen-Bradley



PanelView 1000e



PanelView 1400e

High performance functionality for complex and demanding processes

- **Keypad or Touch Screen**
- **On-board Data Highway Plus and Remote I/O port (automatically configured during application download); factory or field installed ControlNet interface option**
- **Keypad version: 21 user definable function keys, numeric keypad, cursor control keys**
- **Touch Screen version: Analog resistive screen for flexible input object size and location; up to 192 touch cells defined as small as 40x40 pixels**
- **Keyboard port for external keyboard or barcode reader input**
- **Relay port for external annunciation to a light or siren**
- **Printer port for external HP LaserJet-compatible or Epson-compatible printer to printout alarm messages and screen images; Portrait/Landscape and 8.5"X11"/A4 paper printing supported**
- **Connect Allen-Bradley Dataliner™ message displays, through the printer port, for alarm and information messaging**
- **2Mb application memory; expandable to 15.75Mb with PC memory card**



PanelView 'e' Functions, Graphics, Hardware

Object Math and Logic Expressions

Apply Arithmetic (+, -, *, /), logical (and, or, xor, not), comparison (=, <>, <, >, <+, >=), and 'IF/Then/Else' operations to object display components and numeric

input object control tags to reduce PLC ladder logic and addressing and avoid redundant network data transfers.

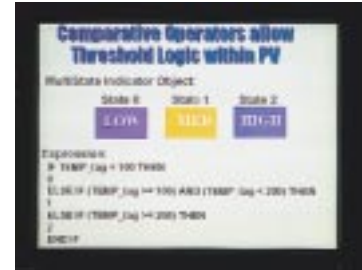

Trend Graphics

Use an 'Online Trend' graph object to display process variables over time on up to 4 line and/or symbol plots with sample rates from .25 to 84600 seconds.

Background screen plotting of up to 3000 data points and variable minimum and maximum values are supported.

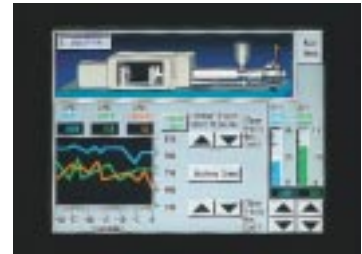

Alarming and Screen Security

Record and display important data on triggered alarms with three configurable alarm windows, alarm status screen and alarm history screen. Up to 4,000 alarm messages and 2,500 alarm history records

are supported. In addition, alarm history files can be uploaded to a PC for future reference. Also 10,000 local and 10,000 information messages provide more information to operators.

Restrict application screen access to up to 16 authorized operators using an access code entry pop-up window. A PLC controlled screen option directs operators to a specific screen through a PLC address assignment.

Graphic File Import

Import and resize both .bmp and .dxf graphic files using PanelBuilder 1400e for more accurate representation of machines and processes. Full color imports are

converted to the best 16 colors, from a 256 color pallet, for near photo quality imagery while minimizing memory usage.



Overlapping Screen Objects

Place control devices such as push buttons and indicators directly on top of other objects, like a machine layout

bitmap, for greater screen design flexibility and more intuitive operator control.



Hardware

- Keypad or touch screen terminals with flat panel or CRT displays offer convenient and flexible choices for operator input
- On-board Data Highway Plus and Remote I/O with optional ControlNet

- interface hardware either factory or field installed
- VGA and SVGA(1400e) color pixel graphics for flexibility in size and location of screen objects including overlapping for more intuitive operator control

- Expandable application memory up to 15.75M with PC memory card for extra large application or multiple applications on a single terminal. PC card can also be used for application file transfers and storage.



PanelView 'e' Selection Guide (See Catalog Number section for ordering)

PanelView 1000e

PanelView 1400e



D I S P L A Y		
Type	Color, Active Matrix, Thin Film Transistor (TFT)	Color CRT Display, Configurable VGA or SVGA
Size	10.4 inch (26.4 cm) diagonal	14 inch (35.5 cm) diagonal (nominal display size approx. 12" (30 cm))
Replaceable Backlight	Field Replaceable Backlight	N/A
Operator Input	Keypad or Touchscreen	
Touch Cells	Up to 192 (analog resistive)	
Function Keys	21 (F1 - F21)	
Real Time Clock	Battery-backed clock timestamps critical data	
Application Memory	2.25 Mb On-Board Flash; expandable to 15.75 Mb with external PC memory card	
Programming	PanelBuilder 1400e (Windows-based)	
E L E C T R I C A L		
Communication Port	ControlNet, DH+, Remote I/O	
RS-232 Printer Port	1200, 2400, 9600, 19200 baud rate	
Power Requirements	AC: 90-132 or 180-264 Vac, DC: N/A	
Power Consumption	60VA typical, 90VA max 45W typical, 70W max	180VA typical, 240VA maximum 75W typical, 100W maximum CRT degauss on powerup 5.5 Amps @ 115V for 400 ms 11 Amps @ 240V for 400 ms
E N V I R O N M E N T A L		
Operating Temperature	0 to 50°C (32 to 122°F)	
Storage Temperature	-25 to 60°C (-13 to 140°F)	-40 to 85°C (-40 to 185°F)
Humidity Rating	95% Humidity (noncondensing) @ 50°C (122°F)	95% Humidity (noncondensing) @ 30°C (86°F)
Ratings	NEMA Type 12 (Indoor Use Only), 4X, IP66 (Indoor Use Only)	NEMA Type 12 (Indoor Use Only), 4X, IP65 (Indoor Use Only)
Certifications	UL 50, 1992, ENCL 4X,12 (Indoor Use Only) CSA C22-2 No. 94-M91, ENCL 4X, 12 (Indoor Use Only)	
W E I G H T		
Keypad	11.6 lbs (5.3 kg)	40.1 lbs (18.2 kg)
Touch Screen	11.3 lbs (5.1 kg)	38.7 lbs (17.6 kg)
D I M E N S I O N S		
Keypad	11.1" (H) x 16.6" (W) x 6.8" (D) (282 mm x 423 mm x 174 mm)	14" (H) x 19" (W) x 16.7" (D) (355 mm x 483 mm x 424 mm)
Touch Screen	11.1" (H) x 14.6" (W) x 6.8" (D) (282 mm x 370 mm x 174 mm)	14" (H) x 17.4" (W) x 16.7" (D) (355 mm x 442 mm x 424 mm)



Network Connections – Runtime Operation

Network Connection	SLC-5/02	SLC 5/03	SLC 5/04	SLC 5/05	PLC-5	ControlLogix
Remote I/O	With 1747-SN	With 1747-SN	With 1747-SN	With 1747-SN	yes	With 1756-DHRIO**
DH+	n/a	n/a	yes	n/a	yes	With 1756-DHRIO**
ControlNet	n/a	n/a	n/a	n/a	PLC-5C	With 1756-CNB**

** Legacy Mode (PLC Mapping I.e. N7:0), Unscheduled messaging only

PanelView 'e' Application File Upload/Download Direct and Network Connections

PanelView 'e' Type	Direct Connection PC (with PanelBuilder 1400e) to PanelView 'e'	Network Connection PC (with PanelBuilder 1400e) over Network
ControlNet	2711-NC13 (via RS-232 printer port)	Yes – via PVe ControlNet port
Data Highway Plus	2711-NC13 (via RS-232 printer port)	Yes – via PVe DH+ port
Remote I/O	2711-NC13 (via RS-232 printer port)	N/A – Use a pass-through connection

PanelView 'e' Application File Upload/Download Pass-Through & Gateway Connections

PC Network (PC to Controller)	Controller*/Gateway	PanelView 'e' Network (Controller to PanelView 'e')
Ethernet	ControlLogix/Gateway	ControlNet, RI/O
	PLC-5	RI/O
	SLC 5/05	RI/O
ControlNet	ControlLogix/Gateway	RI/O
	PLC-5	RI/O
DH+	PLC-5	RI/O
	SLC 5/04	RI/O
DF1	SLC 5/03, 5/04, 5/05	RI/O
	SLC 5/04	DH+

*The controller must support PC network as well as PanelView 'e' network. Consult controller manual for details.

PanelView 'e' Network Connections

PanelView 'e' terminals are designed to provide superior HMI performance in large process or multiple controller applications, while optimizing network communications. These feature rich operator terminals offer standard connectivity to PLC-5®, SLC, and ControlLogix systems through ControlNet, Data Highway Plus, and Remote I/O network connections.

Upload and download application files with PanelBuilder 1400e software – direct, over the network, or via a 'Pass Through' or 'Gateway' connection.



MobileView™ Portable HMI

The Allen-Bradley MobileView Portable HMI family of operator interface devices are designed to address the diverse needs for flexibility in communication on the factory floor – flexibility that allows users to put the interface where it is needed. These portable devices are ideal for applications such as an operator panel for machines and plants, teach and program robots, test, maintenance and start up procedures.



MobileView Machine Terminal MT750

The MobileView Machine Terminal interface is a cabled, industrially hardened, Windows CE platform, designed for real-time machine interface. The mobility and integrated architecture work to reduce total lower cost of ownership through faster set-up and changeover times.

The MT750 uses a high-performance Intel StrongARM processor and provides an Ethernet interface. This terminal is ergonomically designed for either left- or right-handed use. It is constructed with a double shell, designed to survive bumps and drops, as well as provide protection against harsh environments. Functionality is easily expanded using PC cards Type I, II, and III. The MT750 easily adapts to specific applications using configurable operating and control elements.



MobileView Guard G750

The MobileView Machine Terminal G750 interface is a cabled, industrially hardened, Windows CE platform, designed for real-time machine interface and workplace safety. The mobility, integrated architecture and safety features work to reduce total lower cost of ownership through faster set-up and changeover times.

The G750 has the same features as the MT750 with added features that make it ideal for safety applications. The on-board emergency stop pushbuttons and three-position enable switches give users the mobility to access applications in gated or safety critical areas.

MobileView Tablet T750

The MobileView Tablet T750 is a wireless, industrially hardened, Windows CE platform that allows users to move uncabled around a product line or plant. The mobility and integrated architecture allows users to be in touch with their process wherever they are.

The T750 is a rugged, wireless Windows CE platform tablet that allows users to move uncabled around a product line or plant. The 7.7 inch VGA boasts 256 colors with input via analog resistive touch screen, programmable keys and navigation keys. It has an 802.11b, 2.4GHz link and comes preloaded with applications to support thin-client architectures. The T750 has a long-lasting lithium battery, a wireless thin client connection, and weighs less than four pounds. The tablet is designed to survive the plant

Constructed of tough magnesium alloy rubber border.



MobileView Specifications

	Machine Terminal MT750	Guard G750	Tablet T750
Processor	Intel StrongARM-SA-1110/206MHz		Hitachi SH-4 RISC (SH-7750)
Operating System	Microsoft Windows CE		
Memory	16MB DRAMB 32MB Flash or 64MB DRAM/64MB Flash (model dependent)		32MB Flash, 32MB SDRAM, 32MB RAM Backup and File Storage
Keypad	Stainless steel dome membrane switches with tactile feedback; F1-F12 Function keys, Numeric keys, Navigation keys, On-Screen Keyboard		Configurable navigation keys and four configurable one touch application program keys; On-Screen Keyboard
Operator Input/ Output Options	Handwheel, potentiometer, keyswitch, normally open pushbuttons with LEDs, IrDA keyboard/printer interface, and PC Card interface	Safety enable switches and E-stop; Handwheel, potentiometer, keyswitch, normally open pushbuttons with LEDs, IrDA keyboard/printer interface, and PC Card interface	IrDA PC/Keyboard/Printer interface, RS-232 serial communications, USB support @ 1.5Mbps and 12 Mbps, external VGA Video/Monitor port, and Bar Code Reader Port
Display	7.7in VGA passive matrix color LCD; 640x480, 256 colors		
Touch Screen	Analog Resistive		Analog Resistive, screen draw, handwriting recognition
Dimensions	Dia: 290mm (11.42 in), Depth w/o handle: 80mm (3.15 in), w/handle: 130mm (5.12 in)		(L x W x D) 28 x 22 x 5cm (11.8 x 8.4 x 2 in)
Weight (Approx.)	1.55 kg (3.4 lbs) w/o options		1.36 kg (4 lbs)
Base Communications	10Base-T Ethernet		Wireless Ethernet, WiFi Compliant 802.11B, Direct Sequencing, Tx Power: 15dBm, RxSENS: -83 dBm to -90 dBm
Supply Voltage Range	18 to 32V dc (24V dc nominal)		Lithium Ion 3100 mAh battery (8 hr. typical operation)
Typical Input Current	300mA at 24V dc		AC Adapter/Battery Charger .7A@100-240V ac 50/60 Hz
Operating Temperature	0 to 50°C (32 to 122°F)		0 to 45°C (32 to 113°F)
Relative Humidity	5 to 95% noncondensing		
Protection Ratings	IP54		
S T A N D A R D A N D A G E N C Y C E R T I F I C A T I O N S			
General	EN 614-1, EN894-1, -2, -3, EN ISO 29241-10, CSA C22.2 NO 14, UL 508		CE, UL, ETS, FCC, Canadian Interference
Electromagnetic Emmission/Immunity	EN 50081-2, EN 50082-2		
General Safety	EN 61131-1, -2, EN 50178		
Machining Centers	prEN 1921, prEN 12417		
Safety of Machinery Standards	EN 954-1, EN 292-1, -2, EN 418, EN 60204-1		
Robot Systems	EN 755, ANSI/RIA, R15.06, R15.02/1, CAN/CSA-2434-94, ISO 10218		

MobileView System Configurations

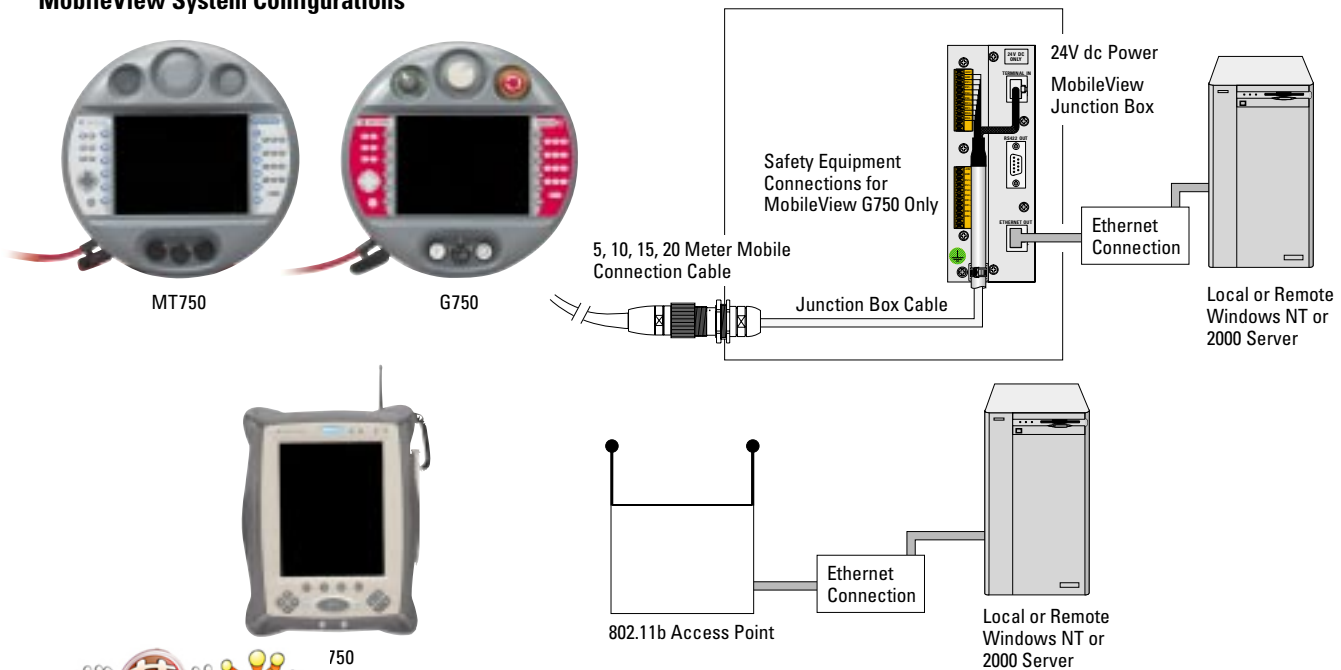

Message Displays

When you need devices to communicate information locally or across the factory floor, the Allen-Bradley Message Display family has a product for you.

- **InView Message Displays** for broad-band communication across the factory floor.
- **Dataliner Message Displays** for process and alarm information at the machine level.
- **RediPANEL Operator Modules** for pre-packaged, ready-to-use remote I/O push button applications.
- **MicroView** – text-based interface for monitoring and modifying controller data tables.



InView Message Displays

InView Message Displays deliver the 3 R's – the Right information, to the Right place, at the Right time. While the 3 R's are important, so is the way the message is delivered for different applications. InView offers several solutions – for process alarming, safety messages inventory or process data, or just thanking the team.

While many products can communicate information to one person about a single process – few can communicate to many at once. InView products offer 1-line, 2-line, 3-line, and 4-line displays, in red or tri-color LEDs for clear and colorful viewing from up to 350 feet.

InView Message Software

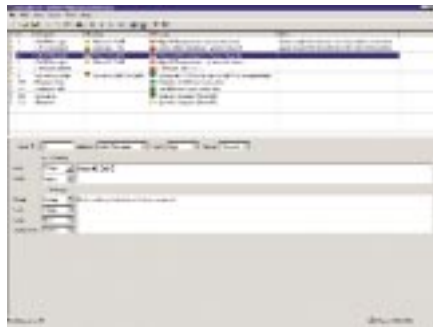

Step 1 – Message Editor

Use the Message Editor to develop your InView application file. First step is to create the message. Include attributes such as font color, size, scrolling, and embedded process variables.

InView's programming environment allows message categorization, as well as a message center that holds approved message files and their attributes – an easy way to organize your message files.

Step 2 – Message Previewer

See how your message will look on the display with Message Previewer. Previewing allows you to check your message and make changes to composition, spelling, and format, before download.

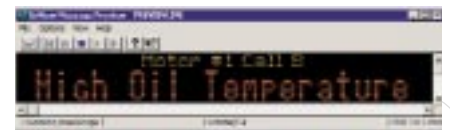

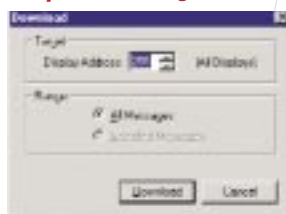

Step 3 – Message Download



Simply select the message or subset of messages for downloading and click. Once the download is complete, you're ready to deliver the 3 R's – the Right information to the Right place at the Right time.



InView Message Display Specifications

Catalog Number	2706-P43R 2706-P43C	2706-P42R, 2706-P42C ¹ 2706-P44R, 2706-P44C ²	2706-P72CN2 ¹ 2706-P74CN2 ²
			
D I S P L A Y			
Display Type	LED matrix: Red (R) or Tri-Color (C)	LED matrix: Red (R) or Tri-Color (C)	LED matrix: Tri-Color (C)
Display Size (W x H)	68.1 x 4 in (173.2 x 10.2 cm)	36 x 4.8 in (81.4 x 12.2 cm) ¹ 72 x 4.8 in (182 x 12.2 cm) ²	36 x 7.2 in (91.4 x 18.3 cm) ¹ 60 x 7.2 in (152.4 x 18.3 cm) ²
Display Array	120 x 7 pixels	120 x 16 or 240 x 16 pixels	120 x 24 or 200 x 24 pixels
Center to Center Pixel Spacing (Pitch)	0.57 in	0.3 in	0.3 in
Number of Lines	1	1 or 2	1 to 4
Lines of Text/Character Height/Minimum Characters per Line	1 line / 4 inches / 20 characters	1 line / 4.8 inches / 12 ¹ or 24 ² 2 line / 2.1 inches / 20 ¹ or 40 ²	1 line / 7.2 inches / 12 ¹ or 20 ² 2 line / 3.0 inches / 20 ¹ or 33 ² 3 line / 2.1 inches / 20 ¹ or 33 ² 4 line / 1.5 inches / 24 ¹ or 40 ²
Character Set	Standard and Extended ASCII	Standard and Extended ASCII	Standard and Extended ASCII
Approximate Viewing Distance	200 ft (60m)	200 ft (60m)	350 ft (100m)
E L E C T R I C A L & E N V I R O N M E N T A L			
Input Voltage	120-240V ac; 50/60 Hz	120-240V ac; 50/60 Hz	120-240V ac; 50/60 Hz
Operating Temperature	0 - 50°C (32 to 122°F)	0 - 50°C (32 to 122°F)	0 - 50°C (32 to 122°F)
Humidity	5 to 95% noncondensing	5 to 95% noncondensing	5 to 95% noncondensing
Ratings	NEMA 12	NEMA 12	NEMA 4, 4X
Certifications	ETL, CE marked	ETL, CE marked	ETL, CE marked
Enclosure Approximate Weight	40 lbs (18 kg)	28 lbs (12.7 kg) or 50 lbs (22.7 kg)	60 lbs (27.2 kg) or 80 lbs (36.3 kg)
Enclosure Dimensions (W x D x H)	71.9 x 5.5 x 7.88 in (182.7 x 13.97 x 20.0 cm)	40.38 x 5.5 x 7.88 in ¹ (102.57 x 13.97 x 20.0 cm) 76.38 x 5.5 x 7.88 in ² (194.0 x 13.97 x 20.0 cm)	42.25 x 6.0 x 13.75 in ¹ (107.32 x 15.24 x 34.93 cm) 66.25 x 6.0 x 13.75 in ² (168.28 x 15.24 x 34.93 cm)

¹ Available as 3 ft (91.44 cm) enclosure

² Available as 6 ft (182.88 cm) enclosure



Dataliner DL40 Plus

The Dataliner DL40 Plus offers hardware and feature enhancements designed to speed plant-floor system integration at a more competitive price. All master displays have 128K memory to store up to 4,000 preprogrammed messages and 16K of data logging memory. They communicate via Remove I/O, parallel port, or serial connection. Slave-only units display targeted messages from a master serial device, or can be connected to a PanelView terminal for enhanced alarm messaging. No programming required.

- **Two- or four-line displays with 20 characters per line**
- **11 mm (0.44 in) VFD characters visible up to 25 feet (7.6 m)**
- **Front panel push buttons to acknowledge messages, select operation modes, and set parameters**
- **Remote I/O or Parallel port versions, both with RS-232 and RS-485 ports**
- **Concurrent RS-232 and RS-485 communications for message triggering in both point-to-point and network configurations**
- **Slave-only version with RS-232 and RS-485 ports**
- **Replacement for DL40, DL20, and DL10 Dataliner displays**
- **English, International, and Cyrillic character sets**
- **Multiple run modes for application flexibility**

Dataliner DL50

Dataliner DL50 message displays are the choice for plant-wide messaging needs. Red or tri-color messages, in character heights ranging from 2 to almost 5 inches, get operators' attention up to 240 feet away. Because of this visibility, the DL50 is ideal as a slave device to the Dataliner DL40 Plus. A single DL40 Plus can drive several DL50 message displays, distributing important alarm or process information across your entire manufacturing area.

- **Red or Tri-color LED messages visible up to 240 feet (73 m)**
- **Selectable character size to display 2 lines of 2.1 inch (53 mm) or 1 line of 4.8 inch (122 mm) characters**
- **10 or 20 characters per line**
- **Scrolling to display long messages**
- **23 display modes for a wide range of visual effects such as wipe down and starburst**
- **Serial (RS-232/RS-485) communication with Dataliner DL40 Plus, PanelView, or other ASCII device**

Dataliner DL5

The smallest message display in the Dataliner family is the compact Dataliner DL5. Available in one- or two-line versions, these terminals are designed for panel mounting in an industrial environment, and can display messages that are visible up to 10 feet away.

The DL5 stores up to 387 pre-programmed messages and displays them when commanded by a controlling device. These messages can relate status conditions, display variable data, prompt an operator for action, or help diagnose a problem.

- **Compact one or two-line displays with 16 characters per line**
- **5 mm (0.2 in) VFD characters visible up to 10 feet (3 m)**
- **Up to 387 messages programmed via an ASCII terminal or with PC-compatible offline software**
- **Multiple run modes for application flexibility**
- **Parallel or serial (RS-232) communication**

MicroView

The MicroView operator interface for the MicroLogix controller is the lowest-cost offering of the DTAM family. Its compact size is designed for the OEM who wants a simple yet functional interface for machine control and data monitoring.

Panel mount and hand-held versions are available which store up to 50 application screens. A panel mount adapter allows the hand-held version to be easily removed for programming and replacement.

The MicroView is programmed using the DTAM offline development software package.

- **Compact size**
- **2 line x 16 character backlit LCD display**
- **Hand-held and panel mount versions for mounting flexibility**
- **RS-232 DF1 point-to-point communication with MicroLogix controllers**
- **Storage for up to 50 application screens**
- **2 function keys and numeric keypad for triggering screen displays, navigating to screens, and to set or clear data table bits**
- **Point-Access/Display feature to monitor or modify controller data files, regardless of the programmed screen**



Dataliner DL40 Plus**Dataliner DL50****Dataliner DL5****MicroView**

D I S P L A Y				
Type	Vacuum Fluorescent (VFD) 5x7 dot matrix characters Adjustable 0 to 100% brightness level	LED matrix Red or Tri-Color	Vacuum Fluorescent (VFD) 14 segment characters	LCD with LED backlight
Character Height	11.3mm (0.44 in)	122mm (4.8 in) or 5.33mm (2.1 in) selectable	1-line: 6.65mm (0.262 in) 2-line: 5.50mm (0.261 in)	0.22 x 0.12" (5.56 x 2.96 mm)
Characters per Line	20	10 to 40	16	16
Number of Lines	2 or 4	1 or 2	1 or 2	2
Character Set	Standard and Extended ASCII International ISO-8859-1 Cyrillic	Standard and Extended ASCII	Alphanumeric; uppercase only	Standard and Extended ASCII
Approximate Viewing Distance	7.62m (25 ft)	2.1 in chars: 30.5m (100 ft) 4.8 in chars: 73m (240 ft)	3m (10 ft)	0.6m (2 ft)
Memory	128K (up to 4000 messages)	N/A	2K EEPROM (94 messages) 8K EEPROM (387 messages)	Up to 50 application screens
E L E C T R I C A L				
Input Voltage	100 – 240V ac; 50 – 60 Hz	95 – 240V ac; 50 – 60 Hz	12 – 24V dc	11 – 25V dc
Input Current	0.60 to 0.25A	0.45 to 2A	12V dc 250mA 24V dc 125mA 300mA inrush	140mA @ 11V 60mA @ 25V
Communications Port	Remote I/O, Parallel, RS-232, RS-485	RS-232, RS-485	Parallel, RS-232	DF1 (to MicroLogix)
Keyboard Port	Standard IBM PC XT, AT or compatible; 8-pin DIN (large style)	N/A	N/A	N/A
E N V I R O N M E N T A L				
Operating Temperature	0 to 60°C (32 to 140°F)	0 to 60°C (32 to 140°F)	0 to 50°C (32 to 122°F)	0 to 55°C (32 to 131°F)
Storage Temperature	-40 to 85°C (-40 to 185°F)	-40 to 85°C (-40 to 185°F)	-40 to 85°C (-40 to 185°F)	-20 to 70°C (-4 to 158°F)
Humidity	5 to 95% noncondensing	5 to 95% noncondensing	5 to 95% noncondensing	5 to 95% noncondensing
Ratings	NEMA Type 12, 13, 4, 4X (indoor use only), IP64, IP65	NEMA Type 12, 13	NEMA Type 12, 13, 4	NEMA Type 1, 4 (panel-mount)
Certifications	UL, cUL approved; Class 1 Div 2 Groups A,B,C,D; CE marked	UL, cUL approved; CE marked	UL, CSA approved; Class 1 Div 2 Groups A,B,C,D	UL, CSA approved; Class 1 Div 2 Groups A, B, C, D (panel-mount); CE marked
Weight	2-line: 3.7 lbs (1.7 kg) 4-line: 4.9 lbs (2.2 kg)	1 x 10: 40 lbs (18 kg) 1 x 20: 75 lbs (34 kg)	3 lbs (1.35 kg)	0.44 lbs (0.2 kg)
Dimensions	2-line: 4.38"(h) x 14.37"(w) x 3.19"(d) (111mm x 365mm x 81mm) 4-line: 6.6"(h) x 14.37"(w) x 3.19"(d) (156mm x 365mm x 81mm)	1 x 10: 10.7"(h) x 40.4"(w) x 4.9"(d) (271mm x 1026mm x 125mm) 1 x 20: 10.7"(h) x 76.0"(w) x 4.9"(d) (271mm x 1930mm x 125mm)	3.12"(h) x 6.25"(w) x 4.31"(d) (7.93mm x 159mm x 109mm)	5.1"(h) x 3.6"(w) x 1.0"(d) (129.5 mm x 90.2 mm x 25.4 mm)



RediPANEL Operator Modules

Eliminate the time and expense of installing and wiring individual push buttons with RediPANEL Operator Modules.

These modules combine push buttons, keypads, displays, and wiring into pre-packaged, ready-to-use units for a quick and economical way to simplify panel fabrication. Available in several models, they install in just a few simple steps. And they withstand a variety of harsh environmental conditions.

Pre-assembled, pre-wired RediPANEL modules come with all the necessary electronics built right in. Each module communicates to a PLC controller via the Remote I/O network using a single cable. Configuration is simply identifying input or output points in PLC ladder logic; no special instructions are required.

Many of the RediPANEL modules are equipped with LEDs to display communication status. Many also have special built-in diagnostic test functions for pilot lights and push button contacts.

With RediPANEL modules at your control, you can:

- Install operator panels in a fraction of the time and cost it takes to hardwire individual push buttons
- Configure push buttons with ease
- Troubleshoot and remedy problems quickly



- **800A push button modules available in 8, 16, or 32 button configurations**
- **800EM or 800EP push button modules available in 16 or 32 button configurations**
- **Membrane modules with red LED indicators available with 16 membrane switches; legend inserts in red, green, amber, blue, and white**
- **Keypad modules combine membrane switches, LED indicators, numeric and function keypads, VFD display**
- **Standard and custom units**
- **Remote I/O communication**

	800A RediPANEL	800EM or 800EP RediPANEL	Membrane	Keypad
O P E R A T O R S				
Pushbutton Type	800A-C2 8 unit: 4 red, 4 green 16 unit: 6 red, 6 green, 4 amber 32 unit: 8 red, 8 green, 8 amber, 8 white	800EM-LF or 800EP-LF 16 unit: 8 red, 4 green, 4 amber 32 unit: 12 red, 14 green, 6 amber	Membrane with red LED indicators	Membrane with red LED indicators
Function Keys	N/A	N/A	N/A	6 with LED indicators
Display	N/A	N/A	N/A	VFD 1-line by 16 character
E L E C T R I C A L				
Power	AC: 90 – 264V ac DC: 18 – 30 V dc	AC: 90 – 264V ac DC: 18 – 30 V dc	AC: 90 – 264V ac DC: 18 – 30 V dc	85 – 264V ac
Comm. Port	Remote I/O	Remote I/O	Remote I/O	Remote I/O
E N V I R O N M E N T A L				
Operating Temperature	0 to 45°C (32 to 113°F)	0 to 40°C (32 to 104°F)	0 to 45°C (32 to 113°F)	0 to 60°C (32 to 140°F)
Storage Temperature	-40 to 85°C (-40 to 185°F)	-40 to 85°C (-40 to 185°F)	-40 to 85°C (-40 to 185°F)	-40 to 85°C (-40 to 185°F)
Humidity	5 to 95% noncondensing	5 to 95% noncondensing	5 to 95% noncondensing	5 to 95% noncondensing
Ratings	NEMA 12, 13	NEMA 12,13,4 (EM) NEMA 12,13,4,4x (EP)	NEMA 4, 4x	NEMA 4, 4x
Certifications	UL, CSA approved; Class 1 Div 2 Groups A,B,C,D (select models)	UL, CSA approved; Class 1 Div 2 Groups A,B,C,D	UL Listed; Class 1 Div 2 Groups A,B,C,D (select models)	UL Listed; Class 1 Div 2 Groups A,B,C,D





Catalog Number Index For Electronic Operator Interface Devices

PanelView Standard Operator Interface Terminals – Bulletin 2711Pages 57 to 60

- PanelView 300 Monochrome Terminals
- PanelView 300 Micro Monochrome Terminals
- PanelView 550 Monochrome Terminals
- PanelView 600 Color Terminals
- PanelView 1000 Grayscale Terminals
- PanelView 1000 Color Terminals
- PanelView 1400 Color Terminals
- Software
- Accessories and Replacement Parts

PanelView 'e' (Enhanced) Operator Interface Terminals – Bulletin 2711EPages 61 to 63

- PanelView 1000e Flat Panel Terminals
- PanelView 1400e CRT Terminals
- PanelBuilder 1400e Software Kits
- Panelbuilder 1200 Software Kits
- PanelView 1200 Migration Kits
- PanelView 1200e Migration Kits
- Accessories and Replacement Parts

MobileView Portable HMI – Bulletin 2727Page 63

- MobileView Machine Terminal MT750
- MobileView Guard G750
- MobileView MT750 and G750 Accessories
- MobileView Tablet T750
- MobileView T750 Accessories

Message Displays – Bulletins 2706, 2707, 2705Pages 64 to 66

- InView Message Displays and Accessories
- MicroView Operator Interface
- DL40 Plus Dataliner Message Displays, Accessories and Replacement Parts
- DL5 Dataliner Message Displays
- DL50 Dataliner Message Displays
- RediPANEL

▶ PanelView Standard Operator Interface Terminals

PanelView 300 Monochrome Terminals

Cat. No. Keypad²

DH-485 Communication Ports ¹	2711-K3A2L1
Monochrome, RS-232 (DH-485) Communication Port ¹	2711-K3A5L1
DeviceNet Communication & RS-232 Printer Port	2711-K3A10L1
RS-232 (DF1) Communication Port ¹	2711-K3A17L1

PanelView 300 Micro Monochrome Terminals

Cat. No. Keypad Only²

RS-232 (DF1) Communication Port, (8-Pin Mini-DIN) ¹	2711-M3A18L1
RS-232 (DH-485) Communication Port, (8-Pin Mini-DIN) ¹	2711-M3A19L1



PanelView 550 Monochrome Terminals	Cat. No. Keypad²³⁴	Cat. No. Keypad & Touch²³⁴	Cat. No. Touch²
DH-485 Communication Ports ¹	2711-K5A2	2711-B5A2	2711-T5A2L1
DH-485 Communication & RS-232 Printer Port ¹	2711-K5A3	2711-B5A3	2711-T5A3L1
RS-232 (DH-485) Communication Port ¹	2711-K5A5	2711-B5A5	2711-T5A5L1
RS-232 (DH-485) Communication & RS-232 Port ¹	2711-K5A9	2711-B5A9	2711-T5A9L1
Remote I/O Communication & RS-232 Printer Port	2711-K5A1	2711-B5A1	2711-T5A1L1
DH+ Communication & RS-232 Printer Port	2711-K5A8	2711-B5A8	2711-T5A8L1
DeviceNet Communication & RS-232 Printer Port	2711-K5A10	2711-B5A10	2711-T5A10L1
Profibus Communication & RS-232 Printer Port	2711-K5A12	2711-B5A12	2711-T5A12L1
Modbus Communication & RS-232 Printer Port	2711-K5A14	2711-B5A14	2711-T5A14L1
ControlNet Communication & RS-232 Printer Port	2711-K5A15	2711-B5A15	2711-T5A15L1
RS-232 (DF1) Communication & RS-232 Printer Port	2711-K5A16	2711-B5A16	2711-T5A16L1
EtherNet/IP Communication & RS-232 Printer Port	2711-K5A20	2711-B5A20	2711-T5A20L1

PanelView 600 Color Terminals	Cat. No. Keypad²	Cat. No. Keypad & Touch²	Cat. No. Touch²
DH-485 Communication Ports ¹	2711-K6C2	2711-B6C2	2711-T6C2L1
DH-485 Communication & RS-232 Printer Port ¹	2711-K6C3	2711-B6C3	2711-T6C3L1
RS-232 (DH-485) Communication Port ¹	2711-K6C5	2711-B6C5	2711-T6C5L1
RS-232 (DH-485) Communication & RS-232 Printer Port ¹	2711-K6C9	2711-B6C9	2711-T6C9L1
Remote I/O Communication & RS-232 Printer Port	2711-K6C1	2711-B6C1	2711-T6C1L1
DH+ Communication & RS-232 Printer Port	2711-K6C8	2711-B6C8	2711-T6C8L1
DeviceNet Communication & RS-232 Printer Port	2711-K6C10	2711-B6C10	2711-T6C10L1
Profibus Communication & RS-232 Printer Port	2711-K6C12	2711-B6C12	2711-T6C12L1
Modbus Communication & RS-232 Printer Port	2711-K6C14	2711-B6C14	2711-T6C14L1
ControlNet Communication & RS-232 Printer Port	2711-K6C15	2711-B6C15	2711-T6C15L1
RS-232 (DF1) Communication & RS-232 Printer/Download Port	2711-K6C16	2711-B6C16	2711-T6C16L1
EtherNet/IP Communication & RS-232 Printer Port	2711-K6C20	2711-B6C20	2711-T6C20L1

PanelView 1000 Grayscale Terminals	Cat. No. Keypad²	Cat. No. Touch²
DH-485 Communication & RS-232 Printer Port ¹	2711-K10G3	2711-T10G3
RS-232 (DH-485) Communication & RS-232 Printer Port ¹	2711-K10G9	2711-T10G9
Remote I/O Communication & RS-232 Printer Port	2711-K10G1	2711-T10G1
DH+ Communication & RS-232 Printer Port	2711-K10G8	2711-T10G8
DeviceNet Communications & RS-232 Printer Port	2711-K10G10	2711-T10G10
Profibus Communications & RS-232 Printer Port	2711-K10G12	2711-T10G12
Modbus Communications & RS-232 Printer Port	2711-K10G14	2711-T10G14
ControlNet Communications & RS-232 Printer Port	2711-K10G15	2711-T10G15
RS-232 (DF1) Communications & RS-232 Printer/Download Port	2711-K10G16	2711-T10G16
EtherNet/IP Communication & RS-232 Printer Port	2711-K10G20	2711-T10G20

PanelView 1000 Color Terminals	Cat. No. Keypad²	Cat. No. Touch²
DH-485 Communication & RS-232 Printer Port ¹	2711-K10C3	2711-T10C3
RS-232 (DH-485) Communication & RS-232 Printer Port ¹	2711-K10C9	2711-T10C9
Remote I/O Communication & RS-232 Printer Port	2711-K10C1	2711-T10C1
DH+ Communication & RS-232 Printer Port	2711-K10C8	2711-T10C8
DeviceNet Communication & RS-232 Printer Port	2711-K10C10	2711-T10C10
Profibus (1.5 Mb) Communication & RS-232 Printer Port	2711-K10C12	2711-T10C12
Modbus Communication & RS-232 Printer Port	2711-K10C14	2711-T10C14
ControlNet Communication & RS-232 Printer Port	2711-K10C15	2711-T10C15
RS-232 (DF1) Communication & RS-232 Printer/Download Port	2711-K10C16	2711-T10C16
EtherNet/IP Communication & RS-232 Printer Port	2711-K10C20	2711-T10C20

PanelView 1400 Color Terminals	Cat. No. Keypad	Cat. No. Touch
DH-485 Communication & RS-232 Printer Port ¹	2711-K14C3	2711-T14C3
RS-232 (DH-485) Communication & RS-232 Printer Port ¹	2711-K14C9	2711-T14C9



PanelView 1400 Color Terminals (continued)	Cat. No. Keypad	Cat. No. Touch
Remote I/O Communication & RS-232 Printer Port	2711-K14C1	2711-T14C1
DH+ Communication & RS-232 Printer Port	2711-K14C8	2711-T14C8
DeviceNet Communication & RS-232 Printer Port	2711-K14C10	2711-T14C10
Profibus (1.5 Mb) Communication & RS-232 Printer Port	2711-K14C12	2711-T14C12
Modbus Communication & RS-232 Printer Port	2711-K14C14	2711-T14C14
ControlNet Communication & RS-232 Printer Port	2711-K14C15	2711-T14C15
RS-232 (DF1) Communication & RS-232 Printer/Download Port	2711-K14C16	2711-T14C16
EtherNet/IP Communication & RS-232 Printer Port	2711-K14C20	2711-T14C20

PanelBuilder32 Configuration Software for the PanelView Operator Terminals

	Cat. No.
English	2711-ND3
Spanish	2711-ND3ES
French	2711-ND3FR
Italian	2711-ND3IT
German	2711-ND3DE

Accessories and Replacement Parts for PanelView Standard

Memory Cards

	Cat. No.
256 Kbyte Flash Memory Card (contact factory for availability)	2711-NM11
1M PC Flash Memory Card (contact factory for availability)	2711-NM12
2M PC Flash Memory Card (contact factory for availability)	2711-NM13
4M PC Flash Memory Card	2711-NM14
8M Flash ATA Memory Card	2711-NM28
10M Flash ATA Memory Card	2711-NM15
16M Flash ATA Memory Card	2711-NM216
Memory Card Retainer for PanelView 550, 600, 900, 1000 Keypad or Keypad & Touch	2711-NMCC
Memory Card Retainer for PanelView 550 Touch Only	2711-NMCD
Memory Card Retainer for PanelView 300/600 Touch Only (contact factory for availability)	2711-NMCE

Function Key Legend Kits

	Cat. No.
Function Key Legend Strips for the PanelView 300 Terminal (contact factory for availability)	2711-NF7
Function Key Legend Strips for the PanelView 550 Terminal	2711-NF1
Function Key Legend Strips for the PanelView 600 Terminal	2711-NF4
Function Key Legend Strips for the PanelView 900 Monochrome Terminal	2711-NF2A
Function Key Legend Strip for the PanelView 900 Color Terminal	2711-NF2C
Function Key Legend Strip for the PanelView 1000 Grayscale and Color Terminals	2711-NF6
Function Key Legend Strip for the PanelView 1400 Color Terminal	2711-NF5

Mounting Hardware

Replacement Mounting Clips for the PanelView 600 Keypad or Keypad & Touch/900/1000 Terminals	2711-NP2
Replacement Mounting Clips for the PanelView 1400 Terminal	2711-NP1
Mounting Studs for the PanelView 1400 Terminal	2711-NP3

Real-Time Clock Replacement

Real-Time Clock for PanelView 550 Keypad or Keypad & Touch (Series A through Series D)	2711-NB2
Real-Time Clock for PanelView 550 Keypad or Keypad & Touch (Series E or later), 600 Keypad or Keypad & Touch, 900, 1000, 1400 Terminals	2711-NB3
Real-Time Clock for PanelView 300 Keypad and PanelView 550/PanelView 600 Touch Screen Only Terminals	2711-NB4

1 PanelView standard terminals with DH-485 communications (2711-xxA2, -xxA3, -xxA5, -xxA9, -xxA19) or no RS-232 printer port (2711-xxx17, -xxx18, -xxx19) require application file uploads/downloads through the communication port. The RS-232 printer port on these terminals is for printing only.

2 Add L1 to the Catalog Number to order a PanelView 550, 600, or 1000 terminal with DC power instead of AC power (for example, 2711-K10C3L1). PanelView 300 Micro, 300, 550 Touch Only and 600 Touch Only terminals are 18 to 30V dc only.

3 Add L2 to the Catalog Number of the PanelView 550 Keypad or Keypad & Touch terminal to order a stainless steel terminal with AC power (for example, 2711-K5A5L2).

4 Add L3 to the Catalog Number of the PanelView 550 Keypad or Keypad & Touch terminal to order a stainless steel terminal with DC power (for example, 2711-B5A10L3).



Backlights

Replacement Backlight Lamp for all PanelView 550 Terminals	2711-NL1
Replacement Backlight Lamp for PanelView 600 Keypad or Keypad & Touch Terminal	2711-NL3
Replacement Backlight Lamp for PanelView 900 Color Terminal	2711-NL2
Replacement Backlight Lamp for PanelView 1000 Color Terminal (Series A Only)	2711-NL4
Replacement Backlight Lamp for PanelView 1000 Color Terminal (Series B Only) (contact factory for availability)	2711-NL6
Replacement Backlight Lamp for PanelView 1000 Color Terminal (Series C Only) (contact factory for availability)	2711-NL7

Antiglare Overlays

Antiglare Overlay for the PanelView 300 Terminal (Qty 3)	2711-NV8
Antiglare Overlay for the PanelView 550 Keypad or Keypad & Touch Terminal (Qty 3)	2711-NV4
Antiglare Overlay for the PanelView 550/600 Touch Screen Only Terminals (Qty 3)	2711-NV4T
Antiglare Overlay for the PanelView 600 Keypad or Keypad & Touch Terminals (Qty 3)	2711-NV5
Antiglare Overlay for the PanelView 900 Keypad Terminal (Qty 3)	2711-NV3K
Antiglare Overlay for the PanelView 900 Touch Screen Terminal (Qty 3)	2711-NV3T
Antiglare Overlay for the PanelView 1000 Keypad Terminal (Qty 3)	2711-NV6K
Antiglare Overlay for the PanelView 1000 Touch Screen Terminal (Qty 3)	2711-NV6T
Antiglare Overlay for the PanelView 1400 Keypad Terminal (Qty 3)	2711-NV7K
Antiglare Overlay for the PanelView 1400 Touch Screen Terminal (Qty 3)	2711-NV7T

Power Supply & Terminal Blocks

Wallmount power supply provides power to 1747-PIC Converter when SLC or network is not connected. 105 to 132V ac input. Separate operating/programming cable is required.	1747-NP1
DC Power Terminal Block for PanelView 300 Micro Terminal (Qty 10)	2711-TBDC

Cables

Personal Computer Interface Converter converts RS-232 signals to/from DH-485 signals.	1747-PIC
6 foot (1.83 meter) DH-485 Operating/Programming Cable (for 2711-xxA2, -xxA3, -xxC2, -xxC3, -xxG3)	1747-C10
1 foot (0.30 meter) DH-485 Operating/Programming Cable (for 2711-xxA2, -xxA3, -xxC2, -xxC3, -xxG3)	1747-C11
20 foot (6.1 meter) DH-485 Operating/Programming Cable (for 2711-xxA2, -xxA3, -xxC2, -xxC3, -xxG3)	1747-C20
Isolated Link Coupler for DH-485 Network	1747-AIC
AIC+ Advanced Interface Converter	1761-NET-AIC
Remote RS-232 Serial Port assembly for PanelView Standard terminals (with RS-232 Printer Ports) and PanelView 1000e/1400e terminals	2711-NC17
16.4 foot (5 meter) RS-232 Operating/Programming Cable (9-pin D-Shell to 9-pin D-Shell) ⁵	2711-NC13
32.7 foot (10 meter) RS-232 Operating/Programming Cable (9-pin D-Shell to 9-pin D-Shell)	2711-NC14
16.4 foot (5 meter) RS-232 Operating Cable for PanelView (2711-xxx5, -xxx9, -xxx16, -xxx17) to MicroLogix (9-pin D-Shell to 8-pin Mini DIN) ⁶	2711-NC21
49 foot (15 meter) RS-232 Operating Cable for PanelView (2711-xxx5, -xxx9, -xxx16, -xxx17) to MicroLogix (9-pin D-Shell to 8-pin Mini DIN) ⁶	2711-NC22
10 foot (3 meter) RS-232 Operating/Programming Cable (9-pin D-Shell to 9-pin D-Shell) ⁵	2706-NC13
16.4 foot (5 meter) RS-232 Operating Cable for PanelView 300 Micro Terminal to MicroLogix (8-pin Mini DIN to 8-pin Mini DIN)	2711-CBL-HM05
32.7 foot (10 meter) RS-232 Operating Cable for PanelView 300 Micro Terminal to MicroLogix (8-pin Mini DIN to 8-pin Mini DIN)	2711-CBL-HM10
16.4 foot (5 meter) RS-232 Operating Cable for PanelView 300 Micro Terminal to SLC or PLC (9-pin D-Shell to 8-pin Mini DIN)	2711-CBL-PM05
32.7 foot (10 meter) RS-232 Operating Cable for PanelView 300 Micro Terminal to SLC or PLC (9-pin D-Shell to 8-pin Mini DIN)	2711-CBL-PM10
1.5 foot (0.5 meter) RS-232 Operating Cable for PanelView 300 Micro to MicroLogix (8-pin Mini DIN to 8-pin Mini DIN)	1761-CBL-AM00
6.5 foot (2 meter) RS-232 Operating Cable for PanelView 300 Micro to MicroLogix (8-pin Mini DIN to 8-pin Mini DIN)	1761-CBL-HM02
1.5 foot (0.5 meter) RS-232 Operating/Programming Cable for PanelView 300 Micro to SLC or PLC (9-pin D-shell to 8-pin Mini DIN)	1761-CBL-AP00
6.5 foot (2 meter) RS-232 Operating/Programming Cable for PanelView 300 Micro to SLC or PLC (9-pin D-shell to 8-pin Mini DIN)	1761-CBL-PM02

⁵ Cable used for operation/communication with the following PanelViews: 2711-xxx5, -xxx9, -xxx16, -xxx17.

⁶ Cable used for application file transfer or printing with the following PanelViews: 2711-xxx1, -xxx3, -xxx8, -xxx9, -xxx10, -xxx12, -xxx14, -xxx15, -xxx16, -xxx17, -xxx20.

⁶ Null Modem not required.



► PanelView 'e' Operator Interface Terminals

PanelView 1000e Flat Panel Terminals, 10.4" (26.4cm) Color	Cat. No.	Cat. No.
Clip Mount, NEMA 4X (indoor only) with DH+ and Remote I/O Communications2711E-K10C62711E-T10C6
Clip Mount, NEMA 4X (indoor only) with DH+, Remote I/O, and ControlNet Release 1.5 Communications2711E-K10C152711E-T10C15
PanelView 1400e CRT Terminals, 14" (35.5cm) Color	Cat. No.	Cat. No.
Stud Mount, NEMA 4X (indoor only) with DH+ and Remote I/O Communications2711E-K14C62711E-T14C6
Stud Mount, NEMA 4X (indoor only) with DH+, Remote I/O, and ControlNet Release 1.5 Communications2711E-K14C152711E-T14C15
PanelBuilder 1400e Windows Development Software Kits for PanelView 1000e, 1200e, 1400e and enhanced Series F or G PanelView 1200 Terminals with Enhancement Kit (Cat. No. 2711E-U1B12C)		Cat. No.
English PanelBuilder 1400e Development Software for Windows 3.1 and above, Windows 95 or Windows NT Contains (1) Compact Disk (CD) with PanelBuilder 1400e Development Software, File Transfer Utility, Serial Firmware Upgrade Utility, Online Manuals, Floppy Disk Images for floppy disk installation, (1) PanelBuilder Getting Started Manual, (1) RSLinx Lite (on separate CD). Cables are NOT included and must be ordered separately.2711E-ND1
French PanelBuilder 1400e Development Software for Windows 3.1 and above, Windows 95 or Windows NT. Contents same as English Panel-BUILDER listed above except printed manuals provided instead of electronic versions.2711E-ND1FR
German PanelBuilder 1400e Development Software for Windows 3.1 and above, Windows 95 or Windows NT. Contents same as English Panel-BUILDER listed above except printed manuals provided instead of electronic versions.2711E-ND1DE
Spanish PanelBuilder 1400e Development Software for Windows 3.1 and above, Windows 95 or Windows NT. Contents same as English Panel-BUILDER listed above except printed manuals provided instead of electronic versions.2711E-ND1ES
English File Transfer Utilities for PanelView 1000e, 1200e, 1400e and enhanced Series F and G PanelView 1200 Terminals with Enhancement Kit (Catalog Number 2711E-U1B12C) and PV1200 Terminals. Note: Included in the PB1400e software kits. This is a stand-alone utility for file transfers only and requires less hard-disk space than the PanelBuilder 1400e software kits. These utilities are shipped on 3-1/2 inch floppy disks including RSLinx Lite.2711E-ND7
PanelBuilder 1200 Character Graphics CRT Terminal Software Kits for DOS and Windows		Cat. No.
English PanelBuilder 1200 Development Software for Windows 3.1 or later is used to develop application screens for PanelView 1200 Character Graphic Terminals. Contains user manuals, PanelBuilder 1200 Software on four 3-1/2 inch diskettes, File Transfer Utility on one 3-1/2 inch diskette, upload/download cable is NOT included (Use Cat. No. 2711-NC1)2711E-ND1W
English PanelBuilder 1200 Development Software for DOS is used to develop application screens for PanelView 1200 Character Graphic Terminals. Contains user manuals, PanelBuilder 1200 Software on one 3-1/2 inch diskette, Pass-through Download Utility on one 3-1/2 inch diskette, upload/download cable is NOT included (Use Cat. No. 2711-NC1)2711E-ND1
PanelView 1200/1200e to PanelView 1000e/1400e Migration Kits		
PanelView 1200 Migration Kits		Cat. No.
PanelView 1200 Keypad to PanelView 1000e Keypad Migration Kit. Includes (1) PV1000e DH+/RIO Keypad terminal (2711E-K10C6), (1) 2711-NR5K Cutout Adapter Kit and (1) 2711-NC13 Upload/Download Cable.2711E-UKCK10
PanelView 1200 Keypad to PanelView 1400e Keypad Migration Kit. Includes (1) PV1400e DH+/RIO Keypad terminal (2711E-K14C6).2711E-UKCK14
PanelView 1200 Touch to PanelView 1000e Touch Migration Kit. Includes (1) PV1000e DH+/RIO Touch terminal (2711E-T10C6), (1) 2711-NR5T Cutout Adapter Kit and (1) 2711-NC13 Upload/Download Cable.2711E-UTCT10
PanelView 1200 Touch to PanelView 1400e Touch Migration Kit. Includes (1) PV1400e DH+/RIO Touch terminal (2711E-T14C6).2711E-UTCT14
PanelView 1200e Migration Kits		Cat. No.
PanelView 1200e Keypad to PanelView 1000e Keypad Migration Kit. Includes (1) PV1000e DH+/RIO Keypad terminal (2711E-K10C6), (1) 2711-NR5K Cutout Adapter Kit and (1) 2711-NC13 Upload/Download Cable.2711E-UK12EK10
PanelView 1200e Keypad to PanelView 1400e Keypad Migration Kit. Includes (1) PV1400e DH+/RIO Keypad Migration Kit. Kit includes (1) PV1400e DH+/RIO Keypad terminal (2711E-K14C6).2711E-UK12EK14
PanelView 1200e Touch to PanelView 1000e Touch Migration Kit. Includes (1) PV1000e DH+/RIO Touch terminal (2711E-T10C6), (1) 2711-NR5T Cutout Adapter Kit and (1) 2711-NC13 Upload/Download Cable.2711E-UT12ET10
PanelView 1200e Touch to PanelView 1400e Touch Migration Kit. Includes (1) PV1400e DH+/RIO Touch terminal (2711E-T14C6).2711E-UT12ET14



Accessories and Replacement Parts for PanelView 'e' Operator Interface Terminals

Memory Cards

Cat. No.

1 Mbyte PCMCIA flash memory card for PanelView 1000e, 1200e, and 1400e terminals for additional application memory.2711-NM12
2 Mbyte PCMCIA flash memory card for PanelView 1000e, 1200e, and 1400e terminals for additional application memory.2711-NM13
4 Mbyte PCMCIA flash memory card for PanelView 1000e, 1200e, and 1400e terminals for additional application memory.2711-NM14
10 Mbyte PCMCIA flash memory card for PanelView 1000e, 1200e, and 1400e terminals for additional application memory.2711-NM15

Cables and Remote Keyswitch/Port Assemblies

Cat. No.

10 foot (3 meter) RS-232 Upload/Download Cable (9-pin to 25-pin) for PanelView 1400e (Series A-E), 1200e and 1200 terminals. For application file transfers between the terminal and development computer.2711-NC1
16 foot (5 meter) RS-232 Upload/Download Cable (9-pin to 9-pin) for PanelView 1000e and 1400e (Series F and later) terminals. For application file transfers between the terminal and development computer. Also used for PV300/550/600/900/1000/1400 terminals.2711-NC13
10 foot (3 meter) RS-232 Upload/Download Cable (9-pin to 9-pin) for PanelView 1000e and 1400e (Series F and later) terminals. For application file transfers between the terminal and development computer. Also used for PV300/550/600/900/1000/1400 terminals.2706-NC13
33 foot (10 meter) RS-232 Upload/Download Cable (9-pin to 9-pin) for PanelView 1000e and 1400e (Series F and later) terminals. For application file transfers between the terminal and development computer. Also used for PV300/550/600/900/1000/1400 terminals.2711-NC14
RS-232 Download Cable Adapter. Includes a 25-pin DB female to 9-pin DB female cable to adapt a (2711-NC1) 25-pin cable to any PanelView Standard, PV1000e, or PV1400e Series F or later terminals.2711-NC18
Remote keyswitch and RS-232 port assembly, with 3.1 m (10 ft) cable for PanelView 1400e (Series A-E), 1200e/1200 terminals.2711-NC2
Remote RS-232 Serial Port assembly for PanelView 1000e and 1400e (Series F and later) terminals. Includes a 9-pin RS-322 port assembly to allow remote serial port access.2711-NC17

Mounting Hardware and Adapters

Cat. No.

Mounting Clips for PanelView 600/900/1000/1000e Touch Screen and Keypad terminals.2711-NP2
Adapter to mount PanelView 1000/1000e Keypad terminal in panel cutout for a PanelView 1200/1400e Keypad terminals.2711-NR5K
Adapter to mount PanelView 1000/1000e Touch Screen terminal in panel cutout for a PanelView 1200 Touch Screen terminal.2711-NR5T
Adapter to mount PanelView 1000/1000e Touch Screen terminal in panel cutout for a PanelView 1400e Touch Screen terminal.2711-NR7T
19-inch Rack Mount Kit for PanelView 1400e Touch Screen terminals.2711-NR4
19-inch Rack Mount Kit for PanelView 1000/1000e Keypad terminals. Includes 19-inch rack adapter and mounting hardware for 1000/1000e clip mounted keypad terminals.2711-NR6K
19-inch Rack Mount Kit for PanelView 1000/1000e Touch Screen terminals. Includes 19-inch rack adapter and mounting hardware for 1000/1000e clip mounted touch screen terminals.2711-NR6T
ISA Card Adapter Kit for installing a communication card in a PanelView 1400e (Series A-E) terminal. Note: A ControlNet ISA Interface card (Catalog No. 1784-KTCS) is also required for ControlNet communication.2711E-NA1
ISA Card Adapter Kit for installing a communication card in a PanelView 1000e terminal. Note: A ControlNet ISA Interface card (Catalog No. 1784-KTCS) is also required for ControlNet communication2711E-NA2
ISA Card Adapter Kit for installing a communication card in a PanelView 1400e (Series F and later) terminals. Note: A ControlNet ISA/EISA Interface card (Catalog No. 1784-KTCS) is also required for ControlNet communication.2711E-NA3

Overlays and Keypad/Touch Screen Replacement Hardware

Cat. No.

Antiglare protective overlay for PanelView 1000/1000e Touch Screen terminals (Quantity of 3).2711-NV6T
Antiglare protective overlay for PanelView 1000/1000e Keypad terminals (Quantity of 3).2711-NV6K
Antiglare protective overlay for PanelView 1400e Keypad and Touch Screen terminals (Quantity of 5).2711E-NV1
Function Key Legend Inserts for PanelView 1000e Keypad terminals.2711E-NF1
Function Key Legend Inserts for PanelView 1400e Keypad terminals.2711E-NF2
Keypad Replacement Kit for PanelView 1400e Keypad terminals.2711E-NK5
Analog Touch Screen Replacement Kit for PanelView 1400e Touch Screen terminals.2711E-NT2

Backlights

Cat. No.

Backlight Replacement Kit for PanelView 1000e Terminals (Series C and earlier) terminals and 6189 Industrial Computers.6189-NL2
Backlight Replacement Kit for PanelView 1000e (Series D and later) terminals and PanelView 1000 (Series B)2711-NL6



Firmware and Memory Upgrade Kits

Cat. No.

Firmware Enhancement Kit for Modbus communications on PanelView 1000e/1400e terminals. Kit contains Modbus driver on a diskette and instructions. Note: You also need a Modbus ISA/EISA Interface Card and a 2711E-NA1, -NA2, or -NA3 Adapter Kit.	2711E-UMOD
System Memory Upgrade Kit for PanelView 1000e and 1400e (Series F and later) terminals. For 8 Mbyte total system RAM.	2711E-URAM1
System Memory Upgrade Kit for PanelView 1400e (Series A-E) terminals. For 4 Mbyte total system RAM.	2711E-URAM2

Miscellaneous Replacement Parts

Cat. No.

DH+ / Remote I/O Connector for PanelView 1000e/1200/1200e/1400e terminals. Also used for PV550/600/900/1000/1400 terminals.	2711-NDRC
Spare Mode Select Keys for PanelView 1000e/1200/1200e/1400e terminals.	2711E-NKEY1
Replacement Keyswitch Assembly for PanelView 1200/1200e/1400e (Series E or earlier) terminals.	2711E-NKSW1
Replacement Keyswitch Assembly for PanelView 1000e and 1400e (Series F or later) terminals.	2711E-NKSW2

► MobileView Portable HMI Devices

MobileView Machine Terminal MT750

Cat. No.

16MB DRAM/32MB Flash (Base Terminal)	2727-M7P20D1P1
64MB DRAM/64MB Flash, PC Card Slot (Standard Terminal)	2727-M7P20D1Q2
64MB DRAM/64MB Flash, PC Card Slot, Handwheel, Potentiometer, Keyswitch, 2 Normally Open Pushbuttons with Indicator LEDs (Standard Terminal with Options)	2727-M7P20D1Q3

MobileView Guard G750

Cat. No.

16MB DRAM/32MB Flash, 3-position Enable Switch	2727-G7P20D1P4
16MB DRAM/32MB Flash, 3-position Enable Switch, E-Stop	2727-G7P20D1P5
64MB DRAM/64MB Flash, 3-position Enable Switch, E-Stop, Handwheel, Potentiometer, Keyswitch, 2 Normally Open Pushbuttons with Indicator LEDs, PC Card Slot	2727-G7P20D1Q6

MobileView MT750 & G750 Accessories

Cat. No.

Junction Box	2727-MRJB1
Junction Box Cable, 2M (6.5 ft)	2727-MREX1
Connection Cable, 5M (16.4 ft) – connects to Junction Box Cable	2727-MRT5
Connection Cable, 10M (32.8 ft) – connects to Junction Box Cable	2727-MRT10
Connection Cable, 15M (49.2 ft) – connects to Junction Box Cable	2727-MRT15
Connection Cable, 20M (65.6 ft) – connects to Junction Box Cable	2727-MRT20
Mounting Bracket	2727-MRMB1
Serial Download Cable, 4M (13.1 ft)	2727-MRC1

MobileView Tablet T750

Cat. No.

32MB SDRAM/32MB Flash, 802.11B RF (Wireless), 32MB RAM Backup and File Storage, Includes Battery and AC Adapter/Battery Charger	2727-T7P30D1F
---	---------------

MobileView Tablet T750 Accessories

Cat. No.

AC Adapter/Battery Charger	2727-TRA7
Replacement Battery	2727-TRB7
Anti-Glare Protective Overlay, 10-pack	2727-TRG7
Stylus with Tether, 5-pack	2727-RY1
Power Kit (includes Battery, Battery Charger, AC Adapter)	2727-TRSP1



▶ Message Displays

InView Message Displays

	Cat. No.
1 or 2 lines, 12 or 20 characters, 4.8" to 2.1" high, Red LEDs, NEMA Type 12	.2706-P42R
1 or 2 lines, 12 or 20 characters, 4.8" to 2.1" high, Tri-Color LEDs, NEMA Type 12	.2706-P42C
1 line, 20 characters, 4" high, Red LEDs, NEMA Type 12	.2706-P43R
1 line, 20 characters, 4" high, Tri-Color LEDs, NEMA Type 12	.2706-P43C
1 or 2 line, 24 or 40 characters, 4.8" or 2.1" high, Red LEDs, NEMA Type 12	.2706-P44R
1 or 2 line, 24 or 40 characters, 4.8" or 2.1" high, Tri-Color LEDs, NEMA Type 12	.2706-P44C
1 to 4 line, 12 or 24 characters, 7.2" or 1.5" high, Tri-Color LEDs, NEMA Type 4	.2706-P72CN2
1 to 4 line, 12 or 40 characters, 7.2" or 1.5" high, Tri-Color LEDs, NEMA Type 4	.2706-P74CN2
1 2 to 4 line, 12 or 24 characters, 7.2" or 1.5" high, Tri-Color LEDs, NEMA Type 4X	.2706-P72CN1
1 to 4 line, 12 or 40 characters, 7.2" or 1.5" high, Tri-Color LEDs, NEMA Type 4X	.2706-P74CN1

InView Accessories

Messaging Software with ActiveX control	.2706-PSW1
Program Download Cable	.2706-PCABLE1
Ethernet TCP/IP Communications Module	.2706-PENET1
InView EtherNet/IP Communications Module (contact factory for availability)	.2706-PENI
InView DeviceNet Communications Module (contact factory for availability)	.2706-PDNI

MicroView Operator Interface

	Cat. No.
MicroView Operator Interface, Hand-Held	.2707-MVH232
MicroView Operator Interface, Panel Mount	.2707-MVP232
MicroView Offline Programming Software	.2707-NP2
Panel Mount Adapter for Hand-Held MicroView	.2707-MVMNT
RS-232 Program Upload/Download Cable, 6.5 ft (2 m)	.2707-NC8
MicroView to MicroLogix Communications Cable, 49 ft (15 m)	.2707-NC9
MicroView to MicroLogix Communications Cable, 6.5 ft (2 m)	.2707-NC11
MicroView 120V AC Power Supply Adapter	.2707-PS120
MicroView 240V AC Power Supply Adapter	.2707-PS220

DL40 Plus Dataliner Message Displays

	Cat. No.
Two-Line DL40 Plus Dataliner, 128K memory, Remote I/O communications.	.2706-LV2R
Two-Line DL40 Plus Dataliner, 128K memory, Parallel Port communications.	.2706-LV2P
Four-Line DL40 Plus Dataliner, 128K memory, Remote I/O communications.	.2706-LV4R
Four-Line DL40 Plus Dataliner, 128K memory, Parallel Port communications.	.2706-LV4P
Two-Line DL40 Plus Slave Display.	.2706-LV2S
Four-Line DL40 Plus Slave Display.	.2706-LV4S

DL40 Accessories

	Cat. No.
DL40 Plus Offline Programming Software (DOS based) 3.5 inch diskettes.	.2706-LSW
DL40 Plus Firmware Update Utility (DOS-based).	.2706-NR5
Programming Cable for IBM or compatible computers, 25-pin female connector, 9 ft (2.7 m).	.2706-NC12
Programming Cable for Allen-Bradley 6121, IBM or compatible computers, 9-pin female connector, 15 ft (4.6 m).	.2706-NC13
Programming Cable for Allen-Bradley 6120 computers, 9-pin female connector, 9 ft (2.7 m).	.2706-NC14
Programming Cable for Allen Bradley Industrial Terminals T1 through T4, 25-pin female connector, 9 ft (2.7 m).	.2706-NC15
NEMA Type 12/13 enclosure for Two-line DL40 Plus display.	.2706-NE1
NEMA Type 12/13 enclosure for Four-Line DL40 Plus display.	.2706-NE2



DL40 Replacement Parts**Cat. No.**

DL40 Plus 2-Line Front Panel Assembly	77156-800-01
DL40 Plus 4-Line Front Panel Assembly	77156-800-02
DL40 Plus Slave 2-Line Front Panel Assembly	77156-800-03
DL40 Plus Slave 4-Line Front Panel Assembly	77156-800-04

DL5 Dataliner Message Displays**Cat. No.**

One-Line DL5 Dataliner, 2K memory (94 message blocks) (CE only)	2706-D11J2
Two-Line DL5 Dataliner, 2K memory (94 message blocks) (CE only)	2706-D21J2
Two-Line DL5 Dataliner, 8K memory (387 message blocks) (CE only)	2706-D21J8
One-Line DL5 Slave Dataliner	2706-D11JS
Two-Line DL5 Slave Dataliner	2706-D21JS
Offline Programming Software (DOS based) for the DL5 Series displays, 3.5" diskettes	2706-NP5
Programming Cable for IBM or compatible computers (including Allen-Bradley 6180 Industrial Computers), 25-pin female connector, 9ft (2.7 m)	2706-NC12
Programming Cable for Allen-Bradley 6121, IBM or compatible computers, 9-pin female connector, 15 ft (4.6 m)	2706-NC13
Programming Cable for Allen-Bradley 6120 computers, 9-pin female connector, 9 ft (2.7 m)	2706-NC14
Programming Cable for Allen Bradley Industrial Terminals T1 through T4, 25-pin female connector, 9 ft (2.7 m)	2706-NC15

DL50 Dataliner Message Displays**Cat. No.**

Red display, 2 lines of twenty 2.1 inch (53.3mm) characters or one line of ten 4.8 inch (122mm) characters	2706-F11J
Red display, 2 lines of forty 2.1 inch (53.3mm) characters or one line of twenty 4.8 inch (122mm) characters	2706-F21J
Tri-color display, 2 lines of twenty 2.1 inch (53.3mm) characters or one line of ten 4.8 inch (122mm) characters	2706-F11JC
Tri-color display, 2 lines of forty 2.1 inch (53.3mm) characters or one line of twenty 4.8 inch (122mm) characters	2706-F21JC
Mounting bracket for back to back or wall mounting. Bracket angle is adjustable	2706-NJ3

DL50 Replacement Parts**Cat. No.**

DL50 Dataliner Power Supply Kit	77128-810-02
DL50 Dataliner Processor Board Kit	77128-811-03
DL50 Dataliner Display Board Kit	77128-812-01

RediPANEL Standard Units – Bulletin 800EP**Cat. No.**

32 Button, 120/240V AC, Stainless Steel Faceplate Mounting	2705-EP11S1
32 Button, 120/240V AC, Stainless Steel Faceplate Mounting, LED Bulbs	2705-EP11S1L
32 Button, 24V DC, Stainless Steel Faceplate Mounting, LED Bulbs	2705-EP11S2L
32 Button, 120/240V AC, Enclosure Mounting	2705-EP11SE1
32 Button, 120/240V AC, Enclosure Mounting, LED Bulbs	2705-EP11SE1L
32 Button, 24V DC, Enclosure Mounting, LED Bulbs	2705-EP11SE2L
16 Button, 120/240V AC, Stainless Steel Faceplate Mounting	2705-EP21S1
16 Button, 120/240V AC, Stainless Steel Faceplate Mounting, LED Bulbs	2705-EP21S1L
16 Button, 24V DC, Stainless Steel Faceplate Mounting, LED Bulbs	2705-EP21S2L
16 Button, 120/240V AC, Enclosure Mounting	2705-EP21SE1
16 Button, 120/240V AC, Enclosure Mounting, LED Bulbs	2705-EP21SE1L
16 Button, 24V DC, Enclosure Mounting, LED Bulbs	2705-EP21SE2L



RediPANEL Standard Units – Bulletin 800EM

	Cat. No.
32 Button, 120/240V AC, Faceplate Mounting	.2705-EM11J1
32 Button, 120/240V AC, Faceplate Mounting, LED Bulbs	.2705-EM11J1L
32 Button, 24V DC, Faceplate Mounting, LED Bulbs	.2705-EM11J2L
32 Button, 120/240V AC, Enclosure Mounting	.2705-EM11JE1
32 Button, 120/240V AC, Enclosure Mounting, LED Bulbs	.2705-EM11JE1L
32 Button, 24V DC, Enclosure Mounting, LED Bulbs	.2705-EM11JE2L
16 Button, 120/240V AC, Faceplate Mounting	.2705-EM21J1
16 Button, 120/240V AC, Faceplate Mounting, LED Bulbs	.2705-EM21J1L
16 Button, 24V DC, Faceplate Mounting	.2705-EM21J2L
16 Button, 120/240V AC, Enclosure Mounting	.2705-EM21JE1
16 Button, 120/240V AC, Enclosure Mounting, LED Bulbs	.2705-EM21JE1L
16 Button, 24V DC, Enclosure Mounting, LED Bulbs	.2705-EM21JE2L

RediPANEL Standard Units – Bulletin 800A

	Cat. No.
32 Button Standard, 120/240V AC	.2705-P11J1
32 Button Standard, 120/240V AC, LED Bulbs	.2705-P11J1L
32 Button Standard, 24V DC	.2705-P11J2
32 Button Standard, 24V DC, LED Bulbs	.2705-P11J2L
32 Button Class I, Division 2, 24V DC	.2705-P12J2
32 Button Class I, Division 2, 24V DC, LED Bulbs	.2705-P12J2L
32 Button Class I, Division 2, 120/240V AC	.2705-P12J3
32 Button Class I, Division 2, 120/240V AC, LED Bulbs	.2705-P12J3L
16 Button Standard, 120/240V AC	.2705-P21J1
16 Button Standard, 120/240V AC, LED Bulbs	.2705-P21J1L
16 Button Standard, 24V DC	.2705-P21J2
16 Button Standard, 24V DC, LED Bulbs	.2705-P21J2L
16 Button Class I, Division 2, 24V DC	.2705-P22J2
16 Button Class I, Division 2, 24V DC, LED Bulbs	.2705-P22J2L
16 Button Class I, Division 2, 120/240V AC	.2705-P22J3
16 Button Class I, Division 2, 120/240V AC, LED Bulbs	.2705-P22J3L
8 Button Standard, 120/240V AC	.2705-P31J1
8 Button Standard, 120/240V AC, LED Bulbs	.2705-P31J1L
8 Button Standard, 24V DC	.2705-P31J2
8 Button Standard, 24V DC, LED Bulbs	.2705-P31J2L
8 Button Class 1, Division 2, 24V DC	.2705-P32J2
8 Button Class 1, Division 2, 24V DC, LED Bulbs	.2705-P32J2L
8 Button Class 1, Division 2, 120/240V AC	.2705-P32J3
8 Button Class 1, Division 2, 120/240V AC, LED Bulbs	.2705-P32J3L

Membrane RediPANEL

	Cat. No.
16 Button Membrane RediPANEL, Red LED Indicators, 120/240V AC	.2705-P21C1
16 Button Membrane RediPANEL, Red LED Indicators, 24V DC	.2705-P21C2
16 Button Class 1 Division 2 Membrane RediPANEL, Red LED Indicators, 24V DC	.2705-P22C2
16 Button Class 1 Division 2 Membrane RediPANEL, Red LED Indicators, 120/240V AC	.2705-P22C3

Keypad RediPANEL

	Cat. No.
Keypad RediPANEL, 1 Line VFD, 120/240V AC	.2705-K11C1
Keypad Class 1 Division 2 RediPANEL, 1 Line VFD, 120/240V AC	.2705-K12C3
Keypad RediPANEL, Offline Programming Software	.2705-ND1



Transforming The Face Of Human Interface.

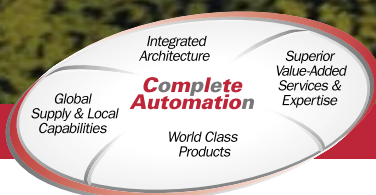

WELCOME TO THE WORLD OF COMPLETE AUTOMATION™

RSView Machine Edition™ High-level graphics, machine-level efficiency.

RSView ME from Rockwell Automation™ This revolutionary concept brings you the best of both worlds: enhanced visualization in a cost-effective machine-level platform. Plus, it provides flexibility and scalability unmatched by conventional HMI.

RSView ME provides machine-level operating data on both Windows® CE and 2000 computers, and in our future next-generation PanelView™ Plus dedicated platform. You can configure RSView ME to communicate on multiple networks at the same time, for both point-



plant-floor
a supports

seamless connectivity to a wide range of Allen-Bradley® devices as well as third-party systems.

Through our RSView Studio™, RSView ME shares a common development environment with any other ViewAnyWare components like RSView SE™, making programming simple and easy. Thus reducing development time dramatically and saving you up to 20% on development costs.

RSView ME from Rockwell Software™ Another high-productivity Complete Automation solution from Rockwell Automation. For complete information and a copy of *The View*, call **1-800-455-8234, ext 0971** Or visit our Web site:



RSView ME software and hardware platforms:

- Windows® CE open platform, 6182 Industrial Computer
- Windows® 2000 open platform, 6181 Industrial Computer



Bringing Together Leading Brands in Industrial Automation