

NAIS

## 16A Power Relay For Micro wave oven

LE-RELAYS

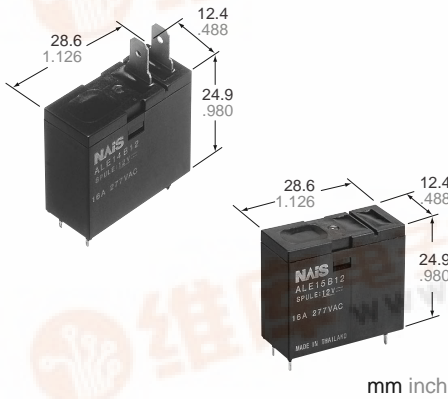

### FEATURES

1. Ideal for magnetron and heater loads
2. Excellent heat resistance
  - This satisfies UL coil insulation class B
3. High insulation resistance
  - Creepage distance and clearances between contact and coil: Min. 8 mm .315 inch
  - Surge withstand voltage: Min. 10,000V
4. Low operating power
  - Nominal operating power: 400mW

### 5. A wide variety of types

- Product line consists of 4 types with different shapes and pins

### 6. Conforms to the various safety standards:

- UL/CSA, TÜV, VDE approved and SEMKO available

### SPECIFICATIONS

#### Contact

Arrangement	1 Form A	
Initial contact resistance, max. (By voltage drop 6 V DC 1 A)	100 mΩ	
Contact material	Silver alloy	
Rating (resistive load)	Nominal switching capacity	16 A 277 V AC
	Max. switching power	4,432 V A
	Max. switching voltage	277 V AC
	Max. switching current	16 A
Expected life (min. operations)	Mechanical (at 180 cpm)	2 × 10 <sup>6</sup>
	Electrical (at 20 cpm) (Resistive load)	10 <sup>5</sup>

#### Coil

Nominal operating power	400 mW
-------------------------	--------

#### Remarks

- \* Specifications will vary with foreign standards certification ratings.
- \*<sub>1</sub> Measurement at same location as "Initial breakdown voltage" section.
- \*<sub>2</sub> Detection current: 10mA
- \*<sub>3</sub> Wave is standard shock voltage of ±1.2 × 50μs according to JEC-212-1981
- \*<sub>4</sub> Excluding contact bounce time.
- \*<sub>5</sub> Half-wave pulse of sine wave: 11 ms; detection time: 10 μs
- \*<sub>6</sub> Half-wave pulse of sine wave: 6 ms
- \*<sub>7</sub> Detection time: 10 μs
- \*<sub>8</sub> Refer to 5. Conditions for operation, transport and storage mentioned in AMBIENT ENVIRONMENT (Page 24).

#### Characteristics

Max. operating speed (at rated load)	20 cpm	
Initial insulation resistance* <sub>1</sub>	Min. 1,000 MΩ (at 500 V DC)	
Initial breakdown voltage* <sub>2</sub>	Between open contacts	1,000 Vrms for 1 min.
	Between contacts and coil	4,000 Vrms for 1 min.
Initial surge voltage between contact and coil* <sub>3</sub>	Min. 10,000 V	
Operate time* <sub>4</sub> (at nominal voltage)	Max. 20ms (at 20°C 68°F)	
Release time (with diode)* <sub>4</sub> (at nominal voltage)	Max. 20ms (at 20°C 68°F)	
Temperature rise (at nominal voltage)	Max. 55°C (resistance method, contact current 16 A, 20°C 68°F)	
Shock resistance	Functional* <sub>5</sub>	Min. 200 m/s <sup>2</sup> {20 G}
	Destructive* <sub>6</sub>	Min. 1,000 m/s <sup>2</sup> {100 G}
Vibration resistance	Functional* <sub>7</sub>	10 to 55Hz at double amplitude of 1.5mm
	Destructive	10 to 55Hz at double amplitude of 1.5mm
Conditions for operation, transport and storage* <sub>8</sub> (Not freezing and condensing at low temperature)	Ambient temp.	-40°C to +85°C -40°F to +185°F
	Humidity	5 to 85% R.H.
Unit weight	Approx. 17 g .60 oz	

### TYPICAL APPLICATIONS

- Microwave ovens
- Refrigerators
- OA equipment

### ORDERING INFORMATION

Ex. A LE 1 2 B 12

Product name	Contact arrangement	Terminal shape	Coil insulation class	Coil voltage, V DC
LE	1: 1 Form A	2: TMP type/PCB side three terminals (includes one dummy terminal) 3: TMP type/PCB side three terminals 4: TMP type/PCB side four terminals 5: PCB type (No tab terminals)	B: Class B insulation	05: 5 18: 18 06: 6 24: 24 09: 9 48: 48 12: 12

UL/CSA, TÜV, VDE approved type is standard.  
Note: Standard packing; Carton: 100 pcs. Case 500 pcs.



# LE TYPES

Contact arrangement	Coil voltage, V DC	TMP type/PCB side three terminals (includes one dummy terminal)	TMP type/PCB side three terminals	TMP type/PCB side four terminals	PCB type (No tab terminals)
		Part No.	Part No.	Part No.	Part No.
1 Form A	5	ALE12B05	ALE13B05	ALE14B05	ALE15B05
	6	ALE12B06	ALE13B06	ALE14B06	ALE15B06
	9	ALE12B09	ALE13B09	ALE14B09	ALE15B09
	12	ALE12B12	ALE13B12	ALE14B12	ALE15B12
	18	ALE12B18	ALE13B18	ALE14B18	ALE15B18
	24	ALE12B24	ALE13B24	ALE14B24	ALE15B24
	48	ALE12B48	ALE13B48	ALE14B48	ALE15B48

## COIL DATA (at 20°C 68°F)

Nominal voltage, V DC	Pick-up voltage, V DC (max.)	Drop-out voltage, V DC (min.)	Coil resistance, Ω(±10%)	Nominal operating current, mA (±10%)	Nominal operating power, W	Maximum allowable voltage, V DC
5	3.75	0.25	63	80	0.4	7.25
6	4.5	0.3	90	66.7		8.7
9	6.75	0.45	203	44.4		13.05
12	9	0.6	360	33.3		17.4
18	13.5	0.9	810	22.2		26.1
24	18	1.2	1,440	16.7		34.8
48	36	2.4	5,760	8.3	69.6	

## DIMENSIONS

**1. TMP type**  
PCB side three terminals  
(includes one dummy terminal)

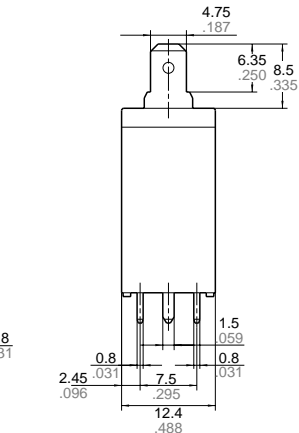
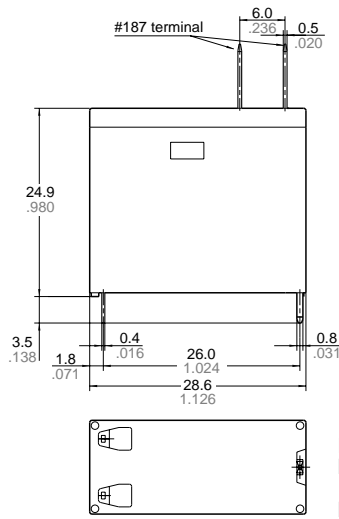

PC board pattern (Bottom view) mm inch

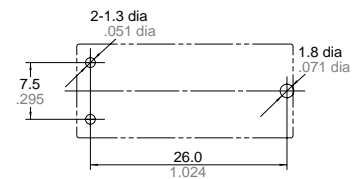

Tolerance : ±0.1 ±.004

Schematic (Bottom view)

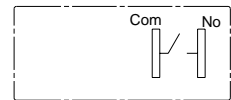

**Dimension:**  
 Max. 1mm .039 inch:  
 1 to 3mm .039 to .118 inch:  
 Min. 3mm .118 inch:

**Tolerance**  
 ±0.1 ±.004  
 ±0.2 ±.008  
 ±0.3 ±.012

PCB side three terminals

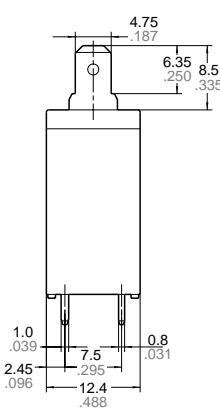
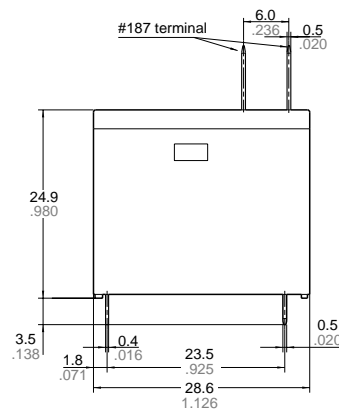

PC board pattern (Bottom view) mm inch

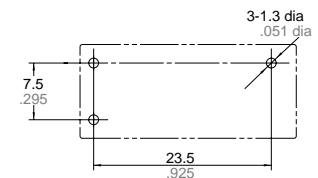

Tolerance : ±0.1 ±.004

Schematic (Bottom view)

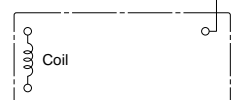
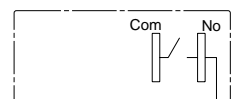

**Dimension:**  
 Max. 1mm .039 inch:  
 1 to 3mm .039 to .118 inch:  
 Min. 3mm .118 inch:

**Tolerance**  
 ±0.1 ±.004  
 ±0.2 ±.008  
 ±0.3 ±.012



PCB side four terminals

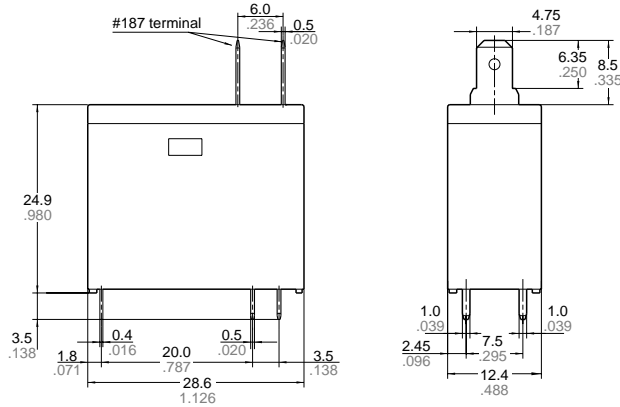

PC board pattern (Bottom view)

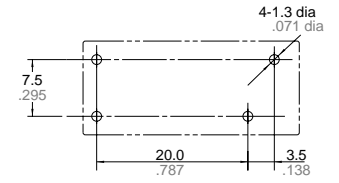

Tolerance :  $\pm 0.1 \pm .004$

Schematic (Bottom view)

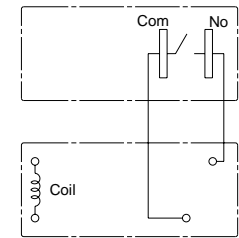

**Dimension:**  
 Max. 1mm .039 inch:  
 1 to 3mm .039 to .118 inch:  
 Min. 3mm .118 inch:

**Tolerance**  
 $\pm 0.1 \pm .004$   
 $\pm 0.2 \pm .008$   
 $\pm 0.3 \pm .012$

2. PCB type

PCB side four terminals  
 (No tab terminals)

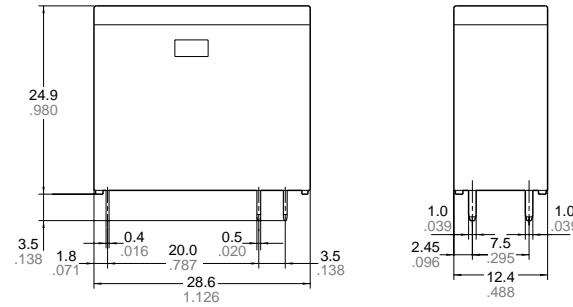

PC board pattern (Bottom view)

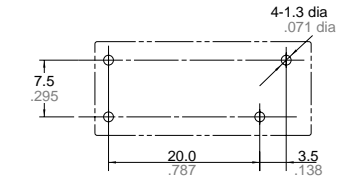

Tolerance :  $\pm 0.1 \pm .004$

Schematic (Bottom view)

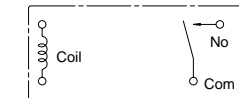

**Dimension:**  
 Max. 1mm .039 inch:  
 1 to 3mm .039 to .118 inch:  
 Min. 3mm .118 inch:

**Tolerance**  
 $\pm 0.1 \pm .004$   
 $\pm 0.2 \pm .008$   
 $\pm 0.3 \pm .012$

REFERENCE DATA

1. Coil temperature rise

Sample: ALE15B12, 6 pcs.  
 Point measured: coil inside  
 Ambient temperature: 25°C 77°F, 85°C 185°F

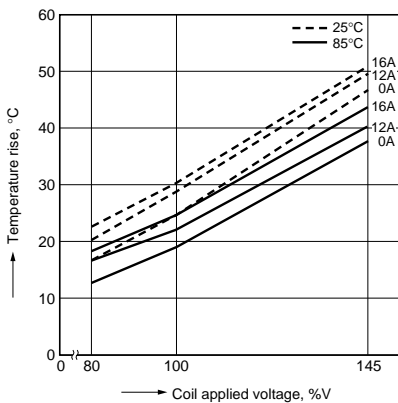

2. Life curve

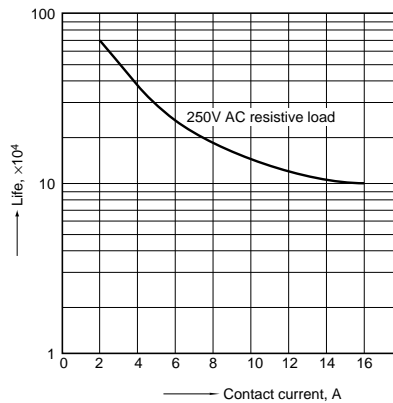

## 3. Electrical life test (16 A 277 V AC, resistive load)

Sample: ALE15B12, 6 pcs.

Operation frequency: 20 times/min.

(ON/OFF = 1.5s: 1.5s)

Ambient temperature: Room temperature

Circuit:

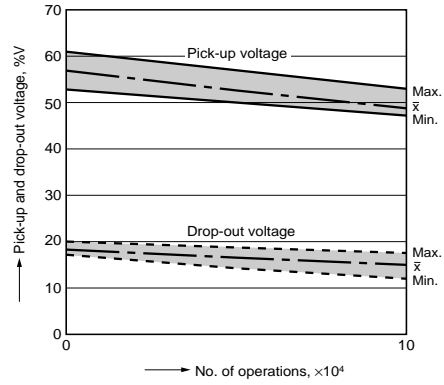
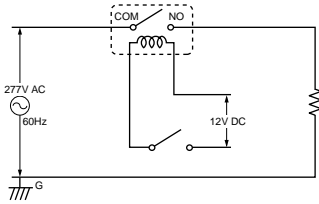

**For Cautions for Use, see Relay Technical Information (Page 11 to 39).**

