

TOSHIBA CMOS DIGITAL INTEGRATED CIRCUIT SILICON MONOLITHIC

**TC74ACT157P, TC74ACT157F, TC74ACT157FN, TC74ACT157FT**

**QUAD 2 - CHANNEL MULTIPLEXER**

The TC74ACT157 is an advanced high speed CMOS QUAD 2 - CHANNEL MULTIPLEXER fabricated with silicon gate and double - layer metal wiring C<sup>2</sup>MOS technology. It achieves the high speed operation similar to equivalent Bipolar Schottky TTL while maintaining the CMOS low power dissipation.

This device may be used as a level converter for interfacing TTL or NMOS to High Speed CMOS. The inputs are compatible with TTL, NMOS and CMOS output voltage levels. This device consist of four 2 - input digital multiplexer with common select and strobe inputs.

When the STROBE input is held "H" level, selection of data is inhibited and all the outputs become "L" level.

The SELECT decoding determines whether the A or B inputs get routed to their corresponding Y outputs.

All inputs are equipped with protection circuits against static discharge or transient excess voltage.

**FEATURES :**

- High Speed.....  $t_{pd} = 5.1ns(\text{typ.})$  at  $V_{CC} = 5V$
- Low Power Dissipation.....  $I_{CC} = 8\mu A(\text{Max.})$  at  $T_a = 25^\circ C$
- Compatible with TTL outputs...  $V_{IL} = 0.8V(\text{Max.})$   
 $V_{IH} = 2.0V(\text{Min.})$
- Symmetrical Output Impedance...  $|I_{OH}| = I_{OL} = 24mA(\text{Min.})$   
Capability of driving 50Ω transmission lines.
- Balanced Propagation Delays...  $t_{pLH} \approx t_{pHL}$
- Pin and Function Compatible with 74F157

(Note) The JEDEC SOP (FN) is not available in Japan.

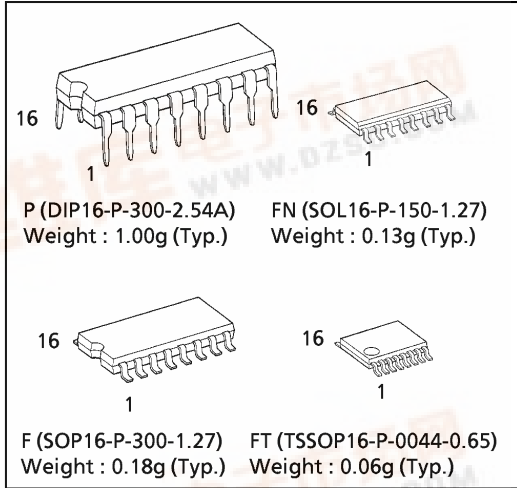

**PIN ASSIGNMENT**

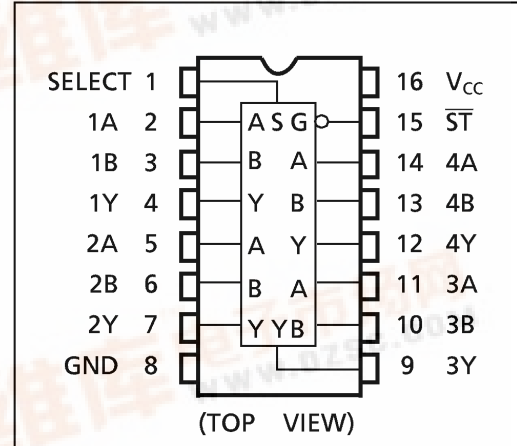

**TRUTH TABLE**

INPUTS				OUTPUTS
ST	SELECT	A	B	Y
H	X	X	X	L
L	L	L	X	L
L	L	H	X	H
L	H	X	L	L
L	H	X	H	H

X : Don't Care

**IEC LOGIC SYMBOL**

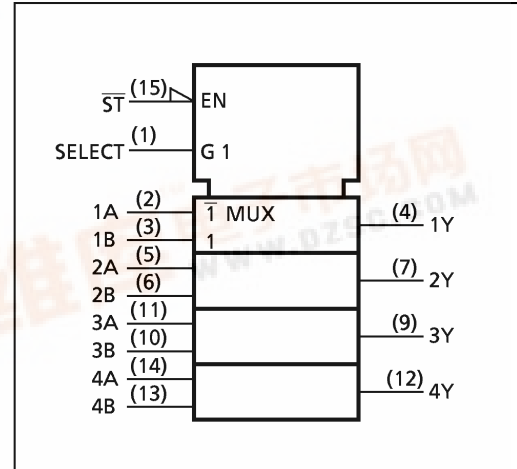

961001EBA2

● TOSHIBA is continually working to improve the quality and the reliability of its products. Nevertheless, semiconductor devices in general can malfunction or fail due to their inherent electrical sensitivity and vulnerability to physical stress. It is the responsibility of the buyer, when utilizing TOSHIBA products, to observe standards of safety, and to avoid situations in which a malfunction or failure of a TOSHIBA product could cause loss of human life, bodily injury or damage to property. In developing your designs, please ensure that TOSHIBA products are used within specified operating ranges as set forth in the most recent products specifications. Also, please keep in mind the precautions and conditions set forth in the TOSHIBA Semiconductor Reliability Handbook.



SYSTEM DIAGRAM

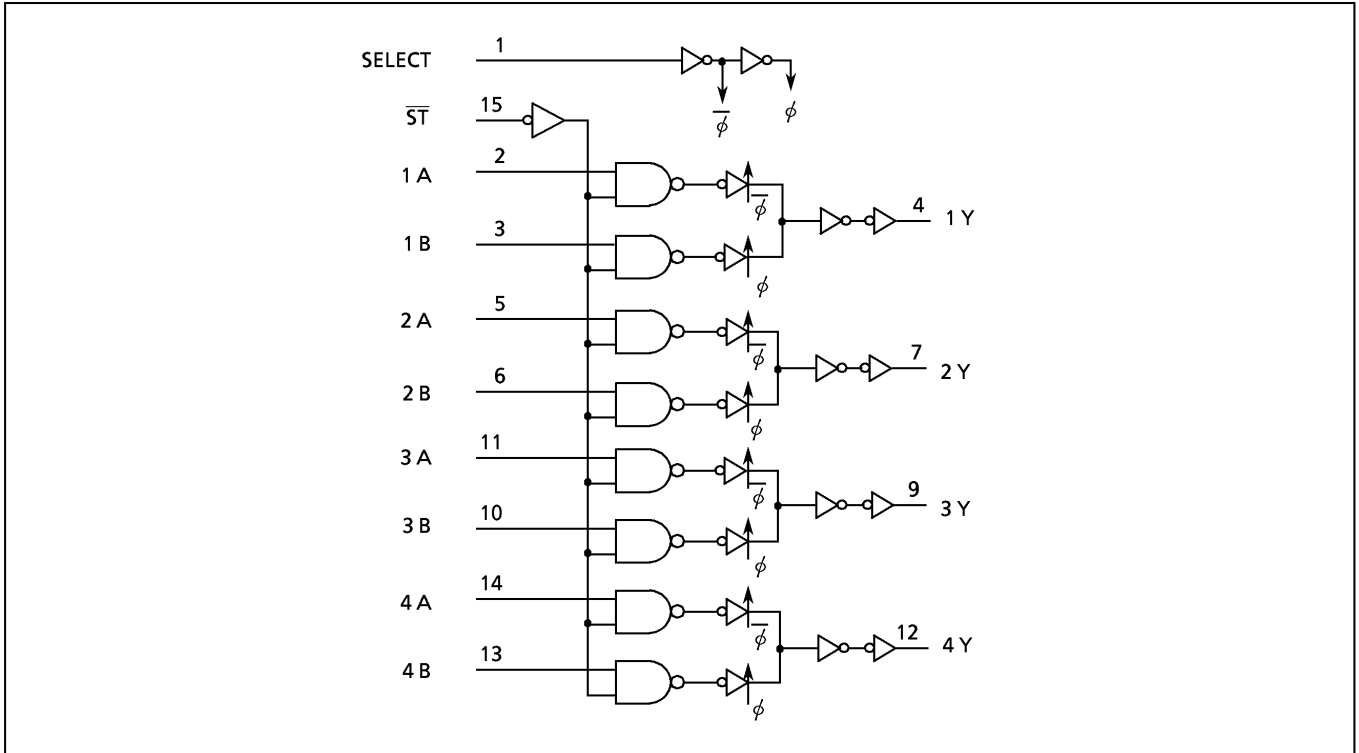

ABSOLUTE MAXIMUM RATINGS

PARAMETER	SYMBOL	VALUE	UNIT
Supply Voltage Range	$V_{CC}$	-0.5~7.0	V
DC Input Voltage	$V_{IN}$	-0.5~ $V_{CC} + 0.5$	V
DC Output Voltage	$V_{OUT}$	-0.5~ $V_{CC} + 0.5$	V
Input Diode Current	$I_{IK}$	± 20	mA
Output Diode Current	$I_{OK}$	± 50	mA
DC Output Current	$I_{OUT}$	± 50	mA
DC $V_{CC}$ /Ground Current	$I_{CC}$	± 100	mA
Power Dissipation	$P_D$	500 (DIP)* / 180 (SOP/TSSOP)	mW
Storage Temperature	$T_{stg}$	-65~150	°C

\*500mW in the range of  $T_a = -40^{\circ}C \sim 65^{\circ}C$ . From  $T_a = 65^{\circ}C$  to  $85^{\circ}C$  a derating factor of  $-10mW/^{\circ}C$  should be applied up to 300mW.

RECOMMENDED OPERATING CONDITIONS

PARAMETER	SYMBOL	VALUE	UNIT
Supply Voltage	$V_{CC}$	4.5~5.5	V
Input Voltage	$V_{IN}$	0~ $V_{CC}$	V
Output Voltage	$V_{OUT}$	0~ $V_{CC}$	V
Operating Temperature	$T_{opr}$	-40~85	°C
Input Rise and Fall Time	$dt / dV$	0~10	ns / V

961001EBA2'

- The products described in this document are subject to foreign exchange and foreign trade control laws.
- The information contained herein is presented only as a guide for the applications of our products. No responsibility is assumed by TOSHIBA CORPORATION for any infringements of intellectual property or other rights of the third parties which may result from its use. No license is granted by implication or otherwise under any intellectual property or other rights of TOSHIBA CORPORATION or others.
- The information contained herein is subject to change without notice.

**DC ELECTRICAL CHARACTERISTICS**

PARAMETER	SYMBOL	TEST CONDITION		V <sub>CC</sub> (V)	Ta = 25°C			Ta = -40~85°C		UNIT
					MIN.	TYP.	MAX.	MIN.	MAX.	
High - Level Input Voltage	V <sub>IH</sub>			4.5 } 5.5	2.0	—	—	2.0	—	V
Low - Level Input Voltage	V <sub>IL</sub>			4.5 } 5.5	—	—	0.8	—	0.8	V
High - Level Output Voltage	V <sub>OH</sub>	V <sub>IN</sub> = V <sub>IH</sub> or V <sub>IL</sub>	I <sub>OH</sub> = -50μA I <sub>OH</sub> = -24mA I <sub>OH</sub> = -75mA*	4.5 4.5 5.5	4.4 3.94 —	4.5 — —	— — —	4.4 3.80 3.85	— — —	V
Low - Level Output Voltage	V <sub>OL</sub>	V <sub>IN</sub> = V <sub>IH</sub> or V <sub>IL</sub>	I <sub>OL</sub> = 50μA I <sub>OL</sub> = 24mA I <sub>OL</sub> = 75mA*	4.5 4.5 5.5	— — —	0.0 — —	0.1 0.36 —	— — —	0.1 0.44 1.65	V
Input Leakage Current	I <sub>IN</sub>	V <sub>IN</sub> = V <sub>CC</sub> or GND		5.5	—	—	±0.1	—	±1.0	μA
Quiescent Supply Current	I <sub>CC</sub>	V <sub>IN</sub> = V <sub>CC</sub> or GND		5.5	—	—	8.0	—	80.0	
	I <sub>C</sub>	PER INPUT : V <sub>IN</sub> = 3.4V OTHER INPUT : V <sub>CC</sub> or GND		5.5	—	—	1.35	—	1.5	mA

\* : This spec indicates the capability of driving 50Ω transmission lines.  
One output should be tested at a time for a 10ms maximum duration.

**AC ELECTRICAL CHARACTERISTICS ( C<sub>L</sub> = 50pF , R<sub>L</sub> = 500Ω , Input t<sub>r</sub> = t<sub>f</sub> = 3ns )**

PARAMETER	SYMBOL	TEST CONDITION		V <sub>CC</sub> (V)	Ta = 25°C			Ta = -40~85°C		UNIT
					MIN.	TYP.	MAX.	MIN.	MAX.	
Propagation Delay Time ( A , B - Y )	t <sub>pLH</sub> t <sub>pHL</sub>			5.0 ± 0.5	—	5.5	8.0	1.0	9.1	ns
Propagation Delay Time ( SELECT - Y )	t <sub>pLH</sub> t <sub>pHL</sub>			5.0 ± 0.5	—	6.9	11.4	1.0	13.0	
Propagation Delay Time ( $\overline{ST}$ - Y )	t <sub>pLH</sub> t <sub>pHL</sub>			5.0 ± 0.5	—	6.8	10.8	1.0	12.3	
Input Capacitance	C <sub>IN</sub>				—	5	10	—	10	pF
Power Dissipation Capacitance	C <sub>PD</sub>				—	51	—	—	—	

Note (1) C<sub>PD</sub> is defined as the value of the internal equivalent capacitance which is calculated from the operating current consumption without load.

Average operating current can be obtained by the equation :

$$I_{CC(opr.)} = C_{PD} \cdot V_{CC} \cdot f_{IN} + I_{CC} / 4 \text{ (per bit)}$$

**DIP 16PIN OUTLINE DRAWING (DIP16-P-300-2.54A)**

Unit in mm

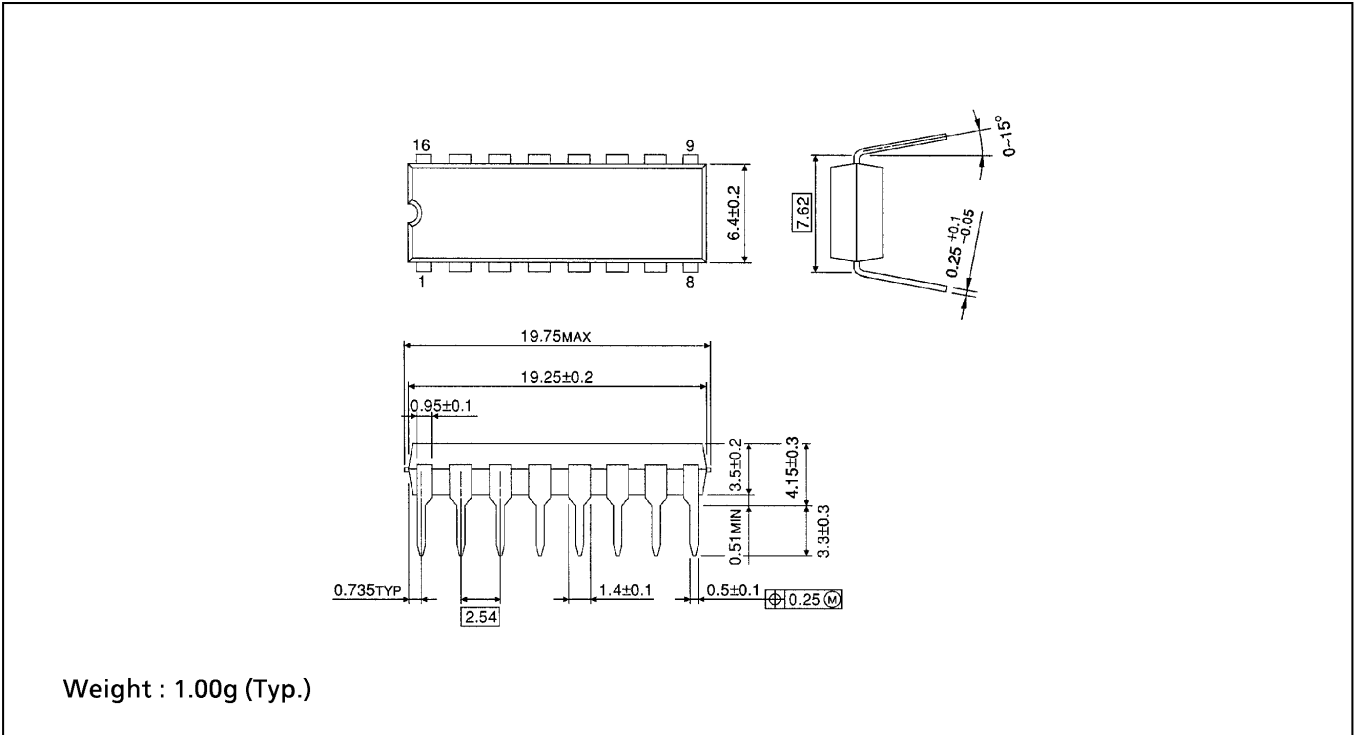

**SOP 16PIN (200mil BODY) OUTLINE DRAWING (SOP16-P-300-1.27)**

Unit in mm

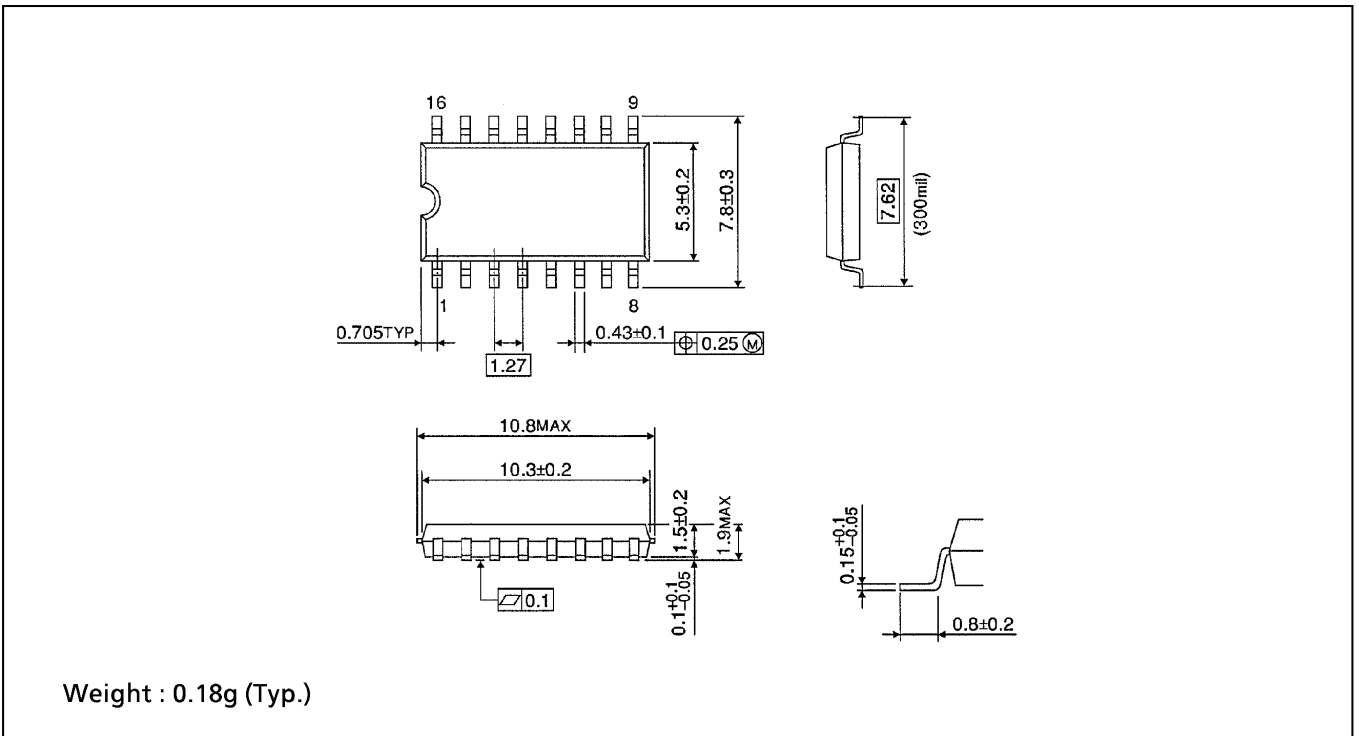

**SOP 16PIN (150mil BODY) OUTLINE DRAWING (SOL16-P-150 -1.27)**

Unit in mm

(Note) This package is not available in Japan.

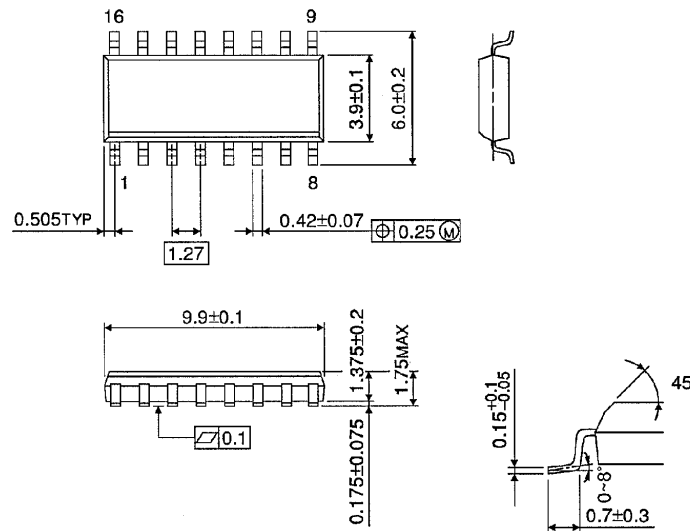

Weight : 0.13g (Typ.)

**TSSOP 16PIN OUTLINE DRAWING (TSSOP16-P-0044-0.65)**

Unit in mm

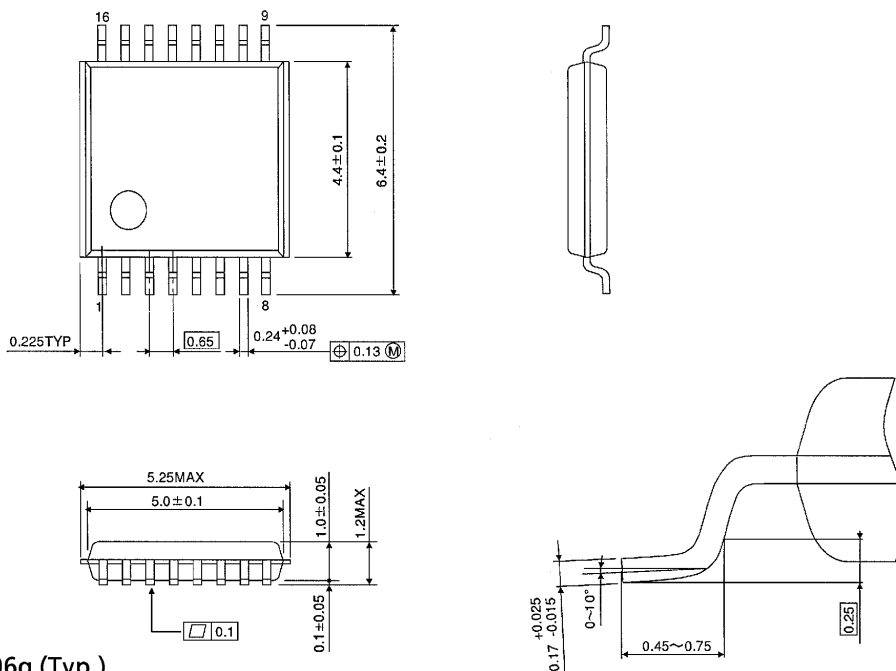

Weight : 0.06g (Typ.)