

# SN74LS85

## 4-Bit Magnitude Comparator

The SN74LS85 is a 4-Bit Magnitude Comparator which compares two 4-bit words (A, B), each word having four Parallel Inputs ( $A_0$ – $A_3$ ,  $B_0$ – $B_3$ );  $A_3$ ,  $B_3$  being the most significant inputs. Operation is not restricted to binary codes, the device will work with any monotonic code. Three Outputs are provided: “A greater than B” ( $O_{A>B}$ ), “A less than B” ( $O_{A<B}$ ), “A equal to B” ( $O_{A=B}$ ). Three Expander Inputs,  $I_{A>B}$ ,  $I_{A<B}$ ,  $I_{A=B}$ , allow cascading without external gates. For proper compare operation, the Expander Inputs to the least significant position must be connected as follows:  $I_{A<B} = I_{A>B} = L$ ,  $I_{A=B} = H$ . For serial (ripple) expansion, the  $O_{A>B}$ ,  $O_{A<B}$  and  $O_{A=B}$  Outputs are connected respectively to the  $I_{A>B}$ ,  $I_{A<B}$ , and  $I_{A=B}$  Inputs of the next most significant comparator, as shown in Figure 1. Refer to Applications section of data sheet for high speed method of comparing large words.

The Truth Table on the following page describes the operation of the SN74LS85 under all possible logic conditions. The upper 11 lines describe the normal operation under all conditions that will occur in a single device or in a series expansion scheme. The lower five lines describe the operation under abnormal conditions on the cascading inputs. These conditions occur when the parallel expansion technique is used.

- Easily Expandable
- Binary or BCD Comparison
- $O_{A>B}$ ,  $O_{A<B}$ , and  $O_{A=B}$  Outputs Available

### GUARANTEED OPERATING RANGES

Symbol	Parameter	Min	Typ	Max	Unit
$V_{CC}$	Supply Voltage	4.75	5.0	5.25	V
$T_A$	Operating Ambient Temperature Range	0	25	70	°C
$I_{OH}$	Output Current – High			–0.4	mA
$I_{OL}$	Output Current – Low			8.0	mA



**ON Semiconductor**  
Formerly a Division of Motorola  
<http://onsemi.com>

### LOW POWER SCHOTTKY

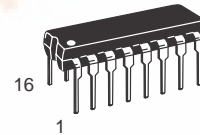

PLASTIC N SUFFIX CASE 648

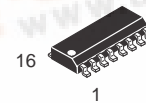

SOIC D SUFFIX CASE 751B

### ORDERING INFORMATION

Device	Package	Shipping
SN74LS85N	16 Pin DIP	2000 Units/Box
SN74LS85D	16 Pin	2500/Tape & Reel



# SN74LS85

## CONNECTION DIAGRAM DIP (TOP VIEW)

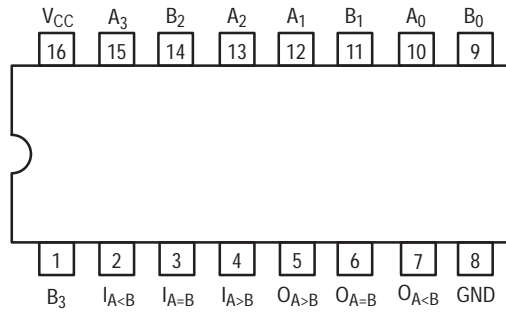

NOTE:  
The Flatpak version has the same pinouts (Connection Diagram) as the Dual In-Line Package.

PIN NAMES		LOADING (Note a)	
		HIGH	LOW
$A_0 - A_3, B_0 - B_3$	Parallel Inputs	1.5 U.L.	0.75 U.L.
$I_{A=B}$	A = B Expander Inputs	1.5 U.L.	0.75 U.L.
$I_{A < B}, I_{A > B}$	A < B, A > B, Expander Inputs	0.5 U.L.	0.25 U.L.
$O_{A > B}$	A Greater than B Output	10 U.L.	5 U.L.
$O_{A < B}$	B Greater than A Output	10 U.L.	5 U.L.
$O_{A = B}$	A Equal to B Output	10 U.L.	5 U.L.

### NOTES:

a) 1 TTL Unit Load (U.L.) = 40  $\mu$ A HIGH/1.6 mA LOW.

## LOGIC SYMBOL

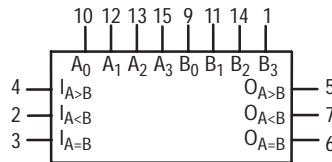

$V_{CC}$  = PIN 16  
GND = PIN 8

# SN74LS85

## LOGIC DIAGRAM

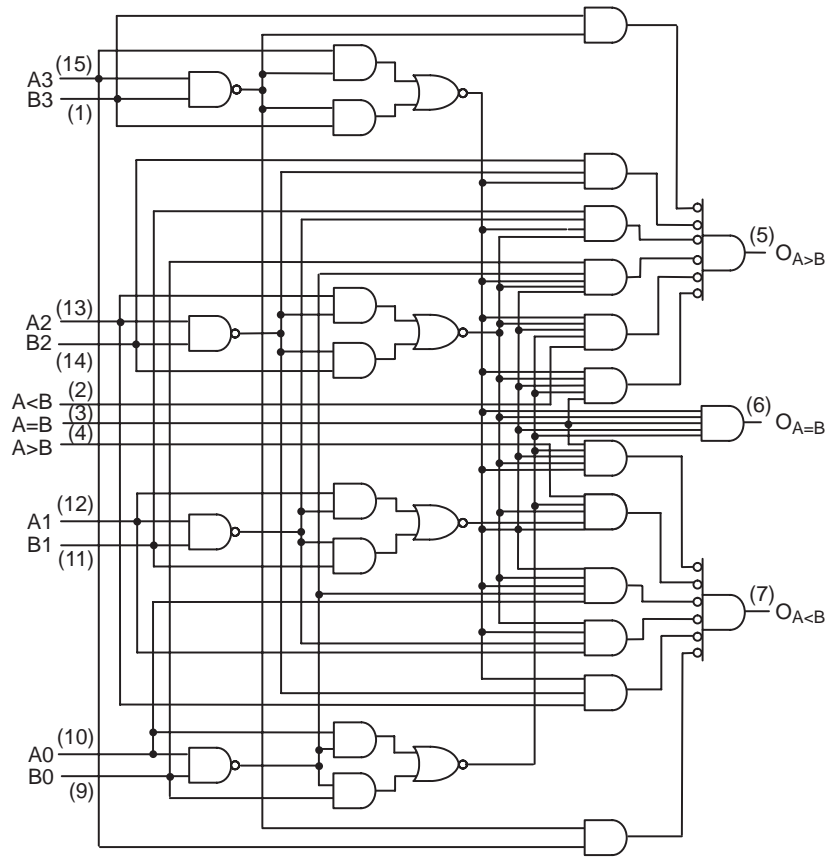

## TRUTH TABLE

COMPARING INPUTS				CASCADING INPUTS			OUTPUTS		
A <sub>3</sub> ,B <sub>3</sub>	A <sub>2</sub> ,B <sub>2</sub>	A <sub>1</sub> ,B <sub>1</sub>	A <sub>0</sub> ,B <sub>0</sub>	I <sub>A&gt;B</sub>	I <sub>A&lt;B</sub>	I <sub>A=B</sub>	O <sub>A&gt;B</sub>	O <sub>A&lt;B</sub>	O <sub>A=B</sub>
A <sub>3</sub> >B <sub>3</sub>	X	X	X	X	X	X	H	L	L
A <sub>3</sub> <B <sub>3</sub>	X	X	X	X	X	X	L	H	L
A <sub>3</sub> =B <sub>3</sub>	A <sub>2</sub> >B <sub>2</sub>	X	X	X	X	X	H	L	L
A <sub>3</sub> =B <sub>3</sub>	A <sub>2</sub> <B <sub>2</sub>	X	X	X	X	X	L	H	L
A <sub>3</sub> =B <sub>3</sub>	A <sub>2</sub> =B <sub>2</sub>	A <sub>1</sub> >B <sub>1</sub>	X	X	X	X	H	L	L
A <sub>3</sub> =B <sub>3</sub>	A <sub>2</sub> =B <sub>2</sub>	A <sub>1</sub> <B <sub>1</sub>	X	X	X	X	L	H	L
A <sub>3</sub> =B <sub>3</sub>	A <sub>2</sub> =B <sub>2</sub>	A <sub>1</sub> =B <sub>1</sub>	A <sub>0</sub> >B <sub>0</sub>	X	X	X	H	L	L
A <sub>3</sub> =B <sub>3</sub>	A <sub>2</sub> =B <sub>2</sub>	A <sub>1</sub> =B <sub>1</sub>	A <sub>0</sub> <B <sub>0</sub>	X	X	X	L	H	L
A <sub>3</sub> =B <sub>3</sub>	A <sub>2</sub> =B <sub>2</sub>	A <sub>1</sub> =B <sub>1</sub>	A <sub>0</sub> =B <sub>0</sub>	H	L	L	H	L	L
A <sub>3</sub> =B <sub>3</sub>	A <sub>2</sub> =B <sub>2</sub>	A <sub>1</sub> =B <sub>1</sub>	A <sub>0</sub> =B <sub>0</sub>	L	H	L	L	H	L
A <sub>3</sub> =B <sub>3</sub>	A <sub>2</sub> =B <sub>2</sub>	A <sub>1</sub> =B <sub>1</sub>	A <sub>0</sub> =B <sub>0</sub>	X	X	H	L	L	H
A <sub>3</sub> =B <sub>3</sub>	A <sub>2</sub> =B <sub>2</sub>	A <sub>1</sub> =B <sub>1</sub>	A <sub>0</sub> =B <sub>0</sub>	H	H	L	L	L	L
A <sub>3</sub> =B <sub>3</sub>	A <sub>2</sub> =B <sub>2</sub>	A <sub>1</sub> =B <sub>1</sub>	A <sub>0</sub> =B <sub>0</sub>	L	L	L	H	H	L

H = HIGH Level  
L = LOW Level  
X = IMMATERIAL

# SN74LS85

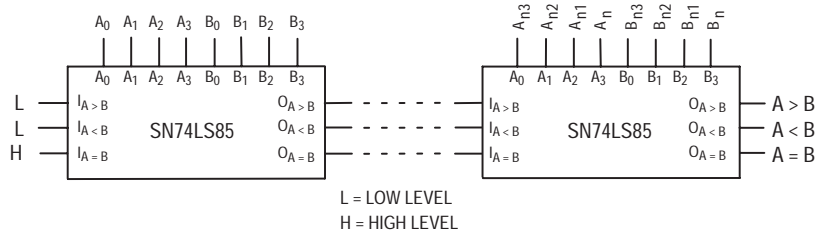

Figure 1. Comparing Two n-Bit Words

## APPLICATIONS

Figure 2 shows a high speed method of comparing two 24-bit words with only two levels of device delay. With the technique shown in Figure 1, six levels of device delay result

when comparing two 24-bit words. The parallel technique can be expanded to any number of bits, see Table 1.

Table 1

WORD LENGTH	NUMBER OF PKGS.
1-4 Bits	1
5-24 Bits	2-6
25-120 Bits	8-31

NOTE:

The SN74LS85 can be used as a 5-bit comparator only when the outputs are used to drive the A<sub>0</sub>-A<sub>3</sub> and B<sub>0</sub>-B<sub>3</sub> inputs of another SN74LS85 as shown in Figure 2 in positions #1, 2, 3, and 4.

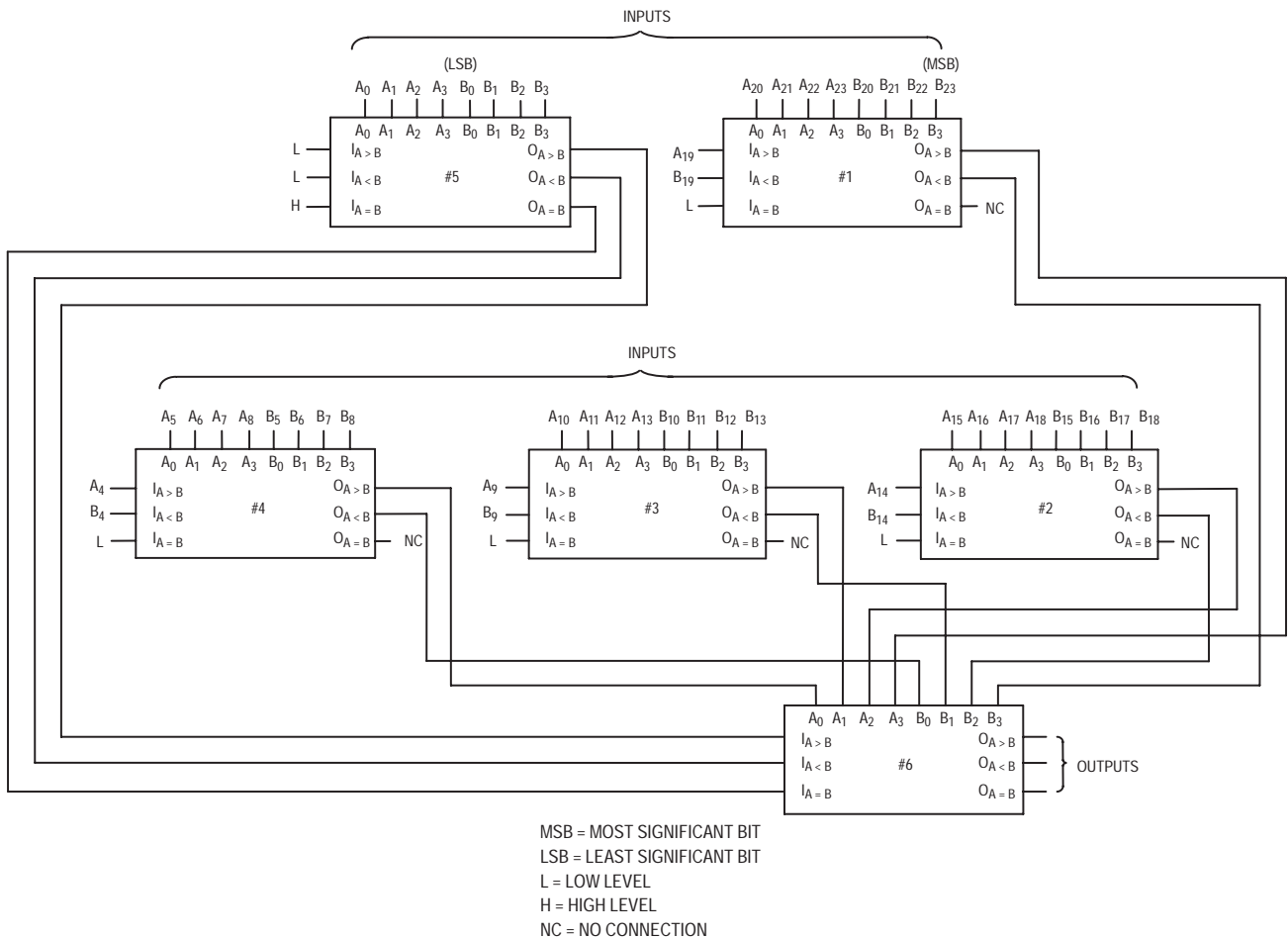

Figure 2. Comparison of Two 24-Bit Words

# SN74LS85

## DC CHARACTERISTICS OVER OPERATING TEMPERATURE RANGE (unless otherwise specified)

Symbol	Parameter	Limits			Unit	Test Conditions
		Min	Typ	Max		
$V_{IH}$	Input HIGH Voltage	2.0			V	Guaranteed Input HIGH Voltage for All Inputs
$V_{IL}$	Input LOW Voltage			0.8	V	Guaranteed Input LOW Voltage for All Inputs
$V_{IK}$	Input Clamp Diode Voltage		-0.65	-1.5	V	$V_{CC} = \text{MIN}$ , $I_{IN} = -18 \text{ mA}$
$V_{OH}$	Output HIGH Voltage	2.7	3.5		V	$V_{CC} = \text{MIN}$ , $I_{OH} = \text{MAX}$ , $V_{IN} = V_{IH}$ or $V_{IL}$ per Truth Table
$V_{OL}$	Output LOW Voltage		0.25	0.4	V	$I_{OL} = 4.0 \text{ mA}$
			0.35	0.5	V	$I_{OL} = 8.0 \text{ mA}$
$I_{IH}$	Input HIGH Current A < B, A > B Other Inputs			20 60	$\mu\text{A}$	$V_{CC} = \text{MAX}$ , $V_{IN} = 2.7 \text{ V}$
	A < B, A > B Other Inputs			0.1 0.3	mA	$V_{CC} = \text{MAX}$ , $V_{IN} = 7.0 \text{ V}$
$I_{IL}$	Input LOW Current A < B, A > B Other Inputs			-0.4 -1.2	mA	$V_{CC} = \text{MAX}$ , $V_{IN} = 0.4 \text{ V}$
$I_{OS}$	Output Short Circuit Current (Note 1)	-20		-100	mA	$V_{CC} = \text{MAX}$
$I_{CC}$	Power Supply Current			20	mA	$V_{CC} = \text{MAX}$

Note 1: Not more than one output should be shorted at a time, nor for more than 1 second.

## AC CHARACTERISTICS ( $T_A = 25^\circ\text{C}$ , $V_{CC} = 5.0 \text{ V}$ )

Symbol	Parameter	Limits			Unit	Test Conditions
		Min	Typ	Max		
$t_{PLH}$ $t_{PHL}$	Any A or B to A < B, A > B		24 20	36 30	ns	$V_{CC} = 5.0 \text{ V}$ $C_L = 15 \text{ pF}$
$t_{PLH}$ $t_{PHL}$	Any A or B to A = B		27 23	45 45	ns	
$t_{PLH}$ $t_{PHL}$	A < B or A = B to A > B		14 11	22 17	ns	
$t_{PLH}$ $t_{PHL}$	A = B to A = B		13 13	20 26	ns	
$t_{PLH}$ $t_{PHL}$	A > B or A = B to A < B		14 11	22 17	ns	

## AC WAVEFORMS

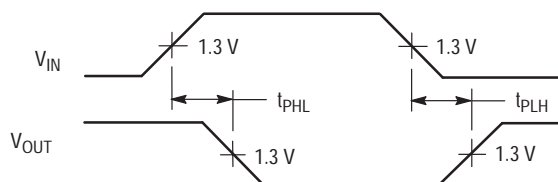

Figure 3.

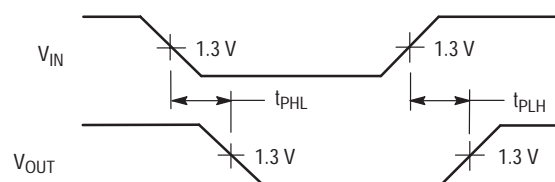
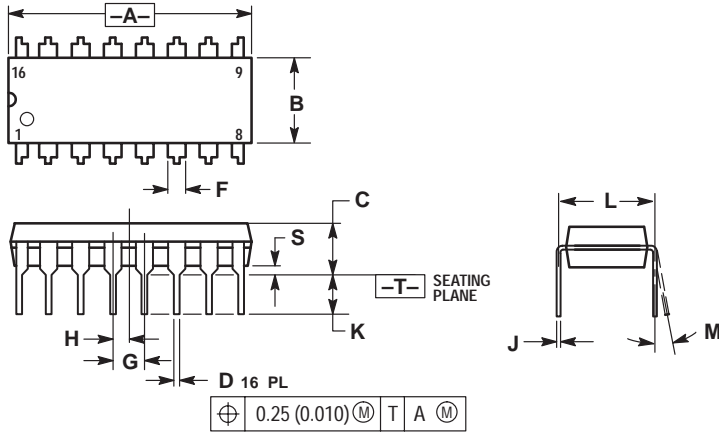

Figure 4.

# SN74LS85

## PACKAGE DIMENSIONS

**N SUFFIX**  
**PLASTIC PACKAGE**  
**CASE 648-08**  
**ISSUE R**



**NOTES:**

1. DIMENSIONING AND TOLERANCING PER ANSI Y14.5M, 1982.
2. CONTROLLING DIMENSION: INCH.
3. DIMENSION L TO CENTER OF LEADS WHEN FORMED PARALLEL.
4. DIMENSION B DOES NOT INCLUDE MOLD FLASH.
5. ROUNDED CORNERS OPTIONAL.

DIM	INCHES		MILLIMETERS	
	MIN	MAX	MIN	MAX
A	0.740	0.770	18.80	19.55
B	0.250	0.270	6.35	6.85
C	0.145	0.175	3.69	4.44
D	0.015	0.021	0.39	0.53
F	0.040	0.70	1.02	1.77
G	0.100 BSC		2.54 BSC	
H	0.050 BSC		1.27 BSC	
J	0.008	0.015	0.21	0.38
K	0.110	0.130	2.80	3.30
L	0.295	0.305	7.50	7.74
M	0°	10°	0°	10°
S	0.020	0.040	0.51	1.01

# SN74LS85

## PACKAGE DIMENSIONS

**D SUFFIX**  
**PLASTIC SOIC PACKAGE**  
**CASE 751B-05**  
**ISSUE J**

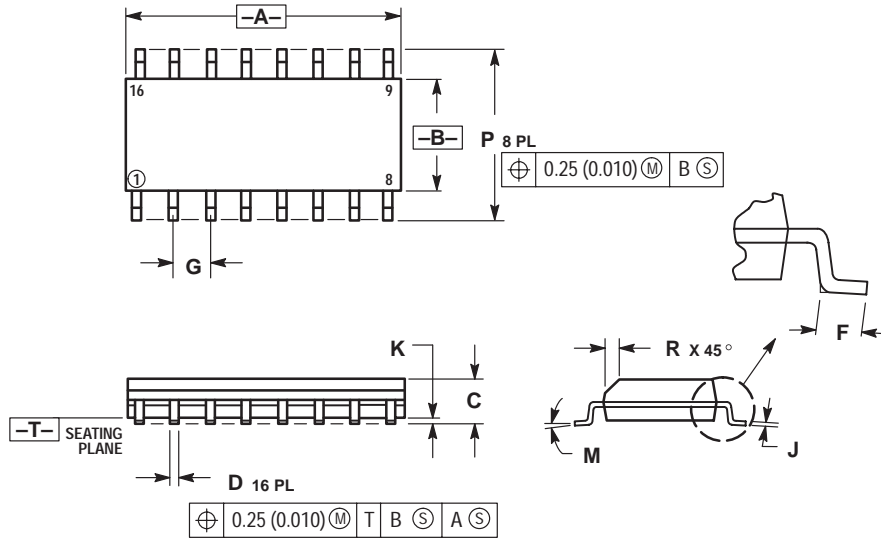

**NOTES:**

1. DIMENSIONING AND TOLERANCING PER ANSI Y14.5M, 1982.
2. CONTROLLING DIMENSION: MILLIMETER.
3. DIMENSIONS A AND B DO NOT INCLUDE MOLD PROTRUSION.
4. MAXIMUM MOLD PROTRUSION 0.15 (0.006) PER SIDE.
5. DIMENSION D DOES NOT INCLUDE DAMBAR PROTRUSION. ALLOWABLE DAMBAR PROTRUSION SHALL BE 0.127 (0.005) TOTAL IN EXCESS OF THE D DIMENSION AT MAXIMUM MATERIAL CONDITION.

DIM	MILLIMETERS		INCHES	
	MIN	MAX	MIN	MAX
A	9.80	10.00	0.386	0.393
B	3.80	4.00	0.150	0.157
C	1.35	1.75	0.054	0.068
D	0.35	0.49	0.014	0.019
F	0.40	1.25	0.016	0.049
G	1.27 BSC		0.050 BSC	
J	0.19	0.25	0.008	0.009
K	0.10	0.25	0.004	0.009
M	0°	7°	0°	7°
P	5.80	6.20	0.229	0.244
R	0.25	0.50	0.010	0.019

# SN74LS85

**ON Semiconductor** and  are trademarks of Semiconductor Components Industries, LLC (SCILLC). SCILLC reserves the right to make changes without further notice to any products herein. SCILLC makes no warranty, representation or guarantee regarding the suitability of its products for any particular purpose, nor does SCILLC assume any liability arising out of the application or use of any product or circuit, and specifically disclaims any and all liability, including without limitation special, consequential or incidental damages. "Typical" parameters which may be provided in SCILLC data sheets and/or specifications can and do vary in different applications and actual performance may vary over time. All operating parameters, including "Typicals" must be validated for each customer application by customer's technical experts. SCILLC does not convey any license under its patent rights nor the rights of others. SCILLC products are not designed, intended, or authorized for use as components in systems intended for surgical implant into the body, or other applications intended to support or sustain life, or for any other application in which the failure of the SCILLC product could create a situation where personal injury or death may occur. Should Buyer purchase or use SCILLC products for any such unintended or unauthorized application, Buyer shall indemnify and hold SCILLC and its officers, employees, subsidiaries, affiliates, and distributors harmless against all claims, costs, damages, and expenses, and reasonable attorney fees arising out of, directly or indirectly, any claim of personal injury or death associated with such unintended or unauthorized use, even if such claim alleges that SCILLC was negligent regarding the design or manufacture of the part. SCILLC is an Equal Opportunity/Affirmative Action Employer.

## PUBLICATION ORDERING INFORMATION

### North America Literature Fulfillment:

Literature Distribution Center for ON Semiconductor  
P.O. Box 5163, Denver, Colorado 80217 USA  
**Phone:** 303-675-2175 or 800-344-3860 Toll Free USA/Canada  
**Fax:** 303-675-2176 or 800-344-3867 Toll Free USA/Canada  
**Email:** ONlit@hibbertco.com

**N. American Technical Support:** 800-282-9855 Toll Free USA/Canada

**EUROPE:** LDC for ON Semiconductor – European Support

**German Phone:** (+1) 303-308-7140 (M-F 2:30pm to 5:00pm Munich Time)  
**Email:** ONlit-german@hibbertco.com  
**French Phone:** (+1) 303-308-7141 (M-F 2:30pm to 5:00pm Toulouse Time)  
**Email:** ONlit-french@hibbertco.com  
**English Phone:** (+1) 303-308-7142 (M-F 1:30pm to 5:00pm UK Time)  
**Email:** ONlit@hibbertco.com

**ASIA/PACIFIC:** LDC for ON Semiconductor – Asia Support

**Phone:** 303-675-2121 (Tue-Fri 9:00am to 1:00pm, Hong Kong Time)  
Toll Free from Hong Kong 800-4422-3781  
**Email:** ONlit-asia@hibbertco.com

**JAPAN:** ON Semiconductor, Japan Customer Focus Center  
4-32-1 Nishi-Gotanda, Shinagawa-ku, Tokyo, Japan 141-8549

**Phone:** 81-3-5487-8345  
**Email:** r14153@onsemi.com

**Fax Response Line:** 303-675-2167  
800-344-3810 Toll Free USA/Canada

**ON Semiconductor Website:** <http://onsemi.com>

For additional information, please contact your local Sales Representative.