

International IOR Rectifier

S1234

PHASE CONTROL THYRISTORS

- Junction Size : Square 480 mils - IR480SG12H/ S1234
- Wafer Size : 4"
- V_{RRM}/V_{DRM} Class : 600 to 1200 V
- Passivation Process : Glassivated MESA
- Reference IR Packaged Part : T90RIA Series

Major Ratings and Characteristics

Parameters	Units	Test Conditions
V_{TM} Typical On-state Voltage	1.2 V	$T_J = 25^\circ\text{C}$, $I_T = 25\text{ A}$
V_{RRM}/V_{DRM} Reverse Breakdown Voltage	600 to 1200 V	$T_J = 25^\circ\text{C}$, $I_{RRM} = 100\ \mu\text{A}$ (1)
I_{GT} Required DC Gate Current to Trigger	10 to 110 mA	$T_J = 25^\circ\text{C}$, anode supply = 6 V, resistive load
V_{GT} Max. Required DC Gate Voltage to Trigger	1.9 V	$T_J = 25^\circ\text{C}$, anode supply = 6 V, resistive load
I_H Holding Current Range	10 to 200 mA	Anode supply = 6 V, resistive load
I_L Maximum Latching Current	400 mA	Anode supply = 6 V, resistive load

(1) Nitrogen flow on die edge.

Mechanical Characteristics

Nominal Back Metal Composition, Thickness	Cr - Ni - Ag (1 KA - 4 KA - 15 KA)
Nominal Front Metal Composition, Thickness	Cr - Ni - Ag (1 KA - 4 KA - 15 KA)
Chip Dimensions	480 x 480 mils (see drawing)
Wafer Diameter	100 mm, with std. <100> flat
Wafer Thickness	370 $\mu\text{m} \pm 10\ \mu\text{m}$
Maximum Width of Sawing Line	130 μm
Reject Ink Dot Size	0.25 mm diameter minimum
Ink Dot Location	See drawing
Recommended Storage Environment	Storage in original container, in dessicated nitrogen, with no contamination



S1234

Bulletin I0140J 01/01

International
IRF Rectifier

Outline Table

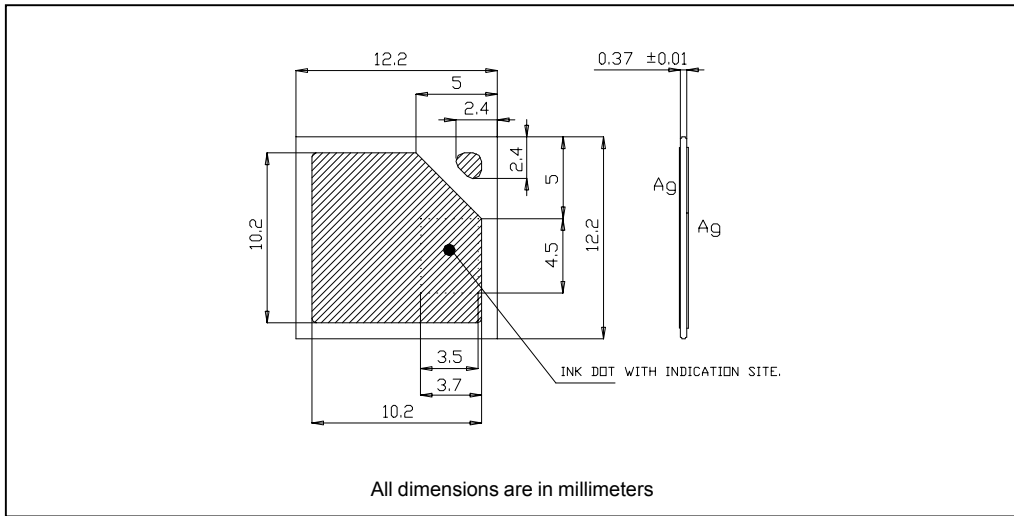

Wafer Layout

