



MAX3691 Evaluation Kit

General Description

The MAX3691 evaluation kit (EV kit) simplifies evaluation of the MAX3691 622Mbps, SDH/SONET 4:1 serializer. This EV kit requires a single +3.3V supply and includes the external components necessary to observe the PECL serial-data output on a 50Ω input oscilloscope.

The serial-data output termination can be modified easily to suit other logic interfaces, such as 3.3V PECL, high impedance, or ECL inputs. To evaluate the MAX3691's basic functioning, connect the board directly to the outputs of an LVDS device (such as an overhead-generation circuit) or to a signal generator.

Component List

DESIGNATION	QTY	DESCRIPTION
C1	1	33μF, 16V tantalum capacitor AVX TAJC336M016 or Sprague 293D336X0016D
C2	1	1μF ceramic capacitor
C3, C5, C7, C10, C12, C15, C18, C19, C20	9	0.1μF ceramic capacitors
C4, C6, C8, C9, C11, C13, C14, C16	8	100pF ceramic capacitors
JP1	1	2-pin header (0.1" centers)
L1, L3, C17	3	0Ω resistors
L2, L4, L5	3	56nH inductors Coilcraft 0805HS-560TKBC
R1	1	1.5Ω 1% resistor
R2, R6	2	24Ω 5% resistors
R3, R7	2	27Ω 5% resistors
R4, R8	2	130Ω 5% resistors
R5, R9	2	220Ω 5% resistors
R10	1	24.9kΩ 1% resistor
RCLK+, RCLK-, PCLKI+, PCLKI-, PD0+, PD0-, PD1+, PD1-, PD2+, PD2-, PD3+, PD3-, SDO+, SDO-, PCLKO+, PCLKO-	16	SMA PC edge-mount connectors
U1	1	MAX3691ECJ 32-pin TQFP
None	1	MAX3691 data sheet

Features

- ◆ Single +3.3V Supply
- ◆ Output Terminated for Interfacing with a 50Ω Oscilloscope Input
- ◆ Fully Tested and Assembled

Ordering Information

PART	TEMP. RANGE	BOARD TYPE
MAX3691EVKIT-SO	-40°C to +85°C	Surface Mount

Component Suppliers

SUPPLIER	PHONE	FAX
AVX	803-946-0690	803-626-3123
Coilcraft	847-639-6400	847-639-1469
Sprague	603-224-1961	603-224-1430

Note: Please indicate that you are using the MAX3691 when contacting these component suppliers.

Evaluates: MAX3691



MAX3691 Evaluation Kit

Detailed Description

The MAX3691 evaluation kit (EV kit) operates from a single +3.3V supply and includes the external components necessary to observe the PECL serial-data output on a 50Ω input oscilloscope.

Each MAX3691 LVDS input (PCLKI+, PCLKI-, RCLK+, RCLK-, PD_+, and PD_-) is internally terminated with a 100Ω differential input resistance. Ensure that LVDS devices driving these inputs are not redundantly terminated.

LVDS parallel-clock outputs (PCLKO+, PCLKO-) must be differentially terminated with 100Ω. When terminating these outputs into 50Ω loads, use AC coupling (see the section *Connecting Parallel-Clock LVDS Outputs to 50Ω Input Oscilloscopes*).

The EV kit serial-data output (SDO+, SDO-) termination network allows the outputs to be connected directly to a high-speed oscilloscope's 50Ω input. This termination provides the serial data outputs with a Thevenin equivalent of 50Ω to V_{CC} - 2V when connected to a 50Ω load. This provides a 2-times output signal attenuation. If only one of the serial data outputs is connected to an oscilloscope, ensure that the other is still properly terminated. Keep in mind that the resistor networks at each output provide proper termination only when they are terminated through 50Ω to ground. See the *Alternative PECL Output Termination* section for other logic interfaces.

Table 1. Jumpers and Test Points

NAME	TYPE	DESCRIPTION	NORMAL POSITION
JP1	2 pin	Disables the loop filter	Open
JP3–JP7	2 pin	Jumper locations (can be cut open if necessary)	Shorted

Applications Information

Alternative PECL Output Termination

Alternative PECL output termination methods can be used for different logic interfaces as long as they provide a DC Thevenin equivalent of 50Ω to V_{CC} - 2V. For example, to interface SDO+ with a PECL or high-impedance input, short resistors R2 and R3, and replace R5 with an 82Ω resistor. To interface SDO+ with ECL input test equipment, which is internally terminated with 50Ω to -2V, take the following steps:

- 1) Remove R4 and R5.
- 2) Short R2 and R3.
- 3) Place a bias-T in series between the MAX3691 and the test equipment. Connect the bias-T's RF and DC terminals to the SDO+ output and the RF terminal to the test equipment's ECL input. Then connect the DC terminal to a V_{CC} - 2V termination voltage through a 50Ω resistor.

Connecting Parallel-Clock LVDS Outputs to 50Ω Input Oscilloscopes

To monitor the parallel-clock LVDS signals (PCLKO+, PCLKO-) on a 50Ω input oscilloscope, place a capacitor or DC block in series with each output and the instrument input. **Do not connect MAX3691 outputs directly to 50Ω inputs or terminations to ground.** Choose a coupling capacitor (0.1μF recommended) large enough in value to prevent pattern-dependent distortion of the output signal.

MAX3691 Evaluation Kit

Evaluates: MAX3691

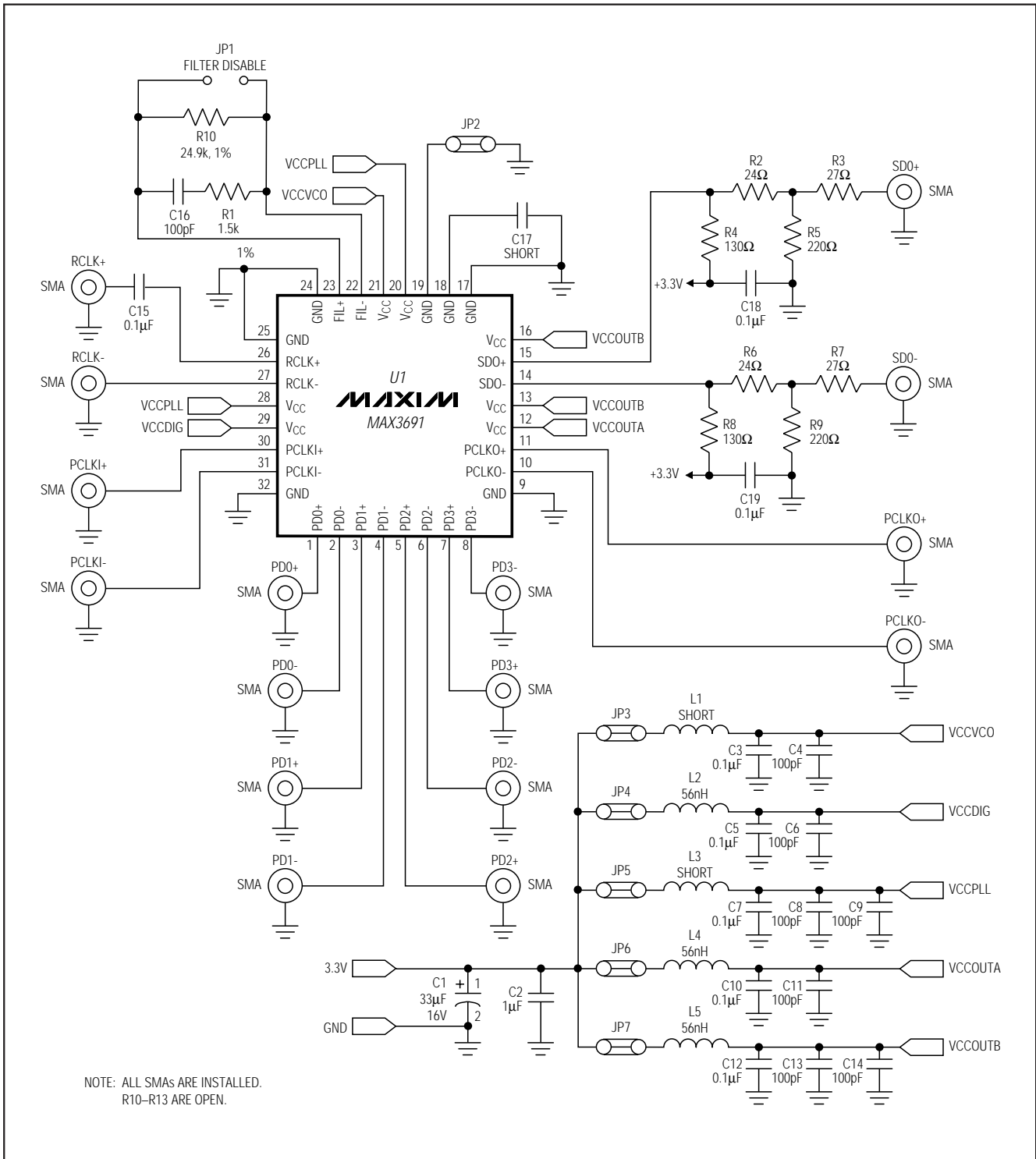

Figure 1. MAX3691 EV Kit Schematic

MAX3691 Evaluation Kit

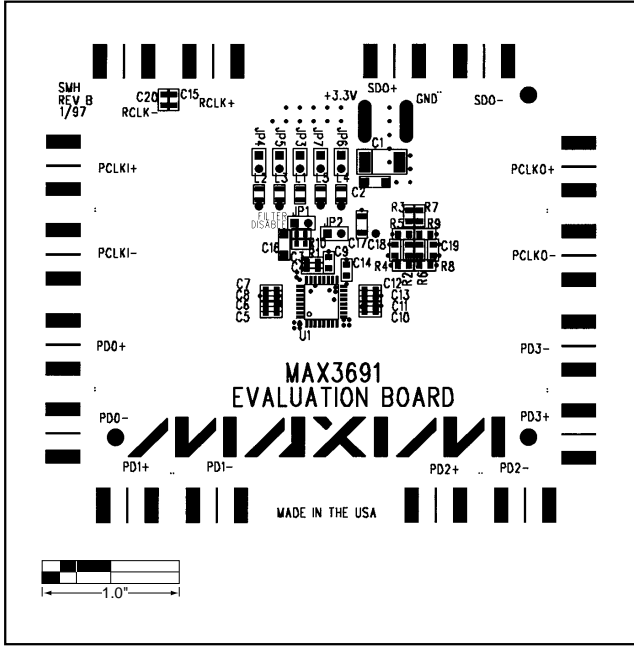

Figure 2. MAX3691 EV Kit Component Placement Guide—Top Silk Screen

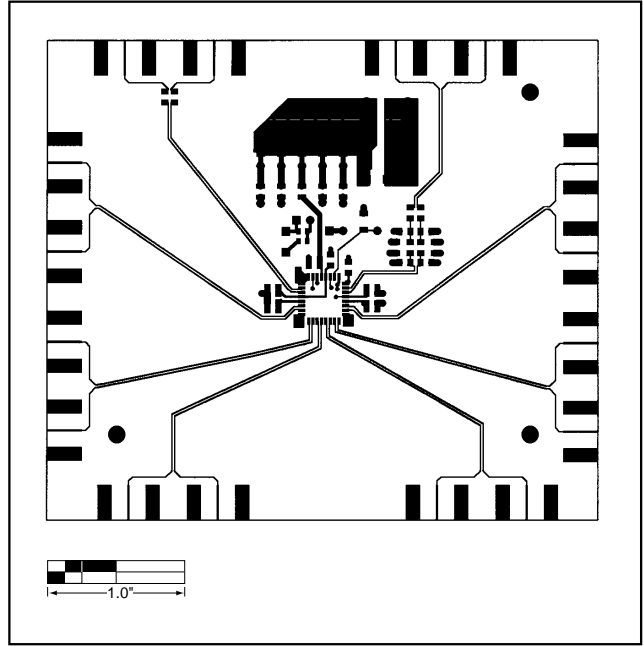

Figure 3. MAX3691 EV Kit PC Board Layout—Component Side

MAX3691 Evaluation Kit

Evaluates: MAX3691

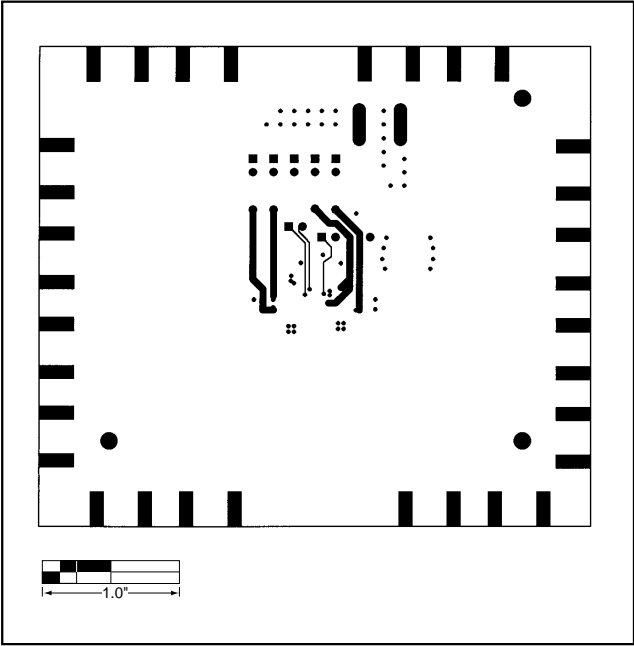

Figure 4. MAX3691 EV Kit PC Board Layout—Solder Side

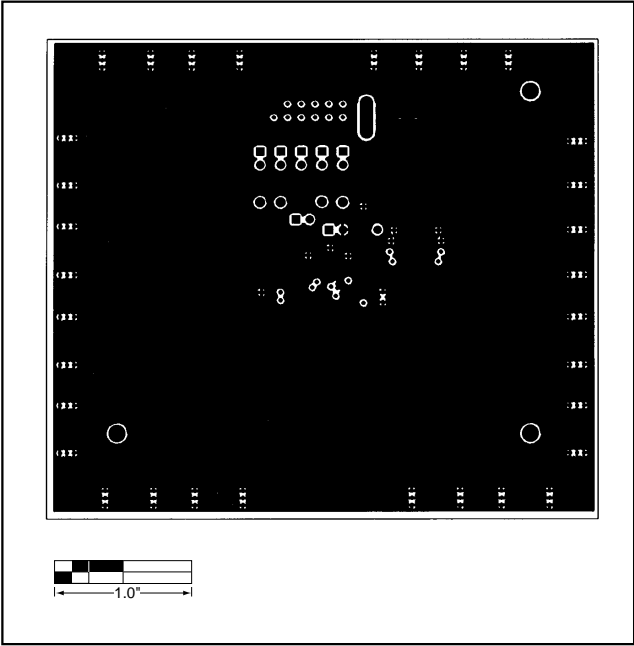

Figure 5. MAX3691 EV Kit PC Board Layout—GND Plane

MAX3691 Evaluation Kit

Evaluates: MAX3691

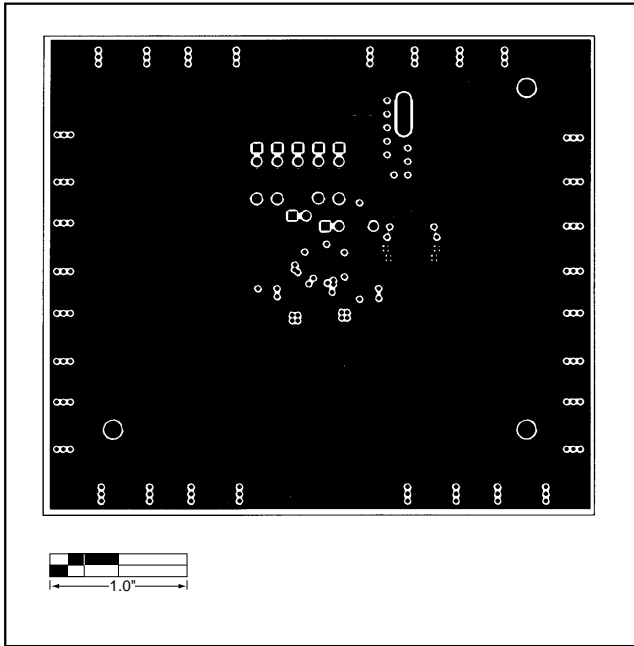

Figure 6. MAX3691 EV Kit PC Board Layout—Power Plane

Maxim cannot assume responsibility for use of any circuitry other than circuitry entirely embodied in a Maxim product. No circuit patent licenses are implied. Maxim reserves the right to change the circuitry and specifications without notice at any time.

6 Maxim Integrated Products, 120 San Gabriel Drive, Sunnyvale, CA 94086 408-737-7600

© 1999 Maxim Integrated Products

Printed USA

MAXIM is a registered trademark of Maxim Integrated Products.