

# MAXIM

## MAX1819 Evaluation Kit

### General Description

The MAX1819 linear regulator evaluation kit (EV kit) provides a regulated 1.8V output voltage from a 2.5V to 5.5V input source. It delivers up to 500mA output current.

The EV kit is a fully assembled and tested surface-mount PC board. It can also evaluate other output voltages in the 1.25V to 5.0V range by using external resistors.

### Component List

DESIGNATION	QTY	DESCRIPTION
C1	1	1 $\mu$ F $\pm$ 10%, 10V X7R ceramic capacitor (0805) Taiyo Yuden LMK212BJ105KG or Murata GRM40X7R105K010AD
C2	1	4.7 $\mu$ F $\pm$ 20%, 6.3V X5R ceramic capacitor (0805) Taiyo Yuden JMK212BJ475MG or TDK C2012X5R0J475M
JU1	1	3-pin header
R1	0	Not installed (0603)
R2	0	Not installed, pads shorted with PC trace (0603)
R3	1	100k $\Omega$ $\pm$ 5% resistor (0603)
U1	1	MAX1819EBL18 (6-bump UCSP) Top mark AAG
None	1	Shunt
None	1	MAX1819 PC board
None	1	MAX1819EVKIT data sheet
None	1	MAX1819 data sheet

### Features

- ◆ 2.5V to 5.5V Input Voltage Range
- ◆ Up to 500mA Output Current
- ◆ Output Voltage
  - 1.8V Fixed Output Voltage (MAX1819EBL18)
  - 1.25V to 5.0V Adjustable Output Voltage (External Divider)
- ◆ Power-OK Output
- ◆ 6-Bump UCSP Package
- ◆ Surface-Mount Construction
- ◆ Fully Assembled and Tested

### Ordering Information

PART	TEMP RANGE	IC PACKAGE
MAX1819EVKIT	0°C to +70°C	6 UCSP

**Note:** To evaluate the MAX1819EBL15/20/25/33/50, use external feedback resistors.

### Quick Start

The MAX1819 EV kit is fully assembled and tested. Follow these steps to verify board operation.

**Do not turn on the power supply until all connections are completed:**

- 1) Verify that the shunt is across pins 1 and 2 of jumper JU1 (SHDN) (Table 1).
- 2) Connect a voltmeter to the VOUT pad. Connect the ground to the GND pad closest to VOUT.
- 3) Connect a 2.5V to 5.5V supply to the VIN pad. Connect the supply ground to the GND pad closest to VIN.
- 4) Turn on the power supply and verify that the output is the preset voltage of 1.8V.

To evaluate other voltages, see the *Evaluating Other Output Voltages* section.

### Component Suppliers

SUPPLIER	PHONE	FAX	WEBSITE
Murata	770-436-1300	770-436-3030	www.murata.com
Taiyo Yuden	800-348-2496	847-925-0899	www.t-yuden.com
TDK	847-803-6100	847-390-4405	www.component.tdk.com

**Note:** Please indicate that you are using the MAX1819 when contacting these component suppliers.

Evaluates: MAX1819EBL18

# MAX1819 Evaluation Kit

## Detailed Description

The MAX1819 EV kit contains a low-dropout, linear-regulator circuit, which provides a 1.8V output from a 2.5V to 5.5V input voltage. The EV kit provides up to 500mA output current. Power-OK will provide a logical low output when the output voltage falls below 93% of its nominal voltage.

The MAX1819 EV kit features a shutdown mode that reduces quiescent current to 0.1µA (typ) to preserve the battery life.

### Evaluating Other Output Voltages

The output voltage of the MAX1819 EV kit is preset to 1.8V. To generate an output voltage other than the preset output voltage, cut open the PC trace shorting R2, and install feedback resistors R1 and R2. Select R2 in the 25kΩ to 100kΩ range, then R1 is given by:

$$V_{OUT} = V_{SET} (1 + R1 / R2)$$

$$R1 = R2 [(V_{OUT} / V_{SET}) - 1]$$

where  $V_{SET} = 1.25V$ .

Table 1. Jumper JU1 Functions

SHUNT LOCATION	SHDN PIN	MAX1819 OUTPUT
1 and 2	Connected to VIN	MAX1819 enabled, $V_{OUT} = 1.8V$
2 and 3	Connected to GND	Shutdown mode, $V_{OUT} = 0V$
None	Connected to an external source through SHDN pad	MAX1819 output depends on external SHDN signal levels

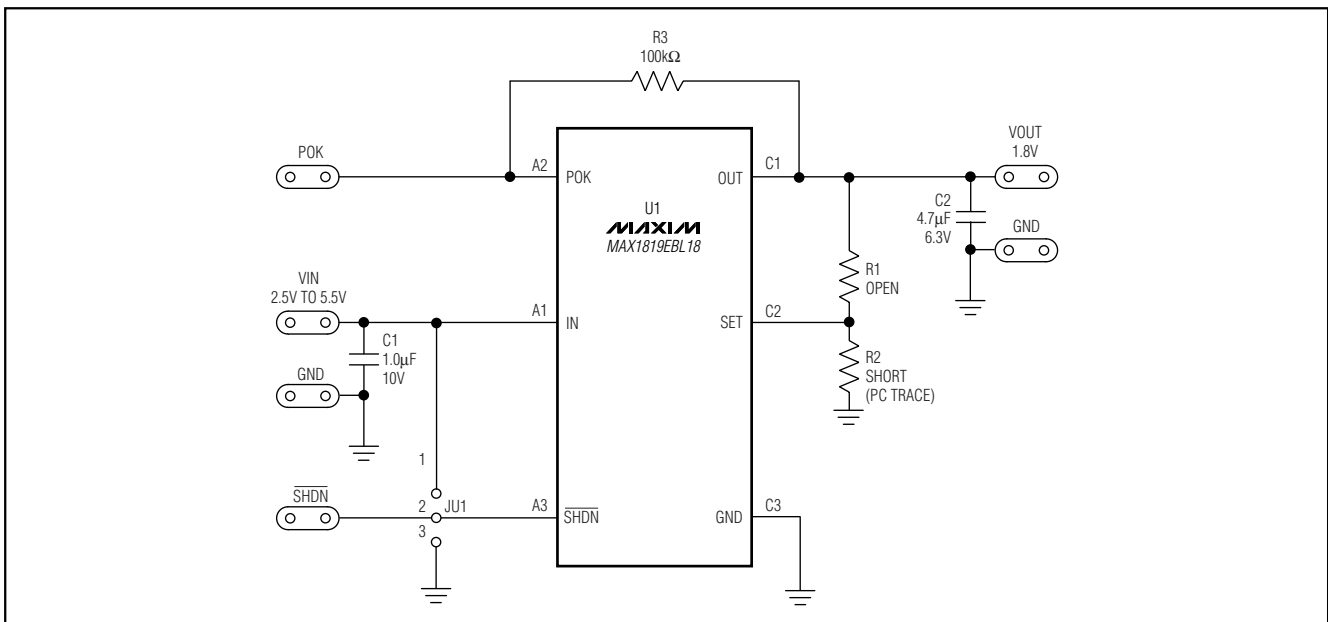

Figure 1. MAX1819 EV Kit Schematic

# MAX1819 Evaluation Kit

Evaluates: MAX1819EBL18

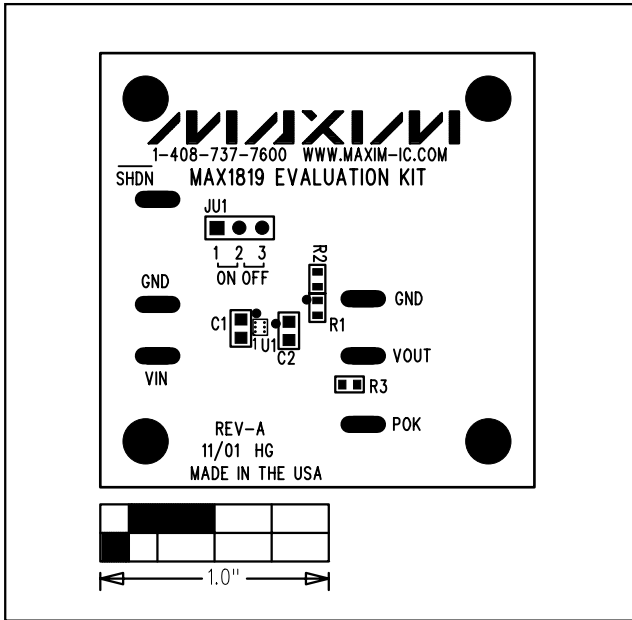

Figure 2. MAX1819 EV Kit Component Placement Guide—Component Side

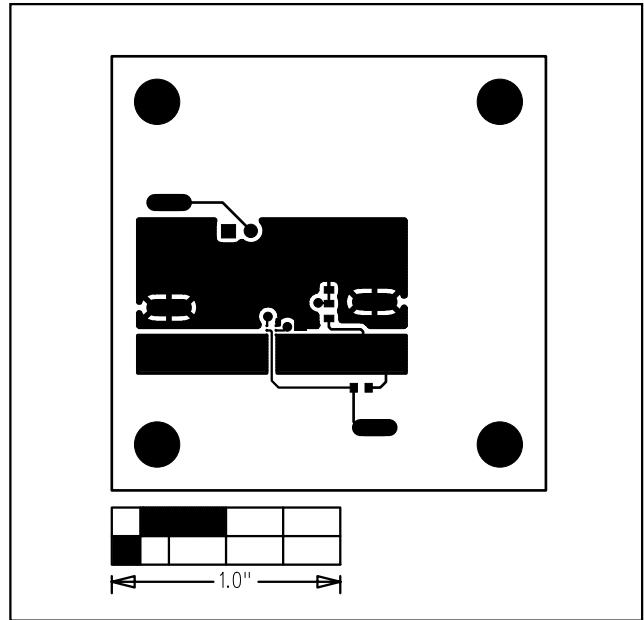

Figure 3. MAX1819 EV Kit PC Board Layout—Component Side

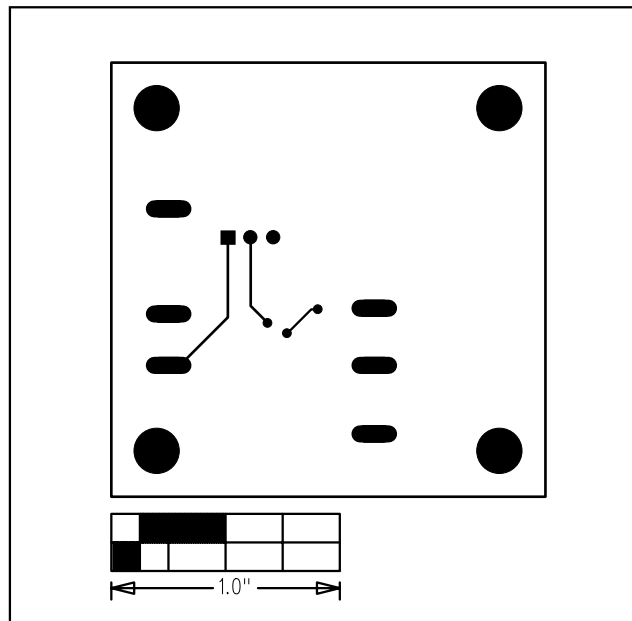

Figure 4. MAX1819 EV Kit PC Board Layout—Solder Side

Maxim cannot assume responsibility for use of any circuitry other than circuitry entirely embodied in a Maxim product. No circuit patent licenses are implied. Maxim reserves the right to change the circuitry and specifications without notice at any time.

Maxim Integrated Products, 120 San Gabriel Drive, Sunnyvale, CA 94086 408-737-7600 \_\_\_\_\_ 3