

MAXIM

MAX1818 Evaluation Kit

General Description

The MAX1818 linear regulator evaluation kit (EV kit) provides a regulated +1.8V output voltage from a +2.5V to +5.5V input source. It delivers up to 500mA output current.

The EV kit is a fully assembled and tested surface-mount PC board. It can also evaluate other preset voltages and other output voltages in the +1.25V to +5.0V range by using external resistors.

Component List

DESIGNATION	QTY	DESCRIPTION
C1	1	1 μ F \pm 10%, 10V X7R ceramic capacitor (0805) Taiyo Yuden LMK212BJ105KG
C2	1	4.7 μ F \pm 20%, 6.3V X5R ceramic capacitor (0805) Taiyo Yuden JMK212BJ475MG or TDK C2012X5R0J475M
R1	0	Not installed (0603)
R2	0	Not installed, pads shorted with PC trace (0603)
R3	1	100k Ω \pm 5% resistor (0603)
U1	1	MAX1818EUT18 (6-pin SOT23)
JU1	1	3-pin header
None	1	Shunt
None	1	MAX1818 PC board
None	1	MAX1818 EV kit data sheet
None	1	MAX1818 data sheet

Component Suppliers

SUPPLIER	PHONE	FAX
Taiyo Yuden	408-573-4150	408-573-4159
TDK	847-390-4373	847-390-4428

Note: Please indicate that you are using the MAX1818 when contacting these component suppliers.

Features

- ◆ +2.5V to +5.5V Input Voltage Range
- ◆ Up to 500mA Output Current
- ◆ Output Voltage
 - +1.8V Fixed Output Voltage (MAX1818EUT18)
 - +1.25 to +5.0V Adjustable Output Voltage (External Divider)
- ◆ Power-OK Output
- ◆ 6-Pin SOT23 Package
- ◆ Surface-Mount Construction
- ◆ Fully Assembled and Tested

Ordering Information

PART	TEMP. RANGE	IC-PACKAGE
MAX1818EVKIT	0°C to +70°C	6 SOT23

Note: To evaluate the MAX1818EUT15, /20, /25, /33, or /50, request a MAX1818EUT15, /20, /25, /33, or /50 free sample with the MAX1818 EV kit. Refer to soldering information in Absolute Maximum Rating section of MAX1818 data sheet for mass production solder reflow advice.

Quick Start

The MAX1818 EV Kit is fully assembled and tested. Follow these steps to verify board operation.

Do not turn on the power supply until all connections are completed.

- 1) Verify that the shunt is across pins 1 and 2 of jumper JU1 (SHDN) (Table 1).
- 2) Connect a voltmeter to the VOUT pad. Connect the ground to the GND pad closest to VOUT.
- 3) Connect a +2.5V to +5.5V supply to the VIN pad. Connect the supply ground to the GND pad closest to VIN.
- 4) Turn on the power supply, and verify that the output is the preset voltage: +1.8V.

To evaluate other voltages, refer to *Evaluating Other Output Voltages*.

Evaluates: MAX1818EUT15/18/20/25/33/50



MAX1818 Evaluation Kit

Detailed Description

The MAX1818 EV kit contains a low-dropout, linear regulator circuit, which provides a +1.8V output from a +2.5V to +5.5V input voltage. The EV kit provides up to 500mA output current. Power-OK will provide a logical low output when the output voltage falls below 93% of its nominal voltage.

The MAX1818 EV kit features a shutdown mode that reduces quiescent current to 0.1µA (typ) to preserve the battery life.

Evaluating Other Output Voltages

The output voltage of the MAX1818 EV kit is preset to +1.8V. To generate an output voltage other than the preset output voltage, cut open the PC trace shorting R2, and install feedback resistors R1 and R2. Select R2 in the 25kΩ to 100kΩ range.

$$V_{OUT} = V_{SET} (1 + R1 / R2)$$

$$R1 = R2 [(V_{OUT} / V_{SET}) - 1]$$

where $V_{SET} = 1.25V$.

The MAX1818 EV kit can also be used to evaluate the MAX1818EUT15, /20, /25, /33, or /50. Replace MAX1818EUT18 with a MAX1818EUT15, /20, /25, /33, or /50. Hand soldering for single unit evaluation on the EV kit is acceptable. Table 2 lists the corresponding output voltage.

Table 1. Jumper JU1 Functions

SHUNT LOCATION	\overline{SHDN} PIN	MAX1818 OUTPUT
1 and 2	Connected to VIN	MAX1818 enabled, $V_{OUT} = +1.8V$
2 and 3	Connected to GND	Shutdown mode, $V_{OUT} = 0V$
None	Connected external source to \overline{SHDN} pad	MAX1818 output depends on external \overline{SHDN} signal

Table 2. MAX1818 EV Kit Corresponding Output Voltage

MAX1818 PART AND SUFFIX	MAX1818 EV KIT FIXED OUTPUT VOLTAGE
MAX1818EUT15	+1.5V
MAX1818EUT18	+1.8V
MAX1818EUT20	+2.0V
MAX1818EUT25	+2.5V
MAX1818EUT33	+3.3V
MAX1818EUT50	+5.0V

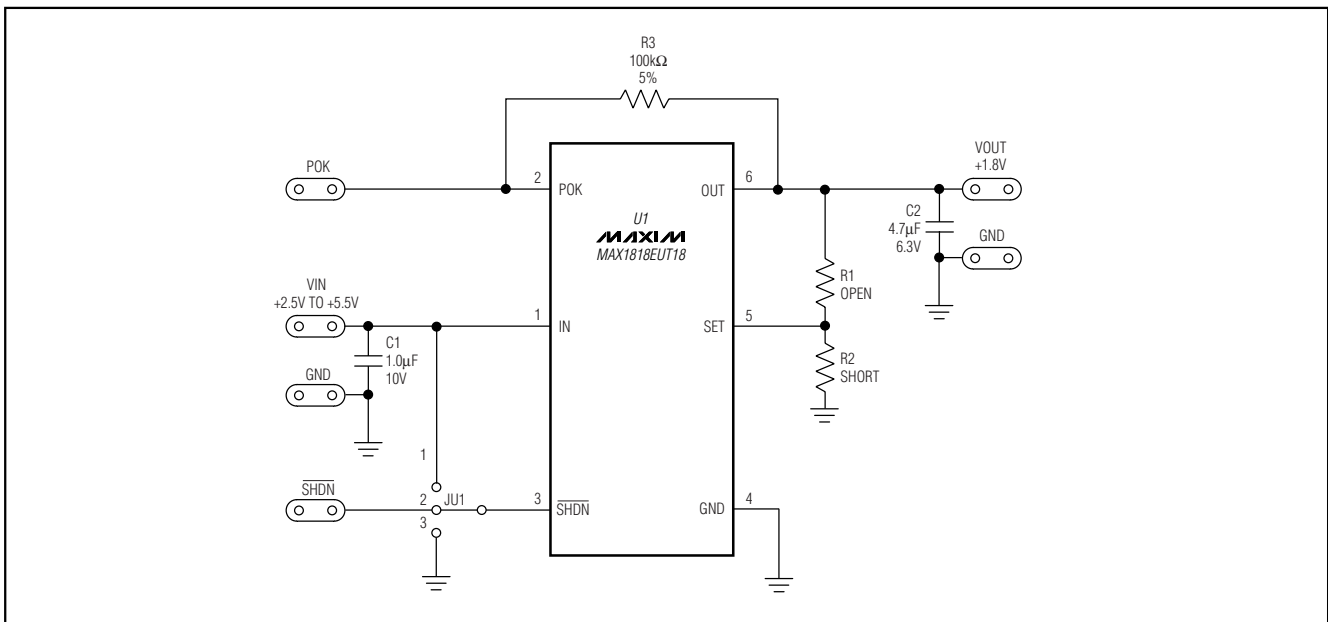

Figure 1. MAX1818 EV Kit Schematic

MAX1818 Evaluation Kit

Evaluates: MAX1818EUT15/18/20/25/33/50

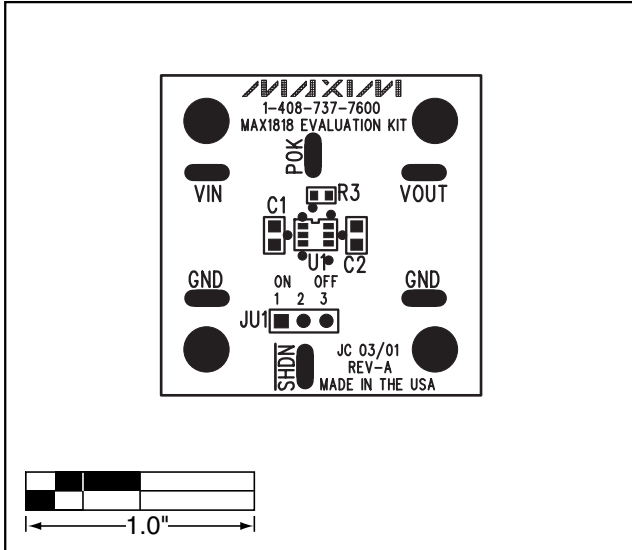

Figure 2. MAX1818 EV Kit Component Placement Guide—Component Side

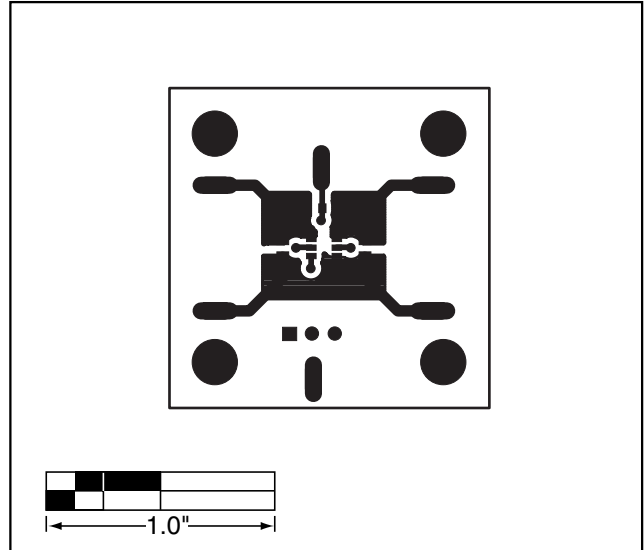

Figure 3. MAX1818 EV Kit PC Board Layout—Component Side

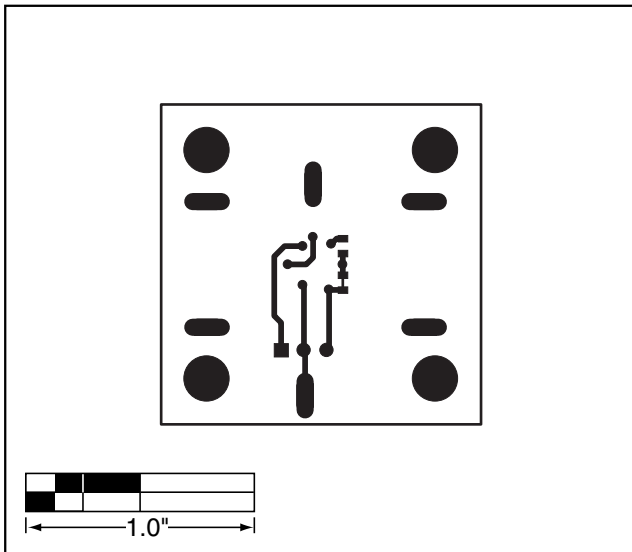

Figure 4. MAX1818 EV Kit PC Board Layout—Solder Side

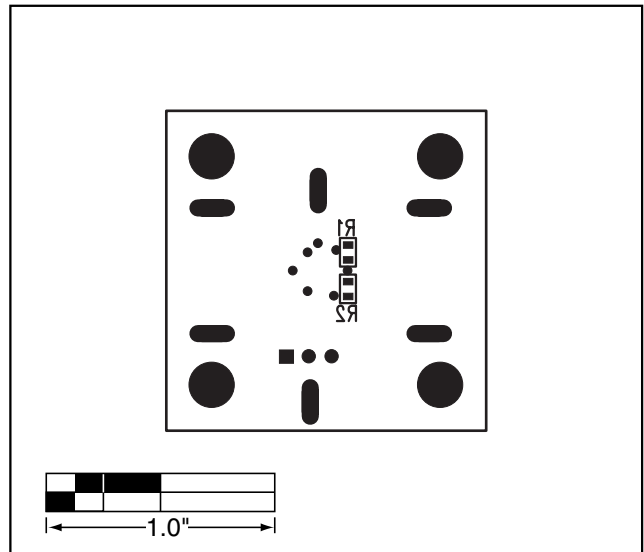

Figure 5. MAX1818 EV Kit Component Placement Guide—Solder Side

Maxim cannot assume responsibility for use of any circuitry other than circuitry entirely embodied in a Maxim product. No circuit patent licenses are implied. Maxim reserves the right to change the circuitry and specifications without notice at any time.

3 Maxim Integrated Products, 120 San Gabriel Drive, Sunnyvale, CA 94086 408-737-7600