



TDA7500A

DIGITAL AM/FM SIGNAL PROCESSOR

- FULL SOFTWARE FLEXIBILITY WITH TWO 24X24 BIT DSP CORES
- SOFTWARE AM/FM, AUDIO AND SOUND-PROCESSING
- HARDWARE RDS FILTER, DEMODULATOR & DECODER
- INTEGRATED CODEC (4ADCs, 6DACs)
- IIC AND SPI CONTROL INTERFACES
- SPI DEDICATED TO DISPLAY MICRO
- 6 CHANNEL SERIAL AUDIO INTERFACE (SAI)
- SPDIF RECEIVER WITH SAMPLE RATE CONVERTER
- EXTERNAL MEMORY INTERFACE (EMI)
- DOUBLE DEBUG INTERFACE
- ON-CHIP PLL
- 5V-TOLERANT 3V I/O INTERFACE
- 12x2 MULTIFUNCTION GENERAL PURPOSE I/O PORTS



DESCRIPTION

The TDA7500A is an integrated circuit implementing a fully digital, integrated and advanced solution to perform the signal processing in front of the power amplifier and behind the AM/FM tuner or any other audio source. The chip integrates two 45 MIPs DSP cores: one for stereo decoding, noise blanking, weak signal processing and multipath detection and one for sound processing, Dolby B, echo and noise cancelling for the telephone.

BLOCK DIAGRAM

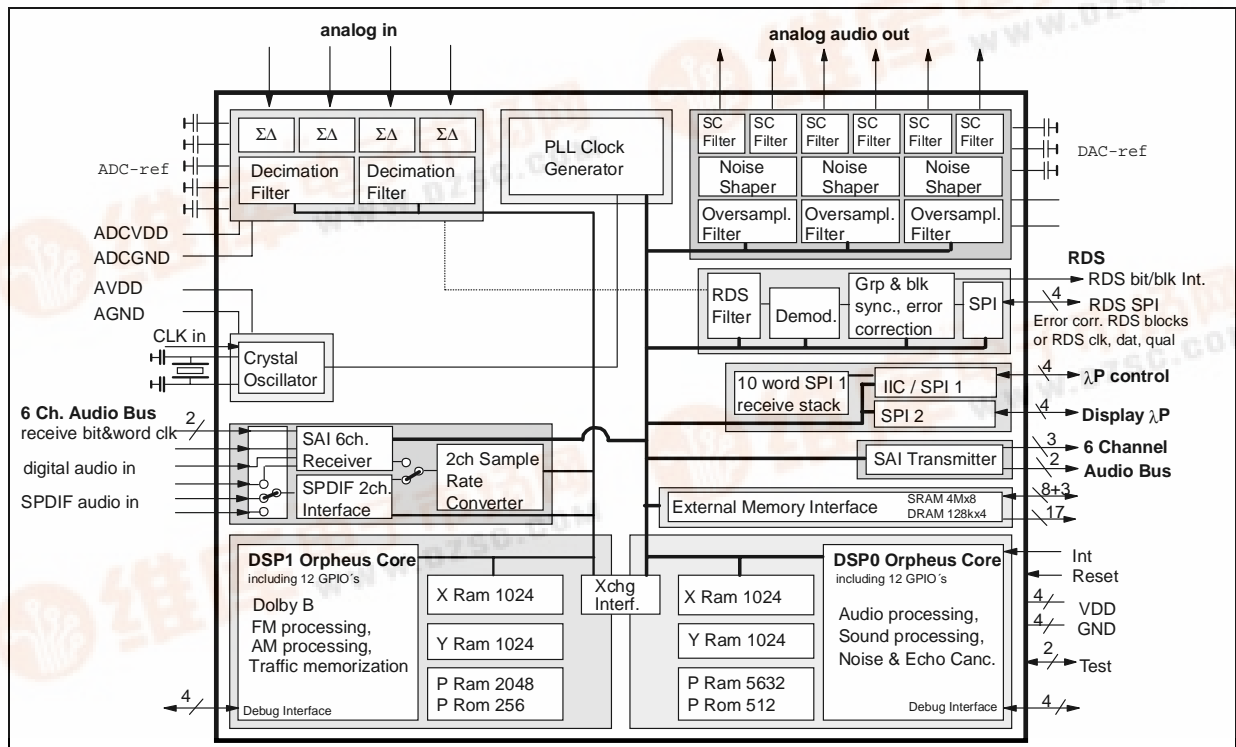

TDA7500A

DESCRIPTION (continued)

An I²C/SPI interface is implemented for control and communication with the main micro. A separate SPI is available to interface the display micro. The DSP cores are integrated with their associated data and program memories. The peripherals and interfaces I²C, SPI, Serial Audio Interface (SAI), PLL Oscillator, External Memory Interface, (EMI), General Purpose I/O register (Port A) and the D/A registers are connected to and controlled by DSP0, whereas the A/D registers, the SPDIF and the General Purpose I/O register (Port B) are connected to and controlled by DSP1. An hardware RDS filter, demodulator and decoder block is also embedded. No support is needed from the DSPs but at initialisation so that RDS can work in background and in parallel with other DSP processing. Separated Debug and Test Interfaces are connected to both DSP cores.

The TDA7500A is supposed to be used in kit with the TDA7501 or any other device of the same family. Thanks to the serial audio interface also digital sources can be processed and a direct output to a digital bus is also available.

The flexibility allowed by the wide memory space and by the two powerful DSP cores make the TDA7500A usable for different applications. In example, inside the main radio as an audio co-processor or to perform the signal processing and equalisation associated to a digital power amplifier.

ABSOLUTE MAXIMUM RATINGS

Symbol	Parameter	Value	Unit
V _{DD} V _{CC}	Power supplies	Digital Analog	V V
V _{aio}	Analog Input and Output Voltage	-0.5 to (V _{CC} +0.5)	V
V _{dio}	Digital Input and Output Voltage	-0.5 to (V _{DD} +0.5)	V
V _{d15}	Digital Input Voltage (5V tolerant)	-0.5 to 6.5	V
T _j	Operating Junction Temperature Range	-40 to 125	°C
T _{stg}	Storage Temperature	-55 to 150	°C

Warning: Operation at or beyond these limit may result in permanent damage to the device. Normal operation is not guaranteed at these extremes.

THERMAL DATA

Symbol	Parameter	Value	Unit
R _{th j-amb}	Thermal resistance junction to ambient ⁽¹⁾	45	°C/W
	Thermal resistance junction to ambient ⁽²⁾	20	°C/W
R _{th j-case}	Thermal junction to case ⁽³⁾	5	°C/W

Note: 1. In still air
2. On 4 layers board with soldered slug
3. Measured on top side of the package

PIN DESCRIPTION

N°	Name	Type	Description
1	GND1		Ground pin dedicated to the digital circuitry.
2	VDD1		Supply pin dedicated to the digital circuitry.
3	TESTEN	I	Test Enable (Input). When low, puts the chip into test mode and muxes the XTI clock to all flip-flops. When TEST_SE is also active, the scan chain shifting is enabled. To be connected to Vdd in operating mode.
4	TESTSE	I	SCAN Enable (Input). When high with TESTEN also active, controls the shifting of the internal scan chains. When active with TESTEN not active, sets all tri-state outputs into hi-impedance mode. To be connected to GND in operating mode.
5	NRESET	I	System Reset (Input). A low level applied to NRESET input initializes the IC.
6	SCKM/DSP0_GPIO0	I/O	I ² C Serial Clock Line (Input/Output)/SPI Bit Clock (Input)/General Purpose I/O (Input/Output). Clock line for I ² C bus. If SPI interface is enabled, behaves as SPI bit clock. Optionally it can be used as general purpose I/O controlled by DSP0.
7	MISOM/DSP0_GPIO1	I/O	I ² C Serial Data Line (Input/Output)/SPI Master Input Slave Output Serial Data (Input/Output)/General Purpose I/O (Input/Output). Data line for I ² C bus. If SPI is enabled, behaves as Serial Data Input when in SPI Master Mode and Serial Data Output when in SPI Slave Mode. Optionally it can be used as general purpose I/O controlled by DSP0.
8	MOSIM/DSP0_GPIO2	I/O	SPI Master Output Slave Input Serial Data (Input/Output)/General Purpose I/O (Input/Output). Serial Data Output when in SPI Master Mode and Serial Data Input when in SPI Slave Mode. Optionally it can be used as general purpose I/O controlled by DSP0.
9	SSM/DSP0_GPIO3	I	SPI Slave Select (Input)/General Purpose I/O (Input/Output). If SPI is enabled, behaves as Slave Select line for SPI bus. Optionally it can be used as general purpose I/O controlled by DSP0.
10	SCKD/DSP0_GPIO4	I	SPI Bit Clock (Input)/General Purpose I/O (Input/Output). SPI bit clock. Optionally it can be used as general purpose I/O controlled by DSP0.
11	MISOD/DSP0_GPIO5	I/O	SPI Master Input Slave Output Serial Data (Input/Output)/General Purpose I/O (Input/Output). Behaves as Serial Data Input when in SPI Master Mode and Serial Data Output when in SPI Slave Mode. Optionally it can be used as general purpose I/O controlled by DSP0.
12	MISOD/DSP0_GPIO6	I/O	SPI Master Output Slave Input Serial Data (Input/Output)/General Purpose I/O (Input/Output). Serial Data Output when in SPI Master Mode and Serial Data Input when in SPI Slave Mode. Optionally it can be used as general purpose I/O controlled by DSP0.
13	SSD/DSP0_GPIO7	I	SPI Slave Select (Input)/General Purpose I/O (Input/Output). Behaves as Slave Select line for SPI bus. Optionally it can be used as general purpose I/O controlled by DSP0.

TDA7500A

PIN DESCRIPTION (continued)

N°	Name	Type	Description
14	CLKIN	I	Clock Input pin (Input). Clock from external digital audio source to synchronize the internal PLL.
15	AVDD		Supply pin dedicated to the PLL.
16	XTI	I	Crystal Oscillator Input (Input). External Clock Input or crystal Oscillator input.
17	XTO	O	Crystal Oscillator Output (Output). Crystal Oscillator output drive.
18	AGND		Ground pin dedicated to the PLL.
19	RDSINT/DSP1_GPIO4	O	RDS bit/block interrupt (Output)/General Purpose I/O (Input/Output). Provides an interrupt to the main micro. Optionally it can be used as general purpose I/O controlled by DSP1.
20	RDSARI_SCK/DSP1_GPIO3	O	SPI Bit Clock (Input)/ARI indicator (Output)/General Purpose I/O (Input/Output). If SPI interface is enabled, behaves as SPI bit clock. Optionally it provides the ARI indication bit. Optionally it can be used as general purpose I/O controlled by DSP1.
21	RDSQAL_SO/DSP1_GPIO2	O	SPI Slave Output Serial Data (Output)/RDS Bit Quality (Output)/General Purpose I/O (Input/Output). If SPI is enabled, behaves as Serial Data Output. Optionally it provides the RDS serial data quality information. Optionally it can be used as general purpose I/O controlled by DSP1.
22	RDSDAT_SI/DSP1_GPIO1	I	SPI Slave Input Serial Data (Input)/RDS Bit Data (Output)/General Purpose I/O (Input/Output). If SPI is enabled, behaves as Serial Data Input. Optionally it provides the RDS serial data stream. Optionally it can be used as general purpose I/O controlled by DSP1.
23	RDSCLK_SS/DSP1_GPIO0	I	SPI Chip Select (Input)/RDS Bit Clock (Output)/General Purpose I/O (Input/Output). If SPI is enabled, behaves as Chip Select line for SPI bus. Optionally it provides the 1187.5Hz RDS Bit Clock. Optionally it can be used as general purpose I/O controlled by DSP1.
24	INT	I	External interrupt line (Input). When this line is asserted low, the DSP may be interrupted. Acts as IRQA line of DSP0 core.
25	CGND1		Ground pin dedicated to the digital circuitry.
26	CVDD1		Supply pin dedicated to the digital circuitry.
27	SCRCCD	I	SPDIF Input 1 (Input). Stereo SPDIF input to connect a digital audio source like a CD.
28	SCRMD	I	SPDIF Input 2 (Input). Stereo SPDIF input to connect a digital audio source like a MD.
29	DSRA<7>	I/O	DSP SRAM Data Lines<7> (Input/Output). When in SRAM Mode this pin act as the EMI data line 7.
30	DSRA<6>	I/O	DSP SRAM Data Lines<6> (Input/Output). When in SRAM Mode this pin act as the EMI data line 6.

PIN DESCRIPTION (continued)

N°	Name	Type	Description
31	DSRA<5>	I/O	DSP SRAM Data Lines<5> (Input/Output). When in SRAM Mode this pin act as the EMI data line 5.
32	DSRA<4>	I/O	DSP SRAM Data Lines<4> (Input/Output). When in SRAM Mode this pin act as the EMI data line 4.
33	DSRA<3>	I/O	DSP SRAM Data Lines<3> (Input/Output)/DSP DRAM Data Line<3>(Input/Output). This pin act as the EMI data line 3 in both SRAM Mode and DRAM Mode.
34	DSRA<2>	I/O	DSP SRAM Data Lines<2> (Input/Output)/DSP DRAM Data Line<2>(Input/Output). This pin act as the EMI data line 2 in both SRAM Mode and DRAM Mode.
35	DSRA<1>	I/O	DSP SRAM Data Lines<1> (Input/Output)/DSP DRAM Data Line<1>(Input/Output). This pin act as the EMI data line 1 in both SRAM Mode and DRAM Mode.
36	DSRA<0>	I/O	DSP SRAM Data Lines<0> (Input/Output)/DSP DRAM Data Line<0>(Input/Output). This pin act as the EMI data line 0 in both SRAM Mode and DRAM Mode.
37	SRA<0>	O	DSP SRAM Address Line<0> (Output)/DSP DRAM Address Line<0> (Output). This pin acts as the EMI address line 0 in both SRAM Mode and DRAM Mode
38	SRA<1>	O	DSP SRAM Address Line<1> (Output)/DSP DRAM Address Line<1> (Output). This pin acts as the EMI address line 1 in both SRAM Mode and DRAM Mode
39	SRA<2>	O	DSP SRAM Address Line<2> (Output)/DSP DRAM Address Line<2> (Output). This pin acts as the EMI address line 2 in both SRAM Mode and DRAM Mode
40	SRA<3>	O	DSP SRAM Address Line<3> (Output)/DSP DRAM Address Line<3> (Output). This pin acts as the EMI address line 3 in both SRAM Mode and DRAM Mode
41	SRA<4>	O	DSP SRAM Address Line<4> (Output)/DSP DRAM Address Line<4> (Output). This pin acts as the EMI address line 4 in both SRAM Mode and DRAM Mode
42	SRA<5>	O	DSP SRAM Address Line<5> (Output)/DSP DRAM Address Line<5> (Output). This pin acts as the EMI address line 5 in both SRAM Mode and DRAM Mode
43	SRA<6>	O	DSP SRAM Address Line<6> (Output)/DSP DRAM Address Line<6> (Output). This pin acts as the EMI address line 6 in both SRAM Mode and DRAM Mode
44	SRA<7>	O	DSP SRAM Address Line<7> (Output)/DSP DRAM Address Line<7> (Output). This pin acts as the EMI address line 7 in both SRAM Mode and DRAM Mode
45	SRA<8>	O	DSP SRAM Address Line<8> (Output)/DSP DRAM Address Line<8> (Output). This pin acts as the EMI address line 8 in both SRAM Mode and DRAM Mode

TDA7500A

PIN DESCRIPTION (continued)

N°	Name	Type	Description
46	SRA<9>	O	DSP SRAM Address Line<9> (Output)/DSP DRAM Address Line<9> (Output). This pin acts as the EMI address line 9 in both SRAM Mode and DRAM Mode
47	SRA<10>	O	DSP SRAM Address Line<10> (Output)/DSP DRAM Address Line<10> (Output). This pin acts as the EMI address line 10 in both SRAM Mode and DRAM Mode
48	SRA<11>	O	DSP SRAM Address Line<11> (Output)/DSP DRAM Address Line<11> (Output). This pin acts as the EMI address line 11 in both SRAM Mode and DRAM Mode
49	SRA<12>	O	DSP SRAM Address Line<12> (Output)/DSP DRAM Address Line<12> (Output). This pin acts as the EMI address line 12 in both SRAM Mode and DRAM Mode
50	CGND2		Ground pin dedicated to the digital circuitry.
51	CVDD2		Supply pin dedicated to the digital circuitry.
52	SRA<13>	O	DSP SRAM Address Line<13> (Output)/DSP DRAM Address Line<13> (Output). This pin act as the EMI address line 13 in both SRAM Mode and DRAM Mode.
53	SRA<14>	O	DSP SRAM Address Line<14> (Output)/DSP DRAM Address Line<14> (Output). This pin act as the EMI address line 14 in both SRAM Mode and DRAM Mode.
54	SRA<15>	O	DSP SRAM Address Line<15> (Output)/DSP DRAM Address Line<15> (Output). This pin act as the EMI address line 15 in both SRAM Mode and DRAM Mode.
55	SRA<16>/DSP0_GPIO8	O	DSP SRAM Address Line<16> (Output)/DSP DRAM Address Line<16> (Output)/General Purpose I/O (Input/Output). This pin acts as the EMI address line 16 in both SRAM Mode and DRAM Mode. Optionally it can be used as general purpose I/O controlled by DSP0. After reset the state of this pin is read by the boot SW to select the boot mode (Refer to HW/SW manual).
56	DWR	O	DSP SRAM Write Enable (Output)/DRAM Write Enable (Output). This pin serves as the write enable for the EMI in both DRAM and SRAM Mode (active low). To be connected to R/W of the RAM.
57	DRD	O	DSP SRAM Read Enable(Output)/DRAM Read Enable (Output). This pin serves as the read enable for the EMI in both DRAM and SRAM Mode (active low). To be connected to R/W of the RAM.
58	CASALE	O	DSP DRAM Column Address Strobe (Output). When in DRAM Mode this pin acts as the column address strobe.
59	SDO<2>/SRA<17>/DSP1_GPIO<8>	O	SAI Outputs (Output)/EMI SRAM Address Line<17> (Output)/General Purpose I/O (Input/Output). One stereo channel SAI data output in SAI mode. EMI address line 17 in SRAM Mode. Optionally it can be used as a general purpose I/O.

PIN DESCRIPTION (continued)

N°	Name	Type	Description
60	SDO<2>/SRA<18>/DSP1_GPIO<7>	O	SAI Outputs (Output)/EMI SRAM Address Line<18> (Output)/ General Purpose I/O (Input/Output). One stereo channel SAI data output in SAI mode. EMI address line 18 in SRAM Mode. Optionally it can be used as a general purpose I/O.
61	SDO<0>/SRA<19>	O	SAI Output (Output)/EMI SRAM Address Line<19> (Output). One stereo channel SAI data output in SAI mode. EMI address line 19 in SRAM Mode.
62	SDI<2>/SRA<20>/DSP1_GPIO<6>	I	SAI Input (Input)/EMI SRAM Address Line<20> (Output)/ General Purpose I/O (Input/Output). One stereo channel SAI data input in SAI mode. EMI address line 20 in SRAM Mode. Optionally it can be used as a general purpose I/O.
63	SDI<1>/SRA<21>/RAS/DSP1_GPIO<5>	I	SAI Input (Input)/EMI SRAM Address Line<21> (Output)/DRAM Row Address Strobe (Output)/General Purpose I/O (Input/Output). One stereo channel SAI data input in SAI mode. EMI address line 21 in SRAM Mode. When in DRAM Mode this pin acts as the row address strobe. Optionally it can be used as a general purpose I/O.
64	SDI<0>/SRCCDC	I	SAI Input (Input)/SPDIF Input 3 (Input). One stereo channel SAI data input in SAI mode. Stereo SPDIF input intended to connect a digital audio source like a CD changer in SPDIF mode.
65	SCKT	I/O	SAI transmitter Bit Clock (Input/Output). SAI transmitter bit clock. Master or slave.
66	LRCKT	I/O	SAI transmitter Left-Right Clock (Input/Output). SAI transmitter Left-Right clock. Can be master or slave mode.
67	SCKR	I	SAI receiver Bit Clock (Input). SAI receiver bit clock. Slave only.
68	LRCKR	I	SAI receiver Left-Right Clock (Input/Output). SAI receiver Left-Right clock. Slave only.
69	DBOUT1/DSP1_GPIO10	I/O	Debug Port Serial Output (Input/Output)/ General Purpose I/O (Input/Output). The serial data output for the Debug Port. Optionally it can be used as a general purpose I/O.
70	DBIN1/OS10/DSP1_GPIO11	I/O	Debug Port Serial Input/Chip Status 0 (Input/Output)/ General Purpose I/O (Input/Output). The serial data input for the Debug Port is provided when an input. When an output, together with OS1 provides information about the chip status. Optionally it can be used as a general purpose I/O.
71	DBCK1/OS11/DSP1_GPIO9	I/O	Debug Port Bit Clock/Chip Status 1 (Input/Output)/General Purpose I/O (Input/Output). The serial clock for the Debug Port is provided when an input. When an output, together with OS0 provides information about the chip status. Optionally it can be used as a general purpose I/O.
72	DBRQN1	I	Debug Port Request Input (Input). Means of entering the Debug mode of operation.
73	DBOUT0/DSP0_GPIO10	I/O	Debug Port Serial Output (Input/Output)/ General Purpose I/O (Input/Output). The serial data output for the Debug Port. Optionally it can be used as a general purpose I/O.

TDA7500A

PIN DESCRIPTION (continued)

N°	Name	Type	Description
74	DBIN0/OS00/DSP0_GPIO11	I/O	Debug Port Serial Input/Chip Status 0 (Input/Output)/ General Purpose I/O (Input/Output). The serial data input for the Debug Port is provided when an input. When an output, together with OS1 provides information about the chip status. Optionally it can be used as a general purpose I/O.
75	DBCK0/OS01/DSP0_GPIO9	I/O	Debug Port Bit Clock/Chip Status 1 (Input/Output)/General Purpose I/O (Input/Output). The serial clock for the Debug Port is provided when an input. When an output, together with OS0 provides information about the chip status. Optionally it can be used as a general purpose I/O.
76	DBRQN0	I	Debug Port Request Input (Input). Means of entering the Debug mode of operation.
77	VDD2		Supply pin dedicated to the digital circuitry.
78	GND2		Ground pin dedicated to the digital circuitry.
79	ADC<0>	I	Analog Inputs (Input). Single ended analog signal inputs to the ADC.
80	ADC<1>	I	Analog Inputs (Input). Single ended analog signal inputs to the ADC.
81	ADC<2>	I	Analog Inputs (Input). Single ended analog signal inputs to the ADC.
82	ADC<3>	I	Analog Inputs (Input). Single ended analog signal inputs to the ADC.
83	S2DREF	I	To be connected to ADCGND
84	ADCVDDREF	I	Voltage Reference (Input). Analog voltage reference input. Signal is supplied by A354. (typical 3.3V).
85	ADCREFL<2>	I	Voltage Reference (Input). External decoupling of the analog references used for the sigma delta modulator.
86	ADCREFL<1>	I	Voltage Reference (Input). External decoupling of the analog references used for the sigma delta modulator.
87	ADCREFL<0>	I	Voltage Reference (Input). External decoupling of the analog references used for the sigma delta modulator.
88	ADCVDD		Analog Supply pin dedicated to the A/D converter.
89	ADCGND		Analog Ground pin dedicated to the A/D converter.
90	DAC<0>	O	Analog Outputs (Output). Analog signal outputs of the DAC
91	DAC<1>	O	Analog Outputs (Output). Analog signal outputs of the DAC
92	DAC<2>	O	Analog Outputs (Output). Analog signal outputs of the DAC
93	DAC<3>	O	Analog Outputs (Output). Analog signal outputs of the DAC
94	DAC<4>	O	Analog Outputs (Output). Analog signal outputs of the DAC
95	DAC<5>	O	Analog Outputs (Output). Analog signal outputs of the DAC

PIN DESCRIPTION (continued)

N°	Name	Type	Description
96	DACREF<2>	I	Voltage Reference (Input). External decoupling of the analog references of the CODEC and voltage biasing.
97	DACREF<1>	I	Voltage Reference (Input). It can be connected to pin 100.
98	DACREF<0>	I	Voltage Reference (Input). External decoupling of the analog references of the CODEC and voltage biasing.
99	DACGND		Analog Ground pin dedicated to the D/A converter.
100	DACVDD		Analog Supply pin dedicated to the D/A converter.

I/O DEFINITION AND STATUS

O: logic low output

X: undefined input/output

Z: high impedance

1: logic input output

Pin #	Function	Reset State	After Boot			I/O	Comments
			SPI	I ² C	EMI		
1	GND1					supply	
2	VDD1					supply	To be connected to VDD
3	TESTEN	X	X	X	X	input	To be connected to GND
4	TESTSE	X	X	X	X	input	Ext. Pulldown
5	NRESET	X	X	X	X	input 5VT	
6	MSPI: SCKM input MSPI: SCKM output I2C: SCL bi-direct DSP0: GPIO0 input DSP0: GPIO0 output	X	X	(1)	(1)	input 5VT output 4mA PP input 5VT/output 4mA OD input 5VT output 4mA OD	(1) undefined input
7	MSPI: MISOM input MSPI: MISOM output I2C: SDA bi-direct DSP0: GPIO1 input DSP0: GPIO1 output	X	0 or 1	X	X	input 5VT output 4mA OD input 5VT/output 4mA OD input 5VT output 4mA PP	
8	MSPI: MOSIM input MSPI: MOSIM output DSP0: GPIO2 input DSP0: GPIO2 output	X	X	X	X	input 5VT output 4mA OD input 5VT output 4mA OD	
9	MSPI: SSM input DSP0: GPIO3 input DSP0: GPIO3 output	X	X	X	X	input 5VT input 5VT output 4mA PP	
10	DSPI: SCKD input DSPI: SCKD output DSP0: GPIO4 input DSP0: GPIO4 output	X	X	X	X	input 5VT output 4mA PP input 5VT output 4mA PP	

TDA7500A

I/O DEFINITION AND STATUS (continued)

Pin #	Function	Reset State	After Boot			I/O	Comments
			SPI	I ² C	EMI		
11	DSP1: MISOD input DSP1: MISOD output DSP0: GPIO5 input DSP0: GPIO5 output	X	X	X	X	input 5VT output 4mA OD input 5VT output 4mA OD	
12	DSP1: MOSID input DSP1: MOSID output DSP0: GPIO6 input DSP0: GPIO6 output	X	X	X	X	input 5VT output 4mA OD input 5VT output 4mA OD	
13	DSP1: SSD input DSP0 : GPIO7 input DSP0 : GPIO7 output		X	X	X	input 5VT input 5VT output 4mA PP	
14	PLL: CLKIN input	X	X	X	X	input	
15	PLL: AVDD					supply	
16	PLL: XTI input	X	X	X	X	analog input	max. 20 MHz
17	PLL: XTO output	X	X	X	X	analog output	
18	PLL: AGND					supply	
19	RDS: RDSINT output DSP1: GPIO4 input DSP1: GPIO4 output	X	X	X	X	output 4mA PP onput 5VT output 4mA PP	
20	RDS: RDSARI output RDS SPI: SCK input DSP1: GPIO3 input DSP1: GPIO3 output	X	X	X	X	output 4mA PP input 5VT input 5VT output 4mA PP	
21	RDS: RDSQAL output RDS SPI: SO input DSP1: GPIO2 input DSP1: GPIO2 output	X	X	X	X	output 4mA OD output 4mA OD input 5VT output 4mA OD	
22	RDS: RDSDAT output RDS SPI: SI input DSP1: GPIO1 input DSP1: GPIO1 output	X	X	X	X	output 4mA PP input 5VT input 5VT output 4mA PP	
23	RDS: RDSCLK output RDS SPI: SS input DSP1: GPIO0 input DSP1: GPIO0 output	X	X	X	X	output 4mA PP input 5VT input 5VT output 4mA PP	
24	INT input	X	X	X	X	input 5VT	Ext. Pullup
25	CGND1					supply	
26	CVDD1					supply	
27	SCRCCD input	X	X	X	X	input 5VT	
28	SCRCCMD input	X	X	X	X	input 5VT	
29	EMI SRAM: Data<7> bi-direct	1	1	1	Z	input/output 2mA PP	

I/O DEFINITION AND STATUS (continued)

Pin #	Function	Reset State	After Boot			I/O	Comments
			SPI	I ² C	EMI		
30	EMI SRAM: Data<6> bi-direct	1	1	1	Z	input/output 2mA PP	
31	EMI SRAM: Data<5> bi-direct	1	1	1	Z	input/output 2mA PP	
32	EMI SRAM: Data<4> bi-direct	1	1	1	Z	input/output 2mA PP	
33	EMI SRAM: Data<3> bi-direct EMI SRAM: Data<3> bi-direct	1	1	1	Z	input/output 2mA PP	
34	EMI SRAM: Data<2> bi-direct EMI SRAM: Data<2> bi-direct	1	1	1	Z	input/output 2mA PP	
35	EMI SRAM: Data<1> bi-direct EMI SRAM: Data<1> bi-direct	1	1	1	Z	input/output 2mA PP	
36	EMI SRAM: Data<0> bi-direct EMI SRAM: Data<0> bi-direct	1	1	1	Z	input/output 2mA PP	
37	EMI SRAM: Add<0> output EMI SRAM: Add<0> output	1	1	1	0/1	output 2mA PP output 2mA PP	
38	EMI SRAM: Add<1> output EMI SRAM: Add<1> output	1	1	1	0/1	output 2mA PP output 2mA PP	
39	EMI SRAM: Add<2> output EMI SRAM: Add<2> output	1	1	1	0/1	output 2mA PP output 2mA PP	
40	EMI SRAM: Add<3> output EMI SRAM: Add<3> output	1	1	1	0/1	output 2mA PP output 2mA PP	
41	EMI SRAM: Add<4> output EMI SRAM: Add<4> output	1	1	1	0/1	output 2mA PP output 2mA PP	
42	EMI SRAM: Add<5> output EMI SRAM: Add<5> output	1	1	1	0/1	output 2mA PP output 2mA PP	
43	EMI SRAM: Add<6> output EMI SRAM: Add<6> output	1	1	1	0/1	output 2mA PP output 2mA PP	
44	EMI SRAM: Add<7> output EMI SRAM: Add<7> output	1	1	1	0/1	output 2mA PP output 2mA PP	
45	EMI SRAM: Add<8> output EMI SRAM: Add<8> output	1	1	1	0/1	output 2mA PP output 2mA PP	
46	EMI SRAM: Add<9> output EMI SRAM: Add<9> output	1	1	1	0/1	output 2mA PP output 2mA PP	
47	EMI SRAM: Add<10> output EMI SRAM: Add<10> output	1	1	1	0/1	output 2mA PP output 2mA PP	
48	EMI SRAM: Add<11> output EMI SRAM: Add<11> output	1	1	1	0/1	output 2mA PP output 2mA PP	
49	EMI SRAM: Add<12> output EMI SRAM: Add<12> output	1	1	1	0/1	output 2mA PP output 2mA PP	
50	CGND2					supply	
51	CVDD2					supply	

TDA7500A

I/O DEFINITION AND STATUS (continued)

Pin #	Function	Reset State	After Boot			I/O	Comments
			SPI	I ² C	EMI		
52	EMI SRAM: Add<13> output EMI SRAM: Add<13> output	1	1	1	0/1	output 2mA PP output 2mA PP	
53	EMI SRAM: Add<14> output EMI SRAM: Add<14> output	1	1	1	0/1	output 2mA PP output 2mA PP	
54	EMI SRAM: Add<15> output EMI SRAM: Add<15> output	1	1	1	0/1	output 2mA PP output 2mA PP	
55	EMI SRAM: Add<16> output EMI SRAM: Add<16> output DSP0: GPIO8 input DSP0: GPIO8 output	X	X	X	X	output 2mA PP output 2mA PP input output 2mA PP	
56	EMI SRAM: WR output EMI DRAM: WR output	1	1	1	1	output 2mA PP output 2mA PP	
57	EMI SRAM: RD output EMI DRAM: RD output	1	1	1	1	output 2mA PP output 2mA PP	
58	EMI SRAM: ALE output EMI DRAM: CAS output	1	1	1	0	output 2mA PP output 2mA PP	
59	SAI: SDO2 output EMI SRAM: Add<17> output DSP1: GPIO8 input DSP1: GPIO8 output	X	X	X	X	output 2mA PP output 2mA PP input output 2mA PP	
60	SAI: SDO1 output EMI SRAM: Add<18> output DSP1: GPIO7 input DSP1: GPIO7 output	X	X	X	X	output 2mA PP output 2mA PP input output 2mA PP	
61	SAI: SDO0 output EMI SRAM: Add<19> output	1	1	1	1	output 2mA PP output 2mA PP	
62	SAI: SDI2 input EMI SRAM: Add<20> output DSP1: GPIO6 input DSP1: GPIO6 output	X	X	X	X	input output 2mA PP input output 2mA PP	
63	SAI: SDI2 input EMI SRAM: Add<21> output EMI DRAM: RAS output DSP1: GPIO5 input DSP1: GPIO5 output	X	X	X	X	input output 2mA PP output 2mA PP input output 2mA PP	
64	SAI: SDI0 input SPDIF: CD input	X	X	X	X	input input	
65	SAI: SCKT input SAI: SCKT output	X	X	X	X	input output 2mA PP	
66	SAI: LRCKT input SAI: LRCKT output	X	X	X	X	input output 2mA PP	
67	SAI: SCKR input	X	X	X	X	input	
68	SAI: LRCKR input	X	X	X	X	input	

I/O DEFINITION AND STATUS (continued)

Pin #	Function	Reset State	After Boot			I/O	Comments
			SPI	I ² C	EMI		
69	DSP1 Debug: DBOUT output DSP1: GPIO10 input DSP1: GPIO10 output	X	1	1	1	output 4mA PP input 5VT output 4mA PP	After boot in debug mode
70	DSP1 Debug: DBIN input DSP1 : OS10 output DSP1: GPIO11 input DSP1: GPIO11 output	X	X	X	X	input 5VT output 4mA PP input 5VT output 4mA PP	After boot in debug mode
71	DSP1 Debug: DBCK input DSP1 : OS11 output DSP1: GPIO9 input DSP1: GPIO9 output	X	X	X	X	input 5VT output 4mA PP input 5VT output 4mA PP	After boot in debug mode
72	DSP1 Debug: DBRQN input	X	X	X	X	input 5VT	After boot in debug mode
73	DSP0 Debug: DBOUT output DSP0: GPIO10 input DSP0: GPIO10 output	X	1	1	1	output 4mA PP input 5VT output 4mA PP	After boot in debug mode
74	DSP0 Debug: DBIN input DSP0 : OS00 output DSP0: GPIO11 input DSP0: GPIO11 output	X	X	X	X	input 5VT output 4mA PP input 5VT output 4mA PP	After boot in debug mode
75	DSP0 Debug: DBCK input DSP0 : OS01 output DSP0: GPIO9 input DSP0: GPIO9 output	X	X	X	X	input 5VT output 4mA PP input 5VT output 4mA PP	After boot in debug mode
76	DSP0 Debug: DBRQN input	X	X	X	X	input 5VT	
77	GND2					supply	
78	VDD2					supply	
79	ADC<0>input	X	X	X	X	analog input	
80	ADC<1>input	X	X	X	X	analog input	
81	ADC<2>input	X	X	X	X	analog input	
82	ADC<3>input	X	X	X	X	analog input	
83	ADC: S2DREF input					Substrate biasing	connected to GND
84	ADC: ADCVDDREF input					voltage reference	connect 47μF electrolytic and 100nF Ceramic parallel to ADCGND
85	ADC: REF<2> input					voltage reference	connect 100μF electrolytic and 100nF Ceramic parallel to ADCGND

TDA7500A

I/O DEFINITION AND STATUS (continued)

Pin #	Function	Reset State	After Boot			I/O	Comments
			SPI	I ² C	EMI		
86	ADC: REF<1> input					voltage reference	connect 47μF electrolytic and 100nF Ceramic parallel to ADCGND
87	ADC: REF<0> input					voltage reference	connect 47μF electrolytic and 100nF Ceramic parallel to ADCGND
88	ADCVDD					ADC power supply	
89	ADCGND					ADC ground	
90	DAC<0> output	X	X	X	X	analog output	
91	DAC<1> output	X	X	X	X	analog output	
92	DAC<2> output	X	X	X	X	analog output	
93	DAC<3> output	X	X	X	X	analog output	
94	DAC<4> output	X	X	X	X	analog output	
95	DAC<5> output	X	X	X	X	analog output	
96	DAC: REF<2> input					voltage reference	connect 47μF electrolytic and 100nF Ceramic parallel to DACGND
97	DAC: REF<1> input					voltage reference	connect 47μF electrolytic and 100nF Ceramic parallel to DACGND (It can be connected to Pin100)
98	DAC: REF<0> input					voltage reference	connect to DACGND (It can be connected to Pin99)
99	DACGND					DAC ground	
100	DACVDD					DAC power supply	

Output **PP**: Push-Pull/ **OD**: Open-Drain

5VT input: TTL Five Volt Tolerant Input - Schmitt-trigger for all inputs.

PIN CONNECTION (Top view)

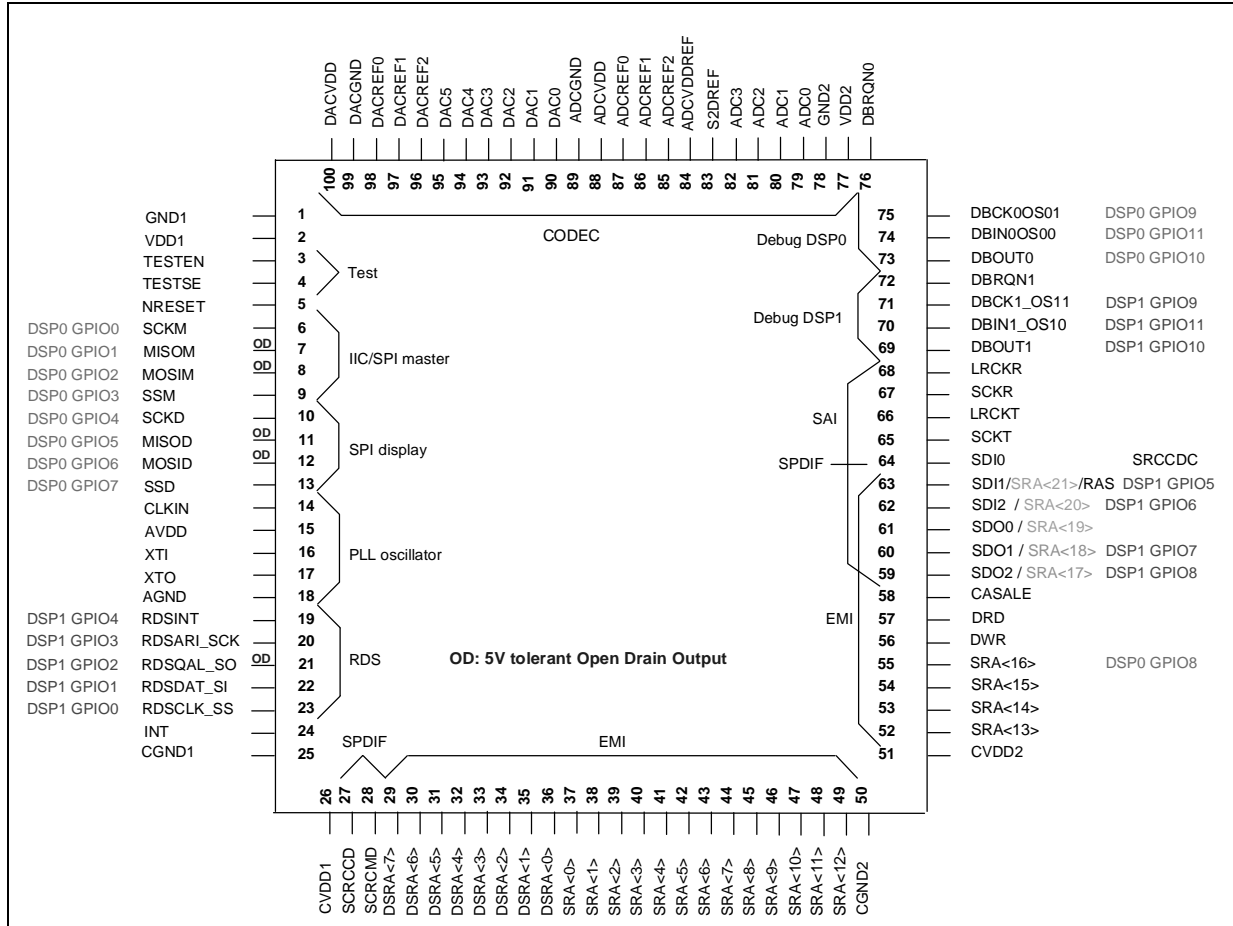

RECOMMENDED DC OPERATING CONDITIONS

Symbol	Parameter	Test Condition	Min.	Typ.	Max.	Unit
V _{DD}	3.3V Digital Power Supply Voltage		3.15	3.3	3.45	V
V _{CC}	3.3V Analog Power Supply Voltage		3.15	3.3	3.45	V

POWER CONSUMPTION

Symbol	Parameter	Test Condition	Min.	Typ.	Max.	Unit
I _{dd}	Total Maximum Current	power supply @ 3.3V and T _j = 125°C		450	490	mA

Note: 45MHz internal DSP clock, 4ADC and 6DAC enabled.

PLL CHARACTERISTICS

Symbol	Parameter	Test Condition	Min.	Typ.	Max.	Unit
	Lock Time (note 1)	power supply @ 3.3V and T _j = 125°C			3	ms
F _{VCO}	VCO Frequency (note 2)		70		140	MHz

Note: 1. Depending on VCO output frequency.

2. F_{dsp} = F_{vco}/2 when PLL is running



TDA7500A

OSCILLATOR CHARACTERISTICS

Symbol	Parameter	Test Condition	Min.	Typ.	Max.	Unit
F _{OSC}	Max Oscillator Frequency (XTI)	power supply @ 3.3V and T _j = 125°C			20	MHz

GENERAL INTERFACE ELECTRICAL CHARACTERISTICS

Symbol	Parameter	Test Condition	Min.	Typ.	Max.	Unit
I _{il}	Low Level Input Current without pullup device	V _i = 0V (note 1)			1	μA
I _{ih}	High Level Input Current without pullup device	V _i = V _{dd} (note 1)			1	μA
I _{oz}	Tri-state Output leakage without pull up/down device	V _o = 0V or V _{dd} (note 1)			1	μA
I _{ozFT}	5V Tolerant Tri-state Output leakage without pull up/down device	V _o = 0V or V _{dd} (note 1)			1	μA
		V _o = 5.5V		1	3	μA
I _{latchup}	I/O latch-up current	V < 0V, V > V _{dd}	200			mA
V _{esd}	Electrostatic Protection	Leakage , 1μA (note 2)	2000			V

Note: 1. The leakage currents are generally very small, <1nA. The value given here, 1mA, is a maximum that can occur after an Electrostatic Stress on the pin.
2. Human Body Model.

LOW VOLTAGE CMOS INTERFACE DC ELECTRICAL CHARACTERISTICS

Symbol	Parameter	Test Condition	Min.	Typ.	Max.	Unit
V _{il}	Low Level Input Voltage				0.2*V _{dd}	V
V _{ih}	High Level Input Voltage		0.8*V _{dd}			V
V _{hyst}	Schmitt trigger hysteresis		0.8			V
V _{ol}	Low level output Voltage	I _{ol} = XmA (notes 1, 2)			0.4	V
V _{oh}	High level output Voltage		0.85*V _{dd}			V

Note: 1. Takes into account 200mV voltage drop in both supply lines.
2. X is the source/sink current under worst case conditions and is reflected in the name of the I/O cell according to the drive capability.

LOW VOLTAGE TTL INTERFACE DC ELECTRICAL CHARACTERISTICS

Symbol	Parameter	Test Condition	Min.	Typ.	Max.	Unit
V _{il}	Low Level Input Voltage	(note 1)			0.8	V
V _{ih}	High Level Input Voltage	(note 1)	2			V
V _{ilhyst}	Low level threshold input falling	(note 1)	0.9		1.35	V
V _{ihhyst}	Low level threshold input falling	(note 1)	1.3		1.9	V
V _{hyst}	Schmitt trigger hysteresis	(note 1)	0.4		0.7	V
V _{ol}	Low level output Voltage	I _{ol} = XmA (notes 1, 2 & 3)			0.4	V
V _{oh}	High level output Voltage		2.4			V

Note: 1. TTL specifications only apply to the supply voltage range V_{dd} = 3.0V to 3.6V
2. Takes into account 200mV voltage drop in both supply lines.
3. X is the source/sink current under worst case conditions and is reflected in the name of the I/O cell according to the drive capability.

DSP CORE

Symbol	Parameter	Test Condition	Min.	Typ.	Max.	Unit
F _{dsp}	Maximum DSP clock frequency	power supply @ 3.3V and T _j = 125°C	48			MHz

FM Stereo Decoder

Symbol	Parameter	Test Condition	Min.	Typ.	Max.	Unit
a_ch	Channel Separation			>50		dB
THD	Total Harmonic Distortion			0.02		%
(S+N)/N	Signal plus Noise to Noise ratio			86		dB

ADC ELECTRICAL CHARACTERISTICS (T_{amb} = 25°C, V_{CC} = 3.3V, measurement bandwidth 10Hz to 20KHz, A-Weighted Filter.)

Symbol	Parameter	Test Condition	Min.	Typ.	Max.	Unit
	Input Voltage Dynamic Range			0.75	0.8	V _{rms}
	Sampling rate	Audio mode			48	KHz
	Attenuation @ 20KHz	@ fs = 44.1KHz		-0.6		dB
	Dynamic Range	-60dB analog input	84	88		dB
	SNR	1KHz; -3dB analog input	84	88		dB
	(THD + N)	-3dB analog input (note 1)		-85	-80	dB
	Input Impedance	@ fs = 44.1KHz	40	55	75	kΩ
	Crosstalk	1V _{rms} input @ 1KHz			-85	dB
	Gain mismatch between four input	@ 1KHz	-0.5		0.5	dB

Note1: 0dB reference at 0.75V_{rms} input**ADC ELECTRICAL CHARACTERISTICS** (T_{amb} = 25°C, V_{CC} = 3.3V, measurement bandwidth 10Hz to 53KHz.)

Symbol	Parameter	Test Condition	Min.	Typ.	Max.	Unit
	Input Voltage Dynamic Range			0.75	0.8	V _{rms}
	Sampling rate	AM-Mode			192	KHz
	Dynamic Range	-60dB analog input	80			dB
	SNR	1KHz; -3dB analog input	80			dB
	(THD +N)	-3dB analog input			-80	dB

TDA7500A

ADC ELECTRICAL CHARACTERISTICS ($T_{amb} = 25^{\circ}\text{C}$, $V_{CC} = 3.3\text{V}$, measurement bandwidth 10Hz to 160KHz.)

Symbol	Parameter	Test Condition	Min.	Typ.	Max.	Unit
	Input Voltage Dynamic Range			0.75	0.8	Vrms
	Sampling rate	FM-Mode			390	KHz
	Dynamic Range	-60dB analog input	60			dB
	SNR	1KHz; -3dB analog input	60			dB

DAC PERFORMANCE ($T_{amb} = 25^{\circ}\text{C}$, $V_{CC} = 3.3\text{V}$, measurement bandwidth 10Hz to 20KHz, A-Weighted Filter 0dB gain, output load 30k Ω)

Symbol	Parameter	Test Condition	Min.	Typ.	Max.	Unit
	Output voltage dynamic range		0.87	0.9	0.93	Vrms
	Sampling rate				48	KHz
	Attenuation @ 20kHz	@ 20KHz with $f_s = 44.1\text{KHz}$	-0.3	-0.2		dB
	Dynamic Range	-60dB analog input	90	93		dB
	SNR	1KHz -3dB analog output	90	93		dB
	Digital Silence	0000hex digital input		93		dB
	(THD + N)/S	@ digital full scale		-85	-83	dB
	Output Impedance			25	50	Ω
	Crosstalk	1Vrms output @ 1KHz		-90	-86	dB
	Gain mismatch between six outputs	@ 1KHz	-0.5		0.5	dB

SAI INTERFACE

Figure 1. SAI Timings

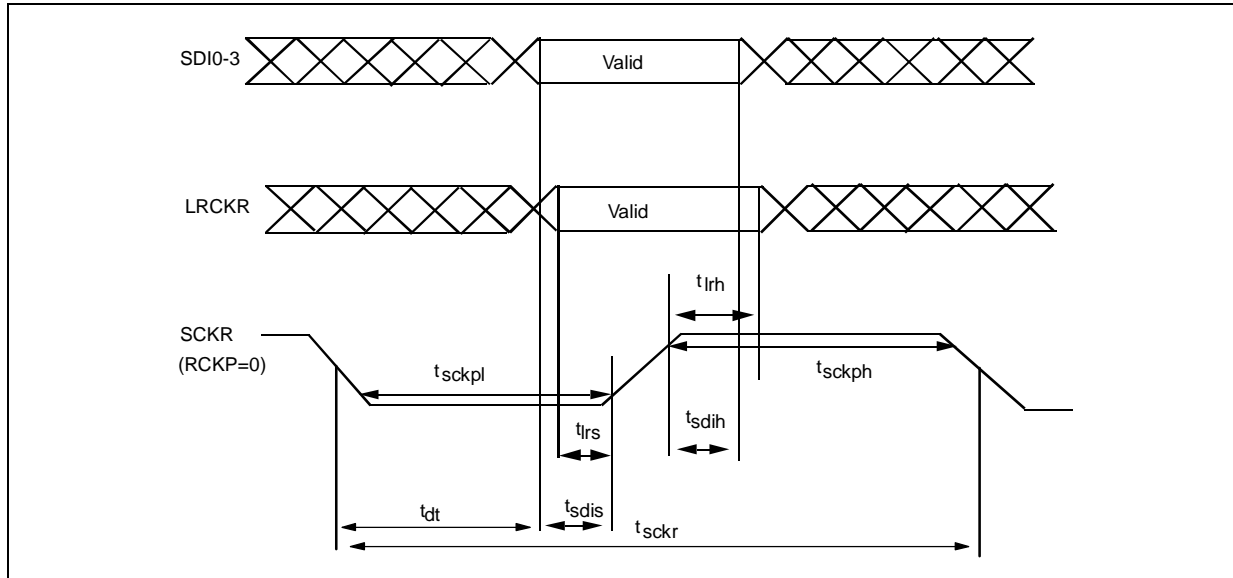

Timing	Description	Value	Unit
t_{sckr}	Minimum Clock Cycle	$4T_{DSP}$	ns
t_{dt}	SCKR active edge to data out valid	10	ns
t_{lrs}	LRCK setup time	5	ns
t_{lrh}	LRCK hold time	5	ns
t_{sdid}	SDI setup time	15	ns
t_{sdih}	SDI hold time	15	ns
t_{sckph}	Minimum SCK high time	$0.35 t_{sckr}$	ns
t_{sckpl}	Minimum SCK low time	$0.35 t_{sckr}$	ns

Note T_{DSP} = dsp master clock cycle time = $1/F_{DSP}$

Figure 2. SAI protocol when RLRS=0; RREL=0; RCKP=1; RDIR=0

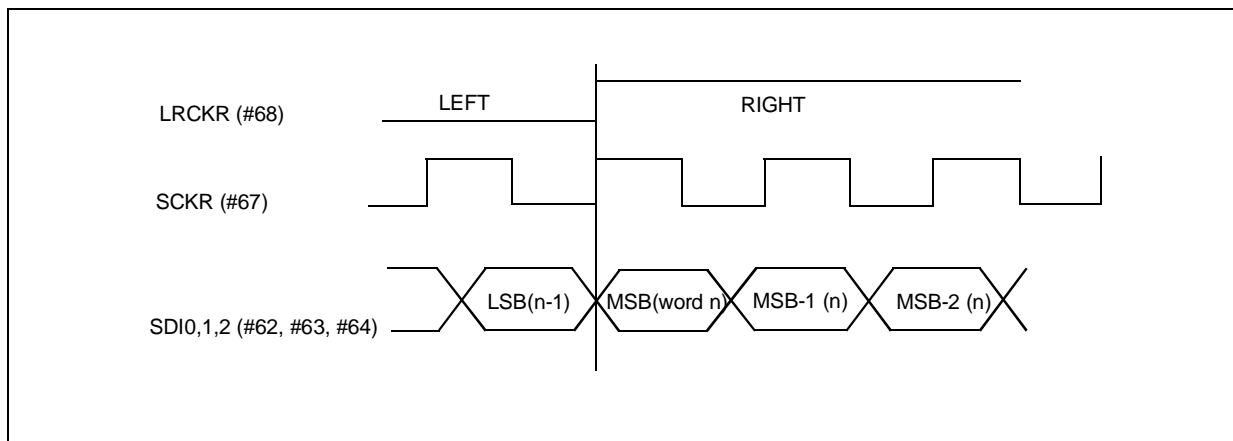

Figure 3. SAI protocol when RLRS=1; RREL=0; RCKP=1; RDIR=1.

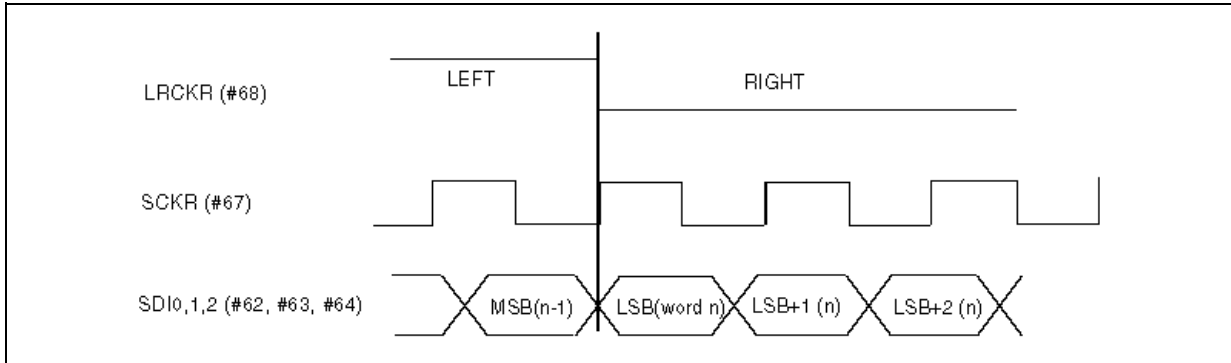

Figure 4. SAI protocol when RLRS=0; RREL=0; RCKP=0; RDIR=0.

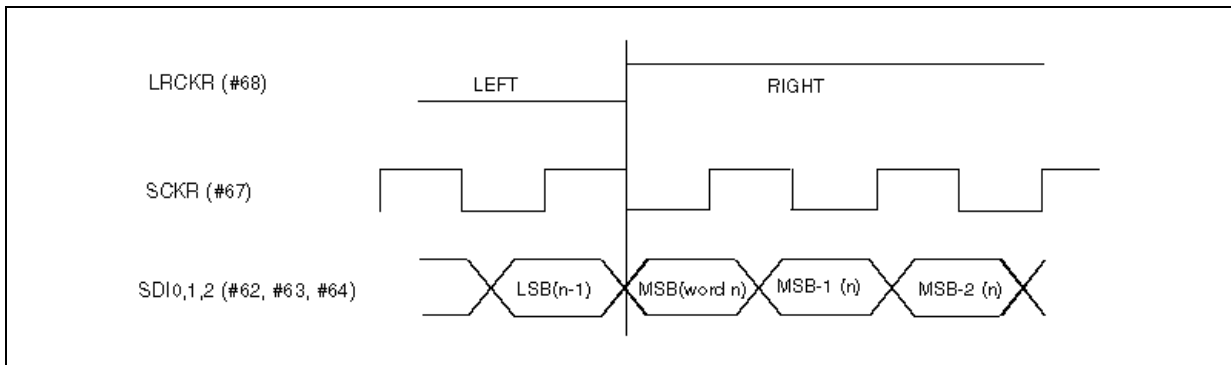
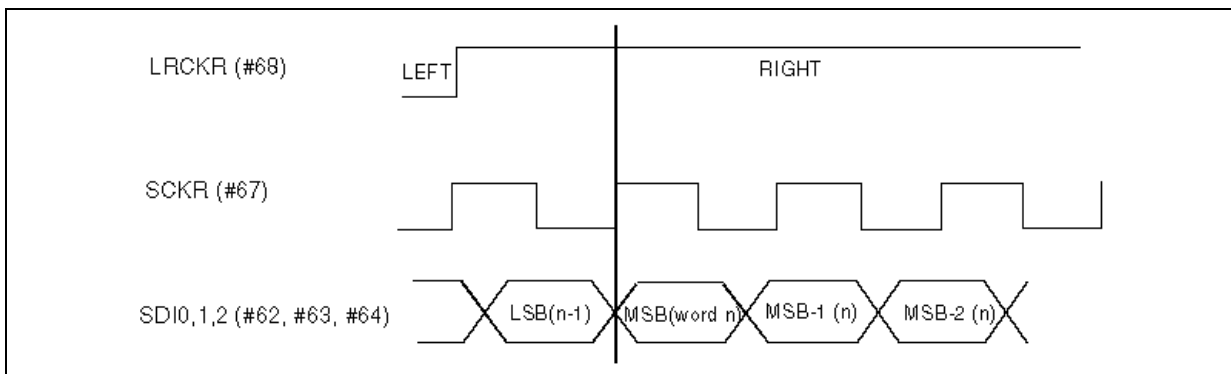

Figure 5. SAI protocol when RLRS=0; RREL=1; RCKP=1; RDIR=0.



SPI INTERFACES

10 WORDS MAIN MICRO SPI

Symbol	Description	Min Value	Unit
MASTER			
t_{sclk}	Clock Cycle	$12T_{DSP}$	ns
t_{dtr}	Sclk edge to MOSI valid	40	ns
$t_{misosetup}$	MISO setup time	16	ns
$t_{misohold}$	MISO hold time	4	ns
t_{sclkh}	SCK high time	$0.5t_{sclk}$	ns
t_{sckl}	SCK high low	$0.5t_{sclk}$	ns
SLAVE			
t_{sclk}	Clock Cycle	$12T_{DSP}$	ns
t_{dtr}	Sclk edge to MOSI valid	40	ns
$t_{mosisetup}$	MOSI setup time	16	ns
$t_{mosihold}$	MOSI hold time	4	ns
t_{sclkh}	SCK high time	$0.5t_{sclk}$	ns
t_{sckl}	SCK high low	$0.5t_{sclk}$	ns

DISPLAY SPI (different timings)

MASTER			
t_{sclk}	Clock Cycle	$6T_{DSP}$	ns
SLAVE			
t_{sclk}	Clock Cycle	$6T_{DSP}$	ns

Figure 6. SPI Clocking scheme.

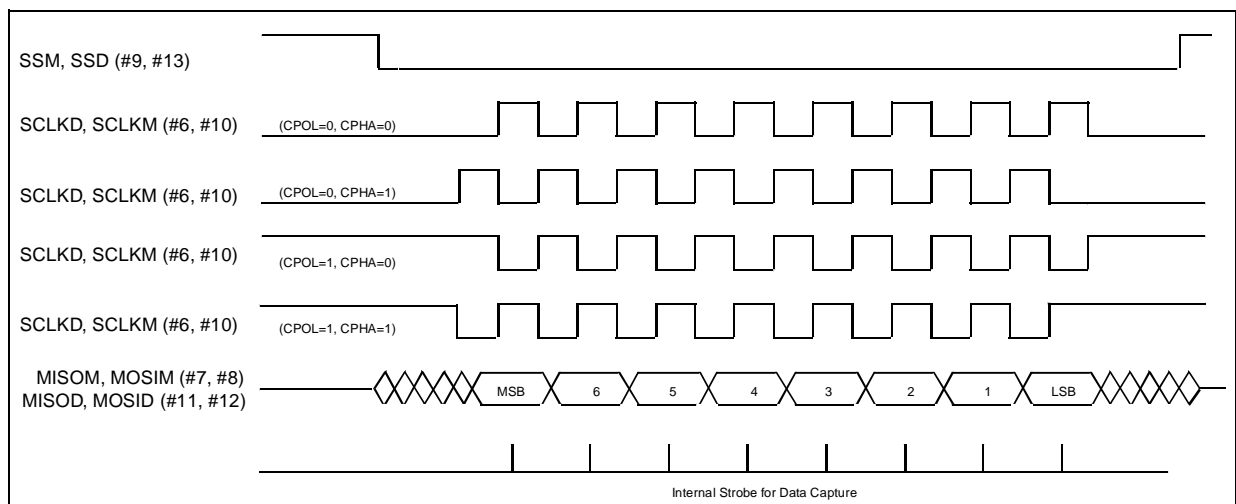

Debug Port Interface

No.	Characteristics	dclk = 40MHz		Unit
		Min.	Max.	
1	DBCK rise time	--	3	ns
2	DBCK fall time	--	3	ns
3	DBCK Low	40	--	ns
4	DBCK High	40	--	ns
5	DBCK Cycle Time	200	--	ns
6	DBRQN Asserted to DBOUT (ACK) Asserted	5 TDSP	--	ns
7	DBCK High to DBOUT Valid	--	42	ns
8	DBCK High to DBOUT Invalid	3	--	ns
9	DBIN Valid to DBCK Low (Set-up)	15	--	ns
10	DBCK Low to DBIN Invalid (Hold)	3	--	ns
	DBOUT (ACK) Asserted to First DBCK High	2 Tc	--	ns
	DBOUT (ACK) Assertion Width	4.5 TDSP - 3	5 TDSP + 7	ns
11	Last DBCK Low of Read Register to First DBCK High of Next Command	7 TDSP + 10	--	ns
12	Last DBCK Low to DBOUT Invalid (Hold)	3	--	ns
	DBSEL setup to DBCK	TDSP		ns

Figure 7. Debug Port Serial Clock Timing.

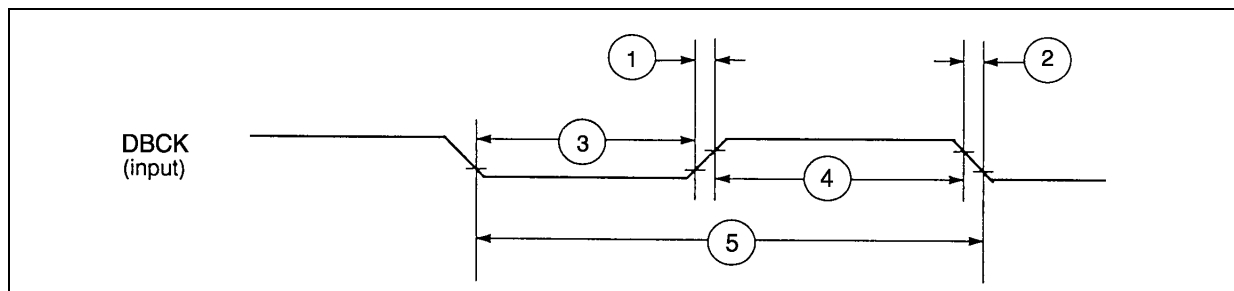

Figure 8. Debug Port Acknowledge Timing.

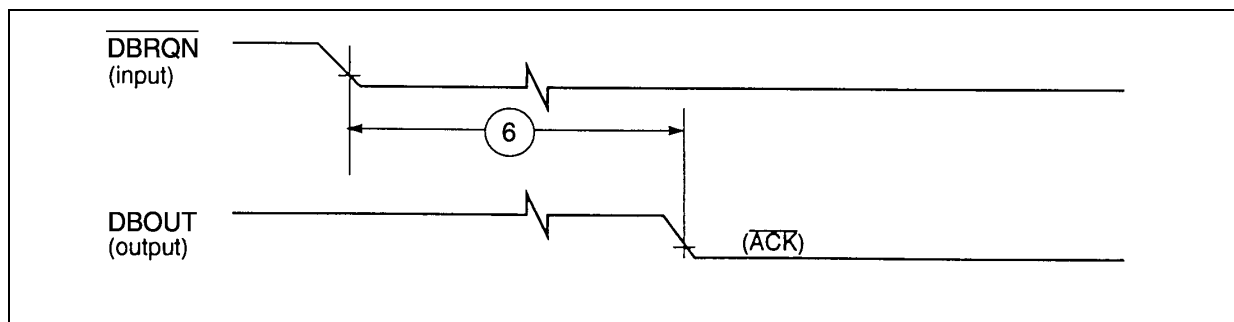

Figure 9. Debug Port Data I/O to Status Timing.

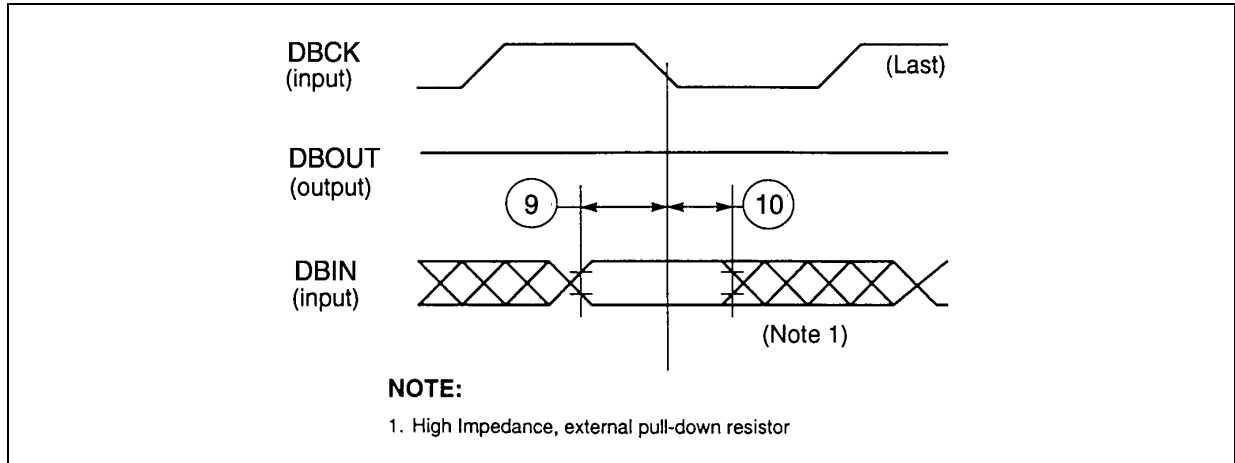

Figure 10. Debug Port Read Timing.

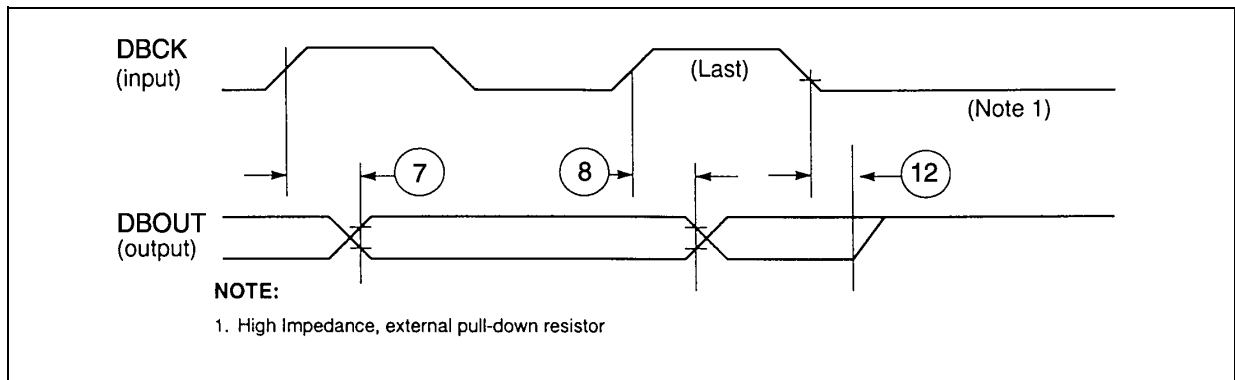
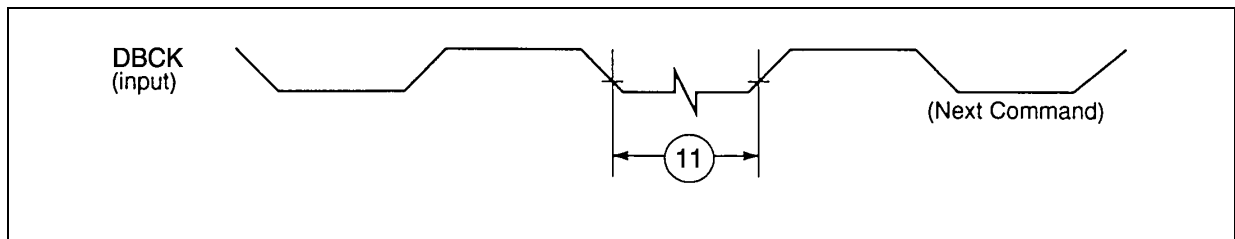

Figure 11. Debug Port DBCK Next Command After Read Register Timing.



TDA7500A

EXTERNAL MEMORY INTERFACE (EMI) DRAM MODE

Characteristics	Timing Mode	40MHz		Unit
		Min.	Max.	
Page Mode Cycle Time	slow	10075	----	ns
	fast			ns
$\overline{\text{RAS}}$ or $\overline{\text{RD}}$ Assertion to Data Valid	slow	--	159	ns
	fast	--	109	ns
CAS Assertion to Data Valid	slow	--	65	ns
	fast	--	40	ns
Column Address Valid to Data Valid	slow	--	80	ns
	fast	--	55	ns
$\overline{\text{CAS}}$ Assertion to Data Active		0	--	ns
RAS Assertion Pulse Width (Note 1) (Page Mode Access Only)	slow	264	--	ns
	fast	189	--	ns
RAS Assertion Pulse Width (Single Access Only)	slow	164	--	ns
	fast	114	--	ns
$\overline{\text{RAS}}$ or $\overline{\text{CAS}}$ Negation to $\overline{\text{RAS}}$ Assertion	slow	120	--	ns
	fast	70	--	ns
CAS Assertion Pulse Width	slow	65	--	ns
	fast	40	--	ns
Last $\overline{\text{CAS}}$ Assertion to $\overline{\text{RAS}}$ Negation (Page Mode Access Only)	slow	60	--	ns
	fast	35	--	ns

Note: 1. n is the number of successive accesses. n = 2, 3, 4, or 6.

DRAM Refresh Timing

Characteristics	Timing Mode	40MHz		Unit
		Min.	Max.	
$\overline{\text{RAS}}$ Negation to $\overline{\text{RAS}}$ Assertion	slow	143	--	ns
	fast	93	--	ns
CAS Negation to $\overline{\text{CAS}}$ Assertion	slow	118	--	ns
	fast	68	--	ns
Refresh Cycle Time	slow	325	--	ns
	fast	225	--	ns
RAS Assertion Pulse Width	slow	166	--	ns
	fast	116	--	ns
RAS Negation to $\overline{\text{RAS}}$ Assertion for Refresh Cycle (Note 1)	slow	120	--	ns
	fast	70	--	ns
$\overline{\text{CAS}}$ Assertion to $\overline{\text{RAS}}$ Assertion on Refresh Cycle		18	--	ns
RAS Assertion to $\overline{\text{CAS}}$ Negation on Refresh Cycle	slow	160	--	ns
	fast	110	--	ns
RAS Negation to $\overline{\text{CAS}}$ Assertion on a Refresh Cycle	slow	114	--	ns
	fast	64	--	ns
$\overline{\text{CAS}}$ Negation to Data Not Valid		0	--	ns

Note: 1. Happens when a Refresh Cycle is followed by an Access Cycle.

EXTERNAL MEMORY INTERFACE (EMI) SRAM MODE

Characteristics	40MHz		Unit
	Min.	Max.	
Address Valid and \overline{CS} Assertion Pulse Width	89	--	ns
Address Valid to \overline{RD} or \overline{WR} Assertion	23	--	ns
\overline{RD} or \overline{WR} Assertion Pulse Width	45	--	ns
\overline{RD} or \overline{WR} Negation to \overline{RD} or \overline{WR} Assertion	39	--	ns
\overline{RD} or \overline{WR} Negation to Address not Valid	5	--	ns
Address Valid to Input Data Valid	--	72	ns
\overline{RD} Assertion to Input Data Valid	--	35	ns
\overline{RD} Negation to Data Not Valid (Data Hold Time)	0	--	ns
Address Valid to \overline{WR} Negation	73	--	ns
Data Setup Time to \overline{WR} Negation	32	--	ns
Data Hold Time from \overline{WR} Negation	5	--	ns
\overline{WR} Assertion to Data Valid	--	18	ns
\overline{WR} Negation to Data High-Z (Note 1)	--	23	ns
\overline{WR} Assertion to Data Active	5	--	ns

Figure 12. External Memory Interface SRAM Read Cycle.

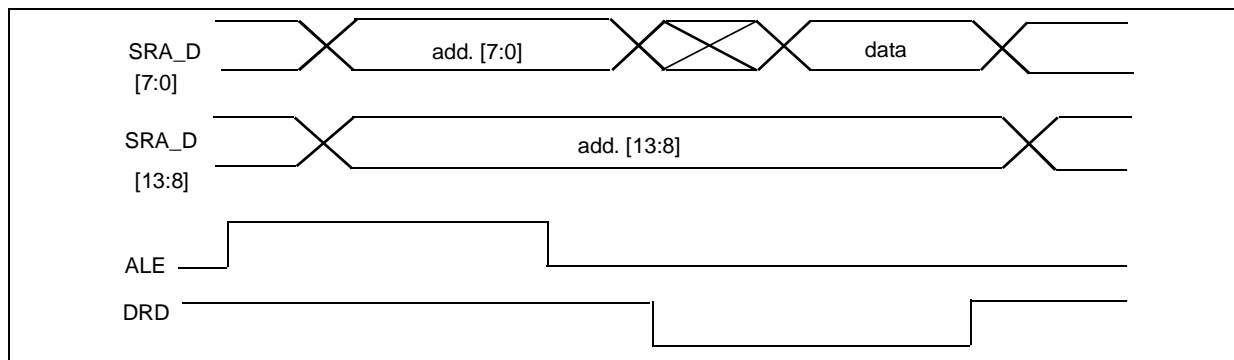

Figure 13. External Memory Interface SRAM Write Cycle.

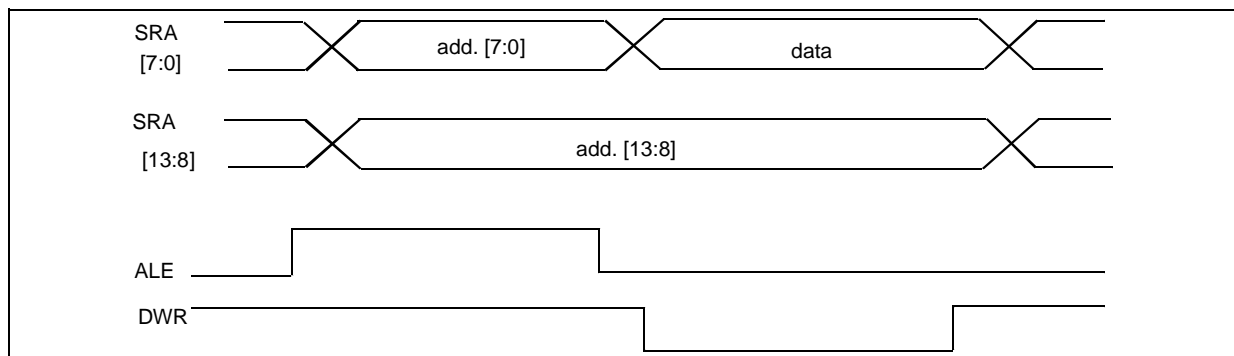

Figure 14. DRAM Read Cycle.

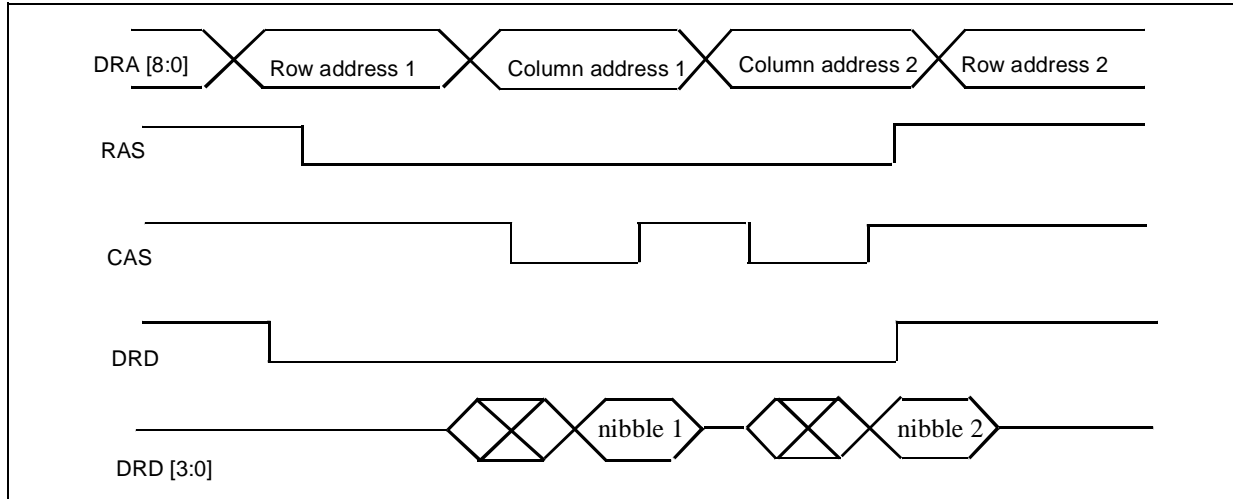
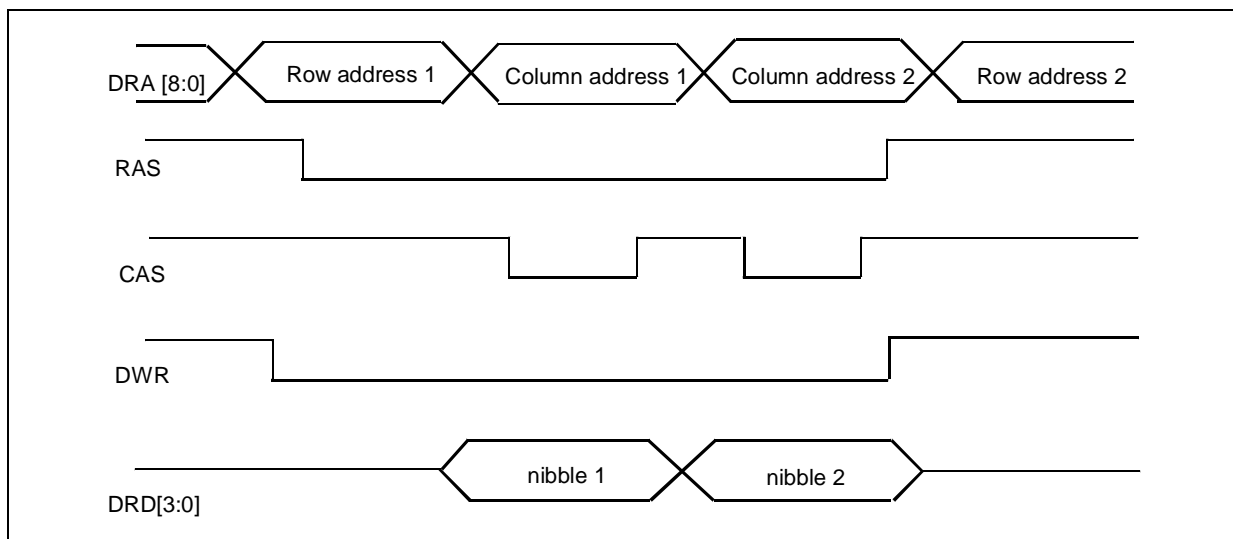

Figure 15. DRAM Write Cycle.



SAMPLE RATE CONVERTER

$$F_{\text{sin}}/F_{\text{sout}} = 1 \text{ (44.1KHz)}$$

Symbol	Parameter	Test Condition	Min.	Typ.	Max.	Unit
THD+N	Total Harmonic Distortion + Noise	20Hz to 20kHz, Full Scale, 16 bit inp.			-98	dB
		20Hz to 20kHz, Full Scale, 20 bit inp.			-101	dB
		1 kHz Full Scale, 16 bit inp.			-98	dB
		10 kHz Full Scale, 16 bit inp.			-98	dB
		1 kHz Full Scale, 20 bit inp.			-109	dB
		10 kHz Full Scale, 20 bit inp			-102	dB
DR	Dynamic Range	1 kHz -60 dB - 16 bit inp.,A-Weighted	98			dB
		1 kHz -60 dB - 20 bit inp.,A-Weighted	120			dB
IPD	Interchannel Phase Deviation				0	Degree
f_c	Cutoff Frequency	@ -3 dB		20		Hz
R_p	Pass Band Ripple	from 0 to 20kHz	-0.05		+0.05	dB
R_s	Stopband Attenuation	@24.1kHz		-105		dB
T_g	Group Delay	$F_{\text{sout}} = 44.1 \text{ kHz}$		612		μs
F_{ratio}	$F_{\text{sin}} / F_{\text{sout}}$		0.7		1.05	

RDS TIMING

Symbol	Parameter	Test Condition	Min.	Typ.	Max.	Unit
F_{crystal}	Crystal Frequency	First mode	-	8.55	-	MHz
		Second mode	-	8.664	-	MHz
t_{bclk}	RDS SPI Bit Clock	(T_{DSP} is the period of the dsp core)	$3T_{\text{DSP}}$	-	-	ns
t_{dis}	SPI Disable time between 2 transfers		$3T_{\text{DSP}}$	-	-	ns

The RDS block adhere to the timings defined by the RDS standard EN50067. More information are also available in the dedicated Applllication Note.

I²C TIMING

Figure 16. Definition of Timing for the I²C BUS.

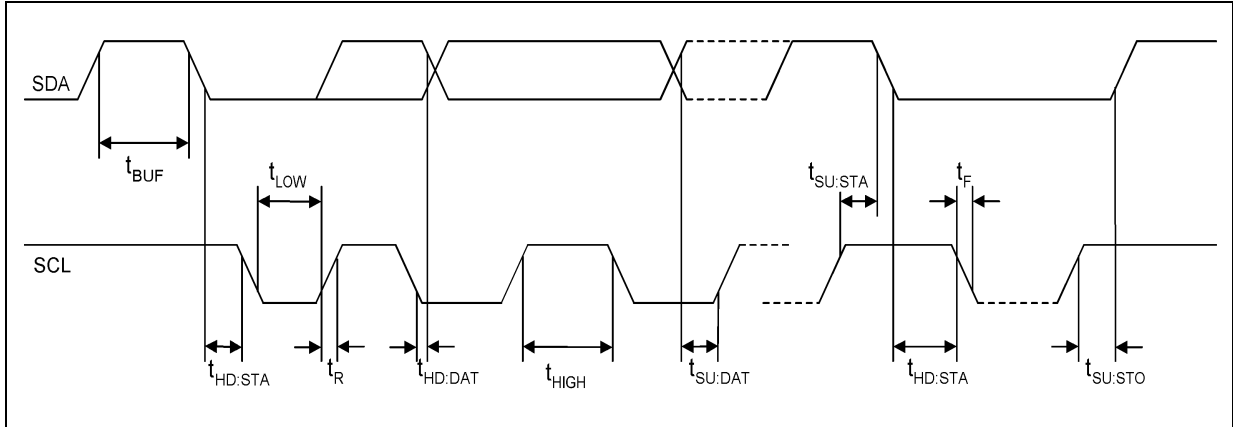

Symbol	Parameter	Test Condition	Standard Mode I ² C BUS		Fast Mode I ² C BUS		Unit
			Min.	Max.	Min.	Max.	
F _{SCL}	SCL clock frequency		0	100	0	400	kHz
t _{BUF}	Bus free between a STOP and Start Condition		4.7	–	1.3	–	μs
t _{HD:STA}	Hold time (repeated) START condition. After this period, the first clock pulse is generated		4.0	–	0.6	–	μs
t _{LOW}	LOW period of the SCL clock		4.7	–	1.3	–	μs
t _{HIGH}	HIGH period of the SCL clock		4.0	–	0.6	–	μs
t _{SU:STA}	Set-up time for a repeated start condition		4.7	–	0.6	–	μs
t _{HD:DAT}	DATA hold time		0	–	0	0.9	μs
t _R	Rise time of both SDA and SCL signals	C _b in pF	–	1000	20+ 0.1C _b	300	ns
t _F	Fall time of both SDA and SCL signals	C _b in pF	–	300	20+ 0.1C _b	300	ns
t _{SU:STO}	Set-up time for STOP condition		4	–	0.6	–	μs
t _{SU:DAT}	Data set-up time		250	--	--	100	ns
C _b	Capacitive load for each bus line		–	400	–	400	pF

SPDIF TIMING

Symbol	Parameter	Test Condition	Min.	Typ.	Max.	Unit
SPVL	AC input level		0.2	0.5	3.3	V _{pp}
SPIR	Input impedance	@ 1 kHz	–	6	–	kΩ
SPHYS	Hysteresis of input		–	40	–	mV

FUNCTIONAL DESCRIPTION

The TDA7500A IC broken up into two distinct blocks. One block contains the two DSP Cores and their associated peripherals. The other contains the ADC, DAC and the RDS filter, demodulator and decoder.

24-BIT DSP CORE

The two DSP cores are used to process the audio and FM/AM data, coming from the ADC, either any kind of digital data coming via SPDIF or SAI. After the digital signal processing these data are sent to the DAC for analog conversion. Functions such as volume, tone, balance, and fader control, as well as spatial enhancement and general purpose signal processing may be performed by the DSP0. When FM/AM mode is selected, DSP1 is fully devoted to AM/FM processing. Nevertheless it can be used for any kind of different application, when a different input source is selected.

Some capabilities of the DSPs are listed below:

- Single cycle multiply and accumulate with convergent rounding and condition code generation
- 2 x 56-bit Accumulators
- Double precision multiply
- Scaling and saturation arithmetic
- 48-bit or 2 x 24-bit parallel moves
- 64 interrupt vector locations
- Fast or long interrupts possible
- Programmable interrupt priorities and masking
- 8 each of Address Registers, Address Offset Registers and Address Modulo Registers
- Linear, Reverse Carry, Multiple Buffer Modulo, Multiple Wrap-around Modulo address arithmetic
- Post-increment or decrement by 1 or by offset, Index by offset, predecrement address
- Repeat instruction and zero overhead DO loops
- Hardware stack capable of nesting combinations of 7 DO loops or 15 interrupts/subroutines
- Bit manipulation instructions possible on all registers and memory locations, also Jump on bit test
- 4 pin serial debug interface
- Debug ccess to all internal registers, buses and memory locations
- 5 word deep program address history FIFO
- Hardware and software breakpoints for both program and data memory accesses
- Debug Single stepping, Instruction injection and Disassembly of program memory

DSP PERIPHERALS

There are a number of peripherals that are tightly coupled to the two DSP Cores. Some of the peripherals are connected to DSP 0 others are connected to DSP1.

- 5.5k x 24-Bit Program RAM for DSP0
- 1k x 24-Bit X-Data RAM for DSP0
- 1k x 24-Bit Y-Data RAM for DSP0
- 2k x 24-Bit Program RAM for DSP1
- 1k x 24-Bit X-Data RAM for DSP1
- 1k x 24-Bit Y-Data RAM for DSP1
- Serial Audio Interface (SAI)
- SPDIF receiver with sampling rate conversion

TDA7500A

- I2C and SPI interface
- XCHG Interface for DSP to DSP communication
- External Memory Interface (DRAM/SRAM) for time-delay and traffic information
- Double Debug Port

DATA AND PROGRAM MEMORY

Both DSP0 and DSP1 have Data and Program memories attached to them. Each of the memories are described below and it is implied that there are two of each type, one set connected to DSP0 and the other to DSP1. The only exception is the case of the P-RAM where DSP1 has a 2048 x 24-Bit PRAM and DSP0 has a 5.5K x 24-Bit PRAM.

1024 x 24-Bit X-RAM (XRAM)

This is a 1024 x 24-Bit Single Port SRAM used for storing coefficients. The 16-Bit XRAM address, XABx(15:0) is generated by the Address Generation Unit of the DSP core. The 24-Bit XRAM Data, XDBx(23:0), may be written to and read from the Data ALU of the DSP core. The XDBx Bus is also connected to the Internal Bus Switch so that it can be routed to and from all peripheral blocks.

1024 x 24 Bit Y-RAM (YRAM)

This is a 512 x 24-Bit Single Port SRAM used for storing coefficients. The 16-Bit address, YABx(15:0) is generated by the Address Generation Unit of the DSP core. The 24-Bit Data, YDBx(23:0), is written to and read from the Data ALU of the DSP core. The YDBx Bus is also connected to the Internal Bus Switch so that it can be routed to and from other blocks.

2048 x 24-Bit Program RAM (PRAM 5.5K x 24-bit for DSP0)

This is a 2048 x 24-Bit Single Port SRAM used for storing and executing program code. The 16-Bit PRAM Address, PABx(15:0) is generated by the Program Address Generator of the DSP core for Instruction Fetching, and by the AGU in the case of the Move Program Memory (MOVEM) Instruction. The 24-Bit PRAM Data (Program Code), PDBx(23:0), can only be written to using the MOVEM instruction. During instruction fetching the PDBx Bus is routed to the Program Decode Controller of the DSP core for instruction decoding.

512 x 24-Bit Bootstrap ROM (PROM 256 x 24 Bit for DSP1)

This is a 512 x 24-Bit factory programmed Boot ROM used for storing the program sequence and for initializing the DSP. Essentially this consists of reading the data via I2C, SPI or EMI interface and store it in PRAM, XRAM, YRAM, and/or external DRAM.

Figure 17. DSP1 and DSP0 Memory Spaces

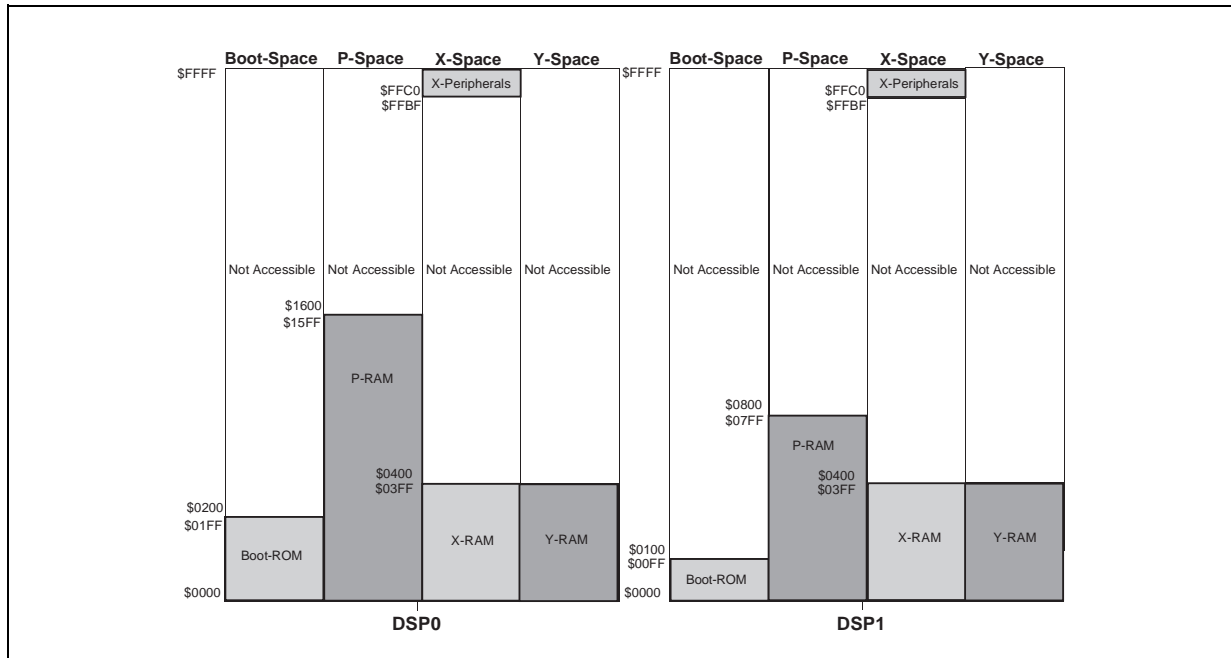

Serial Audio Interface (SAI)

The SAI is used to deliver digital audio to the DSPs from an external source. Once processed by the DSPs, it can be returned through this interface either sent to the DAC for D/A conversion. The features of the SAI are listed below.

- 3 Synchronized Stereo Data Transmission Lines
- 3 Synchronized Stereo Data Reception Lines
- Master and Slave operating mode: clock lines can be both master and slave.
- Receive and Transmit Data Registers have two locations to hold left and right data.

XCHG Interface (DSP to DSP Exchange Interface)

The Exchange Interface peripheral provides bidirectional communication between DSP0 and DSP1. Both 24 bit word data and four bit Flag data can be exchanged. A FIFO is utilized for received data. It minimizes the number of times an Exchange Interrupt Service Routine would have to be called if multi-word blocks of data were to be received. The Transmit FIFO is in effect the Receive FIFO of the other DSP and is written directly by the transmitting DSP. The features of the XCHG are listed below.

- 10 Word XCHG Receive FIFO on both DSPs
- Four Flags for each XCHG for DSP to DSP signaling
- Condition flags can optionally trigger interrupts on both DSPs

DRAM/SRAM Interface (EMI)

The External DRAM/SRAM Interface is viewed as a memory mapped peripheral. Data transfers are performed by moving data into/from data registers and the control is exercised by polling status flags in the control/status register or by servicing interrupts. An external memory write is executed by writing data into the EMI Data Write Register. An external memory read operation is executed by either writing to the offset register or reading the EMI Data Read Register, depending on the configuration.

TDA7500A

The features of the EMI are listed below.

- Data bus width fixed at 4 bits for DRAM and 8 bits for SRAM
- Data word length 16 or 24 bits for DRAM
- Data word length 8 or 16 or 24 bits for SRAM
- DRAM address lines means $2^{26} = 256\text{MB}$ addressable DRAM
- Refresh rate for DRAM can be chosen among eight divider factor
- SRAM relative addressing mode; $2^{22} = 4\text{MB}$ addressable SRAM
- Four SRAM Timing choices
- Two Read Offset Registers

Debug Interface

A dedicated Debug Port is available for each DSP Cores. The debug logic is contained in the core design of the DSP. The features of the Debug Port are listed below:

- Breakpoint Logic
- Trace Logic
- Single stepping
- Instruction Injection
- Program Disassembly

Serial Peripheral Interface

The DSP core requires a serial interface to receive commands and data over the LAN. During an SPI transfer, data is transmitted and received simultaneously. A serial clock line synchronizes shifting and sampling of the information on the two serial data lines. A slave select line allows individual selection of a slave SPI device.

When an SPI transfer occurs an 8-bit word is shifted out one data pin while another 8-bit character is simultaneously shifted in a second data pin. The central element in the SPI system is the shift register and the read data buffer. The system is single buffered in the transfer direction and double buffered in the receive direction.

I²C Interface

The inter Integrated Circuit bus is a single bidirectional two-wire bus used for efficient inter IC control. All I²C bus compatible devices incorporate an on-chip interface which allows them communicate directly with each other via the I²C bus.

Every component hooked up to the I2C bus has its own unique address whether it is a CPU, memory or some other complex function chip. Each of these chips can act as a receiver and /or transmitter on its functionality.

General Purpose Input/Output

The DSP requires a set of external general purpose input/output lines, and a reset line. These signals are used by external devices to signal events to the DSP. The GPIO lines are implemented as DSP 's peripherals. The GPIO lines are grouped in Port A which is connected to DSP 0, and Port B, which is connected to DSP1.

RDS

The RDS block is an hardware cell able to deliver the RDS frames through a dedicated serial interface. RDS quality signalis also available. This block needs to be initialised at reset by the DSP, after that it works in background and does not need any further DSP support. RDS is made of 57kHz filter, demodulator and decoder.

Asynchronous Sample Rate Converter

The ASRC, embedded in the TDA7500A, offers a fully digital stereo asynchronous sample rate conversion of digital audio sources to the TDA7500A's internal sample frequency. This solves the problem of mixing audio sources with different sample rates and doesn't need the "classical" approach of synchronizing the PLL.

As the usual internal sample rate of TDA7500A is around 48.51 kHz, the ASRC works with the common input signals only in upsampling mode. There is no need to explicitly program the input and output sample rates, as the ASRC solves this problem with an automatic Digital Ratio Locked Loop.

The ASRC is intended for applications up to 20 bit input word width. Digital Audio Sources can be applied in general Serial Audio Interface format (3 wires) as well as in AES/EBU, IEC and EIAJ CP-340 format (1 wire).

An interface to the DSP core offers the possibility of interrupt controlled sample delivery. Furthermore, a programmable Control/Status Register inside the ASRC allows a great variety of adjustments and status informations.

Figure 18. shows, how the ASRC interfaces the other blocks.

PLL Clock Oscillator

The PLL Clock Oscillator can accept an external clock at XTI or it can be configured to run an internal oscillator when a crystal is connected across pins XTI & XTO. There is an input divide block IDF (1 -> 32) at the XTI clock input and a multiply block MF (9 -> 128) in the PLL loop. Hence the PLL can multiply the external input clock by a ratio MF/IDF to generate the internal clock. This allows the internal clock to be within 1 MHz of any desired frequency even when XTI is much greater than 1 MHz. It is recommended that the input clock is not divided down to less than 1 MHz as this reduces the Phase Detector's update rate.

The clocks to the DSP can be selected to be either the VCO output divided by 2 to 16, or be driven by the XTI pin directly.

The crystal oscillator and the PLL will be gated off when entering the power-down mode (by setting a register on DSP0).

Figure 18. System Overview

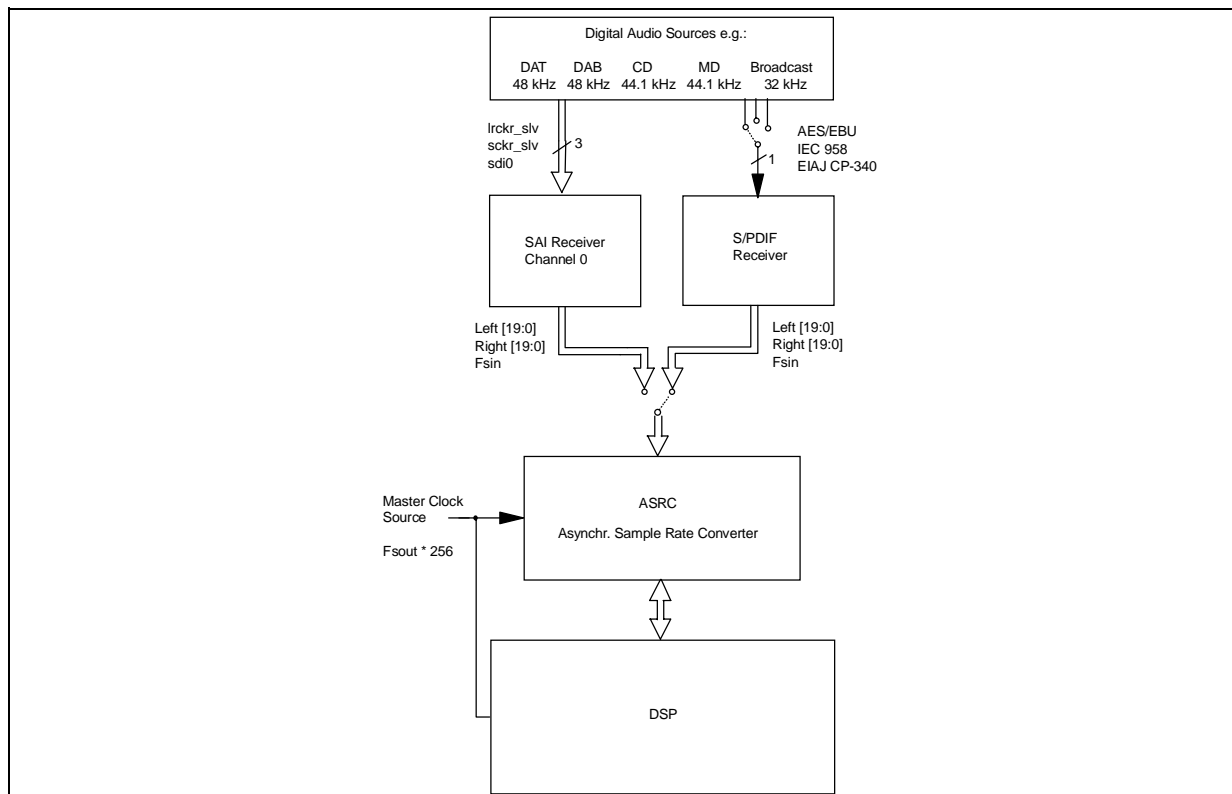

TDA7500A

Codec

The CODEC is composed of four AD mono converters, three DA stereo converters. The ADC can operate both in audio mode and in FM/AM mode. When in audio mode, it converts the audio bandwidth from 20 to 20KHz. The A to D is a third order Sigma-Delta converter, the converter resolutions is 20 bit with 88 dB of dynamic range and 85dB of total harmonic distortion. When in FM mode, the converted bandwidth is up to 192KHz. The D to A is a third order Sigma-Delta converter with a low noise reconstructing analog filter, the converter resolution is 20 bit with 93 dB of dynamic range and 85dB of total harmonic distortion. All the reference voltages are generated inside the chip.

Some capabilities of the CODEC are listed below:

- 20-Bit Resolution
- Digital Anti-Alias Filtering embedded
- Adjustable System Sampling Rates
- 93dB D/A Dynamic Range (Not-Weighted)88dB A/D Dynamic Range (Not-Weighted)
- 85dB D/A (THD+N/S)85dB A/D (THD+N/S)
- Internal Differential Analog Architecture
- +3.3V Power Supply

SOFTWARE FEATURES

A great flexibility is guaranteed by the two programmable DSP cores. A list of the main software functions which can be implemented in the TDA7500A is enclosed hereafter. A block diagram of the audio processing flow is shown in Fig. 19 below.

Figure 19. Software Block Diagram of Audio & Sound Processing

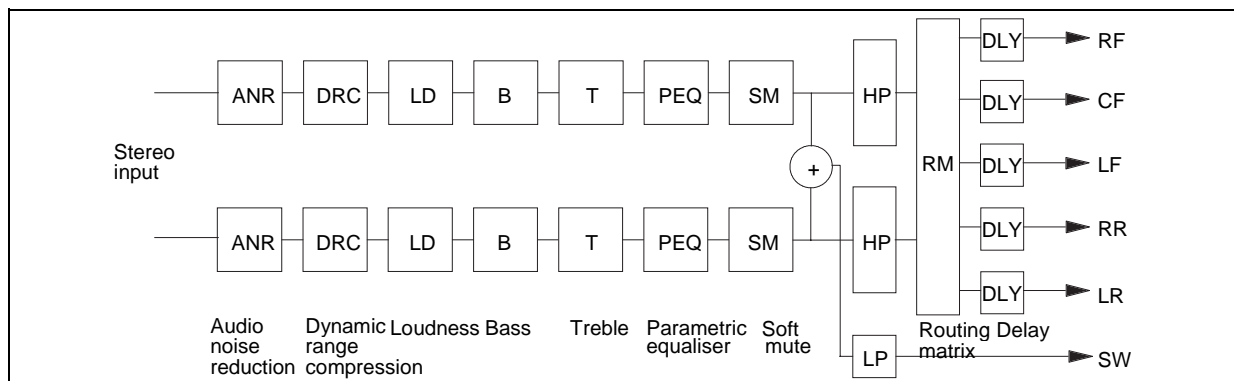

AM/FM Baseband Signal Processing

- FM weak signal processing
- Integrated 19 kHz MPX filter and deemphasis
- flexible noise cancellation
- flexible multipath detector

Generic Audio Signal Processing

- Loudness
- Bass, treble, fader control
- Volume control

- Distortion Limiting
- Premium Equalization
- Soft mute

TAPE Signal Processing

- Dolby B Noise Reduction
- Automatic Music Search

CD Signal Processing

- Dynamic Range Compression

Audiophile

- Parametric Equalization
- Crossover
- Channel Delays
- Center Channel Imaging Output
- Audio Noise Reduction

Other

- Voice compression/decompression for TIM storage
- Echo and noise cancelling for mobile phone connection

Application Scheme

The TDA7500A can operate as a standalone device either it can interface the TDA7501 which contains the analog input multiplexer, analog volume control and the line-driver. The FM_MPX and FM_LEVEL signals coming from the tuner and other signals supplied by analog sources are adapted by the TDA7501 and fed to the TDA7500A. A block diagram of the system is shown in Fig. 20 below.

The TDA7500A converts all the analog signals into digital domain and performs AM/FM processing and audio/sound processing. Thanks to this, it is possible to process any audio source as well analog as digital in parallel, to record FM mono for traffic information, telephone response, navigation and RDS. Finally the digital signals are D/A converted and sent to the TDA7501 for the final level adjustment and for the analog volume control.

TDA7500A

Figure 20. lock Diagram of Car Amplifier Audio Sub-System.

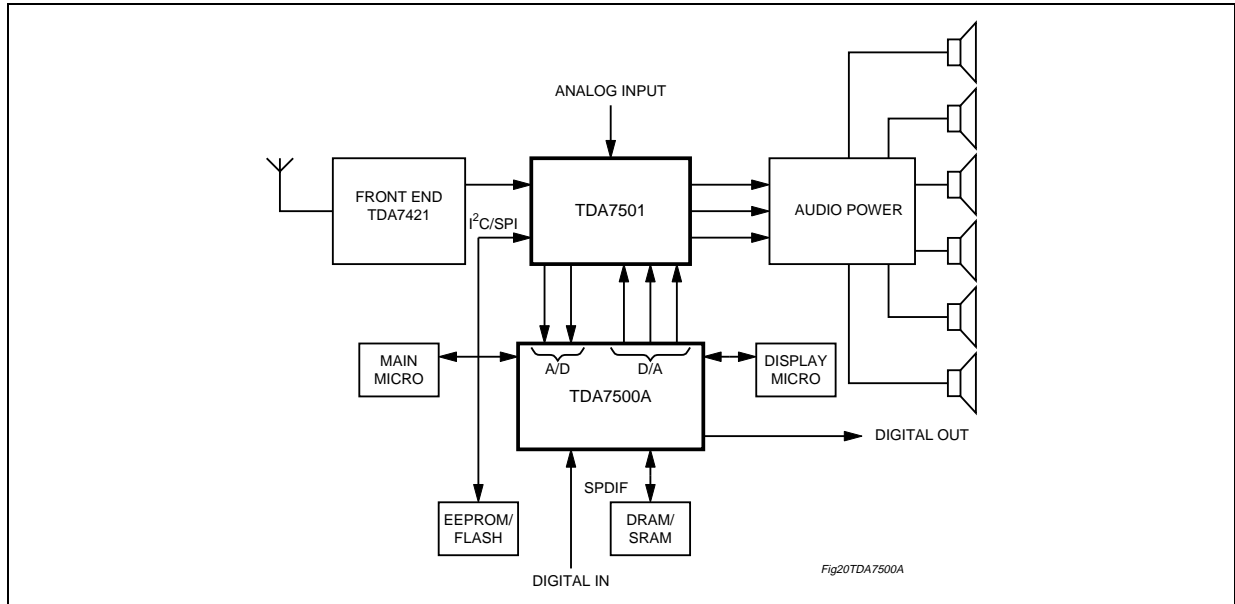

Clock Scheme

When TDA7500A is used in AD/FM mode the following scheme is chosen in order to avoid harmonics inside the FM band. Parts of the system are directly clocked by the crystal oscillator, whereas other parts are driven by the pll oscillator. Thanks to this it is possible to process any audio source as well analog as digital in parallel to record FM mono for traffic informations, telephone resp. navigation and RDS. Figure 21 shows the clock scheme. Regarding on the country and its FM bandwidth different crystals should be selected.

Figure 21. Clock Scheme

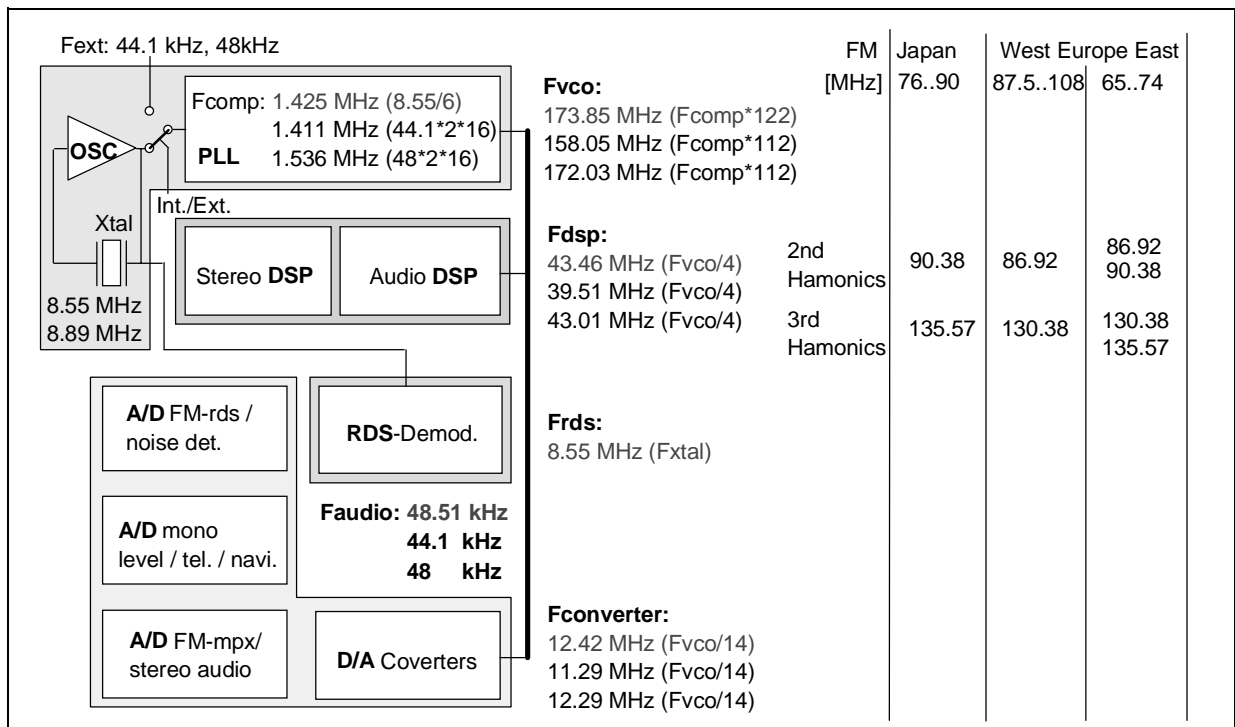

APPLICATION DIAGRAM

The application diagram shown on the next page must be considered as one of the examples of a (limited) application of the chip. For the real application set-up the application notes are necessary.

Figure 22. Application diagram.

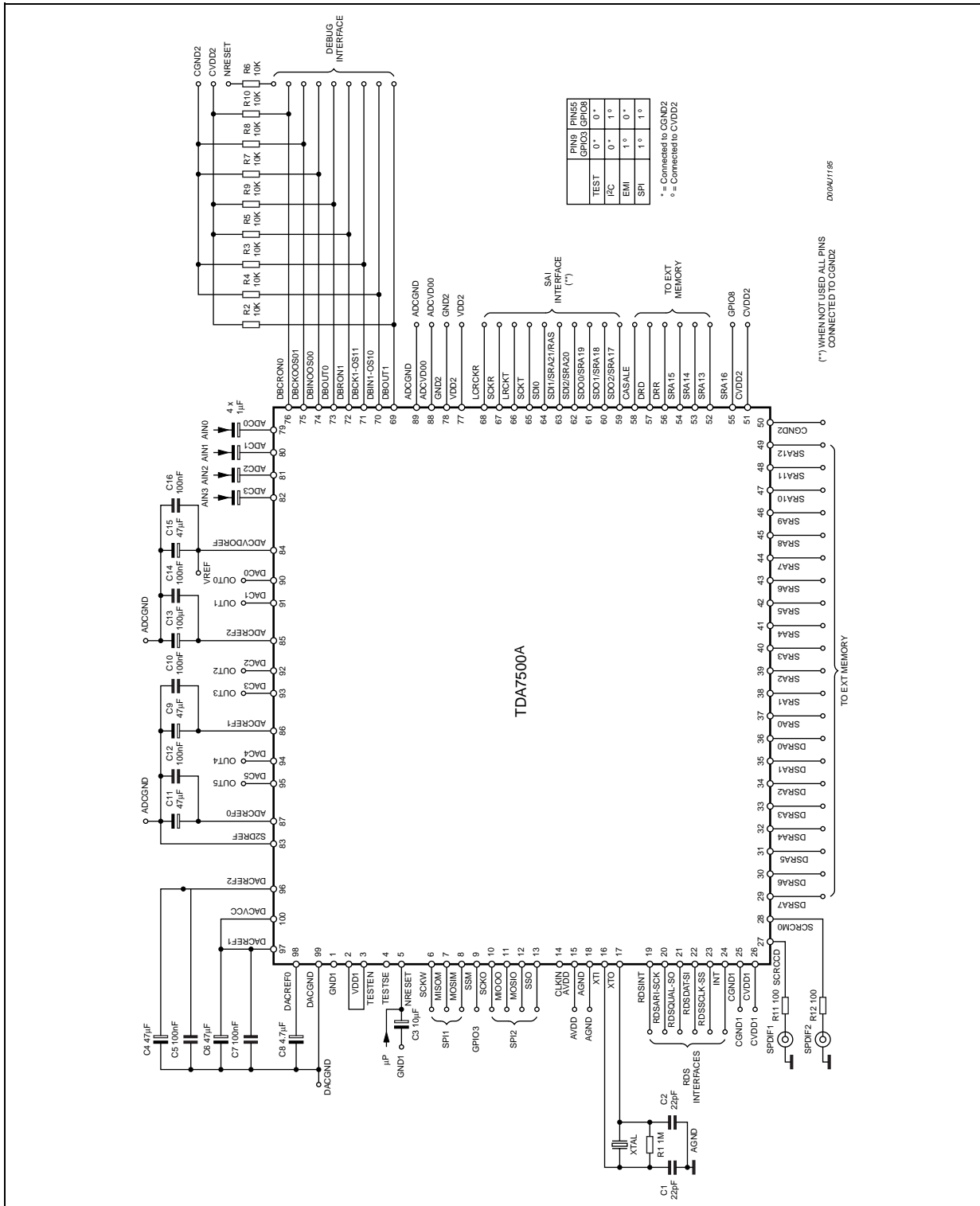

TDA7500A

PACKAGE MARKING

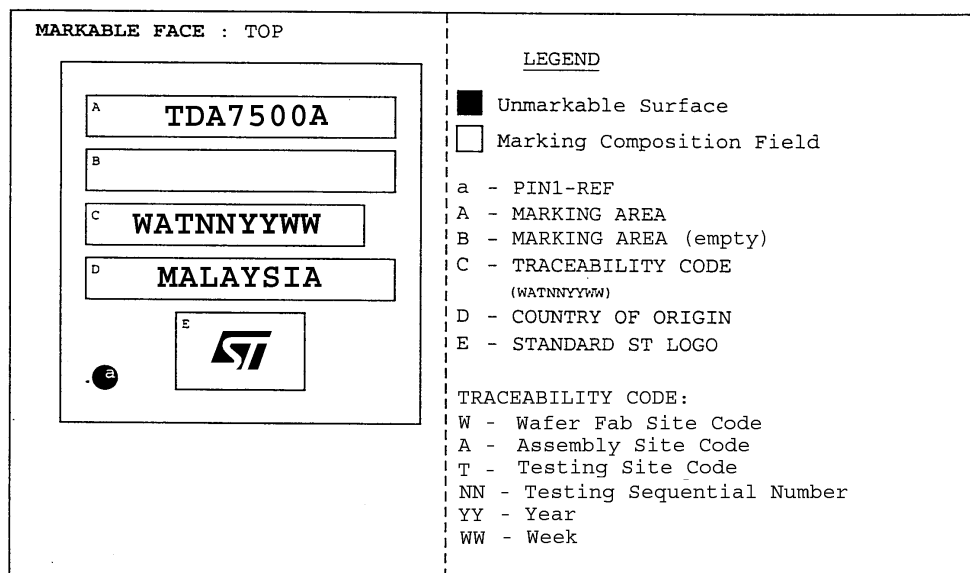

DIM.	mm			inch		
	MIN.	TYP.	MAX.	MIN.	TYP.	MAX.
A			1.60			0.063
A1	0.05		0.15	0.002		0.006
A2	1.35	1.40	1.45	0.053	0.055	0.057
B	0.17	0.22	0.27	0.007	0.009	0.011
C	0.09		0.20	0.003		0.008
D		16.00			0.630	
D1		14.00			0.551	
D3		12.00			0.472	
e		0.50			0.020	
E		16.00			0.630	
E1		14.00			0.551	
E3		12.00			0.472	
H		9.85			0.388	
L	0.45	0.60	0.75	0.018	0.024	0.030
L1		1.00			0.039	
S	8.80			0.346		
S1	8.80			0.346		
K	0° (min.), 3.5° (typ.), 7° (max.)					
ccc		0.080			0.003	

OUTLINE AND MECHANICAL DATA

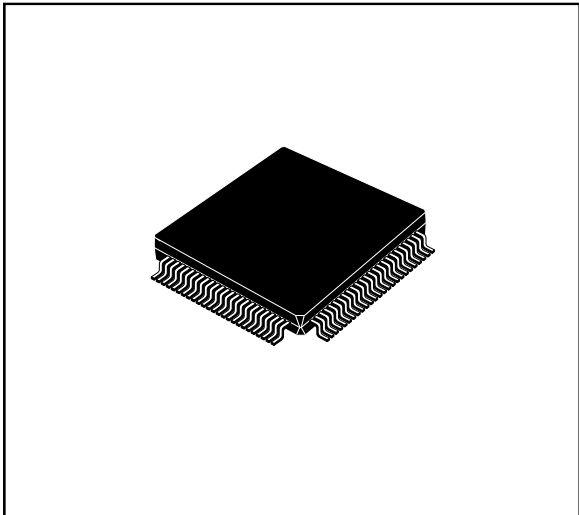

**TQFP100 (14x14x1.40mm)
with Slug Down (10x10mm)**

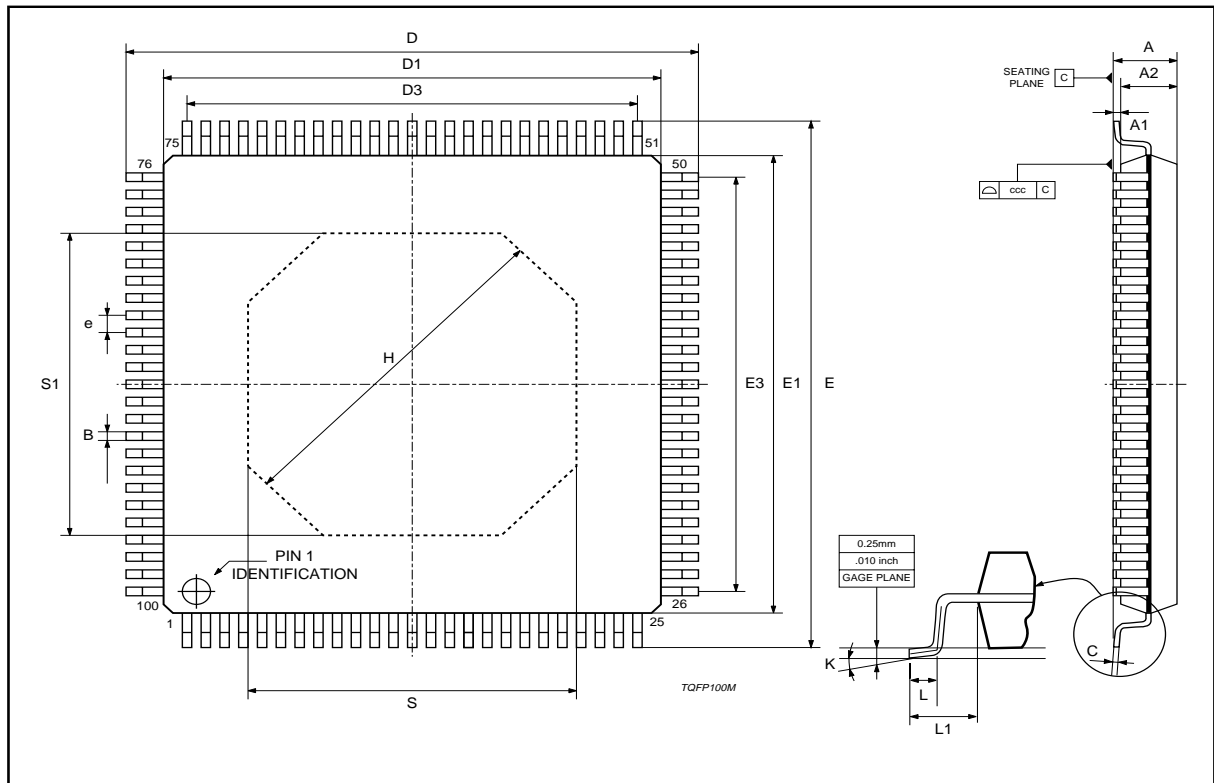

Information furnished is believed to be accurate and reliable. However, STMicroelectronics assumes no responsibility for the consequences of use of such information nor for any infringement of patents or other rights of third parties which may result from its use. No license is granted by implication or otherwise under any patent or patent rights of STMicroelectronics. Specifications mentioned in this publication are subject to change without notice. This publication supersedes and replaces all information previously supplied. STMicroelectronics products are not authorized for use as critical components in life support devices or systems without express written approval of STMicroelectronics.

The ST logo is a registered trademark of STMicroelectronics
© 2001 STMicroelectronics - All Rights Reserved

STMicroelectronics GROUP OF COMPANIES

Australia - Brazil - Canada - China - Finland - France - Germany - Hong Kong - India - Israel - Italy - Japan - Malaysia - Malta - Morocco -
Singapore - Spain - Sweden - Switzerland - United Kingdom - United States.

<http://www.st.com>