



TDA7502

IN-CAR REMOTE AMPLIFIER DSP

PRODUCT PREVIEW

- 24-Bit Fixed-point DSP core delivering up to 50 MIPS
- 2x512 x24 Bit of RAM for X and Y data memory.
- 1536 x 24 Bit of RAM for Program.
- 1536 x 24 Bit of Additional RAM memory usable for delay or program
- Serial Audio Interface.
- Debug Port.
- Control Interface for external GPIOs, Interrupts, and RESET.
- SPI and I²C for communication between external micro and DSP. Both master and slave operating modes.
- PLL Clock Oscillator
- 5V-tolerant 3V I/O interface

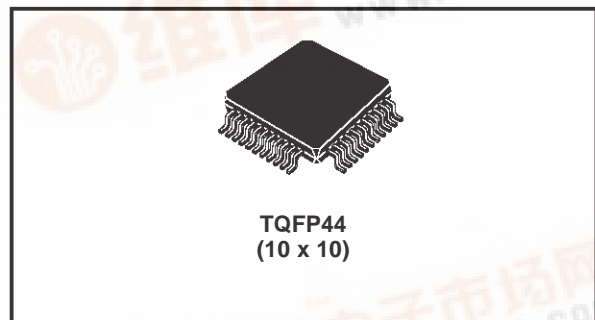

configurable PLL.

The computational power and the memory configuration make this device particularly suitable for in car equalisation. This device will offer the best trade-off between performance and cost when coupled with the TDA7531, or other devices of the same family. A library of sound processing functions is available for this device; some of these functions are: parametric equaliser, cross over filters, acoustic delay, dynamic compression, Vol/Bass/Treble/Fader, active equalisation, Stereo Spatial Enhancement.

DESCRIPTION

This device is a high-performance, fully programmable DSP, suitable for a wide range of applications and particularly for Audio and Sound Processing. It contains a 24-bit 50 MIPS DSP core, several interfaces for control and data, plus a

BLOCK DIAGRAM

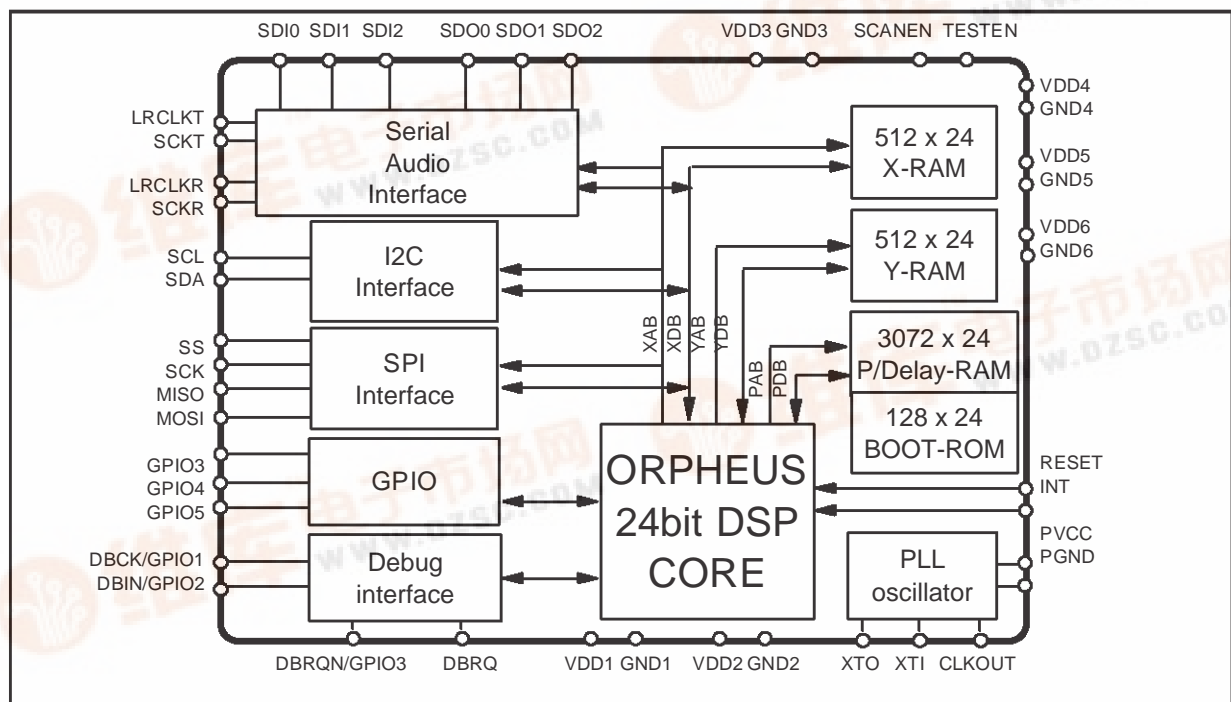

TDA7502

ABSOLUTE MAXIMUM RATINGS

Symbol	Parameter	Value	Unit
V _{DDC}	Core DC Supply voltage	4.6	V
V _{DDP}	Pads DC Supply voltage	4.6	V
V _I , V _{IN}	Digital or analog input voltage	-0.5 to (V _{DDP} +0.5)	V
T _{op}	Operative temperature range	-40 to 85	°C
T _{stg}	Storage temperature range (plastic)	-55 to 150	°C

PIN CONNECTION

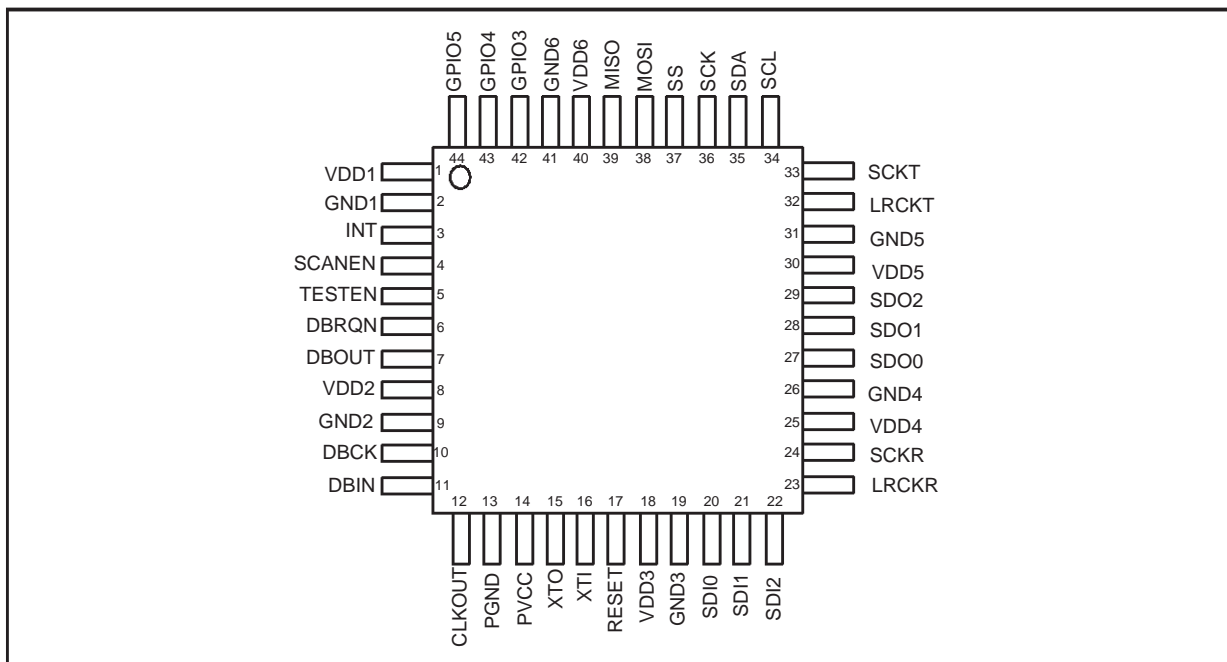

THERMAL DATA

Symbol	Parameter	Value	Unit
R _{th j-amb}	Thermal Resistance Junction to Ambient	50	°C/W

PIN DESCRIPTION

N.	Name	Type	Reset Status (1)	Function
1	VDD1	I	–	3.3V core supply.
2	GND1	I	–	Core ground.
3	INT	I/O	–	External interrupt line (Input/Output). When this line is asserted low, the DSP may be interrupted. Acts as IRQA line of DSP core.
4	SCANEN	I	–	SCAN Enable When active with TESTEN also active, controls the shifting of the internal scan chains.
5	TESTEN	I	–	Test Enable. When active, puts the chip into test mode and muxes the XTI clock to all flip-flops. When SCANEN is also active, the scan chain shifting
6	DBRQN	I	–	Debug Port Request Input. Means of entering the Debug mode of operation.

PIN DESCRIPTION (continued)

N.	Name	Type	Reset Status	Function
7	DBOUT/GPIO2	I/O	I	The serial data output for the Debug Port. Can also be used as a GPIO.
8	VDD2	I	–	3.3V core supply.
9	GND2	I	–	Core ground.
10	DBCK/GPIO0	I/O	I	Debug Port Bit Clock/Chip Status 1. The serial clock for the Debug Port is provided when an input. When an output, provides information about the chip status. Can also be used as GPIO
11	DBIN/GPIO1	I/O	I	Debug Port Serial Input/Chip Status 0. The serial data input for the Debug Port is provided when an input. When an output, provides information about the chip status. Can also be used as GPIO.
12	CLKOUT	O	–	Output Clock.
13	PGND	I	–	PLL Clock Ground Input. Ground connection for oscillator circuit.
14	PVCC	I	–	PLL Clock Power Supply. Positive supply for PLL Clock Oscillator.
15	XTO	O	High	Crystal Oscillator Output. Crystal Oscillator output drive.
16	XTI	I	–	Crystal Oscillator Input. External Clock Input or crystal connection.
17	RESET	I/O	I	System Reset. A logic low level applied to RESET input initializes DSPs. During Debug Mode if this pin is pulled low in while the DBRQN line is pulled low then the DSP pointed to by the DBSEL pin will be reset.
18	VDD3	I	–	3.3V Supply.
19	GND3	I	–	Ground.
20	SDI0	I	–	SDI0 is a stereo digital audio data input pin channel 0.
21	SDI1	I	–	SDI1 is a stereo digital audio data input pin channel 1.
22	SDI2	I	–	SDI2 is a stereo digital audio data input pin channel 2.
23	SCKR	I/O	–	SAI receive bit clock. Master or slave.
24	LRCKR	I/O	–	Left-Right clock for SAI Receiver. Master or slave.
25	VDD4	I	–	3.3V Supply.
26	GND4	I	–	Ground.
27	SDO0	O	High	SDO0 is a stereo digital audio data output pin channel 0.
28	SDO1	O	High	SDO1 is a stereo digital audio data output pin channel 1.
29	SDO2	O	High	SDO2 is a stereo digital audio data pin channel 2.
30	VDD5	GND	–	3.3V Supply.
31	GND5	I	–	Ground.
32	LRCKT	I/O	–	SAI transmit left/right clock. Master or slave.
33	SCKT	I/O	–	SAI transmit bit clock. Master or slave.
34	SCL	I/O	–	Clock line for I ² C bus. Schmitt trigger input.
35	SDA	I/O	–	Data line for I ² C bus. Schmitt trigger input.
36	SCK	I	–	Bit clock for SPI control interface.
37	SS	I	–	Slave select input pin for SPI control interface.
38	MOSI	I/O	I	Serial Data Output for SPI type serial port when in SPI Master Mode and Serial Data Input when in SPI Slave Mode.
39	MISO	I/O	I	Serial Data Input for SPI style serial port when in SPI Master Mode and Serial Data Output when in SPI Slave Mode.
40	VDD6	GND	–	3.3V Supply.
41	GND6	I	–	Ground.
42	GPIO3	I/O	–	This pin is dedicated as general I/O.
43	GPIO4	I/O	–	This pin is dedicated as general I/O.
44	GPIO5	I/O	–	This pin is dedicated as general I/O.

RECOMMENDED DC OPERATING CONDITIONS

Symbol	Parameter	Test Condition	Min.	Typ.	Max.	Unit
V _{DDC}	3.3V Power Supply Voltage		3	3.3	3.6	V
T _j	Operating Junction Temperature		-40		125	°C

POWER CONSUMPTION

Symbol	Parameter	Value	Unit
I _{dd}	Maximum current for core power supply @3.3V	250	mA

Note: 50MHz internal DSP clock at T_{amb}

FUNCTIONAL DESCRIPTION

The TDA7502 contains one DSP Core and associated peripherals.

24-BIT DSP CORE.

The DSP core is used to process the converted analog audio data coming from the CODEC chip via the SAI and return it for analog conversion. Functions such as volume, tone, balance, and fader control, as well as spatial enhancement and general purpose signal processing may be performed by the DSP.

Some capabilities of the DSPs are listed below:

- Single cycle multiply and accumulate with convergent rounding and condition code generation
- 2 x 56-bit Accumulators
- Double precision multiply
- Scaling and saturation arithmetic
- 48-bit or 2 x 24-bit parallel moves
- 64 interrupt vector locations
- Fast or long interrupts possible
- Programmable interrupt priorities and masking
- 8 each of Address Registers, Address Offset Registers and Address Modulo Registers
- Linear, Reverse Carry, Multiple Buffer Modulo, Multiple Wrap-around Modulo address arithmetic
- Post-increment or decrement by 1 or by offset, Index by offset, predecrement address
- Repeat instruction and zero overhead DO loops
- Hardware stack capable of nesting combinations of 7 DO loops or 15 interrupts/subroutines
- Bit manipulation instructions possible on all registers and memory locations. Also Jump on bit test.
- 4 pin serial debug interface
- Debug access to all internal registers, buses

and memory locations

- 5 word deep program address history FIFO
- Hardware and software breakpoints for both program and data memory accesses
- Debug Single stepping, Instruction injection and Disassembly of program memory

DSP PERIPHERALS

There are a number of peripherals that are tightly coupled to the DSP Core. Each of the peripherals are listed below and described in the following sections.

- 512 x 24-Bit X-RAM.
- 512 x 24-Bit Y-RAM.
- 3072 x 24-Bit Program RAM
- 128 x 24-Bit Boot ROM.
- Serial Audio Interface (SAI)
- Single Debug Port
- Programmable Control Interface (SPI/I²C)
- GPIO

DATA AND PROGRAM MEMORY

Each of the memories are described below.

512 x 24-Bit X-RAM (XRAM)

This is a 512 x 24-Bit Single Port SRAM used for storing coefficients. The 16-Bit XRAM address, XABx(15:0) is generated by the Address Generation Unit of the DSP core. The 24-Bit XRAM Data, XDBx(23:0), may be written to and read from the Data ALU of the DSP core. The XDBx Bus is also connected to the Internal Bus Switch so that it can be routed to and from all peripheral blocks.

512 x 24 Bit Y-RAM (YRAM)

This is a 512 x 24-Bit Single Port SRAM used for storing coefficients. The 16-Bit address, YABx(15:0) is generated by the Address Generation Unit of the DSP core. The 24-Bit Data, YDBx(23:0), is written to and read from the Data

ALU of the DSP core. The YDBx Bus is also connected to the Internal Bus Switch so that it can be routed to and from other blocks.

3072 X 24-Bit Program RAM

This is a 3072 x 24-Bit Single Port SRAM used for storing and executing program code. The 16-Bit PRAM Address, PABx(15:0) is generated by the Program Address Generator of the DSP core for Instruction Fetching, and by the AGU in the case of the Move Program Memory (MOVEM) Instruction. The 24-Bit PRAM Data (Program Code), PDBx(23:0), can only be written to using the MOVEM instruction.

During instruction fetching the PDBx Bus is routed to the Program Decode Controller of the DSP core for instruction decoding.

Spare space in the Program area may be used as data memory to implement delay lines for example.

128 x 24-Bit Bootstrap ROM (PROM)

This is a 128 x 24-Bit factory programmed Boot ROM used for storing the program sequence for initializing the DSP.

Essentially this consists of a routine that is called when the DSP comes out of reset. There are three different boot modes supported by the boot ROM, one boots directly into PRAM, the second boots over the I²C bus and the third boots are the SPI bus. The boot mode is selected by the levels on GPIO3 and GPIO5

Serial Audio Interface (SAI)

The SAI is used to deliver digital audio to the DSPs from an external source. Once processed by the DSPs, it can be returned through this interface. The features of the SAI are listed below.

- Three Synchronized Stereo Data Transmission Lines
- Three Synchronized Stereo Data Reception Lines
- Master/Slave operating modes
- Transmit and Receive Interrupt Logic triggers on Left/Right data pairs
- Receive and Transmit Data Registers have two locations to hold left and right data.

Serial Peripheral Interface

The DSP core requires a serial interface to receive commands and data over the LAN. During an SPI transfer, data is transmitted and received

simultaneously. A serial clock line synchronizes shifting and sampling of the information on the two serial data lines. A slave select line allows individual selection of a slave SPI device.

When an SPI transfer occurs an 8-bit word is shifted out one data pin while another 8-bit character is simultaneously shifted in a second data pin.

The central element in the SPI system is the shift register and the read data buffer. The system is single buffered in the transfer direction and double buffered in the receive direction.

I²C Interface

The Inter Integrated Circuit bus is a single bidirectional two-wire bus used for efficient inter IC control. All I²C bus compatible devices incorporate an on-chip interface which allows them communicate directly with each other via the I²C bus.

Every component hooked up to the I²C bus has its own unique address whether it is a CPU, memory or some other complex function chip. Each of these chips can act as a receiver and/or transmitter on its functionality.

General Purpose Input/Output

The DSP requires a set of external general purpose input/output lines, and a reset line. These signals are used by external devices to signal events to the DSP. The GPIO lines are implemented as DSP's peripherals

PLL Clock Oscillator

The PLL Clock Oscillator can accept an external clock at XTI or it can be configured to run an internal oscillator when a crystal is connected across pins XTI & XTO. There is an input divide block IDF (1 -> 32) at the XTI clock input and a multiply block MF (33 -> 128) in the PLL loop. Hence the PLL can multiply the external input clock by a ratio MF/IDF to generate the internal clock. This allows the internal clock to be within 1 MHz of any desired frequency even when XTI is much greater than 1 MHz. It is recommended that the input clock is not divided down to less than 1 MHz as this reduces the Phase Detector's update rate.

The clocks to the DSP can be selected to be either the VCO output divided by 2 or 4 respectively, or be driven by the XTI pin directly.

The crystal oscillator and the PLL will be gated off when entering the power-down mode (by setting bit 1 of the PCON Register).

TDA7502

Application Scheme

The TDA7502 IC will interface with an external CODEC chip (i.e. the TDA7531). The CODEC chip contains A/D converters that convert the audio data and send it to the TDA7502 IC for sig-

nal processing. The TDA7502 then sends the processed audio data back to the CODEC for D/A conversion. A block diagram of the system is shown in Fig. 1 below.

Figure 1. Block Diagram of Car Amplifier Audio Sub-System.

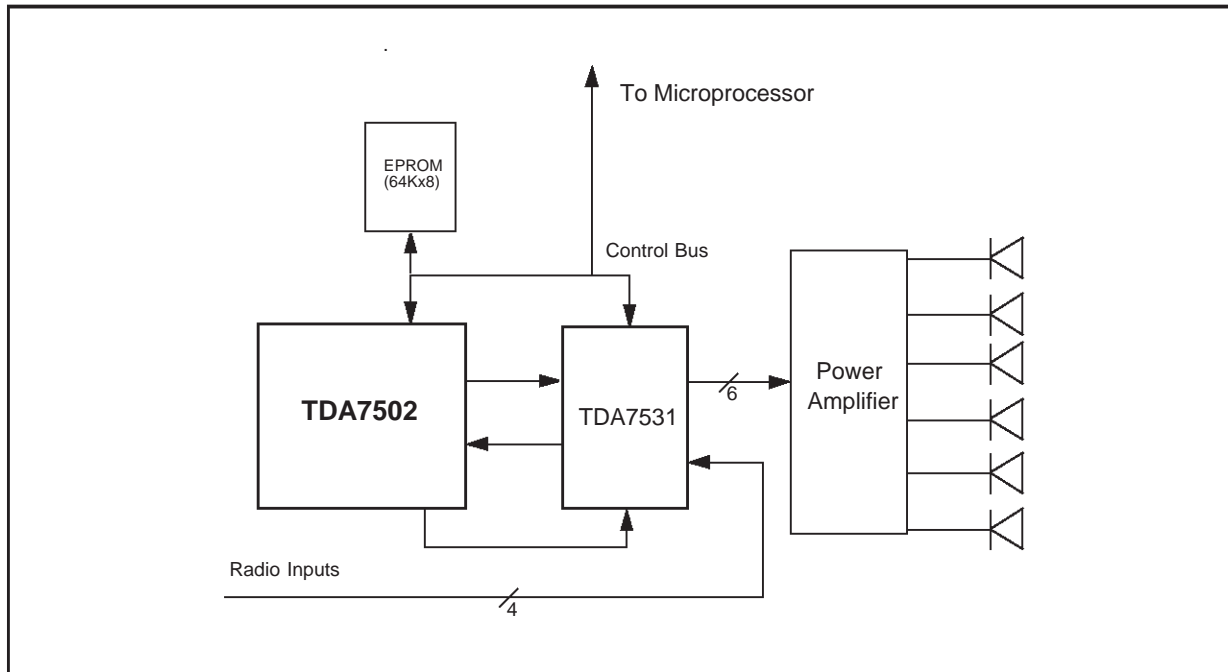

DIM.	mm			inch		
	MIN.	TYP.	MAX.	MIN.	TYP.	MAX.
A			1.60			0.063
A1	0.05		0.15	0.002		0.006
A2	1.35	1.40	1.45	0.053	0.055	0.057
B	0.30	0.37	0.45	0.012	0.014	0.018
C	0.09		0.20	0.004		0.008
D		12.00			0.472	
D1		10.00			0.394	
D3		8.00			0.315	
e		0.80			0.031	
E		12.00			0.472	
E1		10.00			0.394	
E3		8.00			0.315	
L	0.45	0.60	0.75	0.018	0.024	0.030
L1		1.00			0.039	
K	0°(min.), 3.5°(typ.), 7°(max.)					

OUTLINE AND MECHANICAL DATA

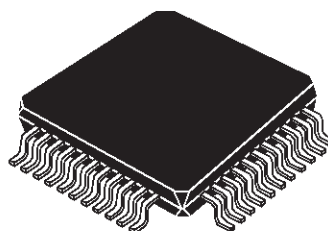

TQFP44 (10 x 10)

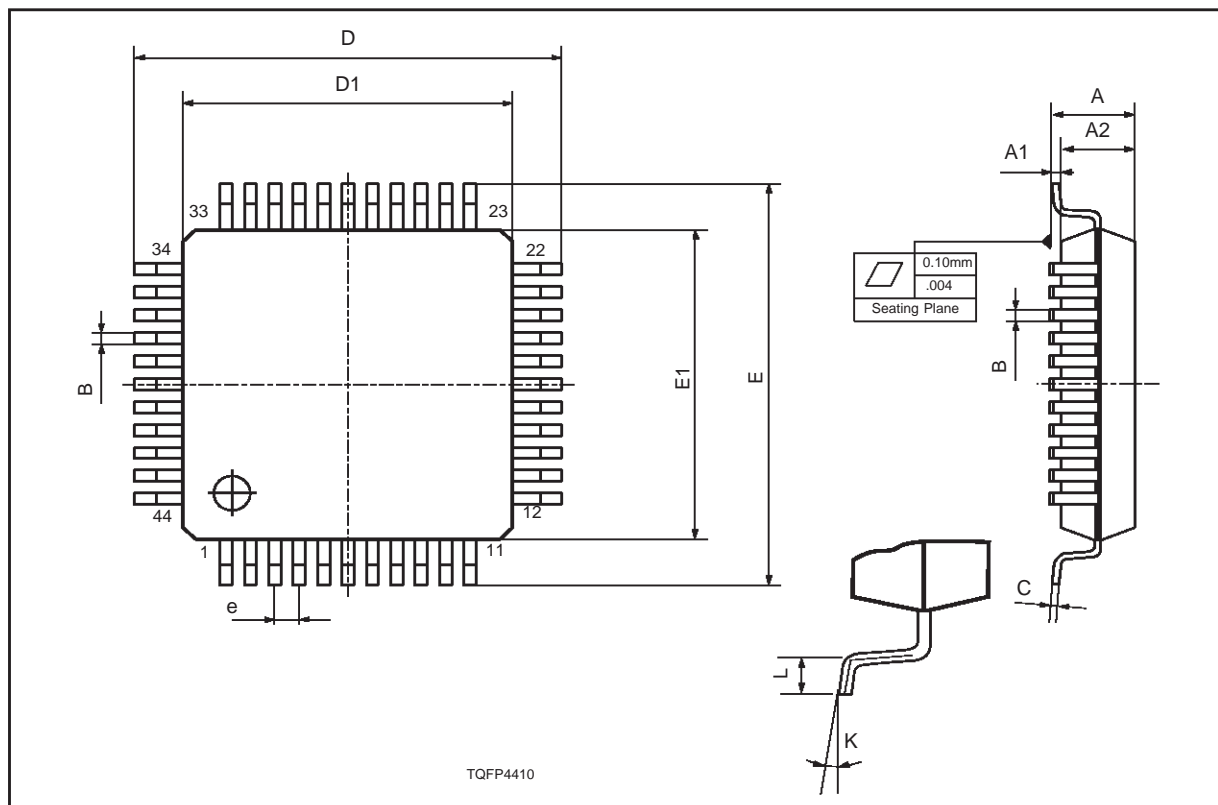

Information furnished is believed to be accurate and reliable. However, STMicroelectronics assumes no responsibility for the consequences of use of such information nor for any infringement of patents or other rights of third parties which may result from its use. No license is granted by implication or otherwise under any patent or patent rights of STMicroelectronics. Specification mentioned in this publication are subject to change without notice. This publication supersedes and replaces all information previously supplied. STMicroelectronics products are not authorized for use as critical components in life support devices or systems without express written approval of STMicroelectronics.

The ST logo is a registered trademark of STMicroelectronics

© 1999 STMicroelectronics – Printed in Italy – All Rights Reserved

STMicroelectronics GROUP OF COMPANIES

Australia - Brazil - Canada - China - France - Germany - Italy - Japan - Korea - Malaysia - Malta - Mexico - Morocco - The Netherlands - Singapore - Spain - Sweden - Switzerland - Taiwan - Thailand - United Kingdom - U.S.A.

<http://www.st.com>