



Polymer Chip Capacitor

TOPcap – 125 °C

Series/Type: B761

Date: June 2005
Version: 1





The following applies to all products named in this publication:

1. Some parts of this publication contain **statements about the suitability of our products for certain areas of application**. These statements are based on our knowledge of typical requirements that are often placed on our products in the areas of application concerned. We nevertheless expressly point out **that such statements cannot be regarded as binding statements about the suitability of our products for a particular customer application**. As a rule, EPCOS is either unfamiliar with individual customer applications or less familiar with them than the customers themselves. For these reasons, it is always ultimately incumbent on the customer to check and decide whether an EPCOS product with the properties described in the product specification is suitable for use in a particular customer application.
2. We also point out that **in individual cases, a malfunction of passive electronic components or failure before the end of their usual service life cannot be completely ruled out in the current state of the art, even if they are operated as specified**. In customer applications requiring a very high level of operational safety and especially in customer applications in which the malfunction or failure of a passive electronic component could endanger human life or health (e.g. in accident prevention or life-saving systems), it must therefore be ensured by means of suitable design of the customer application or other action taken by the customer (e.g. installation of protective circuitry or redundancy) that no injury or damage is sustained by third parties in the event of malfunction or failure of a passive electronic component.
3. **The warnings, cautions and product-specific notes must be observed.**
4. In order to satisfy certain technical requirements, **some of the products described in this publication may contain substances subject to restrictions in certain jurisdictions (e.g. because they are classed as “hazardous”)**. Useful information on this will be found in our Material Data Sheets on the Internet (www.epcos.com/material). Should you have any more detailed questions, please contact our sales offices.
5. We constantly strive to improve our products. Consequently, **the products described in this publication may change from time to time**. The same is true of the corresponding product specifications. Please check therefore to what extent product descriptions and specifications contained in this publication are still applicable before or when you place an order.

We also **reserve the right to discontinue production and delivery of products**. Consequently, we cannot guarantee that all products named in this publication will always be available.

6. Unless otherwise agreed in individual contracts, **all orders are subject to the current version of the “General Terms of Delivery for Products and Services in the Electrical Industry” published by the German Electrical and Electronics Industry Association (ZVEI)**.
7. The trade names EPCOS, CeraDiode, CSSP, PhaseCap, PhaseMod, SIFI, SIKOREL, SilverCap, SIMID, SIOV, SIP5D, SIP5K, TOPcap, UltraCap, WindCap are **trademarks registered or pending** in Europe and in other countries. Further information will be found on the Internet at www.epcos.com/trademarks.

Features

- Ultra-low ESR: $ESR_{max} = 35 \text{ m}\Omega \dots 55 \text{ m}\Omega$
- Ripple current up to 2.2 A_{RMS} @ 20 °C, 100 kHz
- Operating voltage 2.5 V ... 10 V
- Capacitance 100 μF ... 470 μF ($\pm 20\%$)
- Only 20% derating necessary
- Lead-free & RoHS compatible
- Temperature range: -55 °C ... 125 °C
- 100% surge current tested

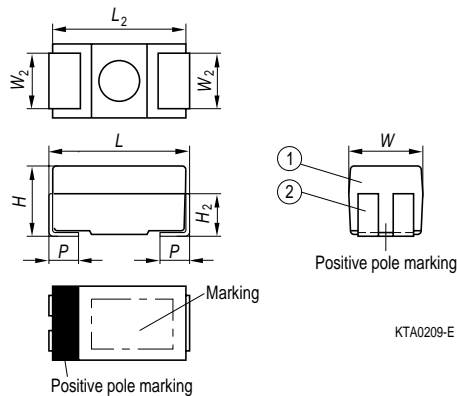
Dimensional drawing

- ① Encapsulation: molded epoxy resin
- ② NiFe; tinned surface Sn100

Case size		Dimensions in mm (inches)						
EPCOS	EIA/ IECQ	L	W	H	L ₂ typ.	W ₂ ± 0.1 ± (.004)	H ₂ typ.	P ± 0.3 ± (.012)
D	7343-31	7.3 ± 0.3 (.287 ± 0.012)	4.3 ± 0.3 (.169 ± 0.012)	2.8 ± 0.3 (.110 ± .012)	7.1 (.280)	2.4 (.094)	1.6 (.062)	1.3 (.051)
E	7343-43	7.3 ± 0.3 (.287 ± 0.012)	4.3 ± 0.3 (.169 ± 0.012)	4.0 ± 0.3 (.157 ± .012)	7.1 (.280)	2.4 (.094)	1.6 (.062)	1.3 (.051)



Polymer chip capacitors

B761

TOPcap – 125 °C

Ordering code structure

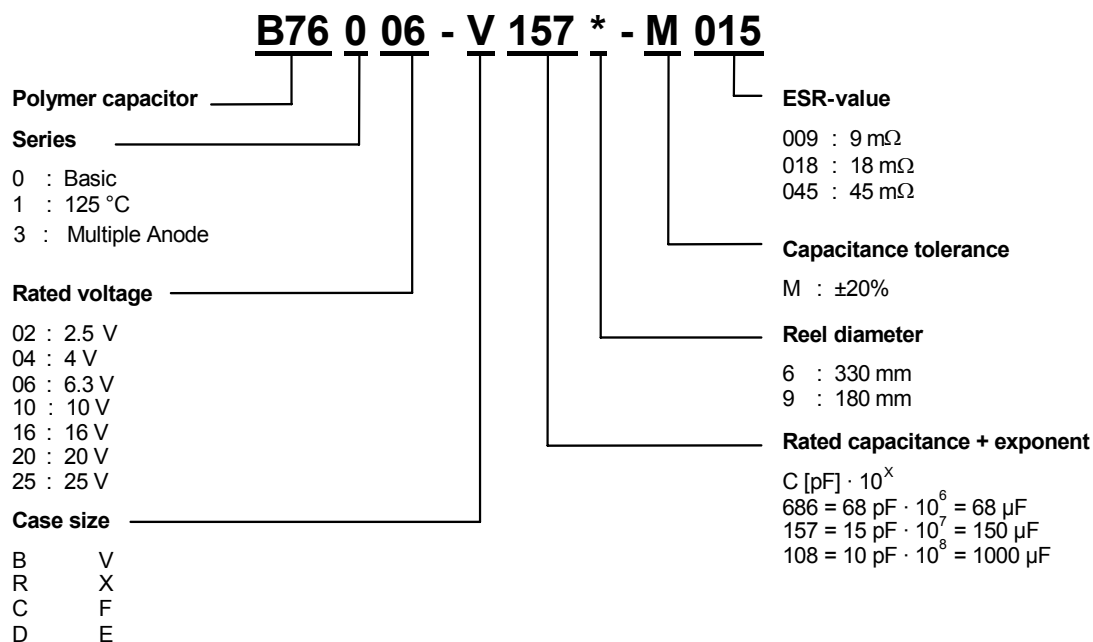

Technical data and ordering codes

Rated voltage V _R up to 85 °C (up to 125 °C) VDC	Rated capacitance C _R μF	Case size	EIA code	DF _{max} (20 °C, 120 Hz) %	Leakage current I _{leak, max} (20 °C, V _R , 5 min) μA	ESR _{max} ¹⁾ (20 °C, 100 kHz) mΩ	Ripple current			Ordering code
							I _{ACmax} (100 kHz) A _{RMS} 20 °C	85 °C	105 °C	
2.5 (2.0)	330	D	7343-31	10	83	40	1.9	1.7	0.8	B76102D3379M040
	470	D	7343-31	10	118	40	2.0	1.8	0.8	B76102D4779M040
4 (3.2)	220	D	7343-31	10	88	40	1.9	1.7	0.8	B76104D2279M040
	220	D	7343-31	10	88	45	1.8	1.6	0.7	B76104D2279M040
	330	D	7343-31	10	132	40	1.9	1.7	0.8	B76104D3379M040
	470	D	7343-31	10	188	40	1.9	1.7	0.8	B76104D4779M040
6.3 (5.0)	220	D	7343-31	10	139	40	1.9	1.7	0.8	B76106D2279M040
	330	D	7343-31	10	208	40	1.9	1.7	0.8	B76106D3379M040
	330	E	7343-43	10	208	40	2.0	1.8	0.8	B76106E3379M040
	470	E	7343-43	10	296	35	2.2	2.0	0.9	B76106E4779M035
10 (8.0)	100	D	7343-31	10	100	55	1.7	1.5	0.7	B76110D1079M055
	220	E	7343-43	10	220	40	2.0	1.8	0.8	B76110E2279M040
	330	E	7343-43	10	330	40	2.0	1.8	0.8	B76110E3379M040

¹⁾ other values upon request



中发网 WWW.ZFA.CN

全球最大的PDF中文下载站



中发网
www.zfa.cn

PDF 资料下载尽在中发网