

Power Distribution Controllers

This family of fully featured hot swap power controllers targets applications in the +2.5V to +12V range. The ISL6115 is for +12V control, the ISL6116 for +5V, the ISL6117 for +3.3V and the ISL6120 for +2.5V control applications. Each has a hard wired undervoltage (UV) monitoring and reporting threshold level approximately 80% of the aforementioned voltage.

The ISL6115 has an integrated charge pump allowing control of up to +16V rails using an external N-Channel MOSFET whereas the other devices utilize the +12V bias voltage to fully enhance the N-channel pass FET. All ICs feature programmable overcurrent (OC) detection, current regulation (CR) with time delay to latch off and soft start.

The current regulation level is set by 2 external resistors; R_{ISET} sets the CR V_{th} and the other is a low ohmic sense element across which the CR V_{th} is developed. The CR duration is set by an external capacitor on the CTIM pin which is charged with a 20 μ A current once the CR V_{th} level is reached. If the voltage on the CTIM cap reaches 1.9V the IC then quickly pulls down the GATE output latching off the pass FET.

This family although designed for high side switch control the ISL6116, ISL6117, ISL6120 can also be used in a low side configuration for control of much higher voltage potentials.

Ordering Information

PART NUMBER	PART MARKING	TEMP. RANGE (°C)	PACKAGE	PKG. DWG. #
ISL6115CB*	ISL6115CB	0 to 85	8 Ld SOIC	M8.15
ISL6116CB*	ISL6116CB	0 to 85	8 Ld SOIC	M8.15
ISL6117CB	ISL6117CB	0 to 85	8 Ld SOIC	M8.15
ISL6120CB	ISL6120CB	0 to 85	8 Ld SOIC	M8.15
ISL6115CBZA (Note)	6115CBZ	0 to 85	8 Ld SOIC (Pb-free)	M8.15
ISL6116CBZA (Note)	6116CBZ	0 to 85	8 Ld SOIC (Pb-free)	M8.15
ISL6117CBZA (Note)	6117CBZ	0 to 85	8 Ld SOIC (Pb-free)	M8.15
ISL6120CBZA (Note)	6120CBZ	0 to 85	8 Ld SOIC (Pb-free)	M8.15

Add "-T" suffix for tape and reel.

NOTE: Intersil Pb-free products employ special Pb-free material sets; molding compounds/die attach materials and 100% matte tin plate termination finish, which is compatible with both SnPb and Pb-free soldering operations. Intersil Pb-free products are MSL classified at Pb-free peak reflow temperatures that meet or exceed the Pb-free requirements of IPC/JEDEC J Std-020B.

Features

- HOT SWAP Single Power Distribution Control (ISL6115 for +12V, ISL6116 for +5V, ISL6117 for +3.3V and ISL6120 for +2.5V)
- Overcurrent Fault Isolation
- Programmable Current Regulation Level
- Programmable Current Regulation Time to Latch-Off
- Rail to Rail Common Mode Input Voltage Range (ISL6115)
- Internal Charge Pump Allows the use of N-Channel MOSFET for +12V control (ISL6115)
- Undervoltage and Overcurrent Latch Indicators
- Adjustable Turn-On Ramp
- Protection During Turn On
- Two Levels of Overcurrent Detection Provide Fast Response to Varying Fault Conditions
- 1 μ s Response Time to Dead Short
- Pb-Free Plus Anneal Available (RoHS Compliant)
- Tape & Reel Packing with '-T' Part Number Suffix

Applications

- Power Distribution Control
- Hot Plug Components and Circuitry

Pinout

ISL6115, ISL6116, ISL6117, ISL6120 (SOIC)
TOP VIEW

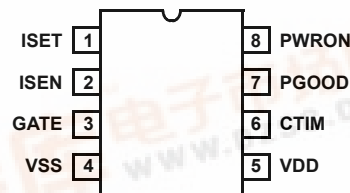

ISL6115, ISL6116, ISL6117, ISL6120

Application One - High Side Controller

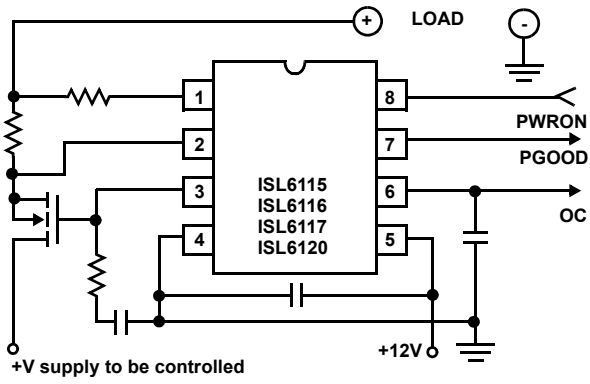

Application Two - Low Side Controller

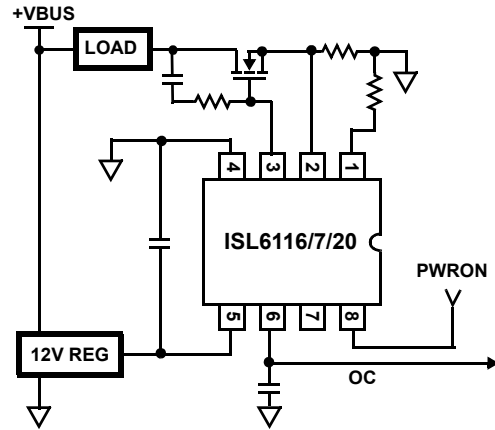

ISL6115, ISL6116, ISL6117, ISL6120

Simplified Block Diagram

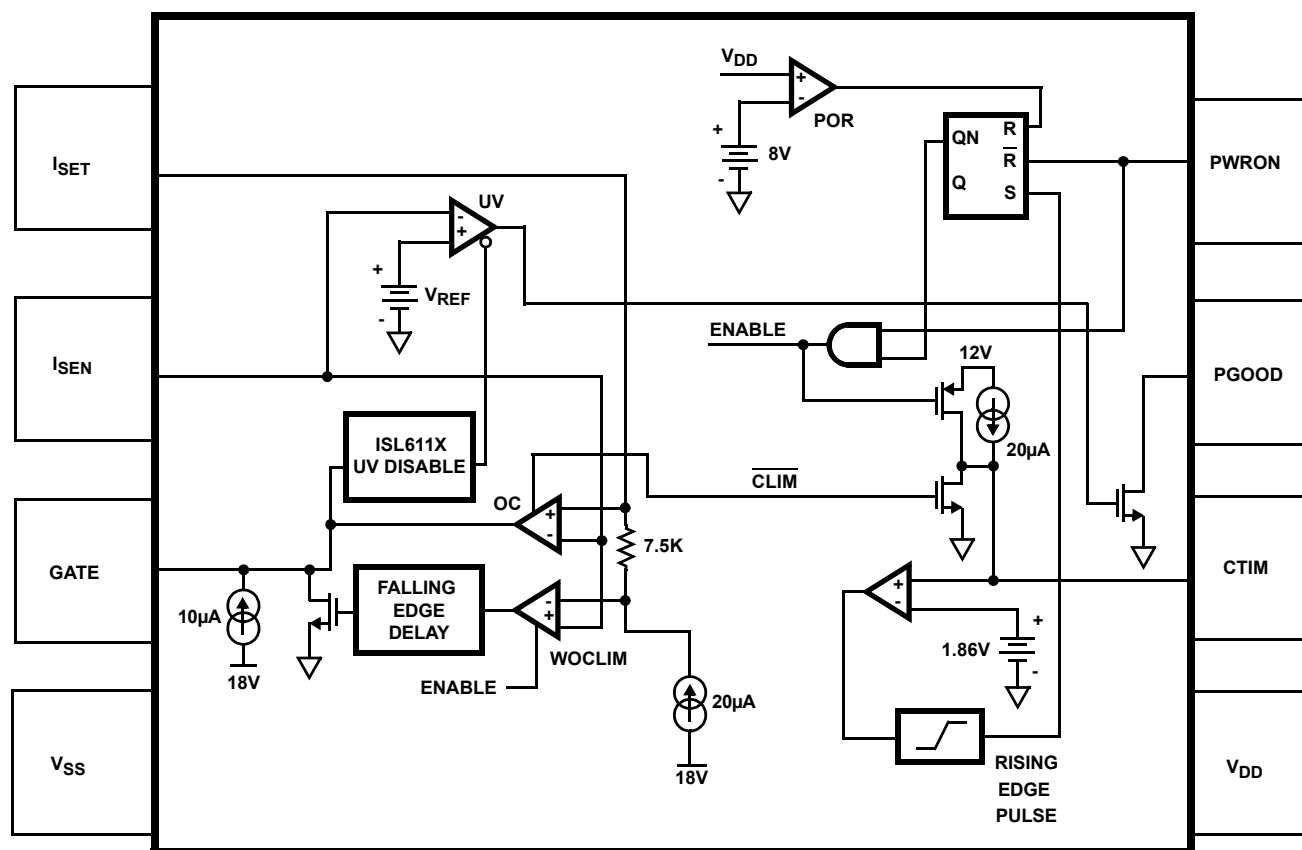

Pin Descriptions

PIN #	SYMBOL	FUNCTION	DESCRIPTION
1	ISET	Current Set	Connect to the low side of the current sense resistor through the current limiting set resistor. This pin functions as the current limit programming pin.
2	ISEN	Current Sense	Connect to the more positive end of sense resistor to measure the voltage drop across this resistor.
3	GATE	External FET Gate Drive Pin	Connect to the gate of the external N-Channel MOSFET. A capacitor from this node to ground sets the turn-on ramp. At turn-on this capacitor will be charged to $V_{DD} + 5V$ (ISL6115) and to V_{DD} (ISL6116, ISL6117, ISL6120) by a $10\mu A$ current source.
4	VSS	Chip Return	
5	V_{DD}	Chip Supply	12V chip supply. This can be either connected directly to the +12V rail supplying the switched load voltage or to a dedicated $V_{SS} + 12V$ supply.
6	CTIM	Current Limit Timing Capacitor	Connect a capacitor from this pin to ground. This capacitor determines the time delay between an overcurrent event and chip output shutdown (current limit time-out). The duration of current limit time-out is equal to $93k\Omega \times C_{TIM}$.
7	PGOOD	Power Good Indicator	Indicates that the voltage on the ISEN pin is satisfactory. PGOOD is driven by an open drain N-Channel MOSFET and is pulled low when the output voltage (V_{ISEN}) is less than the UV level for the particular IC.
8	PWRON	Power ON	PWRON is used to control and reset the chip. The chip is enabled when PWRON pin is driven high or is open. After a current limit time out, the chip is reset by a low level signal applied to this pin. This input has $20\mu A$ pull up capability.

ISL6115, ISL6116, ISL6117, ISL6120

Absolute Maximum Ratings $T_A = 25^\circ\text{C}$

V_{DD}	-0.3V to +16V
GATE	-0.3V to $V_{DD}+8\text{V}$
ISEN, PGOOD, PWRON, CTIM, ISET	-0.3V to $V_{DD} + 0.3\text{V}$
ESD Classification	5kV

Operating Conditions

V_{DD} Supply Voltage Range	+12V $\pm 15\%$
Temperature Range (T_A)	0°C to 85°C

Thermal Information

Thermal Resistance (Typical, Note 1)	θ_{JA} (°C/W)
SOIC Package	98
Maximum Junction Temperature (Plastic Package)	150°C
Maximum Storage Temperature Range	-65°C to 150°C
Maximum Lead Temperature (Soldering 10s)	300°C (SOIC - Lead Tips Only)

CAUTION: Stresses above those listed in "Absolute Maximum Ratings" may cause permanent damage to the device. This is a stress only rating and operation of the device at these or any other conditions above those indicated in the operational sections of this specification is not implied.

NOTES:

- θ_{JA} is measured with the component mounted on a high effective thermal conductivity test board in free air. (See Tech Brief, #TB379.1 for details.)
- All voltages are relative to GND, unless otherwise specified.

Electrical Specifications $V_{DD} = 12\text{V}$, $T_A = T_J = 0^\circ\text{C}$ to 85°C , Unless Otherwise Specified

PARAMETER	SYMBOL	TEST CONDITIONS	MIN	TYP	MAX	UNITS
CURRENT CONTROL						
ISET Current Source	I_{ISET_ft}		18.5	20	21.5	μA
ISET Current Source	I_{ISET_pt}	$T_J = 15^\circ\text{C}$ to 55°C	19	20	21	μA
Current Limit Amp Offset Voltage	V_{io_ft}	$V_{ISET} - V_{ISEN}$	-6	0	6	mV
Current Limit Amp Offset Voltage	V_{io_pt}	$V_{ISET} - V_{ISEN}$, $T_J = 15^\circ\text{C}$ to 55°C	-2	0	2	mV
GATE DRIVE						
GATE Response Time To Severe OC	pd_woc_amp	V_{GATE} to 10.8V	-	100	-	ns
GATE Response Time to Overcurrent	pd_oc_amp	V_{GATE} to 10.8V	-	600	-	ns
GATE Turn-On Current	I_{GATE}	V_{GATE} to = 6V	8.4	10	11.6	μA
GATE Pull Down Current	OC_GATE_I_4V	Overcurrent	45	75		mA
GATE Pull Down Current	WOC_GATE_I_4V	Severe Overcurrent	0.5	0.8	1.5	A
ISL6115 Undervoltage Threshold	12V _{UV_VTH}		9.2	9.6	10	V
ISL6115 GATE High Voltage	12VG	GATE Voltage	$V_{DD}+4.5\text{V}$	$V_{DD}+5\text{V}$	-	V
ISL6116 Undervoltage Threshold	5V _{UV_VTH}		4.0	4.35	4.5	V
ISL6117 Undervoltage Threshold	3V _{UV_VTH}		2.4	2.6	2.8	V
ISL6120 Undervoltage Threshold	2V _{UV_VTH}		1.8	1.85	1.9	V
ISL6116, 17, 20 GATE High Voltage	VG	GATE Voltage	$V_{DD}-1.5\text{V}$	V_{DD}	-	V
BIAS						
V_{DD} Supply Current	I_{VDD}		-	3	5	mA
V_{DD} POR Rising Threshold	$V_{DD_POR_L2H}$	VDD Low to High	7.8	8.4	9	V
V_{DD} POR Falling Threshold	$V_{DD_POR_H2L}$	VDD High to Low	7.5	8.1	8.7	V
V_{DD} POR Threshold Hysteresis	$V_{DD_POR_HYS}$	$V_{DD_POR_L2H} - V_{DD_POR_H2L}$	0.1	0.3	0.6	V
PWRON Pull-Up Voltage	PWRN_V	PWRON Pin Open	2.7	3.2	-	V
PWRON Rising Threshold	PWR_Vth		1.4	1.7	2.0	V
PWRON Hysteresis	PWR_hys		130	170	250	mV
PWRON Pull-Up Current	PWRN_I		9	17	25	μA

ISL6115, ISL6116, ISL6117, ISL6120

Electrical Specifications $V_{DD} = 12V$, $T_A = T_J = 0^\circ C$ to $85^\circ C$, Unless Otherwise Specified (Continued)

PARAMETER	SYMBOL	TEST CONDITIONS	MIN	TYP	MAX	UNITS
CURRENT REGULATION DURATION/POWER GOOD						
C_{TIM} Charging Current	C_{TIM_ichg0}	$V_{CTIM} = 0V$	16	20	23	μA
C_{TIM} Fault Pull-Up Current			16	20	23	mA
Current Limit Time-Out Threshold Voltage	C_{TIM_Vth}	CTIM Voltage	1.3	1.8	2.3	V
Power Good Pull Down Current	PG_l_{pd}	$V_{out} = 0.5V$		8		mA

Description and Operation

The members of this family are single power supply distribution controllers for generic hot swap applications across the +2.5V to +12V supply range. The ISL6115 is targeted for +12V switching applications whereas the ISL6116 is targeted for +5V, the ISL6117 for +3.3V and the ISL6120 for +2.5V applications. Each IC has a hardwired undervoltage (UV) threshold level approximately 17% lower than the stated voltages.

These ICs feature a highly accurate programmable overcurrent (OC) detecting comparator, programmable current regulation (CR) with programmable time delay to latch off, and programmable soft start turn-on ramp all set with a minimum of external passive components. The ICs also include severe OC protection that immediately shuts down the MOSFET switch should a rapid load current transient such as a near dead short cause the CR V_{th} to exceed the programmed level by 150mV. Additionally, the ICs have a UV indicator and an OC latch indicator. The functionality of the PGOOD feature is enabled once the IC is biased, monitoring and reporting any UV condition on the ISEN pin.

Upon initial power up, the IC can either isolate the voltage supply from the load by holding the external N-Channel MOSFET switch off or apply the supply rail voltage directly to the load for true hot swap capability. The PWRON pin must be pulled low for the device to isolate the power supply from the load by holding the external N-channel MOSFET off. With the PWRON pin held high or floating the IC will be in true hot swap mode. In both cases the IC turns on in a soft start mode protecting the supply rail from sudden in-rush current.

At turn-on, the external gate capacitor of the N-Channel MOSFET is charged with a 10 μA current source resulting in a programmable ramp (soft start turn-on). The internal ISL6115 charge pump supplies the gate drive for the 12V supply switch driving that gate to $\sim V_{DD} + 5V$, for the other three ICs the gate drive voltage is limited to the chip bias voltage, V_{DD} .

Load current passes through the external current sense resistor. When the voltage across the sense resistor exceeds the user programmed CR voltage threshold value, (see Table 1 for R_{ISET} programming resistor value and resulting nominal current regulation threshold voltage, V_{CR}) the controller

enters its current regulation mode. At this time, the time-out capacitor, on C_{TIM} pin is charged with a 20 μA current source and the controller enters the current limit time to latch-off period. The length of the current limit time to latch-off duration is set by the value of a single external capacitor (see Table 2 for C_{TIM} capacitor value and resulting nominal current limited time out to latch-off duration) placed from the C_{TIM} pin (pin 6) to ground. The programmed current level is held until either the OC event passes or the time out period expires. If the former is the case then the N-Channel MOSFET is fully enhanced and the C_{TIM} capacitor is discharged. Once C_{TIM} charges to 1.87V, signaling that the time out period has expired an internal latch is set whereby the FET gate is quickly pulled to 0V turning off the N-Channel MOSFET switch, isolating the faulty load.

TABLE 1.

R_{ISET} RESISTOR	NOMINAL OC V_{TH}
10k Ω	200mV
4.99k Ω	100mV
2.5k Ω	50mV
750 Ω	15mV

NOTE: Nominal $V_{th} = R_{ISET} \times 20\mu A$.

TABLE 2.

C_{TIM} CAPACITOR	NOMINAL CURRENT LIMITED PERIOD
0.022 μF	2ms
0.047 μF	4.4ms
0.1 μF	9.3ms

NOTE: Nominal time-out period = $C_{TIM} \times 93k\Omega$.

This IC responds to a severe overcurrent load (defined as a voltage across the sense resistor >150mV over the OC V_{th} set point) by immediately driving the N-Channel MOSFET gate to 0V in about 10 μs . The gate voltage is then slowly ramped up turning on the N-Channel MOSFET to the programmed current regulation level; this is the start of the time out period.

Upon a UV condition the PGOOD signal will pull low when tied high through a resistor to the logic or V_{DD} supply. This pin is a UV fault indicator. For an OC latch off indication, monitor C_{TIM} , pin 6. This pin will rise rapidly from 1.9V to V_{DD} once the time out period expires.

See Figures 12 to 16 for waveforms relevant to text.

The IC is reset after an OC latch-off condition by a low level on the PWRON pin and is turned on by the PWRON pin being driven high.

Application Considerations

During the soft start and the time-out delay duration with the IC in its current limit mode, the V_{GS} of the external N-Channel MOSFET is reduced driving the MOSFET switch into a (linear region) high $r_{DS(ON)}$ state. Strike a balance between the CR limit and the timing requirements to avoid periods when the external N-Channel MOSFETs may be damaged or destroyed due to excessive internal power dissipation. Refer to the **MOSFET SOA** information in the manufacturer's data sheet.

When driving particularly large capacitive loads a longer soft start time to prevent current regulation upon charging and a short CR time may offer the best application solution relative to reliability and FET MTF.

Physical layout of R_{SENSE} resistor is critical to avoid the possibility of false overcurrent occurrences. Ideally, trace routing between the R_{SENSE} resistors and the IC is as direct and as short as possible with zero current in the sense lines. (See Figure 1.)

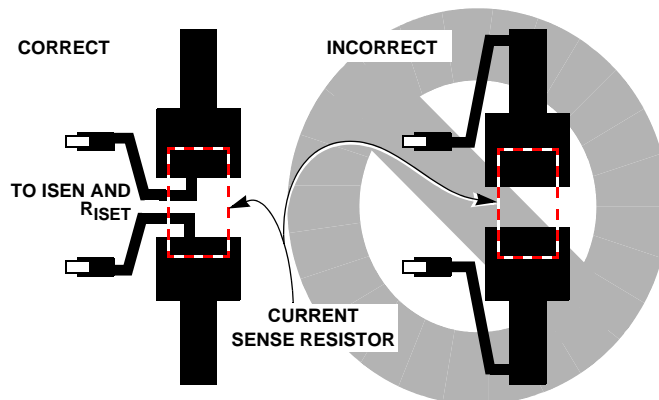

FIGURE 1. SENSE RESISTOR PCB LAYOUT

Using the ISL6116 as a -48V Low Side Hot Swap Power Controller

To supply the required V_{DD} , it is necessary to maintain the chip supply 10 to 16V above the -48V bus. This may be accomplished with a suitable regulator between the voltage rail and pin 5 (VDD). By using a regulator, the designer may ignore the bus voltage variations. However, a low-cost alternative is to use a Zener diode (See Figure 2 for typical 5A load control); this option is detailed below.

Note that in this configuration the PGOOD feature (pin 7) is not operational as the I_{SEN} pin voltage is always < UV threshold.

See Figures 17 to 20 for waveforms relevant to -48V and other high voltage applications.

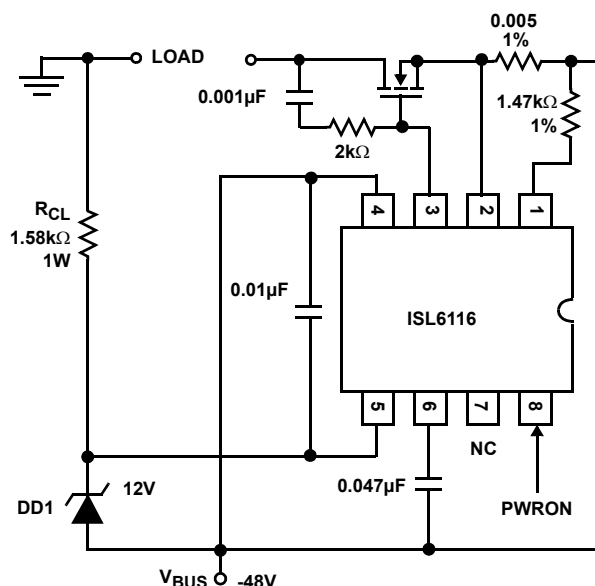

FIGURE 2.

Biasing the ISL6116

Table 3 gives typical component values for biasing the ISL6116 in a $\pm 48V$ application. The formulas and calculations deriving these values are also shown below.

TABLE 3. TYPICAL VALUES FOR A -48V HOT SWAP APPLICATION

SYMBOL	PARAMETER
R_{CL}	1.58k Ω , 1W
DD1	12V Zener Diode, 50mA Reverse Current

When using the ISL6116 to control -48V, a Zener diode may be used to provide the +12V bias to the chip. If a Zener is used then a current limit resistor should also be used. Several items must be taken into account when choosing values for the current limit resistor (R_{CL}) and Zener Diode (DD1):

- The variation of the V_{BUS} (in this case, -48V nominal)
- The chip supply current needs for all functional conditions
- The power rating of R_{CL} .
- The current rating of DD1

Formulas

1. Sizing R_{CL} :

$$R_{CL} = (V_{BUS,MIN} - 12) / I_{CHIP}$$
2. Power Rating of R_{CL} :

$$P_{RCL} = I_C (V_{BUS,MAX} - 12)$$
3. DD1 Current Rating:

$$I_{DD1} = (V_{BUS,MAX} - 12) / R_{CL}$$

ISL6115, ISL6116, ISL6117, ISL6120

Example

A typical -48V supply may vary from -36 to -72V. Therefore,

$$V_{BUS,MAX} = -72V$$

$$V_{BUS,MIN} = -36V$$

$$I_{CHIP} = 15mA \text{ (max)}$$

Sizing R_{CL} :

$$R_{CL} = (V_{BUS,MIN} - 12)/I_C$$

$$R_{CL} = (36 - 12)/0.015$$

$$R_{CL} = 1.6k\Omega \text{ [Typical Value} = 1.58k\Omega\text{]}$$

Power Rating of R_{CL} :

$$P_{RCL} = I_C(V_{BUS,MAX} - 12)$$

$$P_{RCL} = (0.015)(72 - 12)$$

$$P_{RCL} = 0.9W \text{ [Typical Value} = 1W\text{]}$$

DD1 Current Rating:

$$I_{DD1} = (V_{BUS,MAX} - 12)/R_{CL}$$

$$I_{DD1} = (72 - 12)/1.58k\Omega$$

$$I_{DD1} = 38mA \text{ [Typical Value} = 12V \text{ rating, } 50mA \text{ reverse current}\text{]}$$

Typical Performance Curves

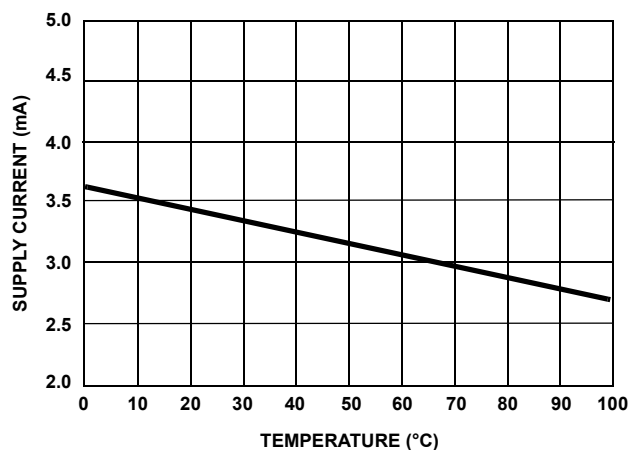

FIGURE 3. VDD BIAS CURRENT

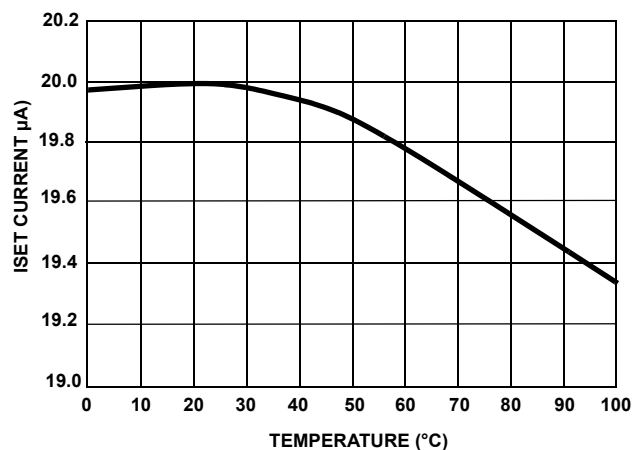

FIGURE 4. ISET SOURCE CURRENT

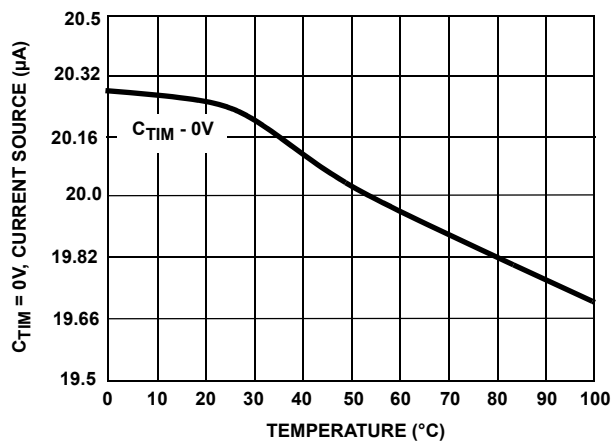

FIGURE 5. C_{TIM} CURRENT SOURCE

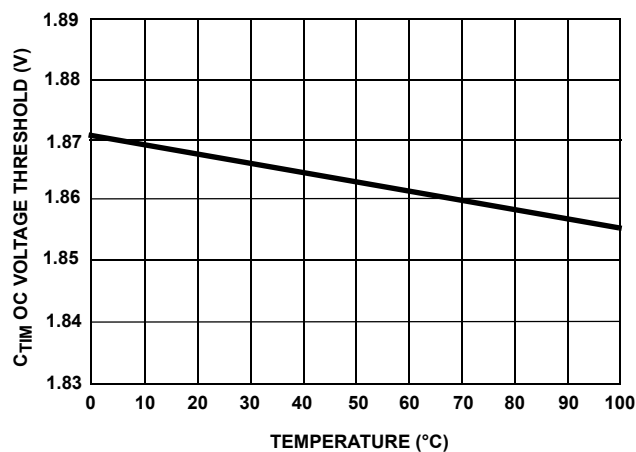

FIGURE 6. C_{TIM} OC VOLTAGE THRESHOLD

ISL6115, ISL6116, ISL6117, ISL6120

Typical Performance Curves (Continued)

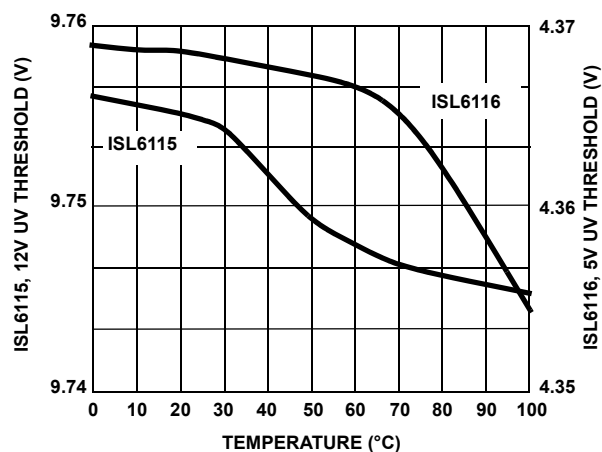

FIGURE 7. ISL6115/6116 UV THRESHOLD

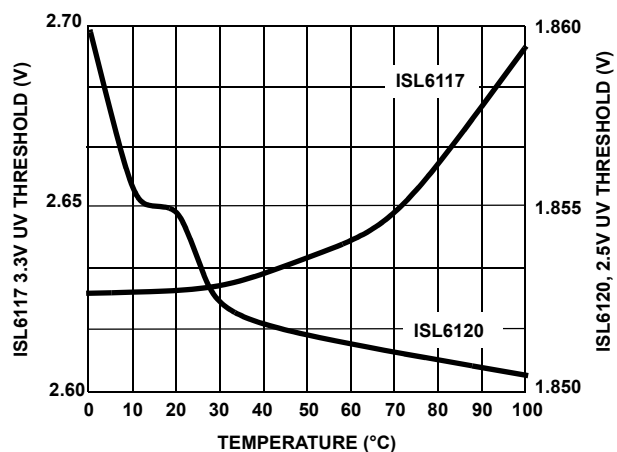

FIGURE 8. ISL6117/6120 UV THRESHOLD

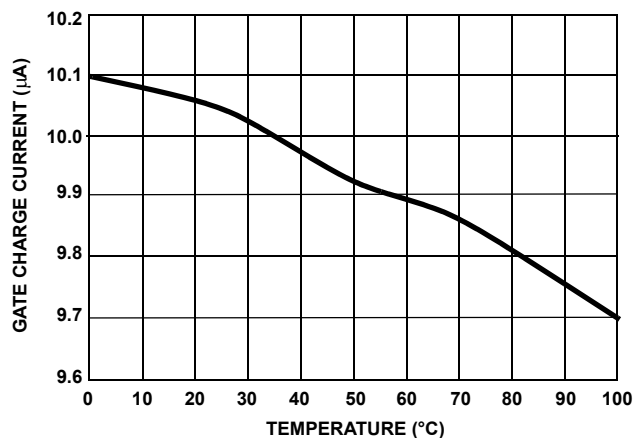

FIGURE 9. GATE CHARGE CURRENT

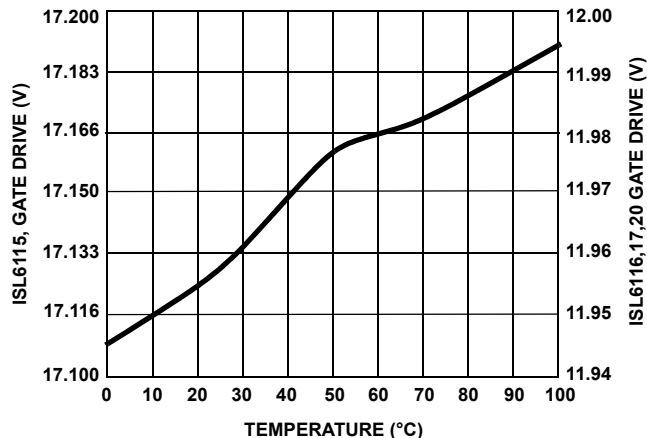

FIGURE 10. GATE DRIVE VOLTAGE, VDD = 12V

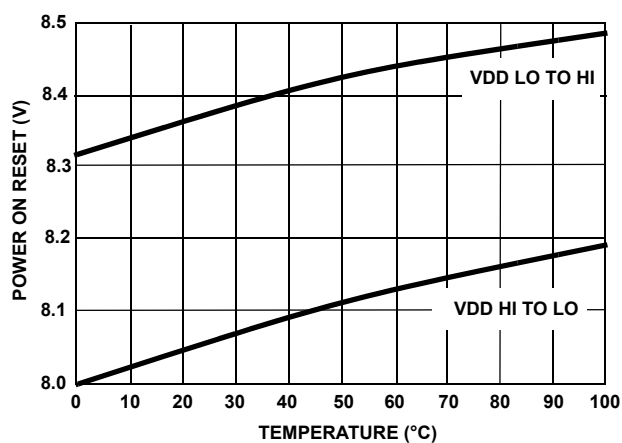

FIGURE 11. POWER ON RESET VOLTAGE THRESHOLD

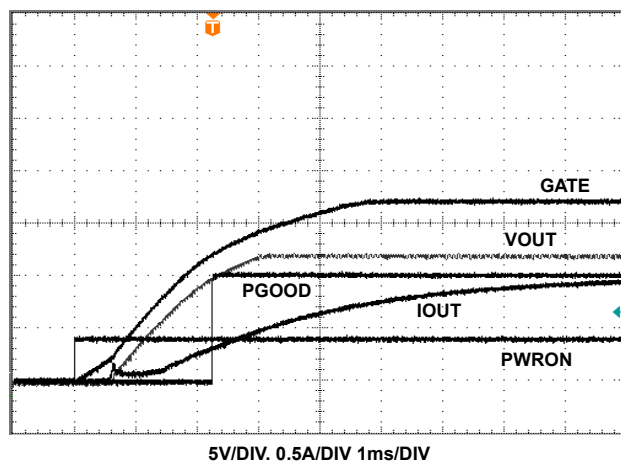

FIGURE 12. ISL6115 +12V TURN-ON

ISL6115, ISL6116, ISL6117, ISL6120

Typical Performance Curves (Continued)

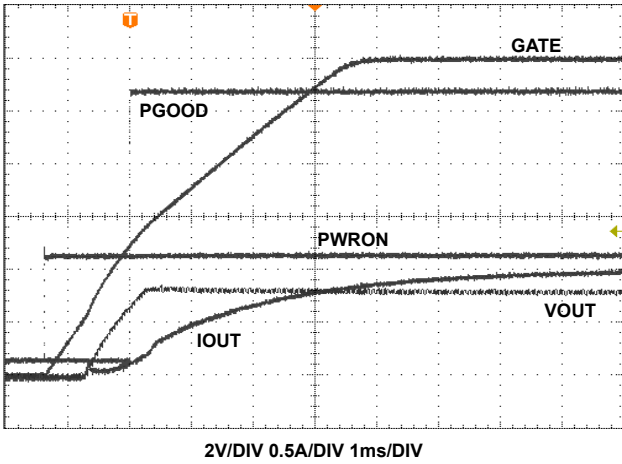

FIGURE 13. ISL6116 +5V TURN-ON

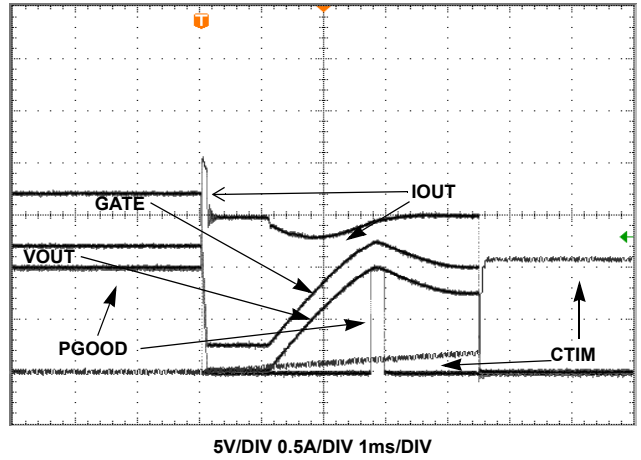

FIGURE 14. ISL6115 'LOW' OVERCURRENT RESPONSE

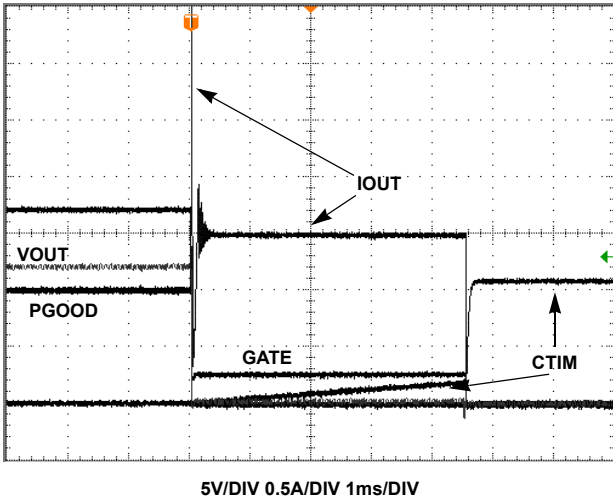

FIGURE 15. ISL6115 'HIGH' OVERCURRENT RESPONSE

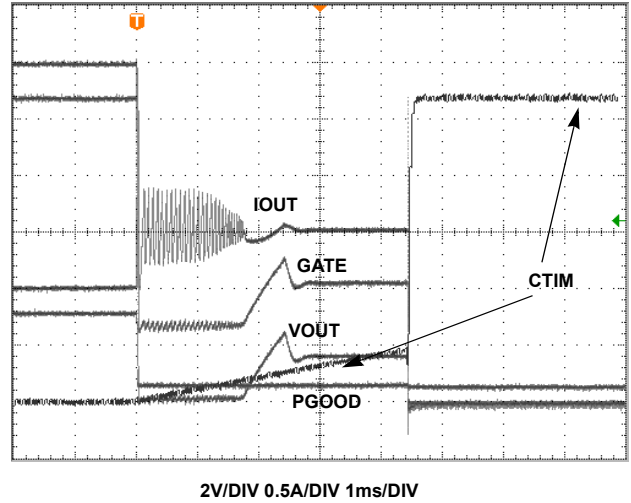

FIGURE 16. ISL6116 'HIGH' OVERCURRENT RESPONSE

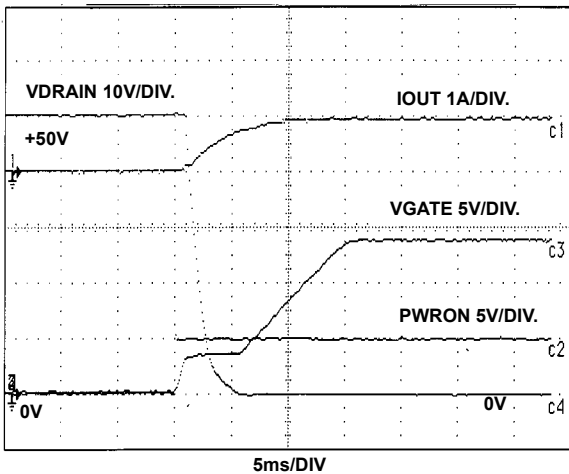

FIGURE 17. +50V LOW SIDE SWITCHING $C_{GATE} = 100\text{pF}$

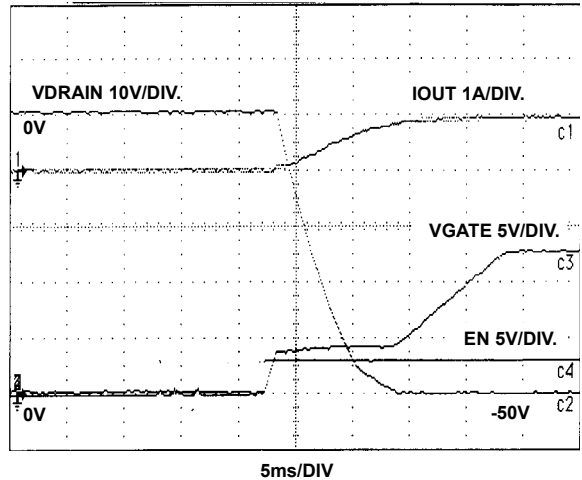

FIGURE 18. -50V LOW SIDE SWITCHING $C_{GATE} = 1000\text{pF}$

Typical Performance Curves (Continued)

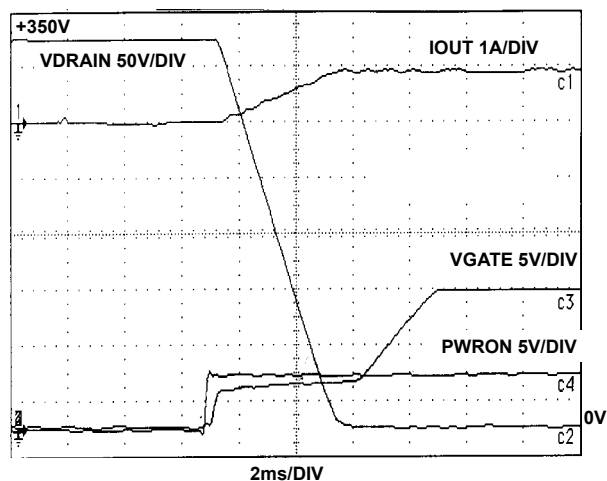

FIGURE 19. +350V LOW SIDE SWITCHING CGATE = 100pF

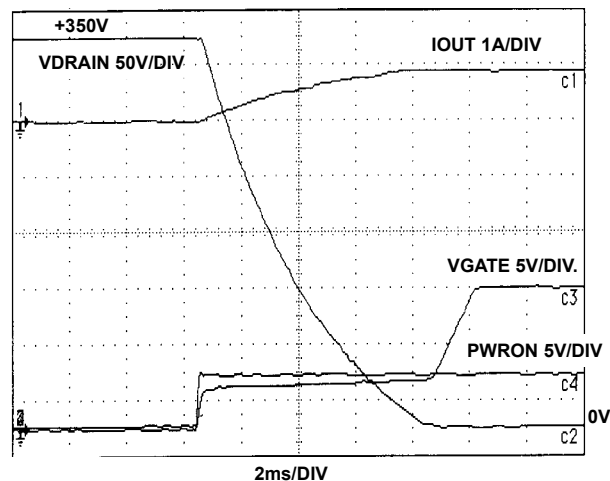

FIGURE 20. +350V LOW SIDE SWITCHING CGATE = 1000pF

ISL6115EVAL1 Board

The ISL6115EVAL1 is configured as a +12V high side switch controller with the CR level set at ~1.5A. (See Figure 21 for ISL6115EVAL1 schematic and Table 4. for BOM.) Bias and load connection points are provided along with test points for each IC pin.

With the chip to be biased from the +12V bus being switched, through B2, GND B5, the load connected between B3 and B4 and with jumper J1 installed the ISL6115 can be evaluated. PWRON pin pulls high enabling the ISL6115 if not driven low.

With $R2 = 750\Omega$ the CR V_{th} is set to 15mV and with the 10m Ω sense resistor the ISL6115EVAL1 has a nominal CR level of 1.5A. The 0.047 μ F delay time to latch-off capacitors results in a nominal 4.4ms before latch-off of outputs after an OC event.

Also included with the ISL6115EVAL1 board are one each of the ISL6116, ISL6117 and ISL6120 for evaluation.

ISL6116EVAL1 Board

The ISL6116EVAL1 is default configured as a negative voltage low side switch controller with a ~2.4A CR level. (See Figure 22 for ISL6116EVAL1 schematic and Table 4 for BOM and component description.) This basic configuration is capable of controlling both larger positive or negative potential voltages with minimal changes.

Bias and load connection points are provided in addition to test points, TP1-8 for each IC pin. The terminals, J1 and J4 are for the bus voltage and return, respectively, with the more negative potential being connected to J4. With the load between terminals J2 and J3 the board is now configured for evaluation. The device is enabled through LOGIN, TP9 with a TTL signal. ISL6116EVAL1 includes a level shifting circuit with an opto-coupling device for the PWRON input so that standard TTL logic can be translated to the -V reference for chip control.

When controlling a positive voltage, PWRON can be accessed at TP8.

The ISL6116EVAL1 is provided with a high voltage linear regulator for convenience to provide chip bias from $\pm 24V$ to $\pm 350V$. This can be removed and replaced with the zener & resistor bias scheme as discussed earlier. High voltage regulators and power discrete devices are no longer available from Intersil but can be purchased from other semiconductor manufacturers.

Reconfiguring the ISL6116EVAL1 board for a higher CR level can be done by changing the R_{SENSE} and R_{ISET} resistor values as the provided FET is 75A rated. If evaluation at >60V, an alternate FET must be chosen with an adequate BV_{DSS} .

ISL6115, ISL6116, ISL6117, ISL6120

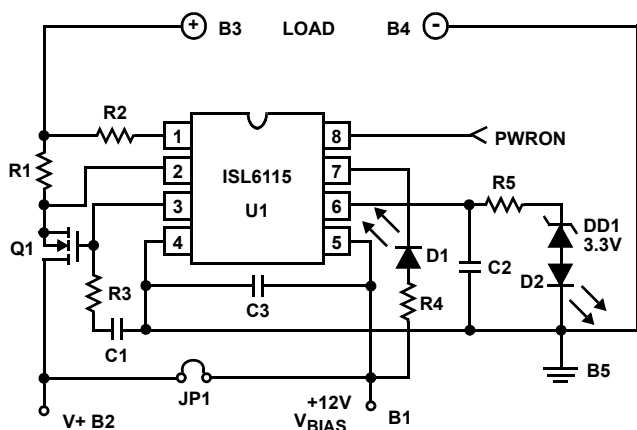

FIGURE 21. ISL6115EVAL1 HIGH SIDE SWITCH APPLICATION

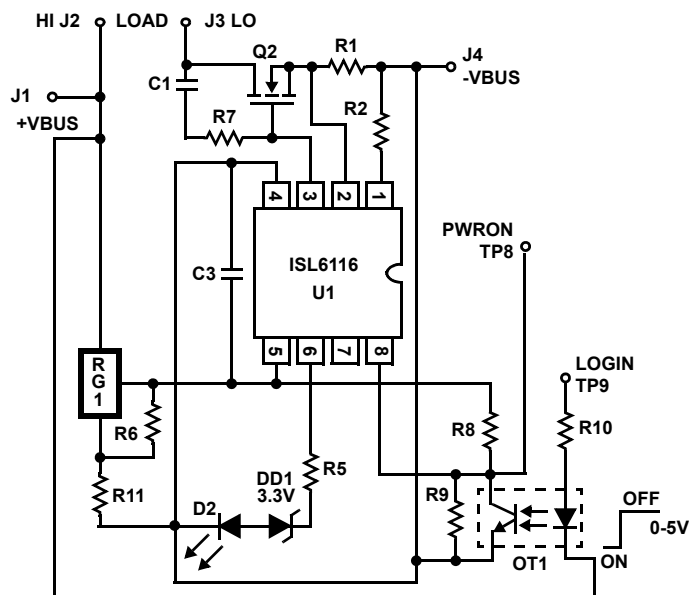

FIGURE 22. ISL6116EVAL1 NEGATIVE VOLTAGE LOW SIDE CONTROLLER

TABLE 4. BILL OF MATERIALS, ISL6115EVAL1, ISL6116EVAL1

COMPONENT DESIGNATOR	COMPONENT NAME	COMPONENT DESCRIPTION
Q1	HUF76132SK8	11.5mΩ, 30V, 11.5A Logic Level N-Channel Power MOSFET or equiv.
Q2	HUF7554S3S	10mΩ, 80V, 75A N-Channel Power MOSFET or equiv.
R1	Load Current Sense Resistor	Dale, WSL-2512 10mΩ 1W Metal Strip Resistor
High Side R2	Overcurrent Voltage Threshold Set Resistor	750Ω 805 Chip Resistor (V _{th} = 15mV)
Low side R2	Overcurrent Voltage Threshold Set Resistor	1.21kΩ 805 Chip Resistor (V _{th} = 24mV)
C2	Time Delay Set Capacitor	0.047μF 805 Chip Capacitor (4.5ms)
C1	Gate Timing Capacitor	0.001μF 805 Chip Capacitor (<2ms)
C3	IC Decoupling Capacitor	0.1μF 805 Chip Capacitor
R3	Gate Stability Resistor	20Ω 805 Chip Resistor
R7	Gate to Drain Resistor	2kΩ 805 Chip Resistor
JP1	Bias Voltage Selection Jumper	Install if switched rail voltage is = +12V ±15%. Remove and provide separate +12V bias voltage to U1 via TP5 if ISL6116, ISL6117, ISL6120 being evaluated.
R4, R5	LED Series Resistors	2.32kΩ 805 Chip Resistor
D1, D2	Fault Indicating LEDs	Low Current Red SMD LED
DD1	Fault Voltage Dropping Diode	3.3V Zener Diode, SOT-23 SMD 350mW
OT1	PWRON Level Shifting Opto-Coupler	PS2801-1 NEC
R8	Level Shifting Bias Resistor	2.32kΩ 805 Chip Resistor
R9	Level Shifting Bias Resistor	1.18kΩ 805 Chip Resistor
R10	Level Shifting Bias Resistor	200Ω 805 Chip Resistor
RG1	HIP5600IS	High Voltage Linear Regulator
R6	Linear Regulator RF1	1.78kΩ 805 Chip Resistor
R11	Linear Regulator RF2	15kΩ 805 Chip Resistor
TP1-TP8	Test Points for Device Pin Numbers 1-8	

ISL6115, ISL6116, ISL6117, ISL6120

Small Outline Plastic Packages (SOIC)

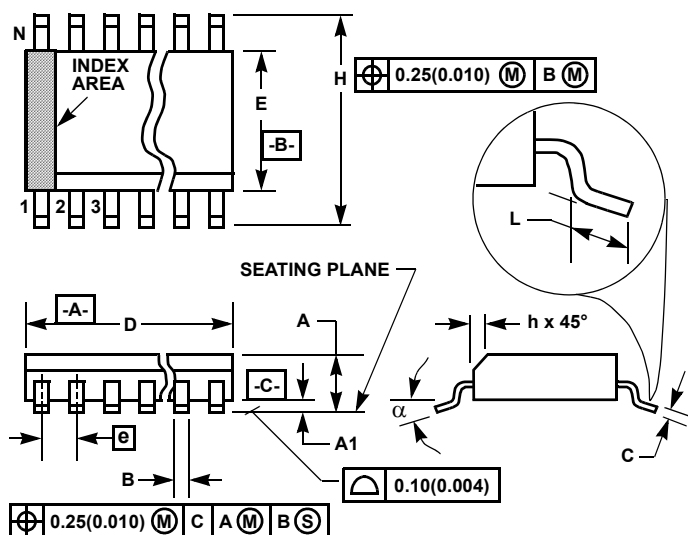

M8.15 (JEDEC MS-012-AA ISSUE C) 8 LEAD NARROW BODY SMALL OUTLINE PLASTIC PACKAGE

SYMBOL	INCHES		MILLIMETERS		NOTES
	MIN	MAX	MIN	MAX	
A	0.0532	0.0688	1.35	1.75	-
A1	0.0040	0.0098	0.10	0.25	-
B	0.013	0.020	0.33	0.51	9
C	0.0075	0.0098	0.19	0.25	-
D	0.1890	0.1968	4.80	5.00	3
E	0.1497	0.1574	3.80	4.00	4
e	0.050 BSC		1.27 BSC		-
H	0.2284	0.2440	5.80	6.20	-
h	0.0099	0.0196	0.25	0.50	5
L	0.016	0.050	0.40	1.27	6
N	8		8		7
α	0°	8°	0°	8°	-

NOTES:

1. Symbols are defined in the "MO Series Symbol List" in Section 2.2 of Publication Number 95.
2. Dimensioning and tolerancing per ANSI Y14.5M-1982.
3. Dimension "D" does not include mold flash, protrusions or gate burrs. Mold flash, protrusion and gate burrs shall not exceed 0.15mm (0.006 inch) per side.
4. Dimension "E" does not include interlead flash or protrusions. Interlead flash and protrusions shall not exceed 0.25mm (0.010 inch) per side.
5. The chamfer on the body is optional. If it is not present, a visual index feature must be located within the crosshatched area.
6. "L" is the length of terminal for soldering to a substrate.
7. "N" is the number of terminal positions.
8. Terminal numbers are shown for reference only.
9. The lead width "B", as measured 0.36mm (0.014 inch) or greater above the seating plane, shall not exceed a maximum value of 0.61mm (0.024 inch).
10. Controlling dimension: MILLIMETER. Converted inch dimensions are not necessarily exact.

Rev. 1 6/05

All Intersil U.S. products are manufactured, assembled and tested utilizing ISO9000 quality systems.
Intersil Corporation's quality certifications can be viewed at www.intersil.com/design/quality

Intersil products are sold by description only. Intersil Corporation reserves the right to make changes in circuit design, software and/or specifications at any time without notice. Accordingly, the reader is cautioned to verify that data sheets are current before placing orders. Information furnished by Intersil is believed to be accurate and reliable. However, no responsibility is assumed by Intersil or its subsidiaries for its use; nor for any infringements of patents or other rights of third parties which may result from its use. No license is granted by implication or otherwise under any patent or patent rights of Intersil or its subsidiaries.

For information regarding Intersil Corporation and its products, see www.intersil.com