



AME1085

3A Low Dropout Positive Voltage Regulator

General Description

The AME1085 is a 3A low-dropout positive voltage regulator. It is available in fixed and adjustable output voltage versions. Overcurrent and thermal protection are integrated onto the chip. Output current will limit as it reaches the pre-set current or temperature limit. At full rated output current the dropout voltage is 1.4V (max.). AME1085 series regulators provide excellent regulation over line, load and temperature variations.

Features

- Low dropout voltage 1.2V typically at 3A
- Adjustable or 3.3V fixed voltage
- Line regulation typically 0.015%
- Load regulation typically 0.05%
- Adjust pin (ADJ) current less than 90 μ A
- Overcurrent protection
- Thermal protection
- Available in TO-263, TO-252, TO-220

Applications

- High Efficiency Linear Regulators
- Post Regulators for Switching Supplies
- 5V to 3.3V Voltage Converter
- Battery Charger

Functional Block Diagram

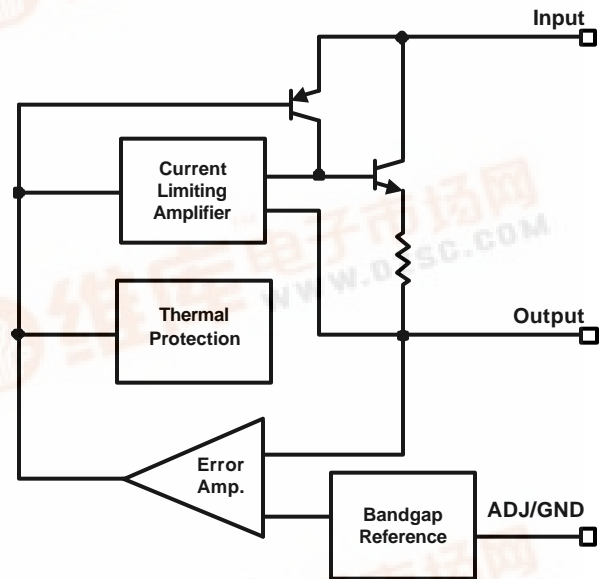

Typical Application

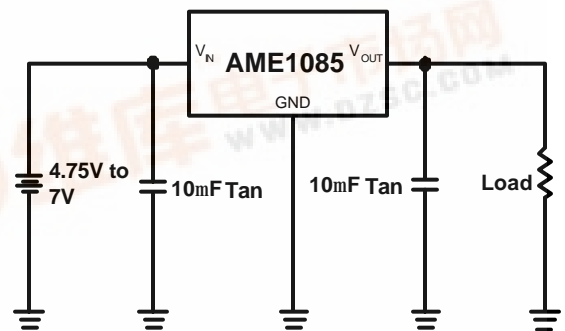



■ Pin Configuration

TO-263-3
Front View

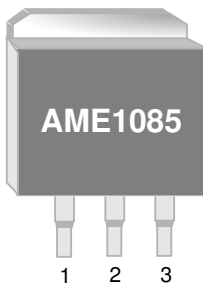

- AME1085**
1. ADJ/GND
 2. V_{OUT}
 3. V_{IN}

* Die Attached:
Soft Solder

TO-263-2
Front View

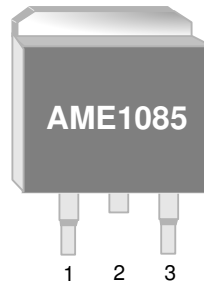

- AME1085**
1. ADJ/GND
 2. V_{OUT}
 3. V_{IN}

* Die Attached:
Soft Solder

TO-252-2
Front View

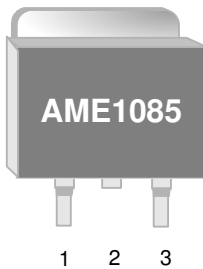

- AME1085**
1. ADJ/GND
 2. V_{OUT}
 3. V_{IN}

* Die Attached:
Soft Solder

TO-252-2
Front View

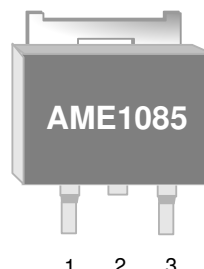

- AME1085**
1. ADJ/GND
 2. V_{OUT}
 3. V_{IN}

* Die Attached:
Soft Solder

TO-220
Front View

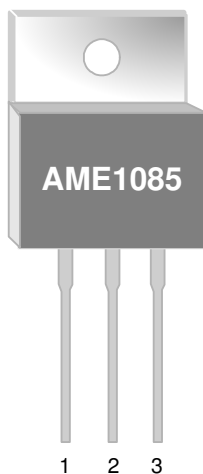

- AME1085**
1. ADJ/GND
 2. V_{OUT}
 3. V_{IN}

* Die Attached:
Soft Solder



AME, Inc.

AME1085

3A Low Dropout
Positive Voltage Regulator

■ Ordering Information

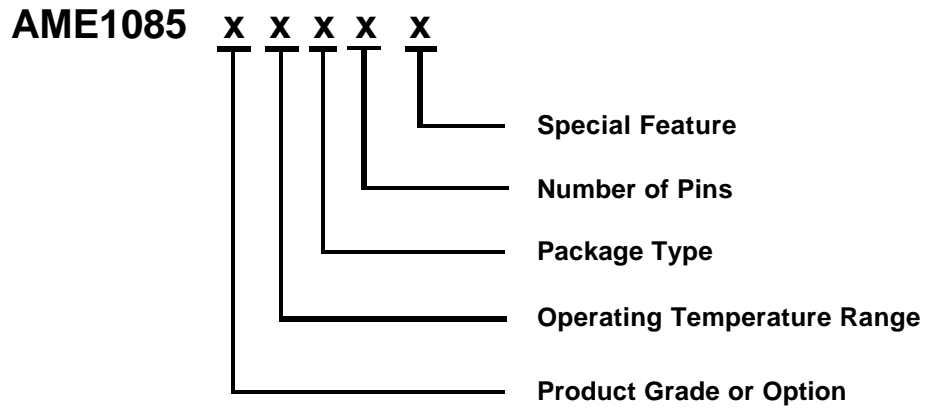

Product Grade or Option	Operating Temperature Range	Package Type	Number of Pins	Special Feature
A: ADJ D: 3.3V	C: 0°C to 70°C	B: TO-220 C: TO-252 (D PACK) D: TO-263	T: 3	Z: Lead Free



■ Ordering Information (contd.)

Part Number	Marking*	Output Voltage	Package	Operating Temp. Range
AME1085ACBT	AME1085 ACBT yyww	ADJ	TO-220	0°C to 70°C
AME1085ACBTZ	AME1085 ACBT yyww	ADJ	TO-220	0°C to 70°C
AME1085DCBT	AME1085 DCBT yyww	3.3	TO-220	0°C to 70°C
AME1085DCBTZ	AME1085 DCBT yyww	3.3	TO-220	0°C to 70°C
AME1085ACDT-3	AME1085 ACDT-3 yyww	ADJ	TO-263-3	0°C to 70°C
AME1085ACDT-3Z	AME1085 ACDT-3 yyww	ADJ	TO-263-3	0°C to 70°C
AME1085DCDT-3	AME1085 DCDT-3 yyww	3.3	TO-263-3	0°C to 70°C
AME1085DCDT-3Z	AME1085 DCDT-3 yyww	3.3	TO-263-3	0°C to 70°C
AME1085ACDT	AME1085 ACDT yyww	ADJ	TO-263-2	0°C to 70°C
AME1085ACDTZ	AME1085 ACDT yyww	ADJ	TO-263-2	0°C to 70°C
AME1085DCDT	AME1085 DCDT yyww	3.3	TO-263-2	0°C to 70°C
AME1085DCDTZ	AME1085 DCDT yyww	3.3	TO-263-2	0°C to 70°C

Note: yyww represents the date code

* A line on top of the first character represents lead free plating such as $\overline{\text{A}}$ ME1085

Please consult AME sales office or authorized Rep./Distributor for the availability of output voltage and package type.



AME, Inc.

AME1085

**3A Low Dropout
Positive Voltage Regulator**

■ Ordering Information (contd.)

Part Number	Marking*	Output Voltage	Package	Operating Temp. Range
AME1085AMCT**	AME1085 AMCT yyww	ADJ	TO-252-2	0°C to 70°C
AME1085AMCTZ**	AME1085 AMCT yyww	ADJ	TO-252-2	0°C to 70°C
AME1085MCT**	AME1085 MCT yyww	3.3	TO-252-2	0°C to 70°C
AME1085MCTZ**	AME1085 MCT yyww	3.3	TO-252-2	0°C to 70°C

** This differs from our standard part numbering scheme due to historical precedent,

1. For AME1085ACCT please order AME1085AMCT instead.
2. For AME1085ACCTZ please order AME1085AMCTZ instead.
3. For AME1085DCCT please order AME1085MCT instead.
4. For AME1085DCCTZ please order AME1085MCTZ instead.



■ Absolute Maximum Ratings

Parameter	Package	Die Attached	Symbol	Maximum	Unit
Thermal Resistance* (Junction to Case)	TO-220	Soft Solder	θ_{JC}	5	°C/W
	TO-263			4	
	TO-252			3	
Thermal Resistance (Junction to Ambient)	TO-220	Soft Solder	θ_{JA}	55	
	TO-263			85	
	TO-252			90	
Internal Power Dissipation	TO-220	Soft Solder	P_D	2100	mW
	TO-252			1200	
	TO-263			1600	
Input Voltage			V_{IN}	7	V
Operating Junction Temperature Range			T_J	0 to 125	°C
Storage Temperature Range			T_{STG}	- 65 to 150	
Lead Temperature (10 Sec)			T_{LEAD}	260	

* Measure θ_{JC} on backside center of tab.

Caution: Stress above the listed absolute maximum rating may cause permanent damage to the device.



AME, Inc.

3A Low Dropout

Positive Voltage Regulator

AME1085

■ Electrical Specifications

AME1085Axxx

Parameter	Symbol	Test Condition	Min	Typ	Max	Units	
Reference voltage (adjustable voltage)	V _{REF}	V _{IN} = 5V I _O = 10mA	T _J =25°C	1.238	1.250	1.262	V
			Over temp.	1.225		1.275	
Line regulation	Reg _{LINE}	V _{IN} = 2.75 - 7V I _O = 10mA	T _J =25°C	-	0.015	0.2	%
			Over temp.	-	0.035	0.2	
Load regulation	Reg _{LOAD}	V _{IN} = 5V I _O = 10mA - 3A	T _J =25°C	-	0.05	0.3	%
			Over temp.	-	0.2	0.4	
Dropout voltage ΔV _{OUT} , ΔV _{REF} = 1%	V _D	I _O = 10mA - 3A	T _J =25°C	-	1.2	1.4	V
			Over temp.	-	1.3	-	
Current limit	I _S	V _{IN} = 2.75 - 7V, Over temp.	3.0	-	-	A	
Temperature Coefficient	T _C	V _{IN} = 2.75 - 7V, I _O = 10mA - 3A	-	0.005	-	%/°C	
Adjust pin current	I _{ADJ}	V _{IN} = 2.75~7V, I _O = 10mA~3A	T _J = 25°C	-	55	-	μA
			Over Temp.	-	-	120	
Adjust pin current change	ΔI _{ADJ}	V _{IN} = 2.75~7V, I _O = 10mA~3A, Over Temp.	-	0.2	5	μA	
Temperature stability	T _S	V _{IN} = 5V, I _O = 500mA, Over temp.	-	0.5	-	%	
Minimum load current	I _O	V _{IN} = 5V	10	-	-	mA	
RMS output noise	V _N	T _J =25°C	-	0.003	-	%V _O	
Ripple rejection ratio	R _A	V _{IN} = 5V, I _O = 3A, Over temp.	-	72	-	dB	

AME1085Dxxx

Parameter	Symbol	Test Condition	Min	Typ	Max	Units	
Output voltage (fixed voltage)	V _O	V _{IN} = 5V I _O = 0A	T _J =25°C	3.267	3.300	3.333	V
			Over temp.	3.234		3.366	
Line regulation	Reg _{LINE}	V _{IN} =4.5 - 7V I _O = 0A	T _J =25°C	-	0.015	0.2	%
			Over temp.	-	0.035	0.2	
Load regulation	Reg _{LOAD}	V _{IN} = 5V I _O = 0A - 3A	T _J =25°C	-	0.05	0.3	%
			Over temp.	-	0.2	0.4	
Dropout voltage ΔV _{OUT} , ΔV _{REF} = 1%	V _D	V _{IN} = 4.5 - 7V I _O = 0A - 3A	T _J =25°C	-	1.2	1.4	V
			Over temp.	-	1.3	-	
Current limit	I _S	V _{IN} = 4.5 - 7V, Over temp.	3.0	-	-	A	
Quiescent current (fixed model)	I _Q	V _{IN} = 5V, I _O =0A - 3A, Over temp.	-	12	13	mA	
Temperature Coefficient	T _C	V _{IN} = 4.5 - 7V, I _O = 0A - 3A	-	0.005	-	%/°C	
Temperature stability	T _S	V _{IN} = 5V, I _O = 500mA, Over temp.	-	0.5	-	%	
RMS output noise	V _N	T _J =25°C	-	0.003	-	%V _O	
Ripple rejection ratio	R _A	V _{IN} = 5V, I _O = 3A, Over temp.	60	72	-	dB	

■ Application Description

1. Output voltage adjustment

Like most regulators, the AME1085 regulates the output by comparing the output voltage to an internally generated reference voltage. On the adjustable version, the V_{REF} is available externally as 1.25V between V_{OUT} and ADJ. The voltage ratio formed by R1 and R2 should be set to conduct 10mA (minimum output load). The output voltage is given by the following equation:

$$V_{OUT} = V_{REF} \left(1 + \frac{R2}{R1} \right) + I_{ADJ} \times R2$$

On fixed versions of AME1085, the voltage divider is provided internally.

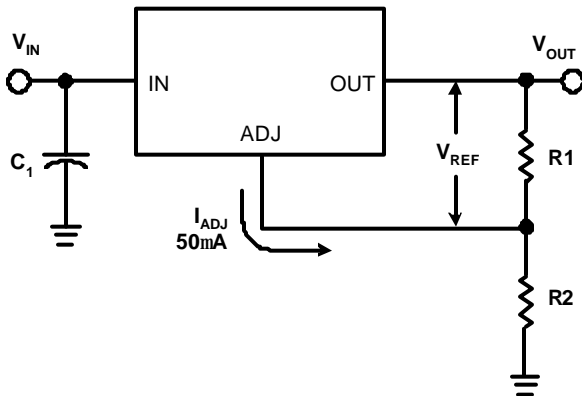

$$V_{OUT} = V_{REF} \left(1 + \frac{R2}{R1} \right) + I_{ADJ} \times R2$$

2. Thermal protection

AME1085 has thermal protection which limits junction temperature to 150°C. However, device functionality is only guaranteed to a maximum junction temperature of +125°C.

The power dissipation and junction temperature for AME1085 in TO-220 package are given by

$$P_D = (V_{IN} - V_{OUT}) \times I_{OUT}$$

$$T_{JUNCTION} = T_{AMBIENT} + (P_D \times \theta_{JA})$$

Note: $T_{JUNCTION}$ must not exceed 125°C

3. Current limit protection

AME1085 is protected against overload conditions. Current protection is triggered at typical 4.5A.

4. Stability and load regulation

AME1085 requires a capacitor from V_{OUT} to GND to provide compensation feedback to the internal gain stage. This is to ensure stability at the output terminal. Typically, a 10µF tantalum or 50µF aluminum electrolytic is sufficient.

(Note: It is important that the ESR for this capacitor does not exceed 0.5W.)

The output capacitor does not have a theoretical upper limit and increasing its value will increase stability. $C_{OUT} = 100\mu\text{F}$ or more is typical for high current regulator design.

For the adjustable version, the best load regulation is accomplished when the top of the resistor divider (R1) is connected directly to the output pin of the AME1085. When so connected, R_p is not multiplied by the divider ratio. For fixed output versions, the top of R1 is internally connected to the output and ground pin can be connected to low side of the load.

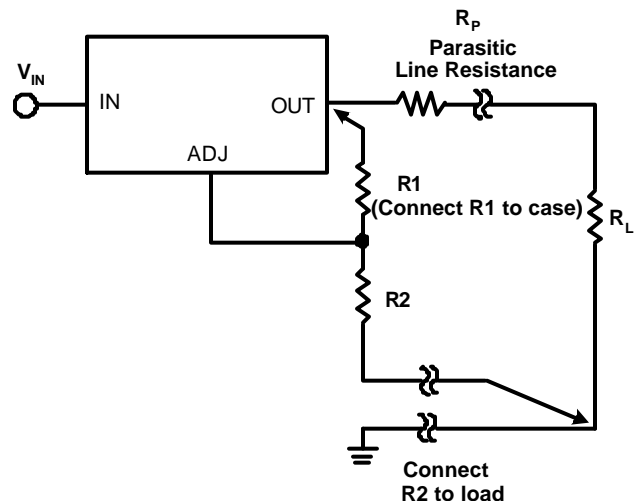



AME, Inc.

AME1085

**3A Low Dropout
Positive Voltage Regulator**

5. Thermal consideration

The AME1085 series contain thermal limiting circuitry designed to protect itself for over-temperature conditions. Even for normal load conditions, maximum junction temperature ratings must not be exceeded. As mentioned in the thermal protection section, we need to consider all sources of thermal resistance between junction and ambient. It includes junction-to-case, case-to-heat-sink interface and heat sink thermal resistance itself.

Junction-to-case thermal resistance is specified from the IC junction to the bottom of the case directly below the die. Proper mounting is required to ensure the best possible thermal flow from this area of the package to the heat sink. The case of all devices in this series is electrically connected to the output. Therefore, if the case of the device must be electrically isolated, a thermally conductive spacer is recommended.



■ Advanced Applications

Adjustable Output Voltage

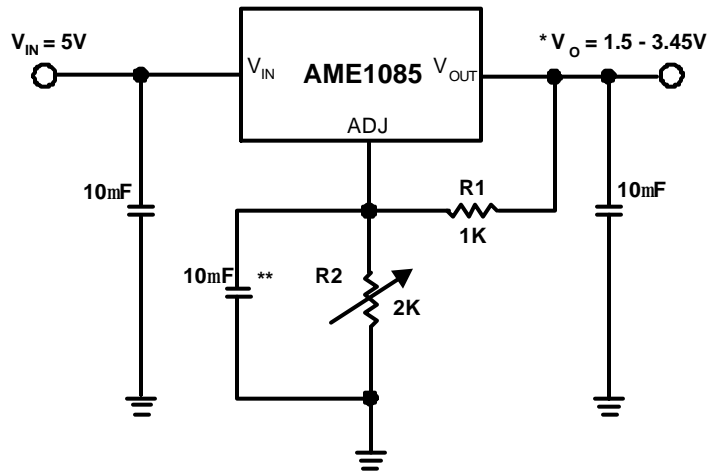

Note: $* V_{OUT} = V_{REF} \left(1 + \frac{R2}{R1} \right) + I_{ADJ} \times R2$

** Optional for improved ripple rejection

Paralleling Regulators

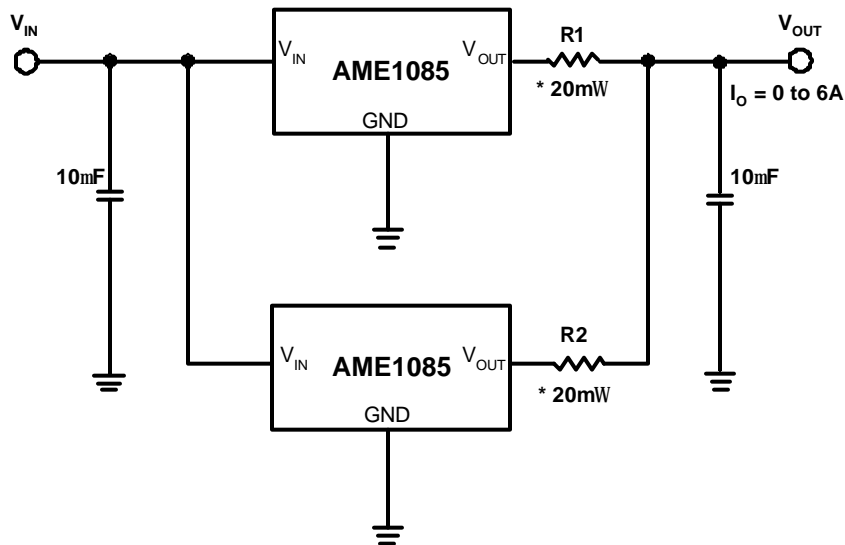

Note: * 20mΩ is ballast resistance
 The inter - connection of #18 wire could act as ballast resistance



■ Advanced Applications (contd.)

Regulator with Reference

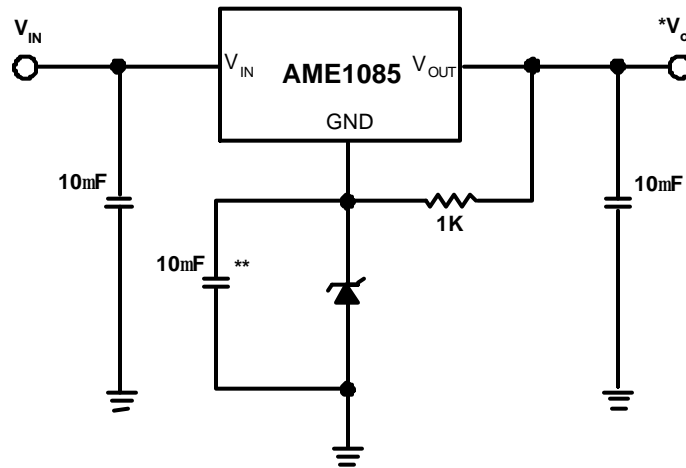

Note: * $V_o = V_{REF} + V_z$ (V_z : breakdown voltage of Zener diode)
** Optional for improved ripple rejection

Regulator with Reverse Diode Protection

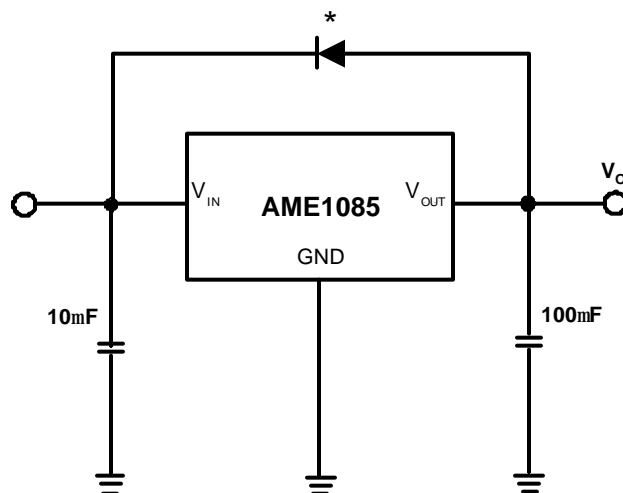



External Resistor Divider Table for Customized Voltage

R1 (Ohm)	100	102	105	107	110	113	115	118	121	124
Vout	$R2(\text{Ohm})=(V_{\text{out}}-1.25)*R1/(1.25+50u*R1)$									
1.25	0.000	0.000	0.000	0.000	0.000	0.000	0.000	0.000	0.000	0.000
1.30	3.984	4.063	4.182	4.262	4.381	4.500	4.579	4.698	4.817	4.936
1.35	7.968	8.127	8.365	8.524	8.761	8.999	9.158	9.396	9.633	9.871
1.40	11.95	12.19	12.55	12.79	13.14	13.50	13.74	14.09	14.45	14.81
1.45	15.94	16.25	16.73	17.05	17.52	18.00	18.32	18.79	19.27	19.74
1.50	19.92	20.32	20.91	21.31	21.90	22.50	22.89	23.49	24.08	24.68
1.55	23.90	24.38	25.09	25.57	26.28	27.00	27.47	28.19	28.90	29.61
1.60	27.89	28.44	29.28	29.83	30.67	31.50	32.05	32.88	33.72	34.55
1.65	31.87	32.51	33.46	34.09	35.05	36.00	36.63	37.58	38.53	39.48
1.70	35.86	36.57	37.64	38.36	39.43	40.50	41.21	42.28	43.35	44.42
1.75	39.84	40.63	41.82	42.62	43.81	45.00	45.79	46.98	48.17	49.36
1.80	43.82	44.70	46.01	46.88	48.19	49.50	50.37	51.68	52.98	54.29
1.85	47.81	48.76	50.19	51.14	52.57	54.00	54.95	56.37	57.80	59.23
1.90	51.79	52.82	54.37	55.40	56.95	58.50	59.53	61.07	62.62	64.16
1.95	55.78	56.89	58.55	59.66	61.33	63.00	64.11	65.77	67.43	69.10
2.00	59.76	60.95	62.74	63.93	65.71	67.49	68.68	70.47	72.25	74.03
2.05	63.75	65.01	66.92	68.19	70.09	71.99	73.26	75.17	77.07	78.97
2.10	67.73	69.08	71.10	72.45	74.47	76.49	77.84	79.86	81.88	83.90
2.15	71.71	73.14	75.28	76.71	78.85	80.99	82.42	84.56	86.70	88.84
2.20	75.70	77.21	79.47	80.97	83.23	85.49	87.00	89.26	91.52	93.77
2.25	79.68	81.27	83.65	85.24	87.61	89.99	91.58	93.96	96.33	98.71
2.30	83.67	85.33	87.83	89.50	92.00	94.49	96.16	98.65	101.2	103.6
2.35	87.65	89.40	92.01	93.76	96.38	98.99	100.7	103.4	106.0	108.6
2.40	91.63	93.46	96.20	98.02	100.8	103.5	105.3	108.1	110.8	113.5
2.45	95.62	97.52	100.4	102.3	105.1	108.0	109.9	112.7	115.6	118.5
2.50	99.60	101.6	104.6	106.5	109.5	112.5	114.5	117.4	120.4	123.4
2.55	103.6	105.6	108.7	110.8	113.9	117.0	119.1	122.1	125.2	128.3
2.60	107.6	109.7	112.9	115.1	118.3	121.5	123.6	126.8	130.1	133.3
2.65	111.6	113.8	117.1	119.3	122.7	126.0	128.2	131.5	134.9	138.2
2.70	115.5	117.8	121.3	123.6	127.0	130.5	132.8	136.2	139.7	143.1
2.75	119.5	121.9	125.5	127.9	131.4	135.0	137.4	140.9	144.5	148.1
2.80	123.5	126.0	129.7	132.1	135.8	139.5	141.9	145.6	149.3	153.0
2.85	127.5	130.0	133.8	136.4	140.2	144.0	146.5	150.3	154.1	157.9
2.90	131.5	134.1	138.0	140.6	144.6	148.5	151.1	155.0	159.0	162.9
2.95	135.5	138.2	142.2	144.9	148.9	153.0	155.7	159.7	163.8	167.8
3.00	139.4	142.2	146.4	149.2	153.3	157.5	160.3	164.4	168.6	172.7
3.05	143.4	146.3	150.6	153.4	157.7	162.0	164.8	169.1	173.4	177.7
3.10	147.4	150.3	154.8	157.7	162.1	166.5	169.4	173.8	178.2	182.6



AME1085

External Resistor Divider Table for Customized Voltage (contd.)

R1 (Ohm)	100	102	105	107	110	113	115	118	121	124
Vout	R2(Ohm)=(Vout-1.25)*R1/(1.25+50u*R1)									
3.15	151.4	154.4	158.9	161.9	166.5	171.0	174.0	178.5	183.0	187.5
3.20	155.4	158.5	163.1	166.2	170.8	175.5	178.6	183.2	187.9	192.5
3.25	159.4	162.5	167.3	170.5	175.2	180.0	183.2	187.9	192.7	197.4
3.30	163.3	166.6	171.5	174.7	179.6	184.5	187.7	192.6	197.5	202.4
3.35	167.3	170.7	175.7	179.0	184.0	189.0	192.3	197.3	202.3	207.3
3.40	171.3	174.7	179.8	183.3	188.4	193.5	196.9	202.0	207.1	212.2
3.45	175.3	178.8	184.0	187.5	192.8	198.0	201.5	206.7	211.9	217.2
3.50	179.3	182.9	188.2	191.8	197.1	202.5	206.1	211.4	216.8	222.1
3.55	183.3	186.9	192.4	196.0	201.5	207.0	210.6	216.1	221.6	227.0
3.60	187.3	191.0	196.6	200.3	205.9	211.5	215.2	220.8	226.4	232.0
3.65	191.2	195.0	200.8	204.6	210.3	216.0	219.8	225.5	231.2	236.9
3.70	195.2	199.1	204.9	208.8	214.7	220.5	224.4	230.2	236.0	241.8
3.75	199.2	203.2	209.1	213.1	219.0	225.0	228.9	234.9	240.8	246.8
3.80	203.2	207.2	213.3	217.3	223.4	229.5	233.5	239.6	245.7	251.7
3.85	207.2	211.3	217.5	221.6	227.8	234.0	238.1	244.3	250.5	256.6
3.90	211.2	215.4	221.7	225.9	232.2	238.5	242.7	249.0	255.3	261.6
3.95	215.1	219.4	225.9	230.1	236.6	243.0	247.3	253.7	260.1	266.5
4.00	219.1	223.5	230.0	234.4	240.9	247.5	251.8	258.4	264.9	271.5
4.05	223.1	227.6	234.2	238.7	245.3	252.0	256.4	263.1	269.7	276.4
4.10	227.1	231.6	238.4	242.9	249.7	256.5	261.0	267.8	274.6	281.3
4.15	231.1	235.7	242.6	247.2	254.1	261.0	265.6	272.5	279.4	286.3
4.20	235.1	239.7	246.8	251.4	258.5	265.5	270.2	277.2	284.2	291.2
4.25	239.0	243.8	250.9	255.7	262.8	270.0	274.7	281.9	289.0	296.1
4.30	243.0	247.9	255.1	260.0	267.2	274.5	279.3	286.6	293.8	301.1
4.35	247.0	251.9	259.3	264.2	271.6	279.0	283.9	291.3	298.6	306.0
4.40	251.0	256.0	263.5	268.5	276.0	283.5	288.5	296.0	303.5	310.9
4.45	255.0	260.1	267.7	272.8	280.4	288.0	293.1	300.7	308.3	315.9
4.50	259.0	264.1	271.9	277.0	284.7	292.5	297.6	305.4	313.1	320.8
4.55	262.9	268.2	276.0	281.3	289.1	297.0	302.2	310.1	317.9	325.7
4.60	266.9	272.2	280.2	285.5	293.5	301.5	306.8	314.8	322.7	330.7
4.65	270.9	276.3	284.4	289.8	297.9	306.0	311.4	319.5	327.5	335.6
4.70	274.9	280.4	288.6	294.1	302.3	310.5	315.9	324.2	332.4	340.6
4.75	278.9	284.4	292.8	298.3	306.7	315.0	320.5	328.8	337.2	345.5
4.80	282.9	288.5	297.0	302.6	311.0	319.5	325.1	333.5	342.0	350.4
4.85	286.9	292.6	301.1	306.8	315.4	324.0	329.7	338.2	346.8	355.4
4.90	290.8	296.6	305.3	311.1	319.8	328.5	334.3	342.9	351.6	360.3
4.95	294.8	300.7	309.5	315.4	324.2	333.0	338.8	347.6	356.4	365.2
5.00	298.8	304.8	313.7	319.6	328.6	337.5	343.4	352.3	361.3	370.2



■ Tape and Reel Dimension

TO-252

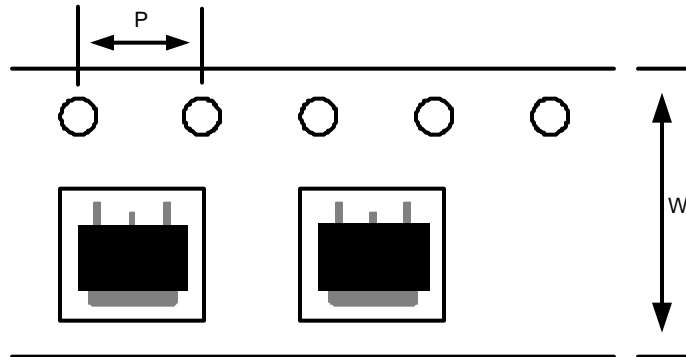

Carrier Tape, Number of Components Per Reel and Reel Size

Package	Carrier Width (W)	Pitch (P)	Part Per Full Reel	Reel Size
TO-252	16.0±0.1 mm	4.0±0.1 mm	2500pcs	330±1 mm

TO-263

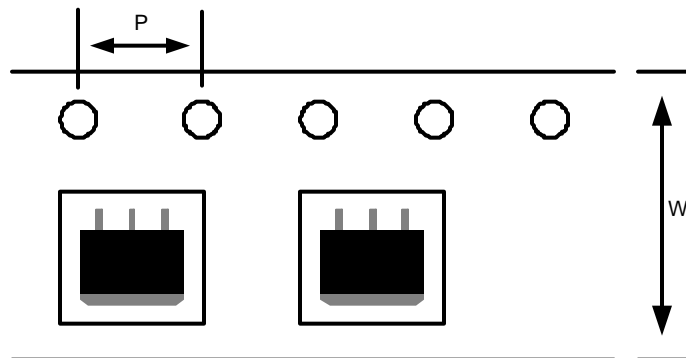

Carrier Tape, Number of Components Per Reel and Reel Size

Package	Carrier Width (W)	Pitch (P)	Part Per Full Reel	Reel Size
TO-263-3L	24.0±0.1 mm	4.0±0.1 mm	800pcs	330±1 mm
TO-263-2L	24.0±0.1 mm	4.0±0.1 mm	800pcs	330±1 mm

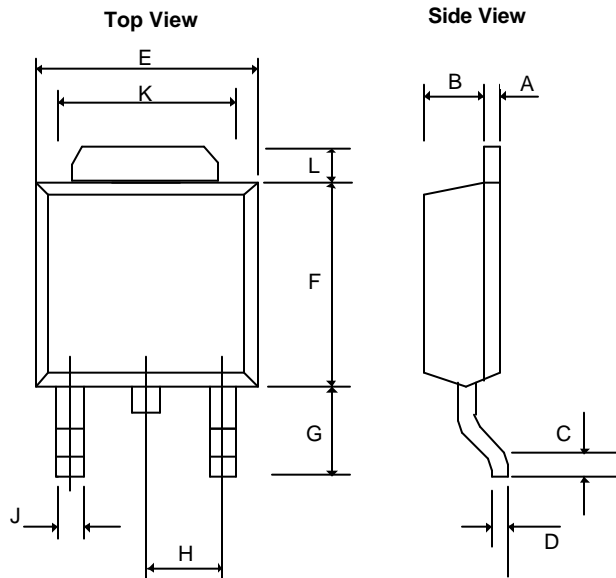
■ Package Dimension
TO-252(DPAK)-EIAJ

SYMBOLS	MILLIMETERS		INCHES	
	MIN	MAX	MIN	MAX
A	0.43	0.58	0.0169	0.0230
B	1.60	1.95	0.0630	0.0768
C	0.51	1.78	0.0200	0.0701
D	0.43	0.60	0.0169	0.0236
E	6.35	6.80	0.2500	0.2677
F	5.36	7.20	0.2110	0.2835
G	2.20	3.00	0.0866	0.1181
H	-	* 2.30	-	*0.0906
J	-	0.97	-	0.0380
K	5.20	5.50	0.2047	0.2165
L	1.40REF		0.055REF	

*: **Typical Value**

Notes:

1. Controlling dimension: Millimeters.
2. Maximum lead thickness includes lead finish thickness Minimum lead thickness is the minimum thickness of base material.

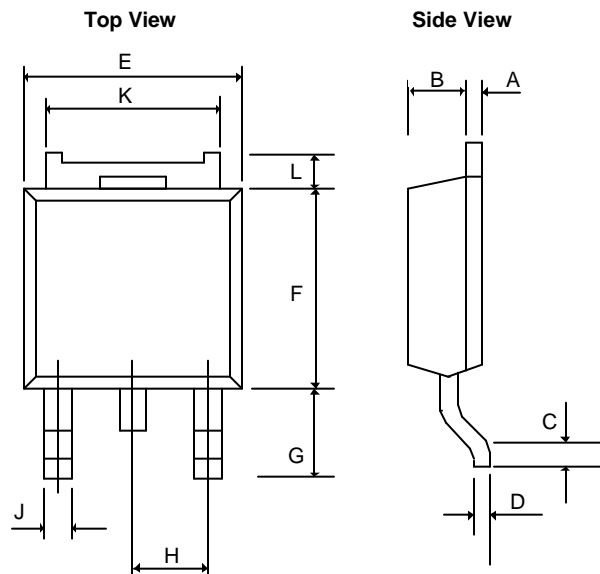
TO-252(DPAK)-JEDC

SYMBOLS	MILLIMETERS		INCHES	
	MIN	MAX	MIN	MAX
A	0.49	0.51	0.0192	0.0201
B	1.79	1.81	0.0704	0.0713
C	0.55	-	0.0216	-
D	0.49	0.51	0.0192	0.0201
E	6.58	6.62	0.2590	0.2606
F	6.08	6.12	0.2393	0.2409
G	2.68	2.72	0.1055	0.1071
H	* 2.30REF		* 0.0906REF	
J	0.96		0.0377	
K	5.31	5.37	0.2090	0.2114
L	0.68	0.72	0.0267	0.0283

*: **Typical Value**

Notes:

1. Controlling dimension: Millimeters.
2. Maximum lead thickness includes lead finish thickness Minimum lead thickness is the minimum thickness of base material.



■ Package Dimension

TO-263-2(D²PAK)

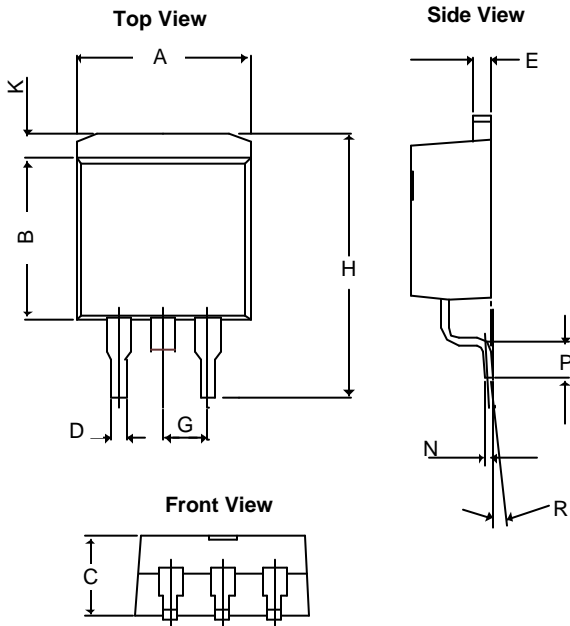

SYMBOLS	MILLIMETERS		INCHES	
	MIN	MAX	MIN	MAX
A	9.65	10.42	0.380	0.410
B	8.28	9.66	0.326	0.380
C	4.06	4.83	0.160	0.190
D	0.50	1.36	0.020	0.054
E	1.14	1.45	0.045	0.057
G	*2.54		*0.100	
H	14.60	15.60	0.5748	0.61417
K	0.99	2.93	0.03898	0.11535
N	0.381REF		0.015REF	
P	2.28	2.80	0.08976	0.11024
R	0°	8°	0°	8°

*: Typical Value

Notes:

1. Controlling dimension: Millimeters.
2. Maximum lead thickness includes lead finish thickness Minimum lead thickness is the minimum thickness of base material.

TO-263-3(D²PAK)

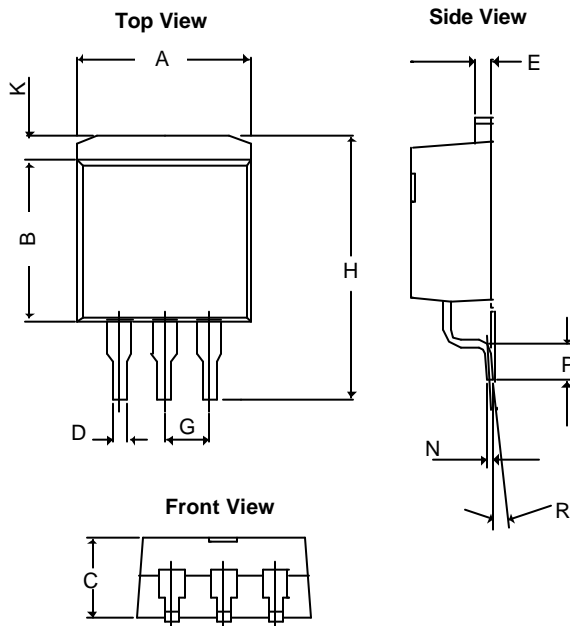

SYMBOLS	MILLIMETERS		INCHES	
	MIN	MAX	MIN	MAX
A	9.65	10.668	0.380	0.420
B	8.28	9.66	0.326	0.380
C	4.06	4.83	0.160	0.190
D	0.50	1.36	0.020	0.054
E	1.14	1.45	0.045	0.057
G	*2.54		*0.100	
H	14.60	15.875	0.5748	0.625
K	0.99	2.93	0.03898	0.11535
N	0.381REF		0.015REF	
P	2.28	2.80	0.08976	0.11024
R	0°	8°	0°	8°

*: Typical Value

Notes:

1. Controlling dimension: Millimeters.
2. Maximum lead thickness includes lead finish thickness Minimum lead thickness is the minimum thickness of base material.



AME, Inc.

AME1085

3A Low Dropout
Positive Voltage Regulator

■ Package Dimension

TO-220

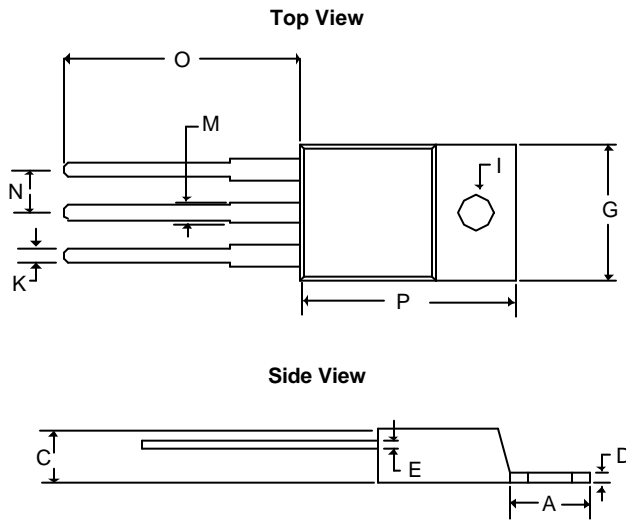

SYMBOLS	MILLIMETERS		INCHES	
	MIN	MAX	MIN	MAX
A	5.58	7.49	0.2197	0.2949
C	2.03	4.83	0.0800	0.1902
D	0.50	1.40	0.0197	0.0550
E	0.30	1.15	0.0118	0.0453
G	9.65	10.67	0.3799	0.4200
I	3.53	4.09	0.1390	0.1610
K	0.50	1.15	0.0197	0.0453
M	1.14	1.78	0.0449	0.0700
N	2.28	2.80	0.0898	0.1102
O	12.70	14.74	0.5000	0.5803
P	14.22	16.51	0.5600	0.6500



www.ame.com.tw
E-Mail: sales@ame.com.tw

Life Support Policy:

These products of AME, Inc. are not authorized for use as critical components in life-support devices or systems, without the express written approval of the president of AME, Inc.

AME, Inc. reserves the right to make changes in the circuitry and specifications of its devices and advises its customers to obtain the latest version of relevant information.

©AME, Inc. , September 2005

Document: 1013-DS1085-M

Corporate Headquarter
AME, Inc.

2F, 302 Rui-Guang Road, Nei-Hu District
Taipei 114, Taiwan.
Tel: 886 2 2627-8687
Fax: 886 2 2659-2989

U.S.A.(Subsidiary)
Analog Microelectronics, Inc.

3100 De La Cruz Blvd., Suite 201
Santa Clara, CA. 95054-2046
Tel : (408) 988-2388
Fax: (408) 988-2489



中发网 WWW.ZFA.CN

全球最大的PDF中文下载站



中发网
www.zfa.cn

PDF 资料下载尽在中发网