

December 1992

CMOS Presettable Up/Down Counter

Features

- High-Voltage Type (20V Rating)
- Medium Speed Operation: 8MHz (Typ.) at CL = 50pF and VDD - VSS = 10V
- Multi-Package Parallel Clocking for Synchronous High Speed Output Response or Ripple Clocking for Slow Clock Input Rise and Fall Times
- "Preset Enable" and Individual "Jam" Inputs Provided
- Binary or Decade Up/Down Counting
- BCD Outputs in Decade Mode
- 100% Tested for Maximum Quiescent Current at 20V
- 5V, 10V and 15V Parametric Ratings
- Standardized Symmetrical Output Characteristics
- Maximum Input Current of 1µA at 18V Over Full Package-Temperature Range; 100nA at 18V and +25°C
- Noise Margin (Over Full Package Temperature Range):
 - 1V at VDD = 5V
 - 2V at VDD = 10V
 - 2.5V at VDD = 15V
- Meets All Requirements of JEDEC Tentative Standards No. 13B, "Standard Specifications for Description of "B" Series CMOS Device's

Applications

- Programmable Binary and Decade Counting/Frequency Synthesizers-BCD Output
- Analog to Digital and Digital to Analog Conversion
- Up/Down Binary Counting
- Difference Counting
- Magnitude and Sign Generation
- Up/Down Decade Counting

Description

CD4029BMS consists of a four-stage binary or BCD-decade up/down counter with provisions for look-ahead carry in both counting modes. The inputs consist of a single CLOCK, $\overline{\text{CARRY-IN}}$ (CLOCK ENABLE), BINARY/DECADE, UP/DOWN, PRESET ENABLE, and four individual JAM signals. Q1, Q2, Q3, Q4 and a CARRY OUT signal are provided as outputs.

A high PRESET ENABLE signal allows information on the JAM INPUTS to preset the counter to any state asynchronously with the clock. A low on each JAM line, when the PRESET-ENABLE signal is high, resets the counter to its zero count. The counter is advanced one count at the positive transition of the clock when the $\overline{\text{CARRY-IN}}$ and PRE-SET ENABLE signals are low. Advancement is inhibited when the $\overline{\text{CARRY-IN}}$ or PRESET ENABLE signals are high. The CARRY-OUT signal is normally high and goes low when the counter reaches its maximum count in the UP mode or the minimum count in the DOWN mode provided the $\overline{\text{CARRY-IN}}$ signal is low. The $\overline{\text{CARRY-IN}}$ signal in the low state can thus be considered a CLOCK ENABLE. The CARRY-IN terminal must be connected to VSS when not in use.

Binary counting is accomplished when the BINARY/DECADE input is high; the counter counts in the decade mode when the BINARY/DECADE input is low. The counter counts up when the UP/DOWN input is high, and down when the UP/DOWN input is low. Multiple packages can be connected in either a parallel-clocking or a ripple-clocking arrangement as shown in Figure 17.

Parallel clocking provides synchronous control and hence faster response from all counting outputs. Ripple-clocking allows for longer clock input rise and fall times.

The CD4029BMS is supplied in these 16-lead outline packages:

- Braze Seal DIP H4X
- Frit Seal DIP H1F
- Ceramic Flatpack H6W

Pinout

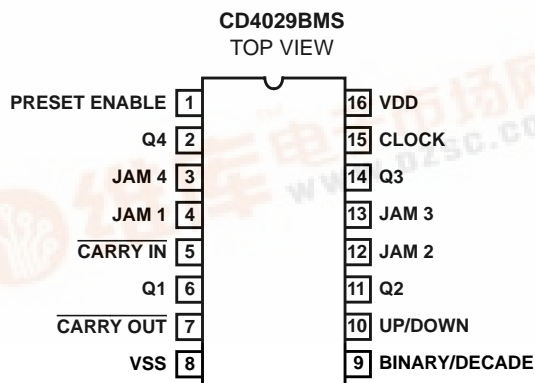

Functional Diagram

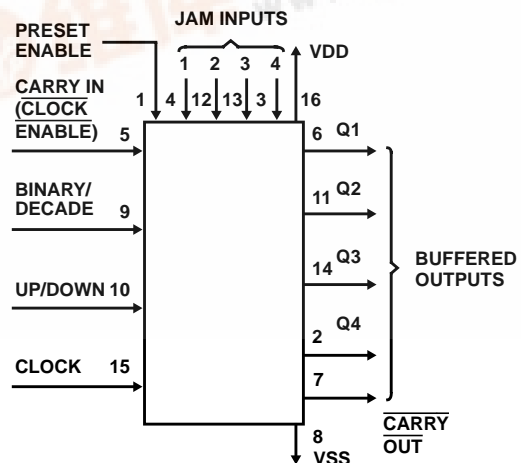

Specifications CD4029BMS

Absolute Maximum Ratings

DC Supply Voltage Range, (VDD) -0.5V to +20V
 (Voltage Referenced to VSS Terminals)
 Input Voltage Range, All Inputs -0.5V to VDD +0.5V
 DC Input Current, Any One Input ±10mA
 Operating Temperature Range -55°C to +125°C
 Package Types D, F, K, H
 Storage Temperature Range (TSTG) -65°C to +150°C
 Lead Temperature (During Soldering) +265°C
 At Distance 1/16 ± 1/32 Inch (1.59mm ± 0.79mm) from case for
 10s Maximum

Reliability Information

Thermal Resistance θ_{ja} θ_{jc}
 Ceramic DIP and FRIT Package 80°C/W 20°C/W
 Flatpack Package 70°C/W 20°C/W
 Maximum Package Power Dissipation (PD) at +125°C
 For TA = -55°C to +100°C (Package Type D, F, K) 500mW
 For TA = +100°C to +125°C (Package Type D, F, K) Derate
 Linearity at 12mW/°C to 200mW
 Device Dissipation per Output Transistor 100mW
 For TA = Full Package Temperature Range (All Package Types)
 Junction Temperature +175°C

TABLE 1. DC ELECTRICAL PERFORMANCE CHARACTERISTICS

PARAMETER	SYMBOL	CONDITIONS (NOTE 1)		GROUP A SUBGROUPS	TEMPERATURE	LIMITS		UNITS
						MIN	MAX	
Supply Current	IDD	VDD = 20V, VIN = VDD or GND		1	+25°C	-	10	μA
				2	+125°C	-	1000	μA
		VDD = 18V, VIN = VDD or GND		3	-55°C	-	10	μA
Input Leakage Current	IIL	VIN = VDD or GND	VDD = 20	1	+25°C	-100	-	nA
				2	+125°C	-1000	-	nA
		VDD = 18V		3	-55°C	-100	-	nA
Input Leakage Current	IIH	VIN = VDD or GND	VDD = 20	1	+25°C	-	100	nA
				2	+125°C	-	1000	nA
		VDD = 18V		3	-55°C	-	100	nA
Output Voltage	VOL15	VDD = 15V, No Load		1, 2, 3	+25°C, +125°C, -55°C	-	50	mV
Output Voltage	VOH15	VDD = 15V, No Load (Note 3)		1, 2, 3	+25°C, +125°C, -55°C	14.95	-	V
Output Current (Sink)	IOL5	VDD = 5V, VOUT = 0.4V		1	+25°C	0.53	-	mA
Output Current (Sink)	IOL10	VDD = 10V, VOUT = 0.5V		1	+25°C	1.4	-	mA
Output Current (Sink)	IOL15	VDD = 15V, VOUT = 1.5V		1	+25°C	3.5	-	mA
Output Current (Source)	IOH5A	VDD = 5V, VOUT = 4.6V		1	+25°C	-	-0.53	mA
Output Current (Source)	IOH5B	VDD = 5V, VOUT = 2.5V		1	+25°C	-	-1.8	mA
Output Current (Source)	IOH10	VDD = 10V, VOUT = 9.5V		1	+25°C	-	-1.4	mA
Output Current (Source)	IOH15	VDD = 15V, VOUT = 13.5V		1	+25°C	-	-3.5	mA
N Threshold Voltage	VNTH	VDD = 10V, ISS = -10μA		1	+25°C	-2.8	-0.7	V
P Threshold Voltage	VPTH	VSS = 0V, IDD = 10μA		1	+25°C	0.7	2.8	V
Functional	F	VDD = 2.8V, VIN = VDD or GND		7	+25°C	VOH > VDD/2	VOL < VDD/2	V
		VDD = 20V, VIN = VDD or GND		7	+25°C			
		VDD = 18V, VIN = VDD or GND		8A	+125°C			
		VDD = 3V, VIN = VDD or GND		8B	-55°C			
Input Voltage Low (Note 2)	VIL	VDD = 5V, VOH > 4.5V, VOL < 0.5V		1, 2, 3	+25°C, +125°C, -55°C	-	1.5	V
Input Voltage High (Note 2)	VIH	VDD = 5V, VOH > 4.5V, VOL < 0.5V		1, 2, 3	+25°C, +125°C, -55°C	3.5	-	V
Input Voltage Low (Note 2)	VIL	VDD = 15V, VOH > 13.5V, VOL < 1.5V		1, 2, 3	+25°C, +125°C, -55°C	-	4	V
Input Voltage High (Note 2)	VIH	VDD = 15V, VOH > 13.5V, VOL < 1.5V		1, 2, 3	+25°C, +125°C, -55°C	11	-	V

NOTES: 1. All voltages referenced to device GND, 100% testing being implemented. 3. For accuracy, voltage is measured differentially to VDD. Limit is 0.050V max.
 2. Go/No Go test with limits applied to inputs.

Specifications CD4029BMS

TABLE 2. AC ELECTRICAL PERFORMANCE CHARACTERISTICS

PARAMETER	SYMBOL	CONDITIONS (NOTE 1, 2)	GROUP A SUBGROUPS	TEMPERATURE	LIMITS		UNITS
					MIN	MAX	
Propagation Delay Clock To Q Output	TPHL1 TPLH1	VDD = 5V, VIN = VDD or GND	9	+25°C	-	500	ns
			10, 11	+125°C, -55°C	-	675	ns
Propagation Delay Clock To Carry Out	TPHL2 TPLH2	VDD = 5V, VIN = VDD or GND	9	+25°C	-	560	ns
			10, 11	+125°C, -55°C	-	756	ns
Propagation Delay Preset Enable To Q	TPHL3 TPLH3	VDD = 5V, VIN = VDD or GND	9	+25°C	-	470	ns
			10, 11	+125°C, -55°C	-	635	ns
Propagation Delay Preset Enable To Carry- Out	TPHL4 TPLH4	VDD = 5V, VIN = VDD or GND	9	+25°C	-	640	ns
			10, 11	+125°C, -55°C	-	864	ns
Propagation Delay Carry-In To Carry-Out	TPHL5 TPLH5	VDD = 5V, VIN = VDD or GND	9	+25°C	-	340	ns
			10, 11	+125°C, -55°C	-	459	ns
Transition Time Q Output	TTHL TTLH	VDD = 5V, VIN = VDD or GND	9	+25°C	-	200	ns
			10, 11	+125°C, -55°C	-	270	ns
Maximum Clock Input Frequency	FCL	VDD = 5V, VIN = VDD or GND	9	+25°C	2	-	MHz
			10, 11	+125°C, -55°C	1.48	-	MHz

NOTES:

1. VDD = 5V, CL = 50pF, RL = 200K
2. -55°C and +125°C limits guaranteed, 100% testing being implemented.

TABLE 3. ELECTRICAL PERFORMANCE CHARACTERISTICS

PARAMETER	SYMBOL	CONDITIONS	NOTES	TEMPERATURE	LIMITS		UNITS
					MIN	MAX	
Supply Current	IDD	VDD = 5V, VIN = VDD or GND	1, 2	-55°C, +25°C	-	5	μA
				+125°C	-	150	μA
		VDD = 10V, VIN = VDD or GND	1, 2	-55°C, +25°C	-	10	μA
				+125°C	-	300	μA
		VDD = 15V, VIN = VDD or GND	1, 2	-55°C, +25°C	-	10	μA
				+125°C	-	600	μA
Output Voltage	VOL	VDD = 5V, No Load	1, 2	+25°C, +125°C, -55°C	-	50	mV
Output Voltage	VOL	VDD = 10V, No Load	1, 2	+25°C, +125°C, -55°C	-	50	mV
Output Voltage	VOH	VDD = 5V, No Load	1, 2	+25°C, +125°C, -55°C	4.95	-	V
Output Voltage	VOH	VDD = 10V, No Load	1, 2	+25°C, +125°C, -55°C	9.95	-	V
Output Current (Sink)	IOL5	VDD = 5V, VOUT = 0.4V	1, 2	+125°C	0.36	-	mA
				-55°C	0.64	-	mA
Output Current (Sink)	IOL10	VDD = 10V, VOUT = 0.5V	1, 2	+125°C	0.9	-	mA
				-55°C	1.6	-	mA
Output Current (Sink)	IOL15	VDD = 15V, VOUT = 1.5V	1, 2	+125°C	2.4	-	mA
				-55°C	4.2	-	mA
Output Current (Source)	IOH5A	VDD = 5V, VOUT = 4.6V	1, 2	+125°C	-	-0.36	mA
				-55°C	-	-0.64	mA

Specifications CD4029BMS

TABLE 3. ELECTRICAL PERFORMANCE CHARACTERISTICS (Continued)

PARAMETER	SYMBOL	CONDITIONS	NOTES	TEMPERATURE	LIMITS		UNITS
					MIN	MAX	
Output Current (Source)	IOH5B	VDD = 5V, VO _{UT} = 2.5V	1, 2	+125°C	-	-1.15	mA
				-55°C	-	-2.0	mA
Output Current (Source)	IOH10	VDD = 10V, VO _{UT} = 9.5V	1, 2	+125°C	-	-0.9	mA
				-55°C	-	-2.6	mA
Output Current (Source)	IOH15	VDD = 15V, VO _{UT} = 13.5V	1, 2	+125°C	-	-2.4	mA
				-55°C	-	-4.2	mA
Input Voltage Low	VIL	VDD = 10V, VO _H > 9V, VO _L < 1V	1, 2	+25°C, +125°C, -55°C	-	3	V
Input Voltage High	VIH	VDD = 10V, VO _H > 9V, VO _L < 1V	1, 2	+25°C, +125°C, -55°C	7	-	V
Propagation Delay Q Output	TPHL1 TPLH1	VDD = 10V	1, 2, 3	+25°C	-	240	ns
		VDD = 15V	1, 2, 3	+25°C	-	180	ns
Propagation Delay Carry Output	TPHL2 TPLH2	VDD = 10V	1, 2, 3	+25°C	-	260	ns
		VDD = 15V	1, 2, 3	+25°C	-	190	ns
Propagation Delay Preset Enable To Q	TPHL3 TPLH3	VDD = 10V	1, 2, 3	+25°C	-	200	ns
		VDD = 15V	1, 2, 3	+25°C	-	160	ns
Propagation Delay Preset Enable To Carry- Out	TPHL4 TPLH4	VDD = 10V	1, 2, 3	+25°C	-	290	ns
		VDD = 15V	1, 2, 3	+25°C	-	210	ns
Propagation Delay Carry In To Carry Out	TPHL5 TPLH5	VDD = 10V	1, 2, 3	+25°C	-	140	ns
		VDD = 15V	1, 2, 3	+25°C	-	100	ns
Transition Time	TTHL TTLH	VDD = 10V	1, 2, 3	+25°C	-	100	ns
		VDD = 15V	1, 2, 3	+25°C	-	80	ns
Maximum Clock Input Frequency	FCL	VDD = 10V	1, 2, 3	+25°C	4	-	MHz
		VDD = 15V	1, 2, 3	+25°C	5.5	-	MHz
Minimum Data Setup Time Note 4	TS	VDD = 5V	1, 2, 3	+25°C	-	340	ns
		VDD = 10V	1, 2, 3	+25°C	-	140	ns
		VDD = 15V	1, 2, 3	+25°C	-	100	ns
Clock Rise And Fall Time Note 5	TRCL TFCL	VDD = 5V	1, 2, 3	+25°C	-	15	μs
		VDD = 10V	1, 2, 3	+25°C	-	15	μs
		VDD = 15V	1, 2, 3	+25°C	-	15	μs
Minimum Clock Pulse Width	TW	VDD = 5V	1, 2, 3	+25°C	-	180	ns
		VDD = 10V	1, 2, 3	+25°C	-	90	ns
		VDD = 15V	1, 2, 3	+25°C	-	60	ns
Minimum Carry In Setup Time Note 6	TS	VDD = 5V	1, 2, 3	+25°C	-	200	ns
		VDD = 10V	1, 2, 3	+25°C	-	70	ns
		VDD = 15V	1, 2, 3	+25°C	-	60	ns
Minimum Carry Input Hold Time Note 6	TH	VDD = 5V	1, 2, 3	+25°C	-	50	ns
		VDD = 10V	1, 2, 3	+25°C	-	30	ns
		VDD = 15V	1, 2, 3	+25°C	-	25	ns
Minimum Preset Enable Removal Time Note 4	TREM	VDD = 5V	1, 2, 3	+25°C	-	200	ns
		VDD = 10V	1, 2, 3	+25°C	-	110	ns
		VDD = 15V	1, 2, 3	+25°C	-	80	ns

Specifications CD4029BMS

TABLE 3. ELECTRICAL PERFORMANCE CHARACTERISTICS (Continued)

PARAMETER	SYMBOL	CONDITIONS	NOTES	TEMPERATURE	LIMITS		UNITS
					MIN	MAX	
Minimum Preset Enable Pulse Width	TW	VDD = 5V	1, 2, 3	+25°C	-	130	ns
		VDD = 10V	1, 2, 3	+25°C	-	70	ns
		VDD = 15V	1, 2, 3	+25°C	-	50	ns
Input Capacitance	CIN	Any Input	1, 2	+25°C	-	7.5	pF

NOTES:

1. All voltages referenced to device GND.
2. The parameters listed on Table 3 are controlled via design or process and are not directly tested. These parameters are characterized on initial design release and upon design changes which would affect these characteristics.
3. CL = 50pF, RL = 200K, Input TR, TF < 20ns.
4. From Up/Down, Binary/Decode, Carry In, or Preset Enable Control Inputs to Clock Edge.
5. If more than one unit is cascaded in the parallel clocked application, tr CL should be made ≤ the sum of the fixed propagation delay at 15pF and the transition time of the carry output driving stage for the estimated capacitive load. This measurement was made with a decoupling capacitor (>1μF) between VDD and VSS.
6. From Carry In to Clock Edge.

TABLE 4. POST IRRADIATION ELECTRICAL PERFORMANCE CHARACTERISTICS

PARAMETER	SYMBOL	CONDITIONS	NOTES	TEMPERATURE	LIMITS		UNITS
					MIN	MAX	
Supply Current	IDD	VDD = 20V, VIN = VDD or GND	1, 4	+25°C	-	25	μA
N Threshold Voltage	VNTH	VDD = 10V, ISS = -10μA	1, 4	+25°C	-2.8	-0.2	V
N Threshold Voltage Delta	ΔVTN	VDD = 10V, ISS = -10μA	1, 4	+25°C	-	±1	V
P Threshold Voltage	VTP	VSS = 0V, IDD = 10μA	1, 4	+25°C	0.2	2.8	V
P Threshold Voltage Delta	ΔVTP	VSS = 0V, IDD = 10μA	1, 4	+25°C	-	±1	V
Functional	F	VDD = 18V, VIN = VDD or GND	1	+25°C	VOH > VDD/2	VOL < VDD/2	V
		VDD = 3V, VIN = VDD or GND					
Propagation Delay Time	TPHL TPLH	VDD = 5V	1, 2, 3, 4	+25°C	-	1.35 x +25°C Limit	ns

- NOTES:**
1. All voltages referenced to device GND.
 2. CL = 50pF, RL = 200K, Input TR, TF < 20ns
 3. See Table 2 for +25°C limit.
 4. Read and Record

TABLE 5. BURN-IN AND LIFE TEST DELTA PARAMETERS +25°C

PARAMETER	SYMBOL	DELTA LIMIT
Supply Current - MSI-2	IDD	± 1.0μA
Output Current (Sink)	IOL5	± 20% x Pre-Test Reading
Output Current (Source)	IOH5A	± 20% x Pre-Test Reading

Specifications CD4029BMS

TABLE 6. APPLICABLE SUBGROUPS

CONFORMANCE GROUP		MIL-STD-883 METHOD	GROUP A SUBGROUPS	READ AND RECORD
Initial Test (Pre Burn-In)		100% 5004	1, 7, 9	IDD, IOL5, IOH5A
Interim Test 1 (Post Burn-In)		100% 5004	1, 7, 9	IDD, IOL5, IOH5A
Interim Test 2 (Post Burn-In)		100% 5004	1, 7, 9	IDD, IOL5, IOH5A
PDA (Note 1)		100% 5004	1, 7, 9, Deltas	
Interim Test 3 (Post Burn-In)		100% 5004	1, 7, 9	IDD, IOL5, IOH5A
PDA (Note 1)		100% 5004	1, 7, 9, Deltas	
Final Test		100% 5004	2, 3, 8A, 8B, 10, 11	
Group A		Sample 5005	1, 2, 3, 7, 8A, 8B, 9, 10, 11	
Group B	Subgroup B-5	Sample 5005	1, 2, 3, 7, 8A, 8B, 9, 10, 11, Deltas	Subgroups 1, 2, 3, 9, 10, 11
	Subgroup B-6	Sample 5005	1, 7, 9	
Group D		Sample 5005	1, 2, 3, 8A, 8B, 9	Subgroups 1, 2 3

NOTE: 1. 5% Parametric, 3% Functional; Cumulative for Static 1 and 2.

TABLE 7. TOTAL DOSE IRRADIATION

CONFORMANCE GROUPS	MIL-STD-883 METHOD	TEST		READ AND RECORD	
		PRE-IRRAD	POST-IRRAD	PRE-IRRAD	POST-IRRAD
Group E Subgroup 2	5005	1, 7, 9	Table 4	1, 9	Table 4

TABLE 8. BURN-IN AND IRRADIATION TEST CONNECTIONS

FUNCTION	OPEN	GROUND	VDD	9V ± -0.5V	OSCILLATOR	
					50kHz	25kHz
Static Burn-In 1 Note 1	2, 6, 7, 11, 14	1, 3 - 5, 8 - 10, 12, 13, 15	16			
Static Burn-In 2 Note 1	2, 6, 7, 11, 14	8	1, 3 - 5, 9, 10, 12, 13, 15, 16			
Dynamic Burn-In Note 1	-	1, 3 - 5, 8, 12, 13	9, 10, 16	2, 6, 7, 11, 14	15	-
Irradiation Note 2	2, 6, 7, 11, 14	8	1, 3 - 5, 9, 10, 12, 13, 15, 16			

NOTE:

- Each pin except VDD and GND will have a series resistor of $10K \pm 5\%$, $VDD = 18V \pm 0.5V$
- Each pin except VDD and GND will have a series resistor of $47K \pm 5\%$; Group E, Subgroup 2, sample size is 4 dice/wafer, 0 failures, $VDD = 10V \pm 0.5V$

CD4029BMS

Logic Diagram

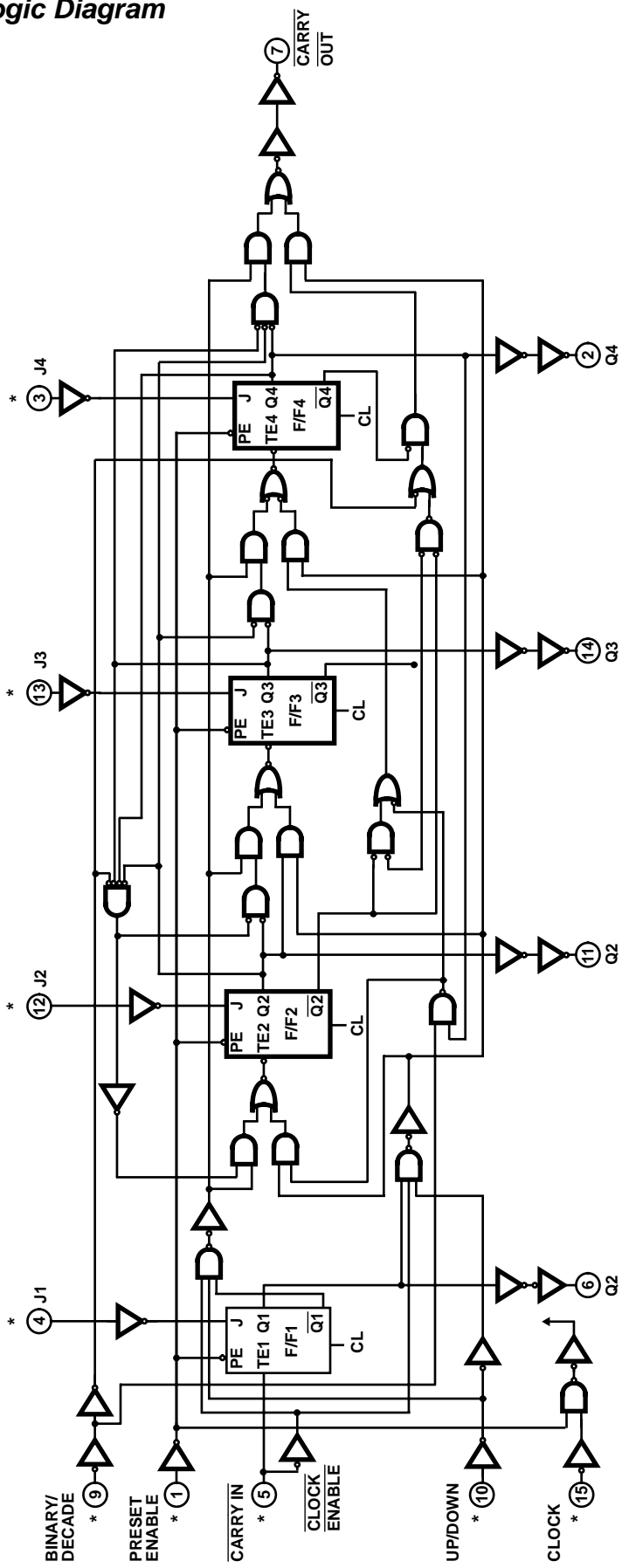

FUNCTION TABLE

CONTROL INPUT	LOGIC LEVEL	ACTION
BIN/DEC (B/D)	1	Binary Count
BIN/DEC (B/D)	0	Decade Count
UP/DOWN (U/D)	1	Up Count
UP/DOWN (U/D)	0	Down Count
Preset Enable (PE)	1	Jam In
Preset Enable (PE)	0	No Jam
CARRY IN (\bar{C}_i)	1	No Counter Advance at POS Clock Transition
CARRY IN (\bar{C}_i)	0	Advance Counter at POS Clock Transition

TRUTH TABLE

CLOCK	TE	PE	J	Q	\bar{Q}
X	X	0	0	0	1
$\overline{\text{Clock}}$	0	1	X	\bar{Q}	Q
X	X	0	1	1	0
$\overline{\text{Clock}}$	1	1	X	Q	\bar{Q}
$\overline{\text{Clock}}$	X	1	X	Q	Q

X = Don't Care

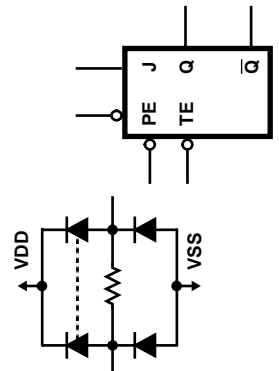

* ALL INPUTS ARE PROTECTED BY CMOS PROTECTION NETWORK

FIGURE 1.

CD4029BMS

Typical Performance Characteristics

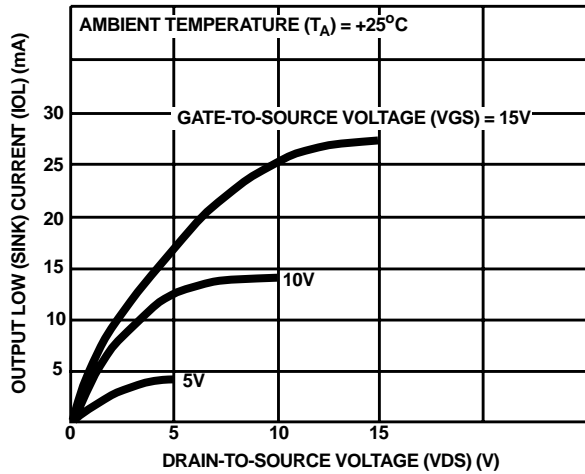

FIGURE 2. TYPICAL OUTPUT LOW (SINK) CURRENT CHARACTERISTICS

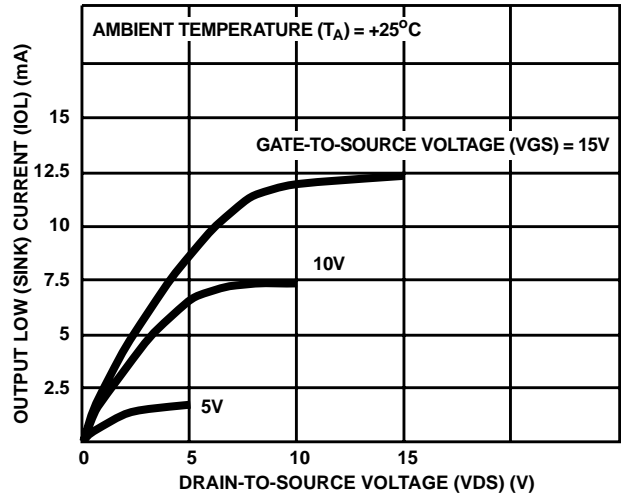

FIGURE 3. MINIMUM OUTPUT LOW (SINK) CURRENT CHARACTERISTICS

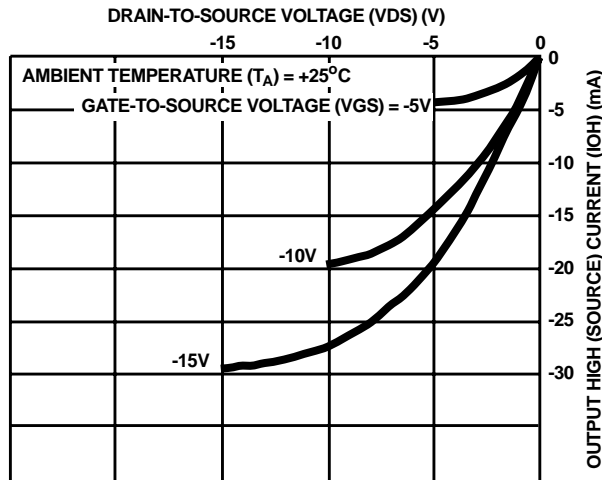

FIGURE 4. TYPICAL OUTPUT HIGH (SOURCE) CURRENT CHARACTERISTICS

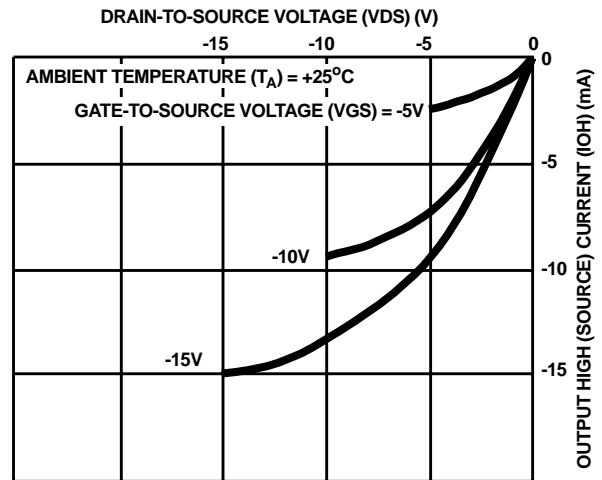

FIGURE 5. MINIMUM OUTPUT HIGH (SOURCE) CURRENT CHARACTERISTICS

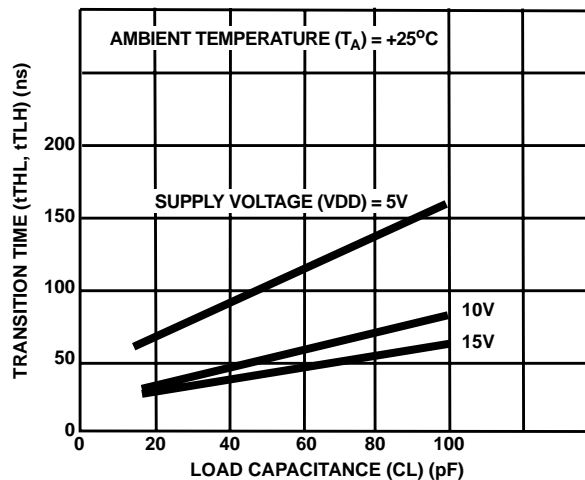

FIGURE 6. TYPICAL TRANSITION TIME AS A FUNCTION OF LOAD CAPACITANCE

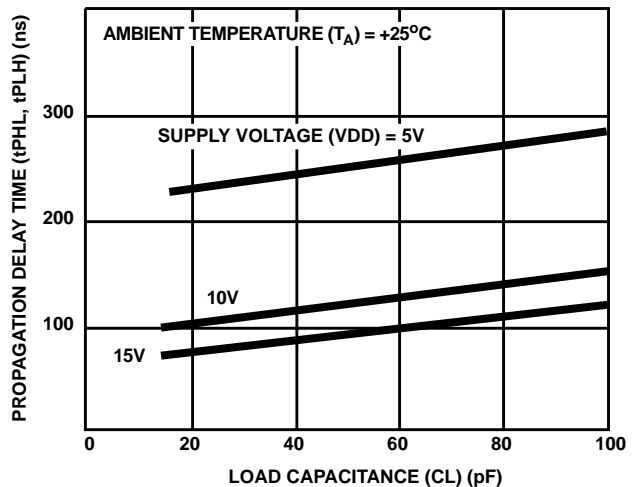

FIGURE 7. TYPICAL PROPAGATION DELAY TIME AS A FUNCTION OF LOAD CAPACITANCE (Q OUTPUT)

CD4029BMS

Typical Performance Characteristics (Continued)

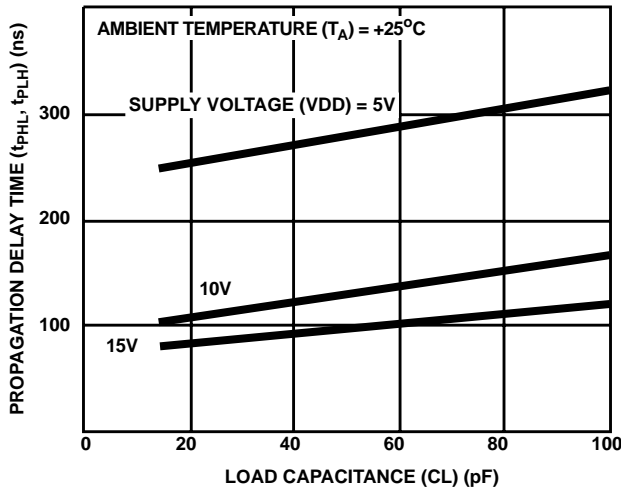

FIGURE 8. TYPICAL PROPAGATION DELAY TIME AS A FUNCTION OF LOAD CAPACITANCE (CARRY OUTPUT)

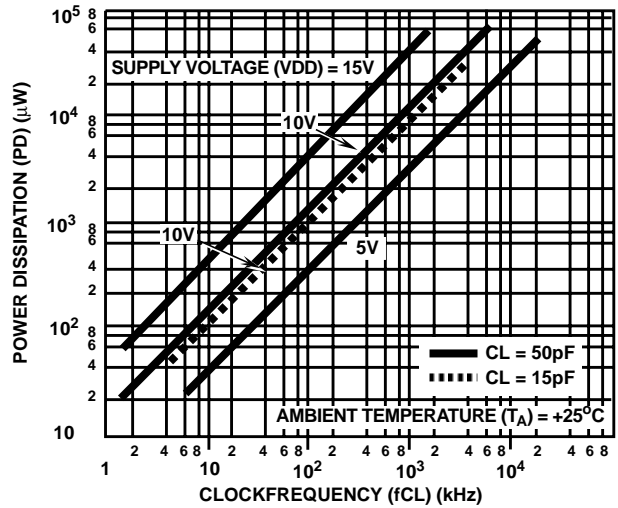
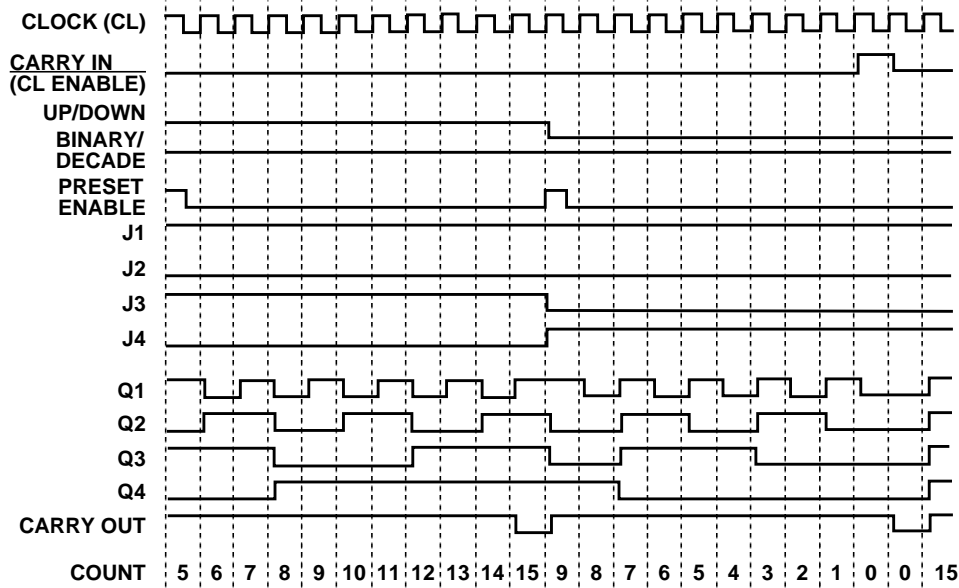

FIGURE 9. TYPICAL POWER DISSIPATION AS A FUNCTION OF FREQUENCY

Timing Diagrams



The CD4029BMS CLOCK and UP/DOWN inputs are used directly in most applications. In applications where CLOCK UP and CLOCK DOWN inputs are provided, conversion to the CD4029BMS CLOCK and UP/DOWN inputs can easily be realized by use of the circuit in Figure 11.

CD4029BMS changes count on positive transitions of CLOCK UP or CLOCK DOWN inputs. For the gate configuration in Figure 12, when counting up the CLOCK DOWN input must be maintained high and conversely when counting down the CLOCK UP input must be maintained high.

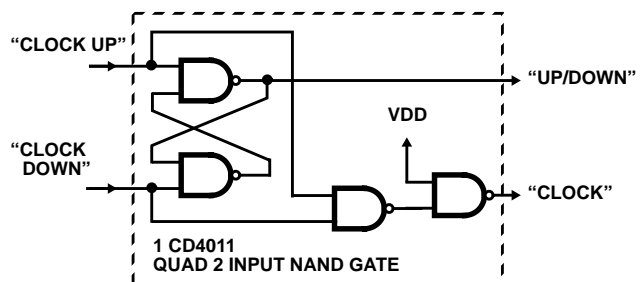

FIGURE 11. CONVERSION OF CLOCK UP, CLOCK DOWN INPUT SIGNALS TO CLOCK AND UP/DOWN INPUT SIGNALS

CD4029BMS

Timing Diagrams (Continued)

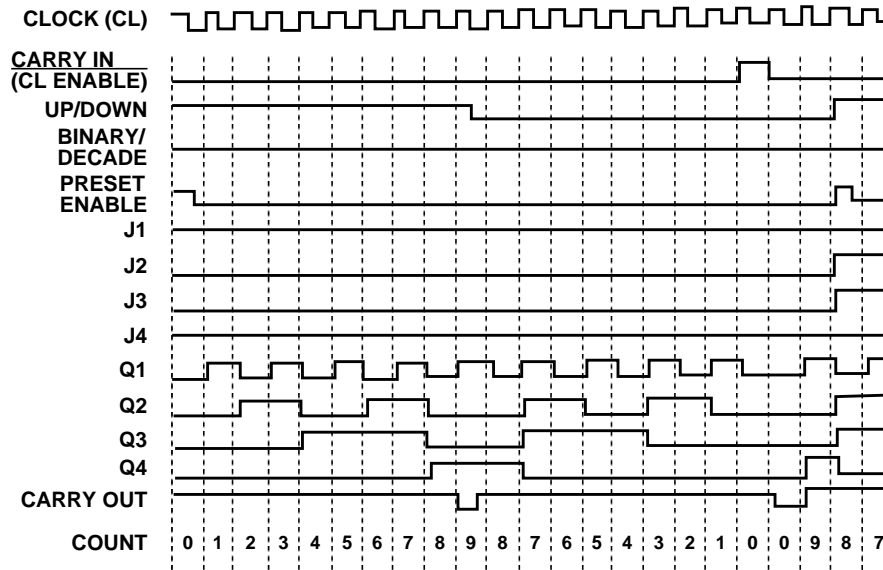
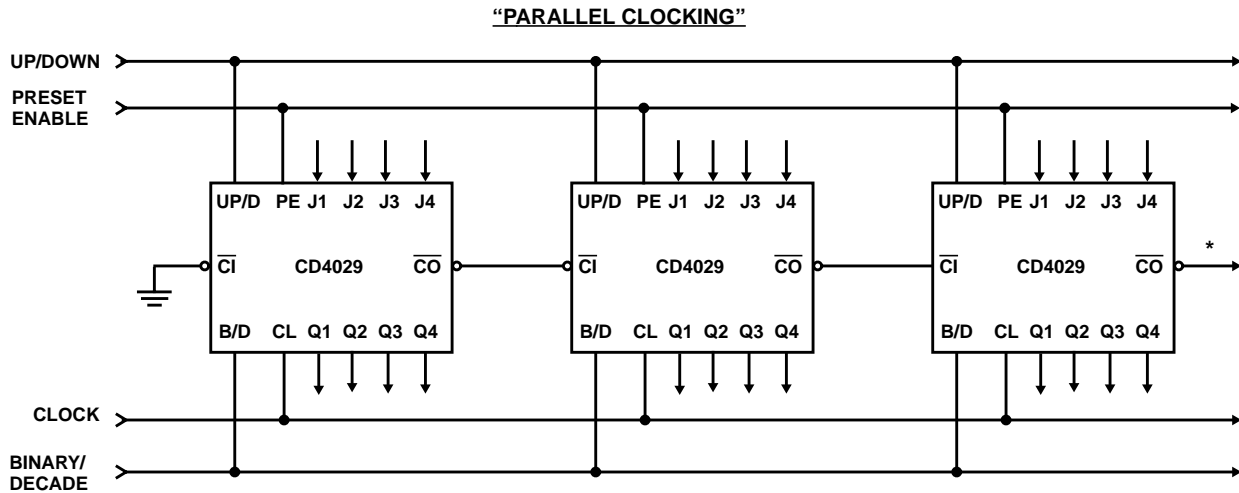

FIGURE 12. TIMING DIAGRAM-DECADE MODE



*CARRY OUT LINES AT THE 2ND, 3RD, ETC, STAGES MAY HAVE A NEGATIVE-GOING GLITCH PULSE RESULTING FROM DIFFERENTIAL DELAYS OF DIFFERENT CD4029BMS IC'S. THESE NEGATIVE GOING GLITCHES DO NOT AFFECT PROPER CD4029BMS OPERATION. HOWEVER, IF THE CARRY OUT SIGNALS ARE USED TO TRIGGER OTHER EDGE-SENSITIVE LOGIC DEVICES, SUCH AS FF'S OR COUNTERS, THE CARRY OUT SIGNALS SHOULD BE GATED WITH THE CLOCK SIGNAL USING A 2-INPUT OR GATE SUCH AS CD4071BMS.

FIGURE 13. CASCADING COUNTER PACKAGES

All Intersil semiconductor products are manufactured, assembled and tested under **ISO9000** quality systems certification.

Intersil products are sold by description only. Intersil Corporation reserves the right to make changes in circuit design and/or specifications at any time without notice. Accordingly, the reader is cautioned to verify that data sheets are current before placing orders. Information furnished by Intersil is believed to be accurate and reliable. However, no responsibility is assumed by Intersil or its subsidiaries for its use; nor for any infringements of patents or other rights of third parties which may result from its use. No license is granted by implication or otherwise under any patent or patent rights of Intersil or its subsidiaries.

CD4029BMS

Timing Diagrams (Continued)

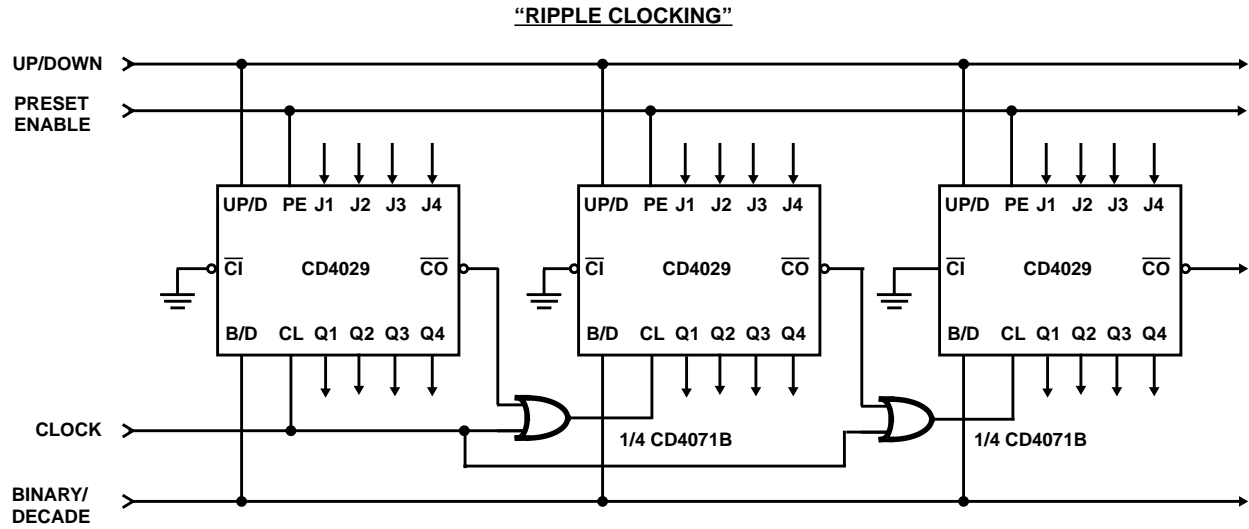

RIPPLE CLOCKING MODE:

THE UP/DOWN CONTROL CAN BE CHANGED AT ANY COUNT. THE ONLY RESTRICTION ON CHANGING THE UP/DOWN CONTROL IS THAT THE CLOCK INPUT TO THE FIRST COUNTING STAGE MUST BE HIGH. FOR CASCADING COUNTERS OPERATING IN A FIXED UP-COUNT OR DOWN-COUNT MODE, THE OR GATES ARE NOT REQUIRED BETWEEN STAGES, AND \overline{CO} IS CONNECTED DIRECTLY TO THE CL INPUT OF THE NEXT STAGE WITH \overline{CI} GROUNDED.

FIGURE 13. CASCADING COUNTER PACKAGES (Continued)

Chip Dimensions and Pad Layout

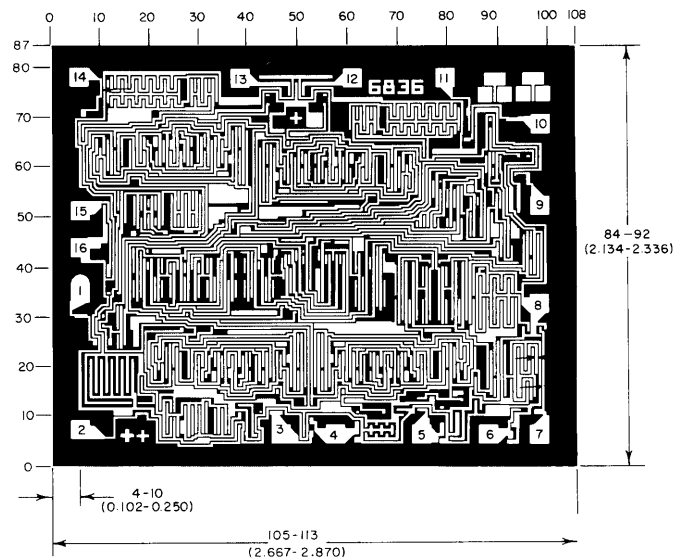

Dimensions in parentheses are in millimeters and are derived from the basic inch dimensions as indicated. Grid graduations are in mils (10^{-3} inch)

METALLIZATION: Thickness: $11\text{k}\text{\AA} - 14\text{k}\text{\AA}$, AL.

PASSIVATION: $10.4\text{k}\text{\AA} - 15.6\text{k}\text{\AA}$, Silane

BOND PADS: 0.004 inches X 0.004 inches MIN

DIE THICKNESS: 0.0198 inches - 0.0218 inches