



**HIGH-SPEED 3.3V
128K x9/x8
SYNCHRONOUS PIPELINED
DUAL-PORT STATIC RAM**

IDT70V9199/099L

Features:

- ◆ True Dual-Ported memory cells which allow simultaneous access of the same memory location
- ◆ High-speed clock to data access
 - Commercial: 6/7.5/9/12ns (max.)
 - Industrial: 9ns (max.)
- ◆ Low-power operation
 - IDT70V9199/099L
 - Active: 500mW (typ.)
 - Standby: 1.5mW (typ.)
- ◆ Flow-Through or Pipelined output mode on either port via the $\overline{\text{FT}}/\text{PIPEL}$ pins
- ◆ Dual chip enables allow for depth expansion without additional logic
- ◆ Counter enable and reset features
- ◆ Full synchronous operation on both ports
 - 3.5ns setup to clock and 0ns hold on all control, data, and address inputs
 - Data input, address, and control registers
 - Fast 6.5ns clock to data out in the Pipelined output mode
 - Self-timed write allows fast cycle time
 - 10ns cycle time, 100MHz operation in Pipelined output mode
- ◆ LVTTTL-compatible, single 3.3V ($\pm 0.3\text{V}$) power supply
- ◆ Industrial temperature range (-40°C to $+85^\circ\text{C}$) is available for selected speeds
- ◆ Available in a 100-pin Thin Quad Flatpack (TQFP)

Functional Block Diagram

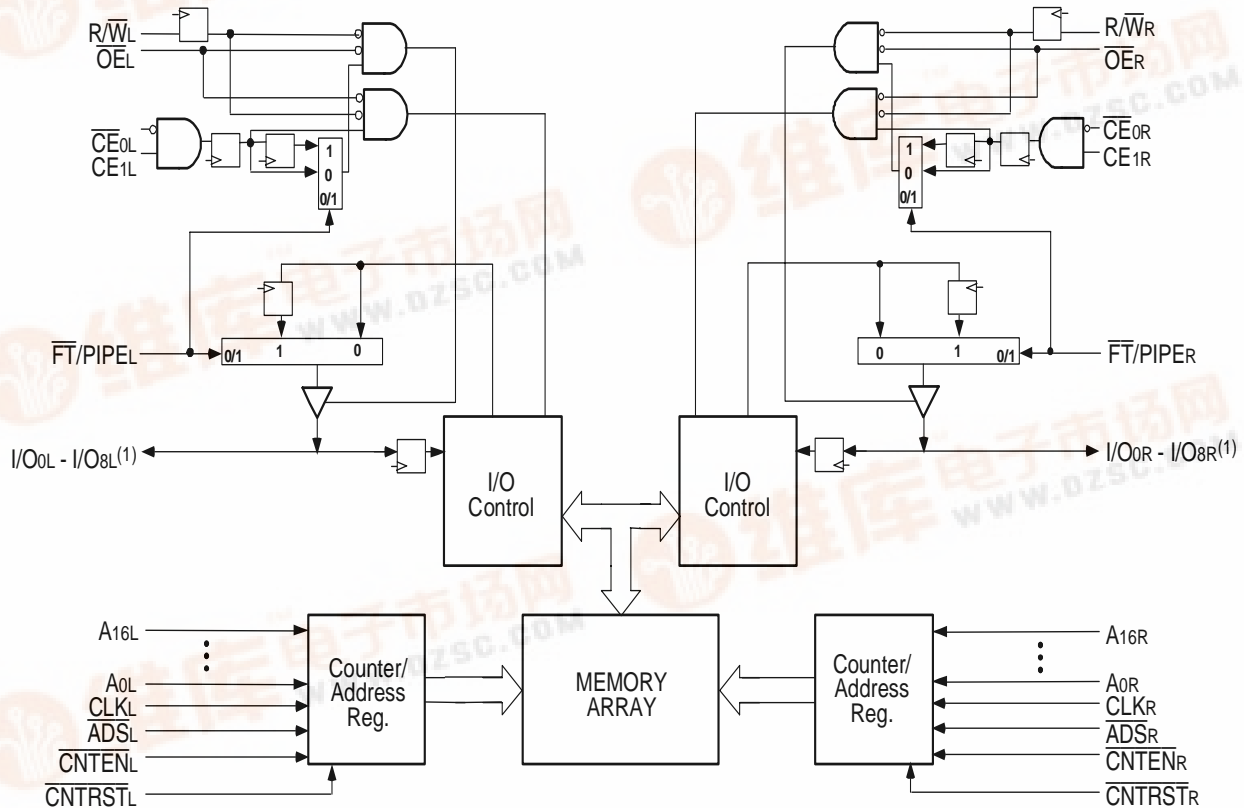

4859 drw 01

NOTE:
1 I/O0x - I/O7x for IDT70V9099.



Description:

The IDT70V9199/099 is a high-speed 128K x9/x8 bit synchronous Dual-Port RAM. The memory array utilizes Dual-Port memory cells to allow simultaneous access of any address from both ports. Registers on control, data, and address inputs provide minimal setup and hold times. The timing latitude provided by this approach allows systems to be designed with very short cycle times.

With an input data register, the IDT70V9199/099 has been optimized for applications having unidirectional or bidirectional data flow in bursts. An automatic power down feature, controlled by $\overline{CE0}$ and $CE1$, permits the on-chip circuitry of each port to enter a very low standby power mode. Fabricated using IDT's CMOS high-performance technology, these devices typically operate on only 500mW of power.

Pin Configuration^(1,2,3)

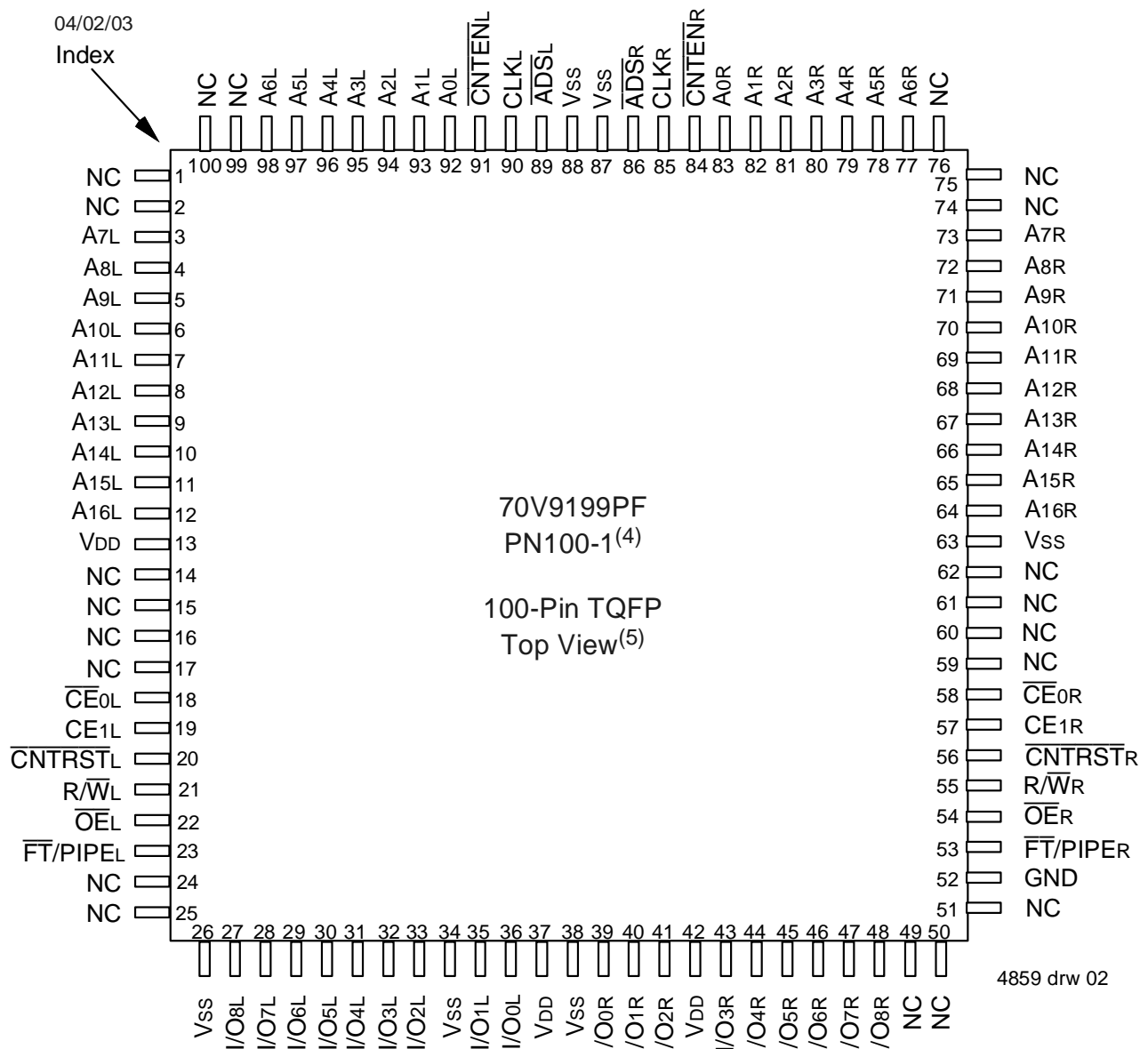

NOTES:

1. All VDD pins must be connected to power supply.
2. All VSS pins must be connected to ground supply.
3. Package body is approximately 14mm x 14mm x 1.4mm.
4. This package code is used to reference the package diagram.
5. This text does not indicate orientation of the actual part-marking.

Pin Configuration^(1,2,3)(con't.)

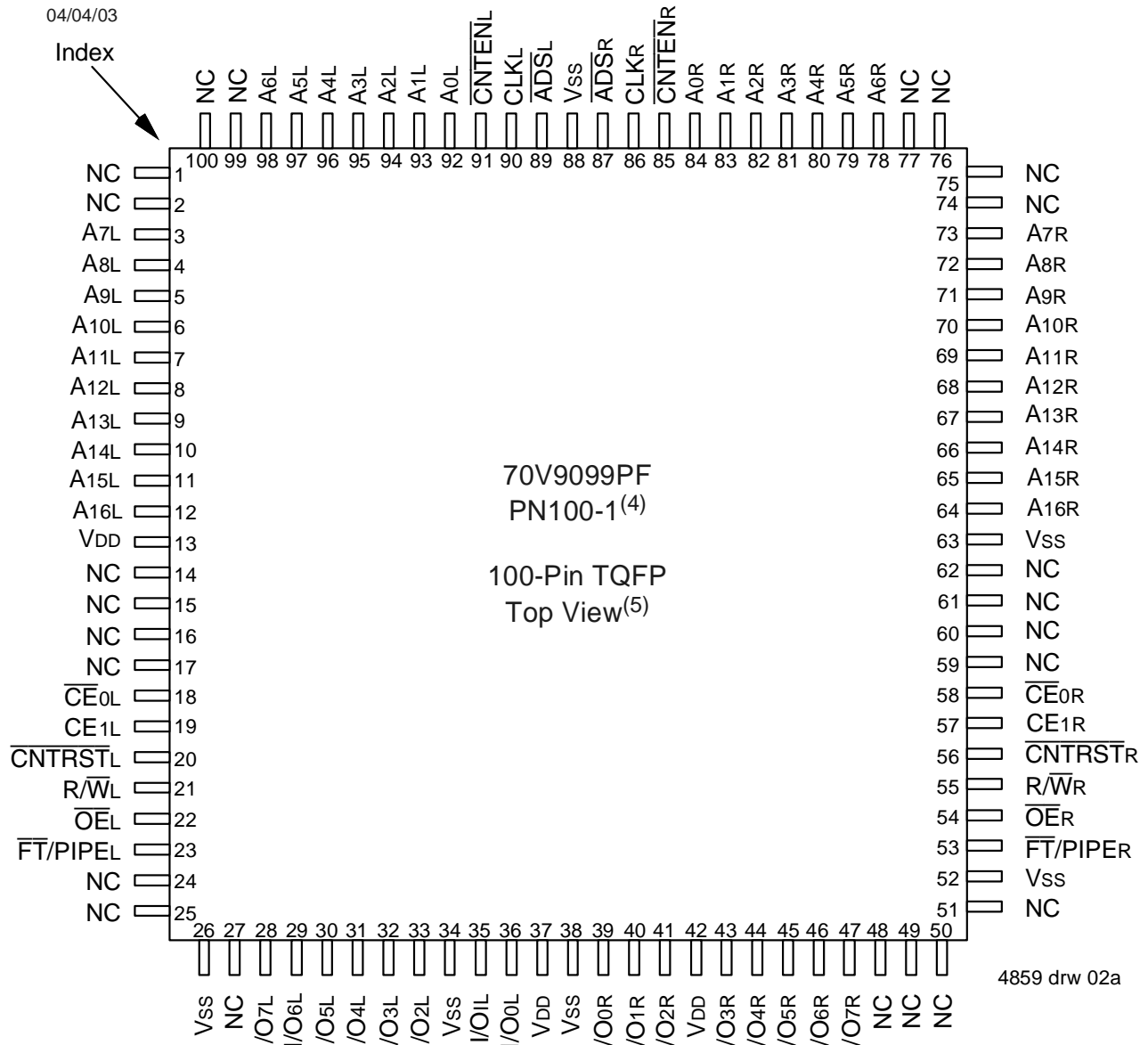

NOTES:

1. All VDD pins must be connected to power supply.
2. All VSS pins must be connected to ground.
3. Package body is approximately 14mm x 14mm x 1.4mm.
4. This package code is used to reference the package diagram.
5. This text does not indicate orientation of the actual part-marking.

Pin Names

Left Port	Right Port	Names
$\overline{CE}0L, CE1L$	$\overline{CE}0R, CE1R$	Chip Enables
R/\overline{WL}	R/\overline{WR}	Read/Write Enable
$\overline{OE}L$	$\overline{OE}R$	Output Enable
A0L - A16L	A0R - A16R	Address
I/O0L - I/O8L ⁽¹⁾	I/O0R - I/O8R ⁽¹⁾	Data Input/Output
CLKL	CLKR	Clock
\overline{ADSL}	\overline{ADSR}	Address Strobe Enable
\overline{CNTENL}	\overline{CNTENR}	Counter Enable
$\overline{CNTRSTL}$	$\overline{CNTRSTR}$	Counter Reset
$\overline{FT}/PIPEL$	$\overline{FT}/PIPER$	Flow-Through / Pipeline
VDD		Power (3.3V)
VSS		Ground (0V)

NOTE:

1. I/O0x - I/O7x for IDT70V9099.

4859 tbl 01

Truth Table I—Read/Write and Enable Control^(1,2,3)

\overline{OE}	CLK	$\overline{CE}0$	CE1	R/ \overline{W}	I/O0-3 ⁽⁴⁾	MODE
X	↑	H	X	X	High-Z	Deselected—Power Down
X	↑	X	L	X	High-Z	Deselected—Power Down
X	↑	L	H	L	DATA _{IN}	Write
L	↑	L	H	H	DATA _{OUT}	Read
H	X	L	H	X	High-Z	Outputs Disabled

4859 tbl 02

NOTES:

- "H" = V_{IH}, "L" = V_{IL}, "X" = Don't Care.
- \overline{ADS} , \overline{CNTEN} , \overline{CNTRST} = X.
- \overline{OE} is an asynchronous input signal.
- I/O0 - I/O7 for IDT70V9099.

Truth Table II—Address Counter Control^(1,2)

External Address	Previous Internal Address	Internal Address Used	CLK	\overline{ADS}	\overline{CNTEN}	\overline{CNTRST}	I/O ⁽³⁾	MODE
X	X	0	↑	X	X	L ⁽⁴⁾	D _{I/O} (0)	Counter Reset to Address 0
A _n	X	A _n	↑	L ⁽⁴⁾	X	H	D _{I/O} (n)	External Address Loaded into Counter
A _n	A _p	A _p	↑	H	H	H	D _{I/O} (p)	External Address Blocked—Counter disabled (A _p reused)
X	A _p	A _p + 1	↑	H	L ⁽⁵⁾	H	D _{I/O} (p+1)	Counter Enabled—Internal Address generation

4859 tbl 03

NOTES:

- "H" = V_{IH}, "L" = V_{IL}, "X" = Don't Care.
- $\overline{CE}0$ and \overline{OE} = V_{IL}; CE1 and R/ \overline{W} = V_{IH}.
- Outputs configured in Flow-Through Output mode; if outputs are in Pipelined mode the data out will be delayed by one cycle.
- \overline{ADS} and \overline{CNTRST} are independent of all other signals including $\overline{CE}0$ and CE1.
- The address counter advances if \overline{CNTEN} = V_{IL} on the rising edge of CLK, regardless of all other signals including $\overline{CE}0$ and CE1.

Recommended Operating Temperature and Supply Voltage⁽¹⁾

Grade	Ambient Temperature ⁽²⁾	GND	VDD
Commercial	0°C to +70°C	0V	3.3V \pm 0.3V
Industrial	-40°C to +85°C	0V	3.3V \pm 0.3V

4859 tbl 04

NOTES:

- This is the parameter TA. This is the "instant on" case temperature.

Recommended DC Operating Conditions

Symbol	Parameter	Min.	Typ.	Max.	Unit
VDD	Supply Voltage	3.0	3.3	3.6	V
VSS	Ground	0	0	0	V
VIH	Input High Voltage	2.0	—	VDD+0.3V ⁽²⁾	V
VIL	Input Low Voltage	-0.3 ⁽¹⁾	—	0.8	V

4859 tbl 05

NOTES:

- VIL \geq -1.5V for pulse width less than 10 ns.
- VTERM must not exceed VDD +0.3V.

Absolute Maximum Ratings⁽¹⁾

Symbol	Rating	Commercial & Industrial	Unit
VTERM ⁽²⁾	Terminal Voltage with Respect to GND	-0.5 to +4.6	V
TBIAS ⁽³⁾	Temperature Under Bias	-55 to +125	°C
TSTG	Storage Temperature	-65 to +150	°C
TJN	Junction Temperature	+150	°C
IOUT	DC Output Current	50	mA

4859 tbl 06

NOTES:

- Stresses greater than those listed under ABSOLUTE MAXIMUM RATINGS may cause permanent damage to the device. This is a stress rating only and functional operation of the device at these or any other conditions above those indicated in the operational sections of this specification is not implied. Exposure to absolute maximum rating conditions for extended periods may affect reliability.
- VTERM must not exceed VDD +0.3V for more than 25% of the cycle time or 10ns maximum, and is limited to \leq 20mA for the period of VTERM \geq VDD + 0.3V.
- Ambient Temperature Under DC Bias. No AC Conditions. Chip deselected.

Capacitance⁽¹⁾

(TA = +25°C, f = 1.0MHz)

Symbol	Parameter	Conditions ⁽²⁾	Max.	Unit
CIN	Input Capacitance	VIN = 3dV	9	pF
COU ⁽³⁾	Output Capacitance	VOUT = 3dV	10	pF

4859 tbl 07

NOTES:

- These parameters are determined by device characterization, but are not production tested.
- 3dV references the interpolated capacitance when the input and output switch from 0V to 3V or from 3V to 0V.
- COU also references CIO.

DC Electrical Characteristics Over the Operating Temperature and Supply Voltage Range (VDD = 3.3V \pm 0.3V)

Symbol	Parameter	Test Conditions	70V9199/099L		Unit
			Min.	Max.	
ILI	Input Leakage Current ⁽¹⁾	VDD = 3.6V, VIN = 0V to VDD	—	5	μ A
ILO	Output Leakage Current	\overline{CE} = VIH or CE1 = VIL, VOUT = 0V to VDD	—	5	μ A
VOL	Output Low Voltage	IOL = +4mA	—	0.4	V
VOH	Output High Voltage	I OH = -4mA	2.4	—	V

4859 tbl 08

NOTE:

- At VDD \leq 2.0V input leakages are undefined.

DC Electrical Characteristics Over the Operating Temperature Supply Voltage Range⁽³⁾ ($V_{DD} = 3.3V \pm 0.3V$)

Symbol	Parameter	Test Condition	Version	70V9199/099L6 Com'l Only		70V9199/099L7 Com'l Only		70V9199/099L9 Com'l & Ind		70V9199/099L12 Com'l Only		Unit	
				Typ. ⁽⁴⁾	Max.	Typ. ⁽⁴⁾	Max.	Typ. ⁽⁴⁾	Max.	Typ. ⁽⁴⁾	Max.		
IDD	Dynamic Operating Current (Both Ports Active)	\overline{CE}_L and $\overline{CE}_R = V_{IL}$, Outputs Disabled, $f = f_{MAX}^{(1)}$	COM'L	L	220	280	200	250	175	230	150	200	mA
			IND	L	—	—	—	—	180	240	—	—	
ISB1	Standby Current (Both Ports - TTL Level Inputs)	$\overline{CE}_L = \overline{CE}_R = V_{IH}$ $f = f_{MAX}^{(1)}$	COM'L	L	60	85	50	75	40	65	30	50	mA
			IND	L	—	—	—	—	50	70	—	—	
ISB2	Standby Current (One Port - TTL Level Inputs)	$\overline{CE}^*A = V_{IL}$ and $\overline{CE}^*B = V_{IH}^{(5)}$ Active Port Outputs Disabled, $f = f_{MAX}^{(1)}$	COM'L	L	145	185	130	165	110	145	95	130	mA
			IND	L	—	—	—	—	110	155	—	—	
ISB3	Full Standby Current (Both Ports - CMOS Level Inputs)	Both Ports \overline{CE}_L and $\overline{CE}_R \geq V_{DD} - 0.2V$, $V_{IN} \geq V_{DD} - 0.2V$ or $V_{IN} \leq 0.2V$, $f = 0^{(2)}$	COM'L	L	0.4	2	0.4	2	0.4	2	0.4	2	mA
			IND	L	—	—	—	—	0.4	2	—	—	
ISB4	Full Standby Current (One Port - CMOS Level Inputs)	$\overline{CE}^*A \leq 0.2V$ and $\overline{CE}^*B \geq V_{DD} - 0.2V^{(6)}$ $V_{IN} \geq V_{DD} - 0.2V$ or $V_{IN} \leq 0.2V$, Active Port, Outputs Disabled, $f = f_{MAX}^{(1)}$	COM'L	L	145	180	130	160	100	140	90	125	mA
			IND	L	—	—	—	—	100	155	—	—	

4859 tbl 09

NOTES:

- At $f = f_{MAX}$, address and control lines (except Output Enable) are cycling at the maximum frequency clock cycle of $1/t_{cvc}$, using "AC TEST CONDITIONS" at input levels of GND to 3V.
- $f = 0$ means no address, clock, or control lines change. Applies only to input at CMOS level standby.
- Port "A" may be either left or right port. Port "B" is the opposite from port "A".
- $V_{DD} = 3.3V$, $T_A = 25^\circ C$ for Typ, and are not production tested. $I_{DD} \text{ dc}(f=0) = 90\text{mA}$ (Typ).
- $\overline{CE}_X = V_{IL}$ means $\overline{CE}_{0X} = V_{IL}$ and $CE_{1X} = V_{IH}$
 $\overline{CE}_X = V_{IH}$ means $\overline{CE}_{0X} = V_{IH}$ or $CE_{1X} = V_{IL}$
 $\overline{CE}_X \leq 0.2V$ means $\overline{CE}_{0X} \leq 0.2V$ and $CE_{1X} \geq V_{DD} - 0.2V$
 $\overline{CE}_X \geq V_{DD} - 0.2V$ means $\overline{CE}_{0X} \geq V_{DD} - 0.2V$ or $CE_{1X} \leq 0.2V$
"X" represents "L" for left port or "R" for right port.

AC Test Conditions

Input Pulse Levels	GND to 3.0V
Input Rise/Fall Times	3ns Max.
Input Timing Reference Levels	1.5V
Output Reference Levels	1.5V
Output Load	Figures 1, 2, and 3

4859 tbl 10

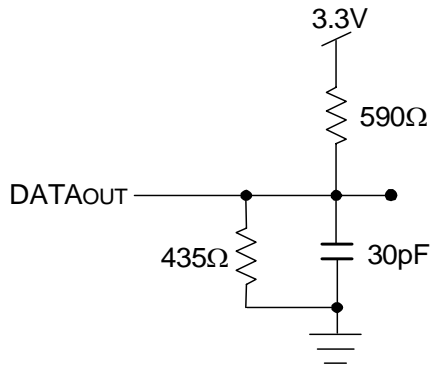

4859 drw 03

Figure 1. AC Output Test load.

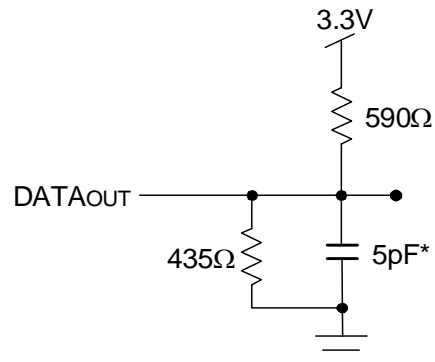

4859 drw 04

Figure 2. Output Test Load
(For t_{CKLZ}, t_{CKHZ}, t_{OLZ}, and t_{OHZ}).
*Including scope and jig.

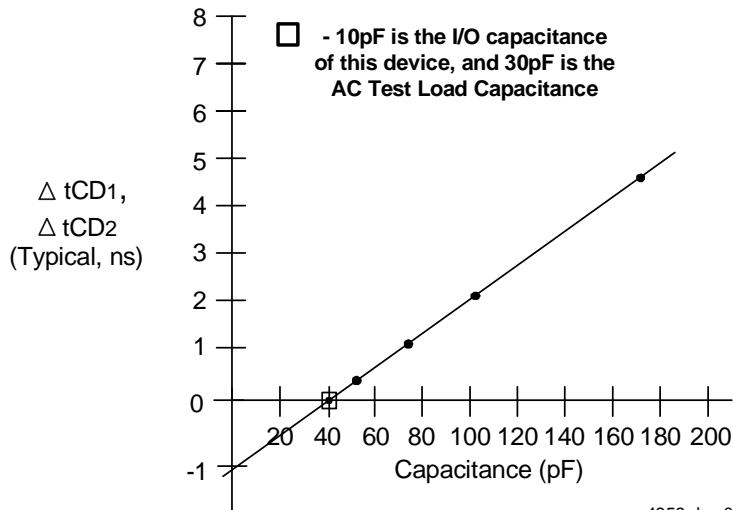

4859 drw 05

Figure 3. Typical Output Derating (Lumped Capacitive Load).

AC Electrical Characteristics Over the Operating Temperature Range (Read and Write Cycle Timing)⁽³⁾ (V_{DD} = 3.3V ± 0.3V, T_A = 0°C to +70°C)

Symbol	Parameter	70V9199/099L6 Com'l Only		70V9199/099L7 Com'l Only		70V9199/099L9 Com'l & Ind		70V9199/099L12 Com'l Only		Unit
		Min.	Max.	Min.	Max.	Min.	Max.	Min.	Max.	
t _{CYC1}	Clock Cycle Time (Flow-Through) ⁽²⁾	19	—	22	—	25	—	30	—	ns
t _{CYC2}	Clock Cycle Time (Pipelined) ⁽²⁾	10	—	12	—	15	—	20	—	ns
t _{CH1}	Clock High Time (Flow-Through) ⁽²⁾	6.5	—	7.5	—	12	—	12	—	ns
t _{CL1}	Clock Low Time (Flow-Through) ⁽²⁾	6.5	—	7.5	—	12	—	12	—	ns
t _{CH2}	Clock High Time (Pipelined) ⁽²⁾	4	—	5	—	6	—	8	—	ns
t _{CL2}	Clock Low Time (Pipelined) ⁽²⁾	4	—	5	—	6	—	8	—	ns
t _r	Clock Rise Time	—	3	—	3	—	3	—	3	ns
t _f	Clock Fall Time	—	3	—	3	—	3	—	3	ns
t _{SA}	Address Setup Time	3.5	—	4	—	4	—	4	—	ns
t _{HA}	Address Hold Time	0	—	0	—	1	—	1	—	ns
t _{SC}	Chip Enable Setup Time	3.5	—	4	—	4	—	4	—	ns
t _{HC}	Chip Enable Hold Time	0	—	0	—	1	—	1	—	ns
t _{SW}	R/W Setup Time	3.5	—	4	—	4	—	4	—	ns
t _{HW}	R/W Hold Time	0	—	0	—	1	—	1	—	ns
t _{SD}	Input Data Setup Time	3.5	—	4	—	4	—	4	—	ns
t _{HD}	Input Data Hold Time	0	—	0	—	1	—	1	—	ns
t _{SAD}	$\overline{\text{ADS}}$ Setup Time	3.5	—	4	—	4	—	4	—	ns
t _{HAD}	$\overline{\text{ADS}}$ Hold Time	0	—	0	—	1	—	1	—	ns
t _{SCN}	$\overline{\text{CNTEN}}$ Setup Time	3.5	—	4	—	4	—	4	—	ns
t _{HCN}	$\overline{\text{CNTEN}}$ Hold Time	0	—	0	—	1	—	1	—	ns
t _{SRST}	$\overline{\text{CNTRST}}$ Setup Time	3.5	—	4	—	4	—	4	—	ns
t _{HRST}	$\overline{\text{CNTRST}}$ Hold Time	0	—	0	—	1	—	1	—	ns
t _{OE}	Output Enable to Data Valid	—	6.5	—	7.5	—	9	—	12	ns
t _{OLZ}	Output Enable to Output Low-Z ⁽¹⁾	2	—	2	—	2	—	2	—	ns
t _{OHZ}	Output Enable to Output High-Z ⁽¹⁾	1	7	1	7	1	7	1	7	ns
t _{CD1}	Clock to Data Valid (Flow-Through) ⁽²⁾	—	15	—	18	—	20	—	25	ns
t _{CD2}	Clock to Data Valid (Pipelined) ⁽²⁾	—	6.5	—	7.5	—	9	—	12	ns
t _{DC}	Data Output Hold After Clock High	2	—	2	—	2	—	2	—	ns
t _{CKHZ}	Clock High to Output High-Z ⁽¹⁾	2	9	2	9	2	9	2	9	ns
t _{CKLZ}	Clock High to Output Low-Z ⁽¹⁾	2	—	2	—	2	—	2	—	ns
Port-to-Port Delay										
t _{CWDD}	Write Port Clock High to Read Data Delay	—	24	—	28	—	35	—	40	ns
t _{CSS}	Clock-to-Clock Setup Time	—	8	—	10	—	15	—	15	ns

4859 tbl 11

NOTES:

- Transition is measured 0mV from Low or High-impedance voltage with the Output Test Load (Figure 2). This parameter is guaranteed by device characterization, but is not production tested.
- The Pipelined output parameters (t_{CYC2}, t_{CD2}) apply to either or both the Left and Right ports when $\overline{\text{FT}}/\text{PIPE} = \text{V}_{\text{IH}}$. Flow-through parameters (t_{CYC1}, t_{CD1}) apply when $\overline{\text{FT}}/\text{PIPE} = \text{V}_{\text{IL}}$ for that port.
- All input signals are synchronous with respect to the clock except for the asynchronous Output Enable ($\overline{\text{OE}}$), $\overline{\text{FT}}/\text{PIPER}$, and $\overline{\text{FT}}/\text{PIPEL}$.

Timing Waveform of Read Cycle for Flow-Through Output ($\overline{FT}/\text{PIPE}^{\text{X}} = V_{IL}$)^(3,6)

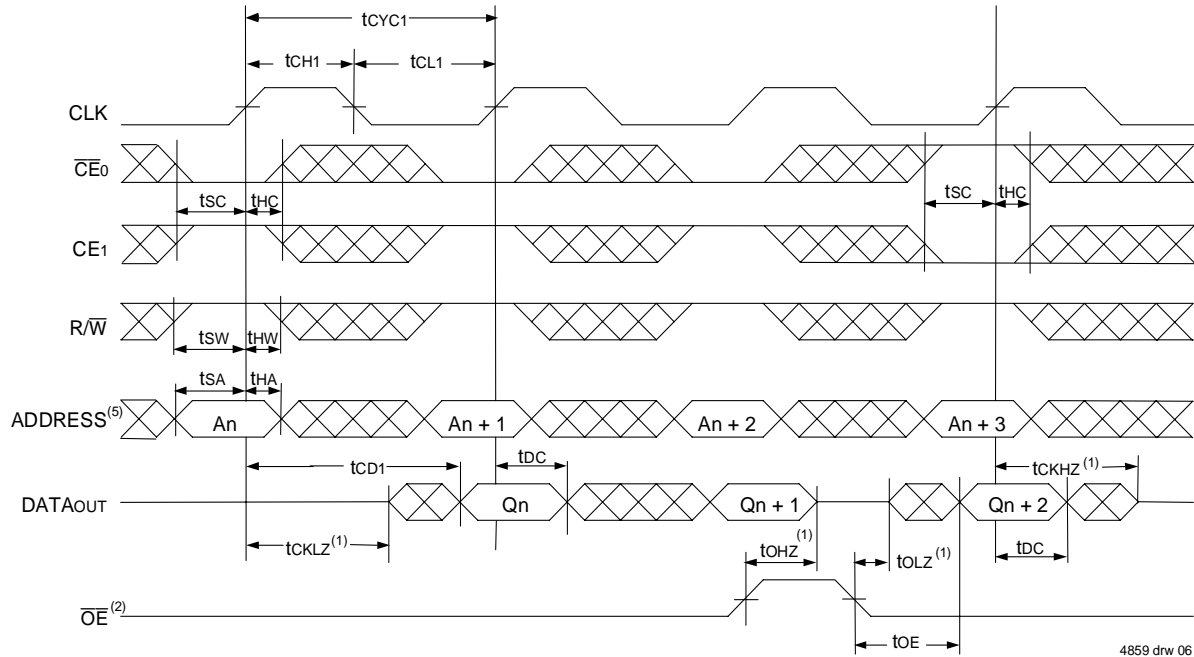

4859 drw 06

Timing Waveform of Read Cycle for Pipelined Operation ($\overline{FT}/\text{PIPE}^{\text{X}} = V_{IH}$)^(3,6)

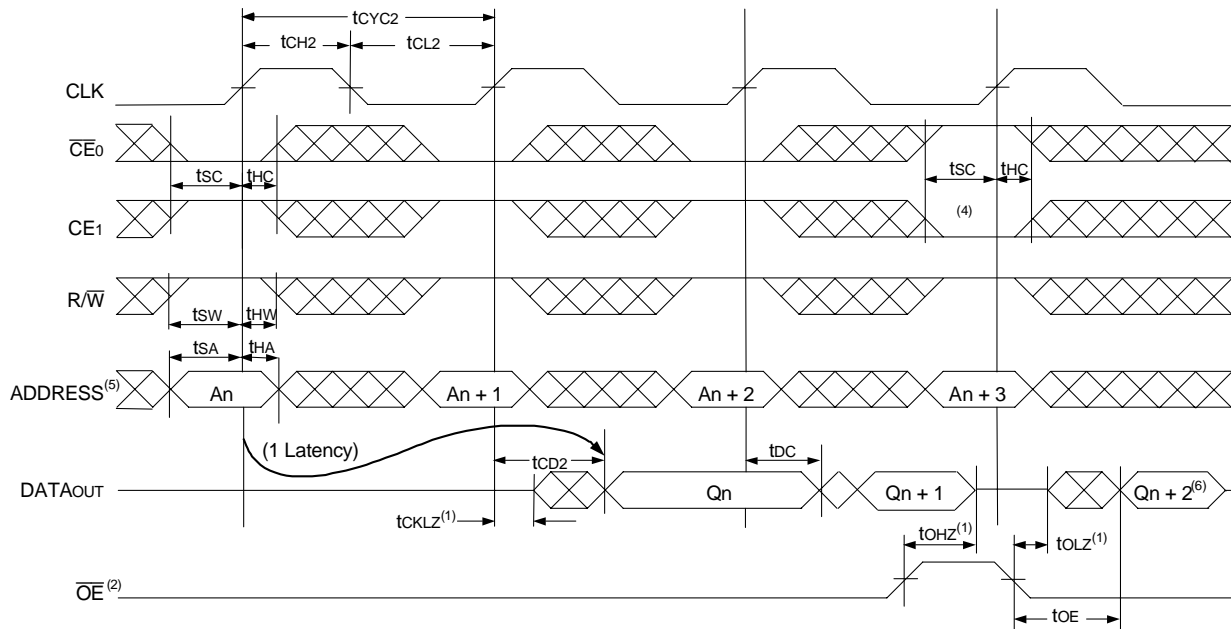

4859 drw 07

NOTES:

1. Transition is measured 0mV from Low or High-impedance voltage with the Output Test Load (Figure 2).
2. \overline{OE} is asynchronously controlled; all other inputs are synchronous to the rising clock edge.
3. $\text{ADS} = V_{IL}$, CNTEN and $\text{CNTRST} = V_{IH}$.
4. The output is disabled (High-Impedance state) by $\overline{CE}_0 = V_{IH}$ or $\text{CE}_1 = V_{IL}$ following the next rising edge of the clock. Refer to Truth Table 1.
5. Addresses do not have to be accessed sequentially since $\text{ADS} = V_{IL}$ constantly loads the address on the rising edge of the CLK; numbers are for reference use only.
6. 'X' here denotes Left or Right port. The diagram is with respect to that port.

Timing Waveform of a Bank Select Pipelined Read^(1,2)

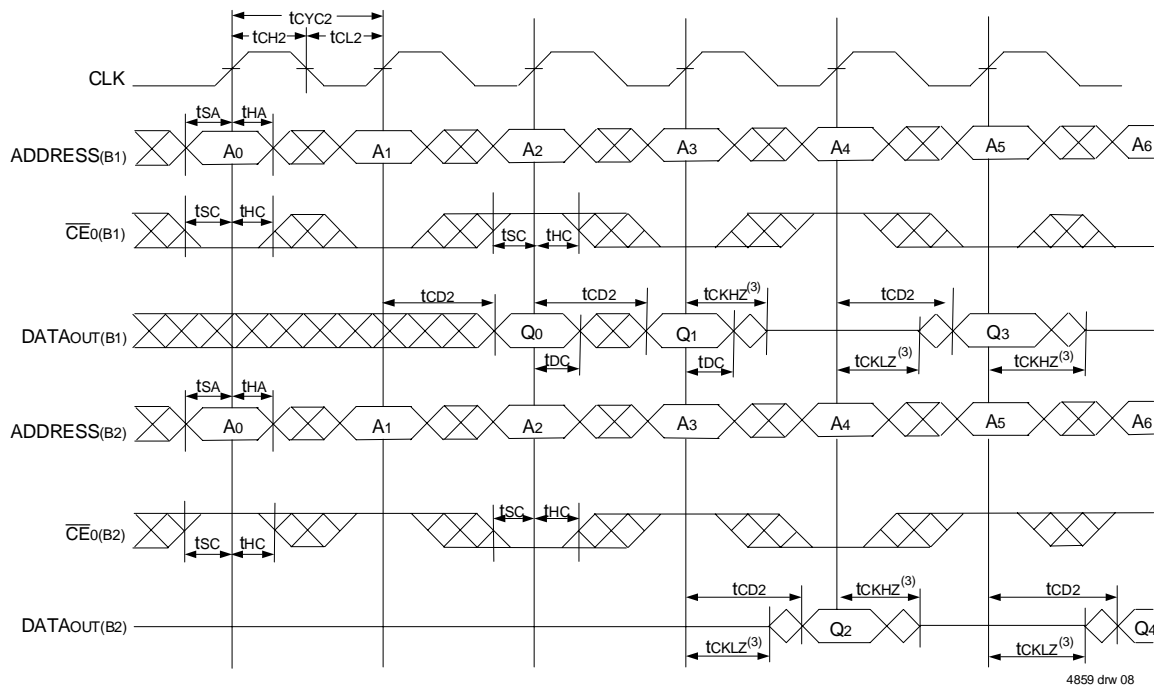

Timing Waveform with Port-to-Port Flow-Through Read^(4,5,7)

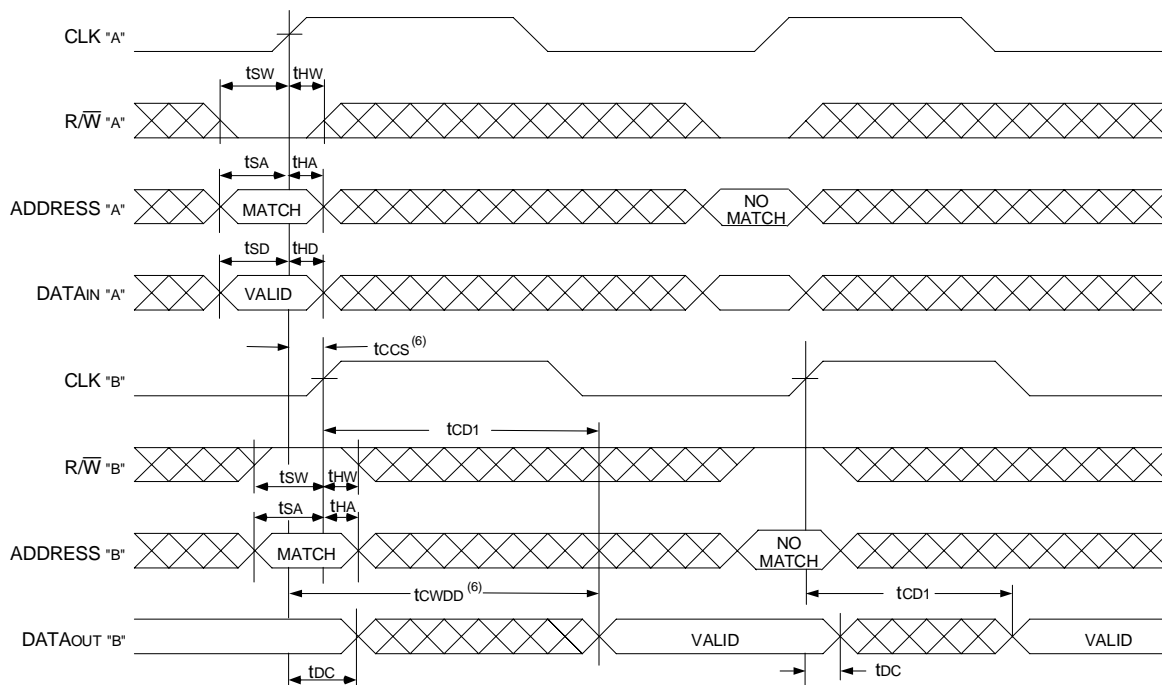

NOTES:

1. B1 Represents Bank #1; B2 Represents Bank #2. Each Bank consists of one IDT70V9199/099 for this waveform, and are setup for depth expansion in this example. ADDRESS(B1) = ADDRESS(B2) in this situation.
2. \overline{OE} and $\overline{ADS} = V_{IL}$; $CE_{1(B1)}$, $CE_{1(B2)}$, $R\overline{W}$, \overline{CNTEN} , and $\overline{CNTRST} = V_{IH}$.
3. Transition is measured 0mV from Low or High-impedance voltage with the Output Test Load (Figure 2).
4. \overline{CE}_0 and $\overline{ADS} = V_{IL}$; CE_1 , \overline{CNTEN} , and $\overline{CNTRST} = V_{IH}$.
5. $\overline{OE} = V_{IL}$ for the Right Port, which is being read from. $\overline{OE} = V_{IH}$ for the Left Port, which is being written to.
6. If $t_{CCS} \leq$ maximum specified, then data from right port READ is not valid until the maximum specified for t_{CWD} . If $t_{CCS} >$ maximum specified, then data from right port READ is not valid until $t_{CCS} + t_{CD1}$. t_{CWD} does not apply in this case.
7. All timing is the same for both Left and Right ports. Port "A" may be either Left or Right port. Port "B" is the opposite from Port "A".

Timing Waveform of Pipelined Read-to-Write-to-Read ($\overline{OE} = V_{IL}$)⁽³⁾

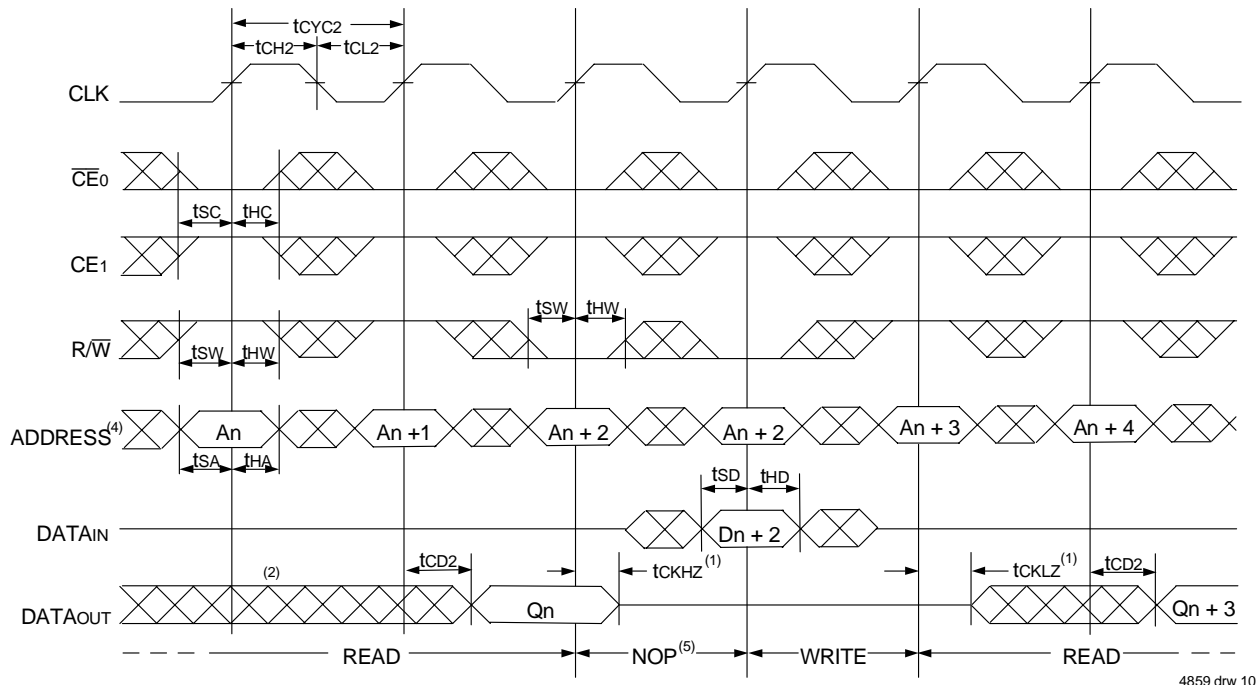

Timing Waveform of Pipelined Read-to-Write-to-Read (\overline{OE} Controlled)⁽³⁾

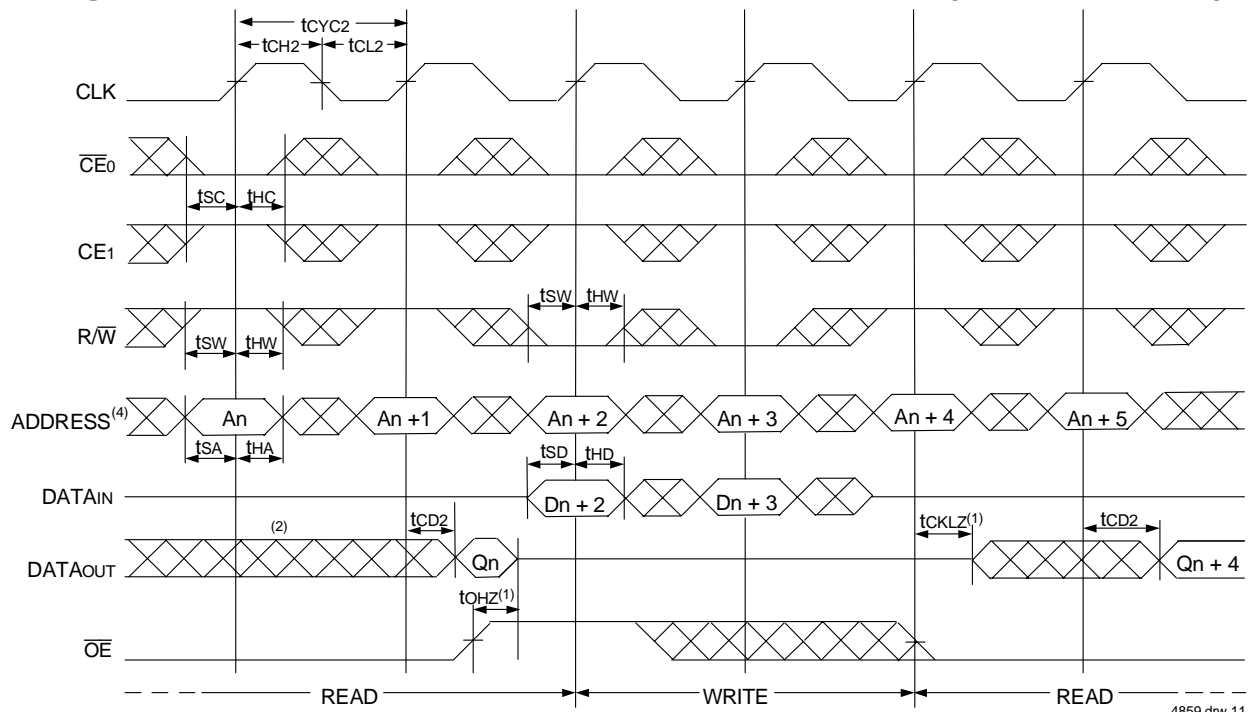

NOTES:

1. Transition is measured 0mV from Low or High-impedance voltage with the Output Test Load (Figure 2).
2. Output state (High, Low, or High-impedance) is determined by the previous cycle control signals.
3. $\overline{CE0}$ and $\overline{ADS} = V_{IL}$; $\overline{CE1}$, \overline{CNTEN} , and $\overline{CNTRST} = V_{IH}$. "NOP" is "No Operation".
4. Addresses do not have to be accessed sequentially since $\overline{ADS} = V_{IL}$ constantly loads the address on the rising edge of the CLK; numbers are for reference use only.
5. "NOP" is "No Operation." Data in memory at the selected address may be corrupted and should be re-written to guarantee data integrity.

Timing Waveform of Flow-Through Read-to-Write-to-Read ($\overline{OE} = V_{IL}$)⁽³⁾

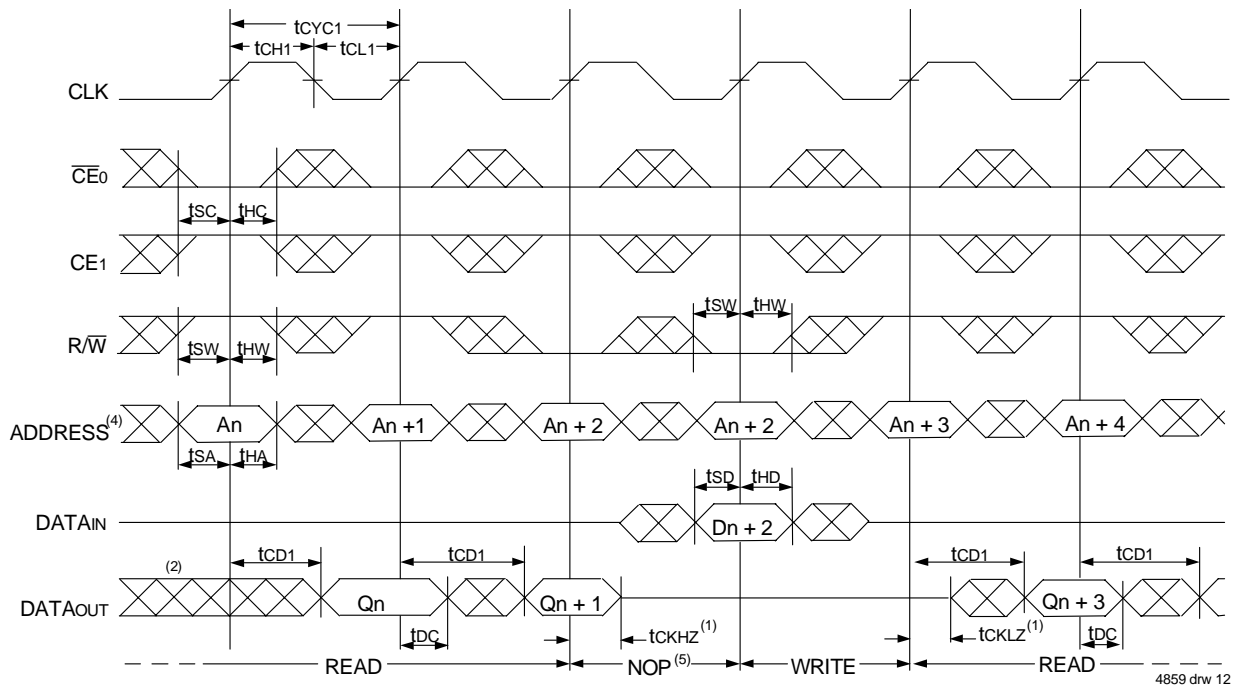

Timing Waveform of Flow-Through Read-to-Write-to-Read (\overline{OE} Controlled)⁽³⁾

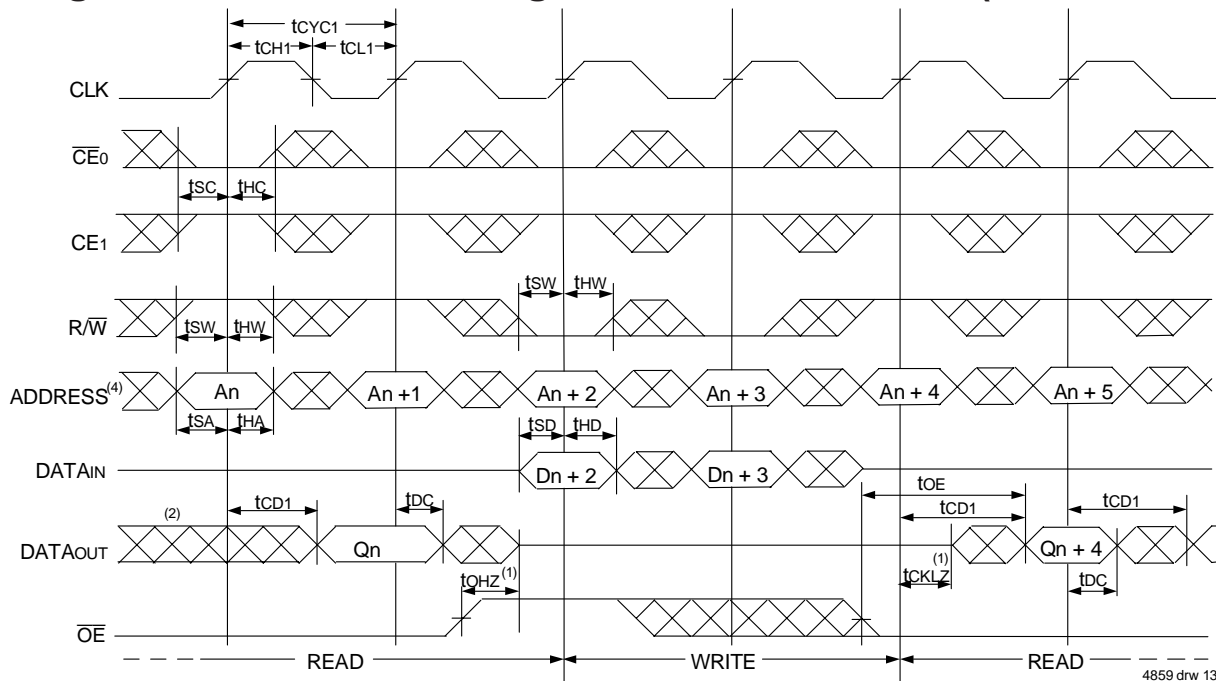

NOTES:

1. Transition is measured 0mV from Low or High-impedance voltage with the Output Test Load (Figure 2).
2. Output state (High, Low, or High-impedance) is determined by the previous cycle control signals.
3. $\overline{CE0}$ and $\overline{ADS} = V_{IL}$; $\overline{CE1}$, \overline{CNTEN} , and $\overline{CNTRST} = V_{IH}$. "NOP" is "No Operation".
4. Addresses do not have to be accessed sequentially since $\overline{ADS} = V_{IL}$ constantly loads the address on the rising edge of the CLK; numbers are for reference use only.
5. "NOP" is "No Operation." Data in memory at the selected address may be corrupted and should be re-written to guarantee data integrity.

Timing Waveform of Pipelined Read with Address Counter Advance⁽¹⁾

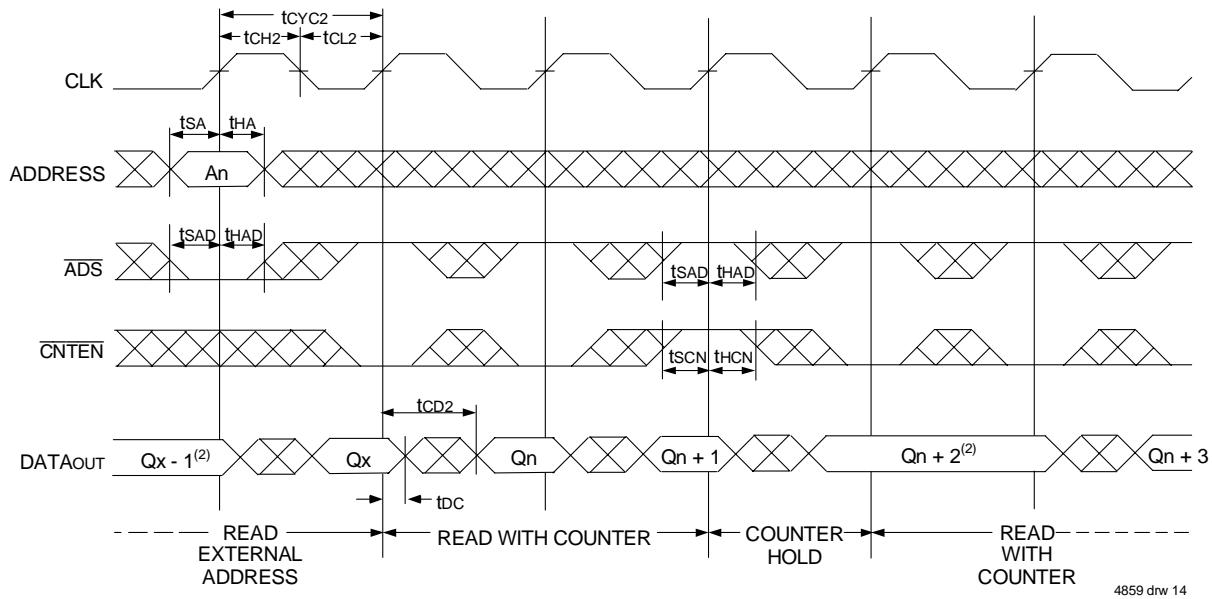

Timing Waveform of Flow-Through Read with Address Counter Advance⁽¹⁾

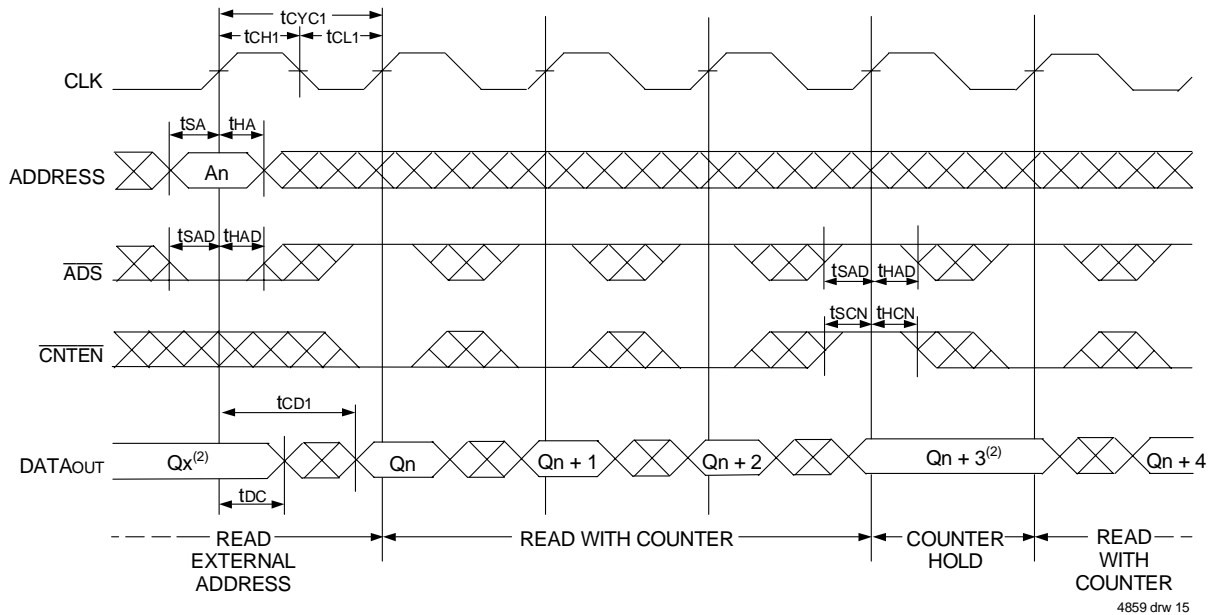

NOTES:

1. $\overline{CE0}$ and $\overline{OE} = V_{IL}$; $CE1$, $R\overline{W}$, and $\overline{CNRST} = V_{IH}$.
2. If there is no address change via $\overline{ADS} = V_{IL}$ (loading a new address) or $\overline{CNTEN} = V_{IL}$ (advancing the address), i.e. $\overline{ADS} = V_{IH}$ and $\overline{CNTEN} = V_{IH}$, then the data output remains constant for subsequent clocks.

Timing Waveform of Write with Address Counter Advance (Flow-Through or Pipelined Outputs)⁽¹⁾

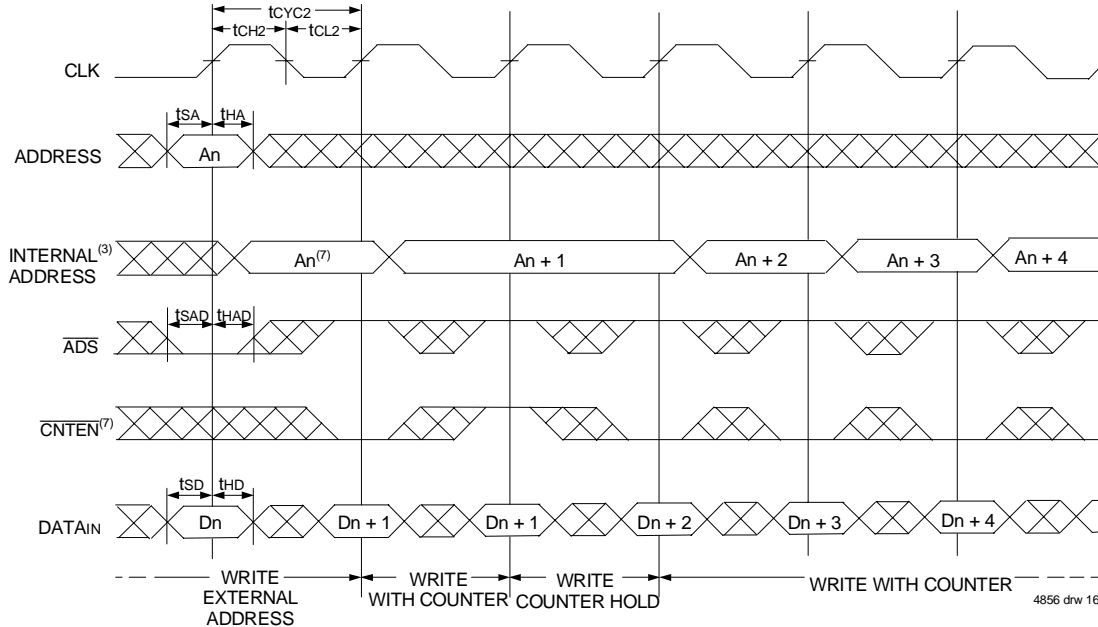

Timing Waveform of Counter Reset (Pipelined Outputs)⁽²⁾

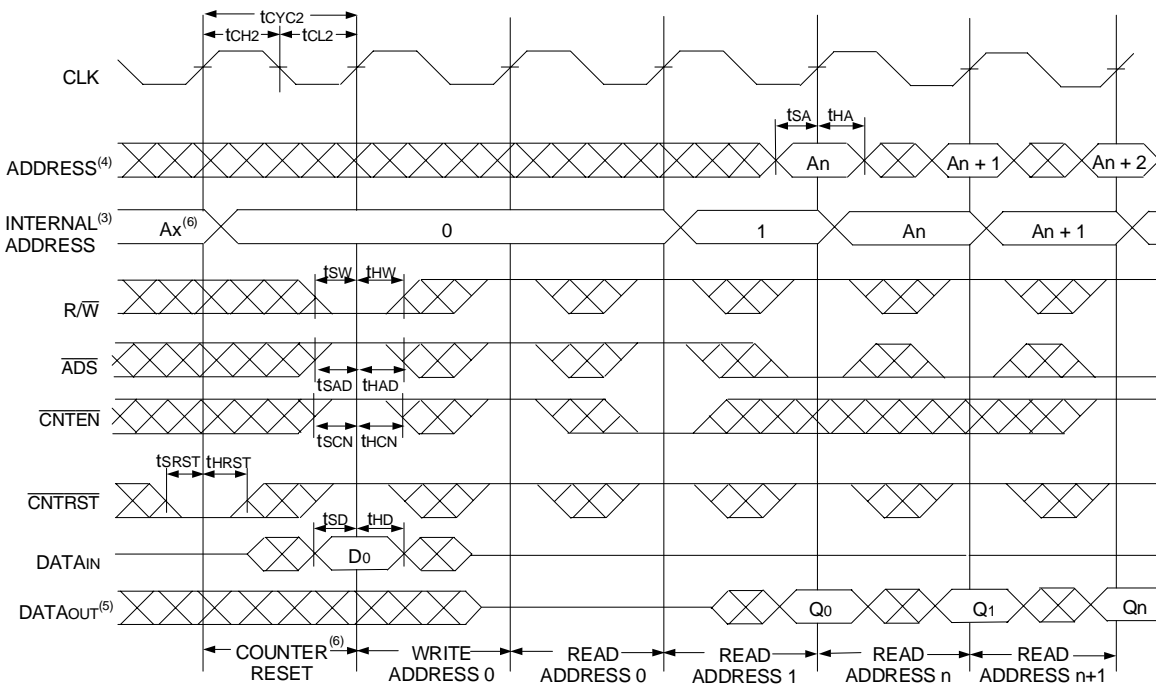

NOTES:

- \overline{CE}_0 and $\overline{R/W} = V_{IL}$; CE_1 and $\overline{CNTRST} = V_{IH}$.
- $\overline{CE}_0 = V_{IL}$; $CE_1 = V_{IH}$.
- The "Internal Address" is equal to the "External Address" when $\overline{ADS} = V_{IL}$ and equals the counter output when $\overline{ADS} = V_{IH}$.
- Addresses do not have to be accessed sequentially since $\overline{ADS} = V_{IL}$ constantly loads the address on the rising edge of the CLK; numbers are for reference use only.
- Output state (High, Low, or High-impedance) is determined by the previous cycle control signals.
- No dead cycle exists during counter reset. A READ or WRITE cycle may be coincidental with the counter reset cycle. ADDR₀ will be accessed. Extra cycles are shown here simply for clarification.
- $\overline{CNTEN} = V_{IL}$ advances Internal Address from 'An' to 'An + 1'. The transition shown indicates the time required for the counter to advance. The 'An + 1' Address is written to during this cycle.

Functional Description

The IDT70V9199/099 provides a true synchronous Dual-Port Static RAM interface. Registered inputs provide minimal set-up and hold times on address, data, and all critical control inputs. All internal registers are clocked on the rising edge of the clock signal, however, the self-timed internal write pulse is independent of the LOW to HIGH transition of the clock signal.

An asynchronous output enable is provided to ease asynchronous bus interfacing. Counter enable inputs are also provided to staff the operation of the address counters for fast interleaved memory applications.

$\overline{CE}_0 = V_{IL}$ and $CE_1 = V_{IH}$ for one clock cycle will power down the internal circuitry to reduce static power consumption. Multiple chip enables allow easier banking of multiple IDT70V9199/099's for depth expansion configurations. When the Pipelined output mode is enabled, two cycles are required with $\overline{CE}_0 = V_{IH}$ or $CE_1 = V_{IL}$ to re-activate the outputs.

Depth and Width Expansion

The IDT70V9199/099 features dual chip enables (refer to Truth Table I) in order to facilitate rapid and simple depth expansion with no requirements for external logic. Figure 4 illustrates how to control the various chip enables in order to expand two devices in depth.

The IDT70V9199/099 can also be used in applications requiring expanded width, as indicated in Figure 4. Since the banks are allocated at the discretion of the user, the external controller can be set up to drive the input signals for the various devices as required to allow for 18/16-bit or wider applications.

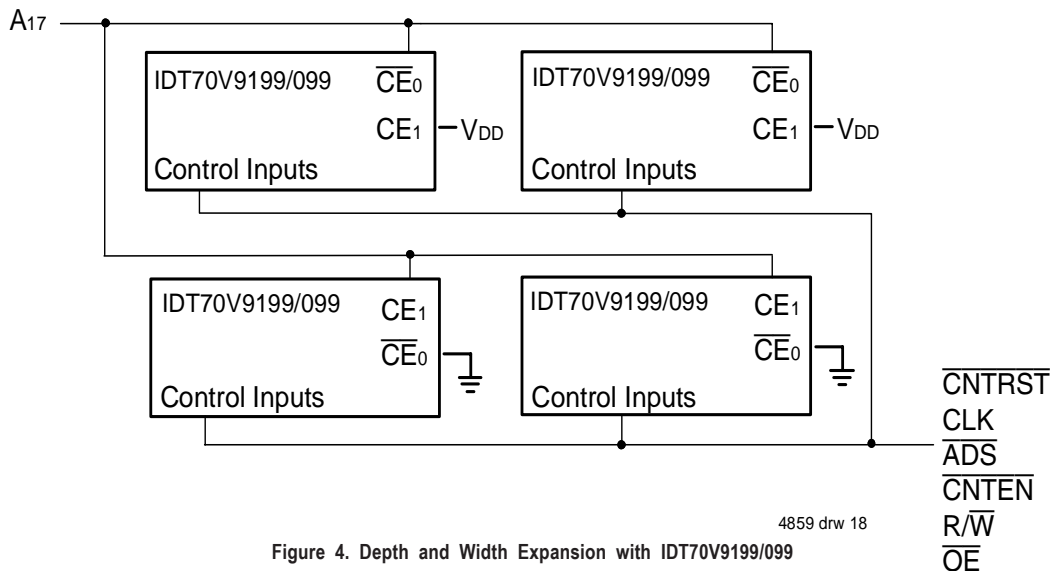

Datasheet Document History

9/30/99:	Initial Public Release
11/12/99:	Replaced IDT logo
01/10/01:	Page 3 Changed information in Truth Table II
	Page 4 Increased storage temperature parameters Clarified TA parameter
	Page 5 DC Electrical parameters—changed wording from "open" to "disabled" Changed $\pm 200\text{mV}$ to 0mV in notes Removed Preliminary status
	04/09/03:
	Consolidate multiple devices into one datasheet Changed naming conventions from V_{CC} to V_{DD} and from GND to V_{SS} Page 2 & 3 Added date revision to pin configurations Page 5 Added junction temperature to Absolute Maximum Ratings Table Added Ambient Temperature footnote Page 1, 6 & 16 Added 6ns speed grade Page 6 Added updated DC power numbers to the DC Electrical Characteristics Table Page 8 Added 6ns speed AC timing numbers and changed t_{OE} to be equal to t_{OD2} in the AC Electrical Characteristics Table Page 16 Added IDT Clock Solution Table



CORPORATE HEADQUARTERS

2975 Stender Way
Santa Clara, CA 95054

for SALES:

800-345-7015 or 408-727-6116
fax: 408-492-8674
www.idt.com

for Tech Support:

831-754-4613
DualPortHelp@idt.com