

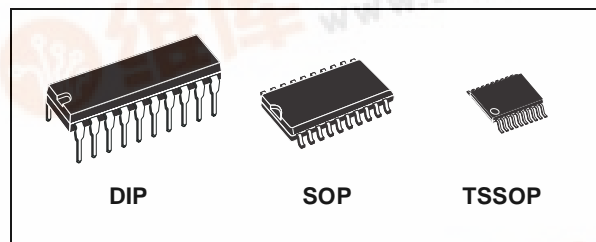

M74HC299

8 BIT PIPO SHIFT REGISTER WITH ASYNCHRONOUS CLEAR

- HIGH SPEED :
 $f_{MAX} = 80\text{MHz}$ (TYP.) at $V_{CC} = 6\text{V}$
- LOW POWER DISSIPATION:
 $I_{CC} = 4\mu\text{A}$ (MAX.) at $T_A = 25^\circ\text{C}$
- HIGH NOISE IMMUNITY:
 $V_{NIH} = V_{NIL} = 28\% V_{CC}$ (MIN.)
- SYMMETRICAL OUTPUT IMPEDANCE:
 $|I_{OH}| = |I_{OL}| = 6\text{mA}$ (MIN) FOR QA' TO QH'
 $|I_{OH}| = |I_{OL}| = 4\text{mA}$ (MIN) FOR QA TO QH
- BALANCED PROPAGATION DELAYS:
 $t_{PLH} \cong t_{PHL}$
- WIDE OPERATING VOLTAGE RANGE:
 V_{CC} (OPR) = 2V to 6V
- PIN AND FUNCTION COMPATIBLE WITH
 74 SERIES 299



ORDER CODES

PACKAGE	TUBE	T & R
DIP	M74HC299B1R	
SOP	M74HC299M1R	M74HC299RM13TR
TSSOP		M74HC299TTR

DESCRIPTION

The M74HC299 is an high speed CMOS 8 BIT PIPO SHIFT REGISTER (3-STATE) fabricated with silicon gate C²MOS technology. This device has four modes (HOLD, SHIFT LEFT, SHIFT RIGHT and LOAD DATA). Each mode is chosen by two function select inputs ($\overline{S_0}$, $\overline{S_1}$). When one or both enable inputs, ($\overline{G_1}$, $\overline{G_2}$) are

high, the eight input/output terminals are in the high impedance state; however sequential operation or clearing of the register is not affected. Clear function on the M74HC299 is asynchronous to CLOCK. All inputs are equipped with protection circuits against static discharge and transient excess voltage.

PIN CONNECTION AND IEC LOGIC SYMBOLS

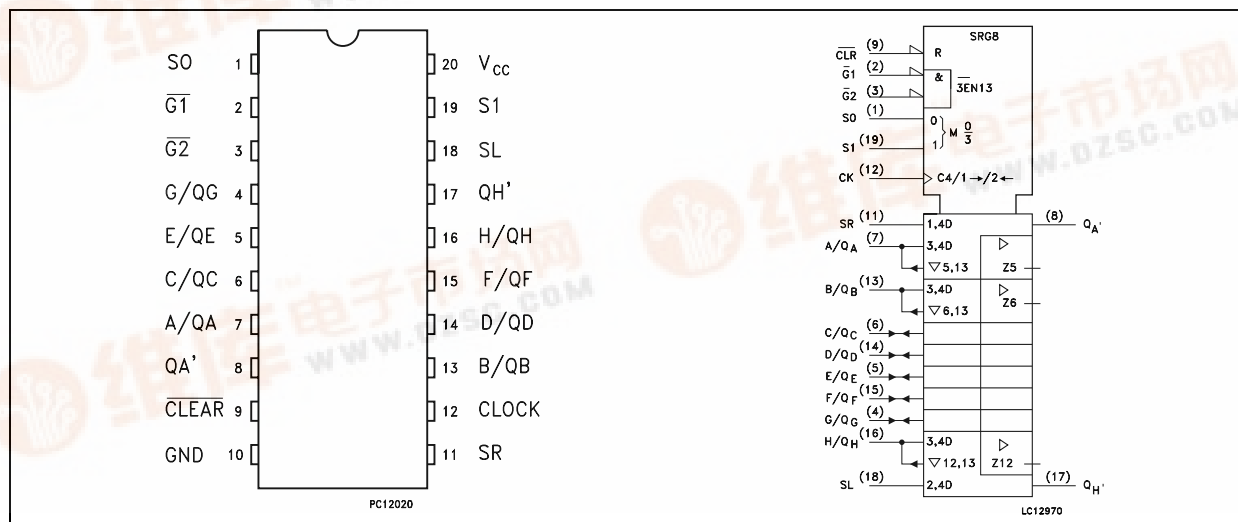

M74HC299

IINPUT AND OUTPUT EQUIVALENT CIRCUIT

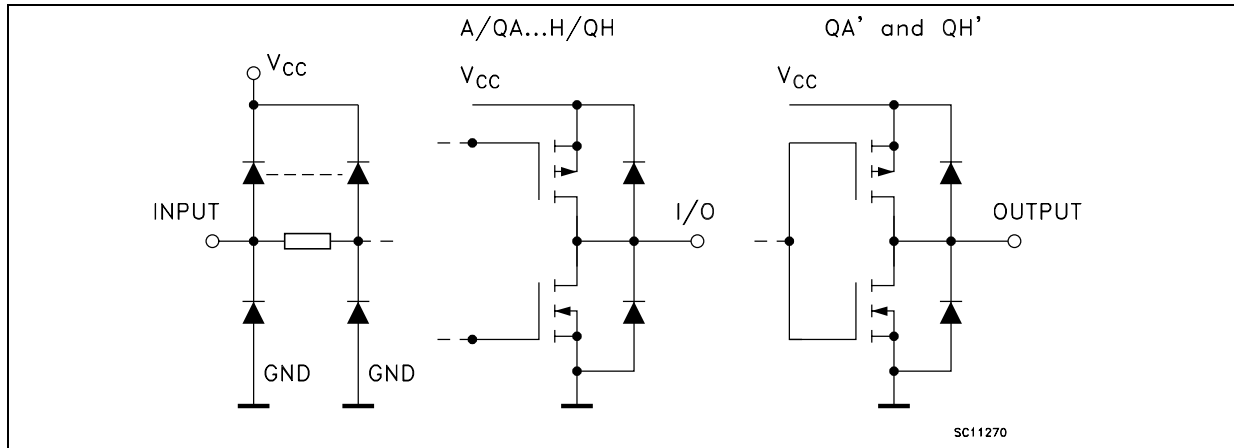

PIN DESCRIPTION

PIN No	SYMBOL	NAME AND FUNCTION
1, 19	S0, S1	Mode Select Inputs
2, 3	G1, G2	3-State Output Enable Inputs (Active LOW)
7, 13, 6, 14, 5, 15, 4, 16	A/QA to H/QH	Parallel Data Inputs or 3-State Parallel Outputs (Bus Driver)
8, 17	QA' to QH'	Serial Outputs (Standard Output)
9	CLEAR	Asynchronous Master Reset Input (Active LOW)
11	SR	Serial Data Shift Right Input
12	CLOCK	Clock Input (LOW to HIGH, Edge-triggered)
18	SL	Serial Data Shift Left Input
10	GND	Ground (0V)
20	V _{CC}	Positive Supply Voltage

TRUTH TABLE

MODE	INPUTS						INPUTS/OUTPUTS				OUTPUTS	
	CLEAR	FUNCTION SELECTED		OUTPUT CONTROL		CLOCK	SERIAL		A/QA	H/QH	QA'	QH'
		S1	S0	G1*	G2*		SL	SR				
Z	L	H	H	X	X	X	X	X	Z	Z	L	L
CLEAR	L	L	X	L	L	X	X	X	L	L	L	L
	L	X	L	L	L	X	X	X	L	L	L	L
HOLD	H	L	L	L	L	X	X	X	QA0	QH0	QA0	QH0
SHIFT RIGHT	H	L	H	L	L	┌	X	H	H	QGn	H	QGn
	H	L	H	L	L	└	X	L	L	QGn	L	QGn
SHIFT LEFT	H	H	L	L	L	┌	H	X	QBn	H	QBn	H
	H	H	L	L	L	└	L	X	QBn	L	QBn	L
LOAD	H	H	H	X	X	┌	X	X	a	h	a	h

* When one or both output controls are high, the eight input/output terminals are in the high impedance state: however sequential operation or clearing of the register is not affected.

Z : High Impedance

Qn0 : The level of An before the indicated steady state input conditions were established.

Qnn : The level of Qn before the most recent active transition indicated by \lrcorner OR \llcorner

a, h : The level of the steady state inputs A, H, respectively.

X : Don't Care

LOGIC DIAGRAM

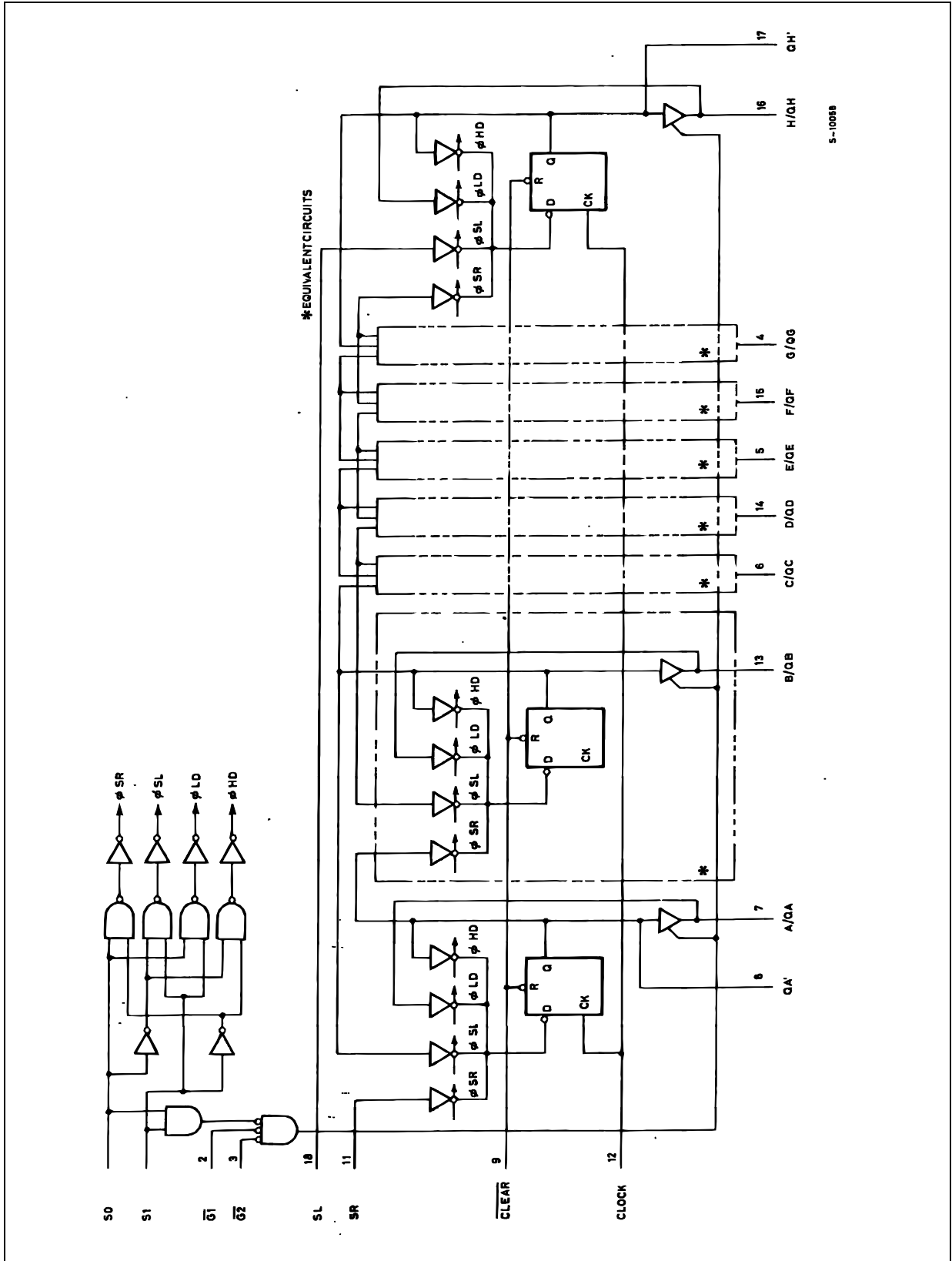

M74HC299

TIMING CHART

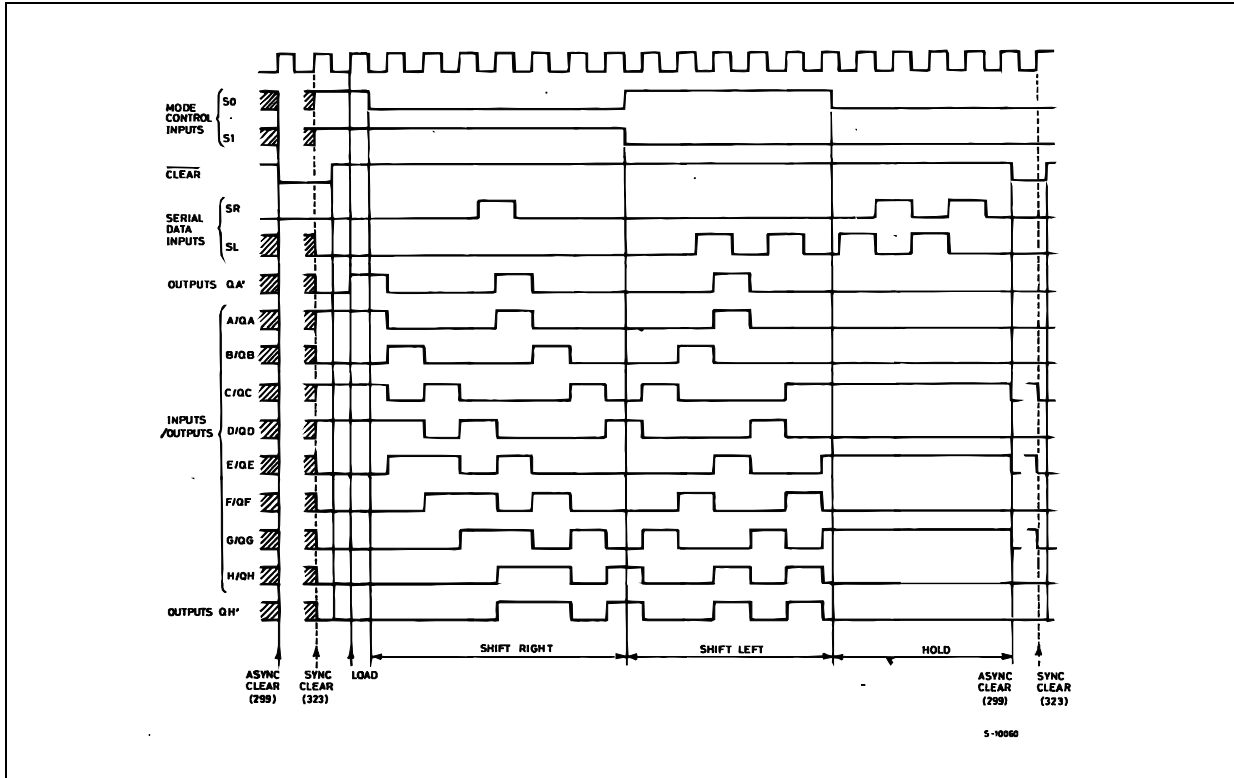

ABSOLUTE MAXIMUM RATINGS

Symbol	Parameter	Value	Unit
V_{CC}	Supply Voltage	-0.5 to +7	V
V_I	DC Input Voltage	-0.5 to $V_{CC} + 0.5$	V
V_O	DC Output Voltage	-0.5 to $V_{CC} + 0.5$	V
I_{IK}	DC Input Diode Current	± 20	mA
I_{OK}	DC Output Diode Current	± 20	mA
I_O	DC Output Source Sink Current Per Output Pin (QA-QH)	± 35	mA
I_O	DC Output Source Sink Current Per Output Pin (QA'-QH')	± 235	mA
I_{CC} or I_{GND}	DC V_{CC} or Ground Current	± 70	mA
P_D	Power Dissipation	500(*)	mW
T_{stg}	Storage Temperature	-65 to +150	$^{\circ}C$
T_L	Lead Temperature (10 sec)	300	$^{\circ}C$

Absolute Maximum Ratings are those values beyond which damage to the device may occur. Functional operation under these conditions is not implied.

(*) 500mW at 65 $^{\circ}C$; derate to 300mW by 10mW/ $^{\circ}C$ from 65 $^{\circ}C$ to 85 $^{\circ}C$

RECOMMENDED OPERATING CONDITIONS

Symbol	Parameter	Value	Unit	
V_{CC}	Supply Voltage	2 to 6	V	
V_I	Input Voltage	0 to V_{CC}	V	
V_O	Output Voltage	0 to V_{CC}	V	
T_{op}	Operating Temperature	-55 to 125	°C	
t_r, t_f	Input Rise and Fall Time	$V_{CC} = 2.0V$	0 to 1000	ns
		$V_{CC} = 4.5V$	0 to 500	ns
		$V_{CC} = 6.0V$	0 to 400	ns

DC SPECIFICATIONS

Symbol	Parameter	Test Condition		Value						Unit	
		V_{CC} (V)		$T_A = 25^\circ C$			-40 to 85°C		-55 to 125°C		
				Min.	Typ.	Max.	Min.	Max.	Min.		Max.
V_{IH}	High Level Input Voltage	2.0		1.5			1.5		1.5		V
		4.5		3.15			3.15		3.15		
		6.0		4.2			4.2		4.2		
V_{IL}	Low Level Input Voltage	2.0				0.5		0.5		0.5	V
		4.5				1.35		1.35		1.35	
		6.0				1.8		1.8		1.8	
V_{OH}	High Level Output Voltage	2.0	$I_O = -20 \mu A$	1.9	2.0		1.9		1.9		V
		4.5	$I_O = -20 \mu A$	4.4	4.5		4.4		4.4		
		6.0	$I_O = -20 \mu A$	5.9	6.0		5.9		5.9		
	QA to QH	4.5	$I_O = -6.0 mA$	4.18	4.31		4.13		4.10		
		6.0	$I_O = -7.8 mA$	5.68	5.8		5.63		5.60		
	QA' to QH'	4.5	$I_O = -4.0 mA$	4.18	4.31		4.13		4.10		
6.0		$I_O = -5.2 mA$	5.68	5.8		5.63		5.60			
V_{OL}	Low Level Output Voltage	2.0	$I_O = 20 \mu A$		0.0	0.1		0.1		0.1	V
		4.5	$I_O = 20 \mu A$		0.0	0.1		0.1		0.1	
		6.0	$I_O = 20 \mu A$		0.0	0.1		0.1		0.1	
	QA to QH	4.5	$I_O = 6.0 mA$		0.17	0.26		0.33		0.40	
		6.0	$I_O = 7.8 mA$		0.18	0.26		0.33		0.40	
	QA' to QH'	4.5	$I_O = 4.0 mA$		0.17	0.26		0.33		0.40	
6.0		$I_O = 5.2 mA$		0.18	0.26		0.33		0.40		
I_I	Input Leakage Current	6.0	$V_I = V_{CC}$ or GND			± 0.1		± 1		± 1	μA
I_{OZ}	High Impedance Output Leakage Current	6.0	$V_I = V_{IH}$ or V_{IL} $V_O = V_{CC}$ or GND			± 0.5		± 5		± 10	μA
I_{CC}	Quiescent Supply Current	6.0	$V_I = V_{CC}$ or GND			4		40		80	μA

M74HC299

AC ELECTRICAL CHARACTERISTICS ($C_L = 50 \text{ pF}$, Input $t_r = t_f = 6 \text{ ns}$)

Symbol	Parameter	Test Condition		Value						Unit		
		V_{CC} (V)		$T_A = 25^\circ\text{C}$			$-40 \text{ to } 85^\circ\text{C}$		$-55 \text{ to } 125^\circ\text{C}$			
				Min.	Typ.	Max.	Min.	Max.	Min.		Max.	
t_{TLH} t_{THL}	Output Transition Time (QA, QH)	2.0	50		25	60		75		90	ns	
		4.5			7	12		15		18		
		6.0			6	10		13		15		
t_{TLH} t_{THL}	Output Transition Time (QA', QH')	2.0	50		30	75		95		110	ns	
		4.5			8	15		19		22		
		6.0			7	13		16		19		
t_{PLH} t_{PHL}	Propagation Delay Time (CLOCK - QA', QH')	2.0	50		85	170		215		255	ns	
		4.5			23	34		43		51		
		6.0			18	29		37		43		
t_{PHL}	Propagation Delay Time (CLEAR - QA', QH')	2.0	50		85	175		220		265	ns	
		4.5			24	35		44		53		
		6.0			18	30		37		45		
t_{PLH} t_{PHL}	Propagation Delay Time (CLOCK - QA, QH)	2.0	50		80	160		200		240	ns	
		4.5			21	32		40		48		
		6.0			17	27		34		41		
		2.0	150		100	200		250		300	ns	
		4.5			26	40		50		60		
		6.0			21	34		43		51		
t_{PZL} t_{PZH}	High Impedance Output Enable Time	2.0	50	$R_L = 1 \text{ K}\Omega$		60	130		165		195	ns
		4.5				17	26		33		39	
		6.0				13	22		28		33	
		2.0	150	$R_L = 1 \text{ K}\Omega$		78	170		15		255	ns
		4.5				23	34		43		51	
		6.0				17	29		37		43	
t_{PLZ} t_{PHZ}	High Impedance Output Disable Time	2.0	50	$R_L = 1 \text{ K}\Omega$		54	150		190		225	ns
		4.5				19	30		38		45	
		6.0				16	26		32		38	
f_{MAX}	Maximum Clock Frequency	2.0	50		6	12		4.8		4	MHz	
		4.5			30	58		24		20		
		6.0			35	80		28		24		
$t_{W(L)}$ $t_{W(H)}$	Minimum Pulse Width (CLOCK)	2.0	50			75		95		110	ns	
		4.5				15		19		22		
		6.0				13		16		19		
$t_{W(L)}$	Minimum Pulse Width (CLEAR)	2.0	50			75		95		110	ns	
		4.5				15		19		22		
		6.0				13		16		19		
t_s	Minimum Set-up Time (S0, S1) (SL, SR, A, H)	2.0	50			100		125		150	ns	
		4.5				20		25		30		
		6.0				17		21		26		
t_h	Minimum Hold Time (S0, S1) (SL, SR, A, H)	2.0	50			0		0		0	ns	
		4.5				0		0		0		
		6.0				0		0		0		
t_{REM}	Minimum Removal Time (CLEAR)	2.0	50			50		65		75	ns	
		4.5				10		13		15		
		6.0				9		11		13		

CAPACITIVE CHARACTERISTICS

Symbol	Parameter	Test Condition		Value						Unit	
		V _{CC} (V)		T _A = 25°C			-40 to 85°C		-55 to 125°C		
				Min.	Typ.	Max.	Min.	Max.	Min.		Max.
C _{IN}	Input Capacitance	5.0			5	10		10		10	pF
C _{PD}	Power Dissipation Capacitance (note 1)	5.0			170						pF

1) C_{PD} is defined as the value of the IC's internal equivalent capacitance which is calculated from the operating current consumption without load. (Refer to Test Circuit). Average operating current can be obtained by the following equation. $I_{CC(opr)} = C_{PD} \times V_{CC} \times f_{IN} + I_{CC}$

TEST CIRCUIT

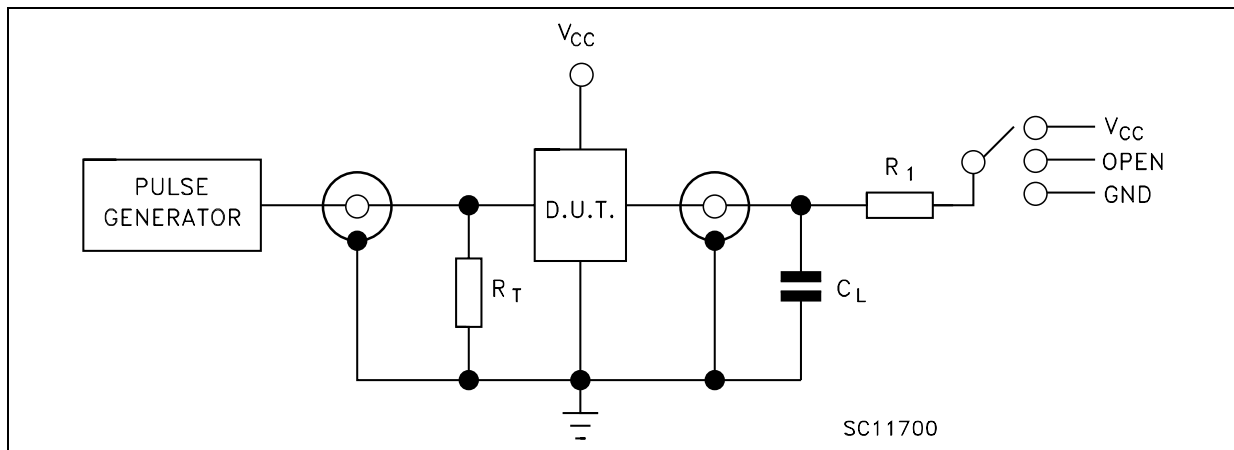

TEST	SWITCH
t _{PLH} , t _{PHL}	Open
t _{PZL} , t _{PLZ}	V _{CC}
t _{PZH} , t _{PHZ}	GND

C_L = 50pF/150pF or equivalent (includes jig and probe capacitance)

R₁ = 1KΩ or equivalent

R_T = Z_{OUT} of pulse generator (typically 50Ω)

WAVEFORM 1: PROPAGATION DELAY TIMES, MINIMUM PULSE WIDTH (f=1MHz; 50% duty cycle)

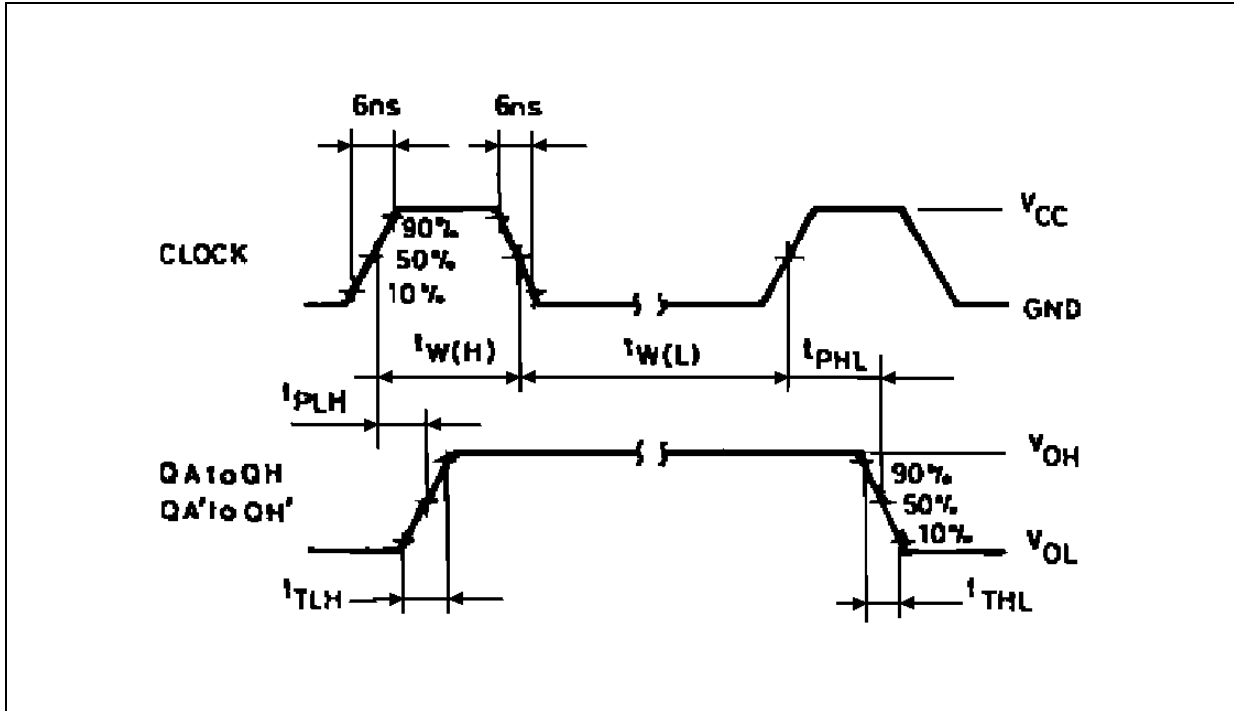

WAVEFORM 2 : SETUP AND HOLD TIMES (f=1MHz; 50% duty cycle)

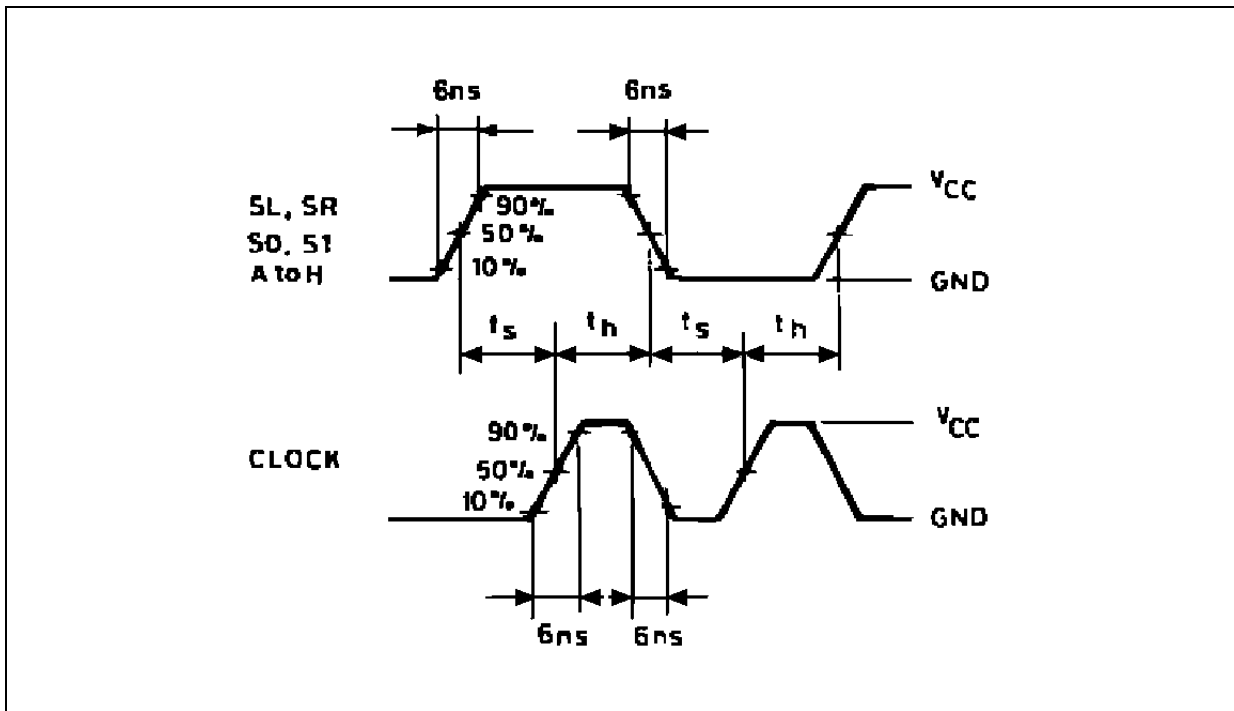

WAVEFORM 3 : PROPAGATION DELAY AND REMOVAL TIME, MINIMUM PULSE WIDTH
(f=1MHz; 50% duty cycle)

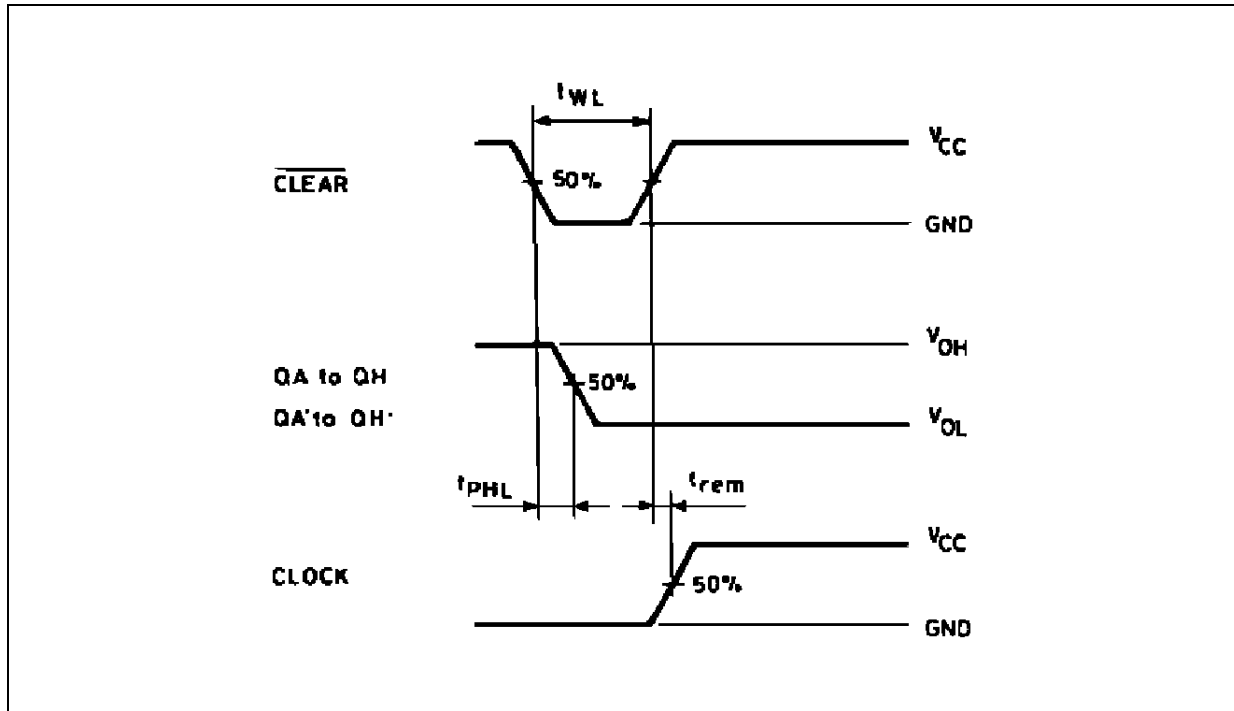

WAVEFORM 4: OUTPUT ENABLE AND DISABLE TIMES (f=1MHz; 50% duty cycle)

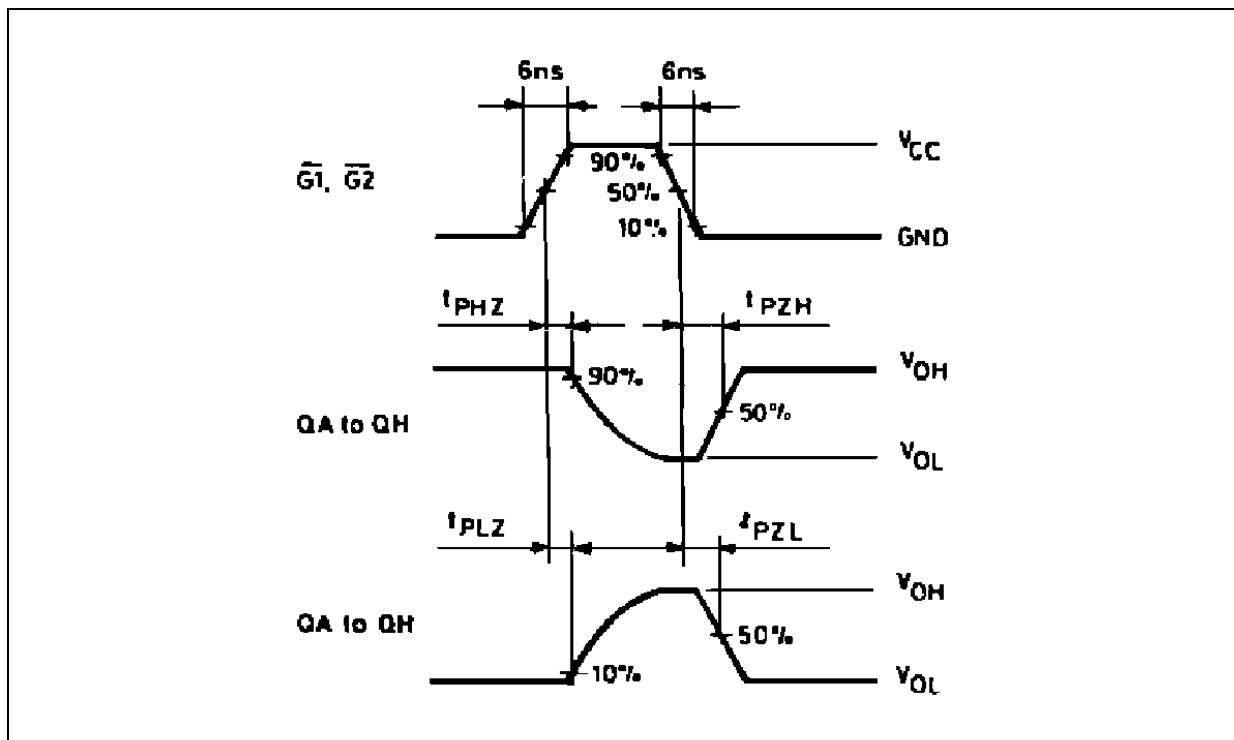

Plastic DIP-20 (0.25) MECHANICAL DATA

DIM.	mm.			inch		
	MIN.	TYP.	MAX.	MIN.	TYP.	MAX.
a1	0.254			0.010		
B	1.39		1.65	0.055		0.065
b		0.45			0.018	
b1		0.25			0.010	
D			25.4			1.000
E		8.5			0.335	
e		2.54			0.100	
e3		22.86			0.900	
F			7.1			0.280
l			3.93			0.155
L		3.3			0.130	
Z			1.34			0.053

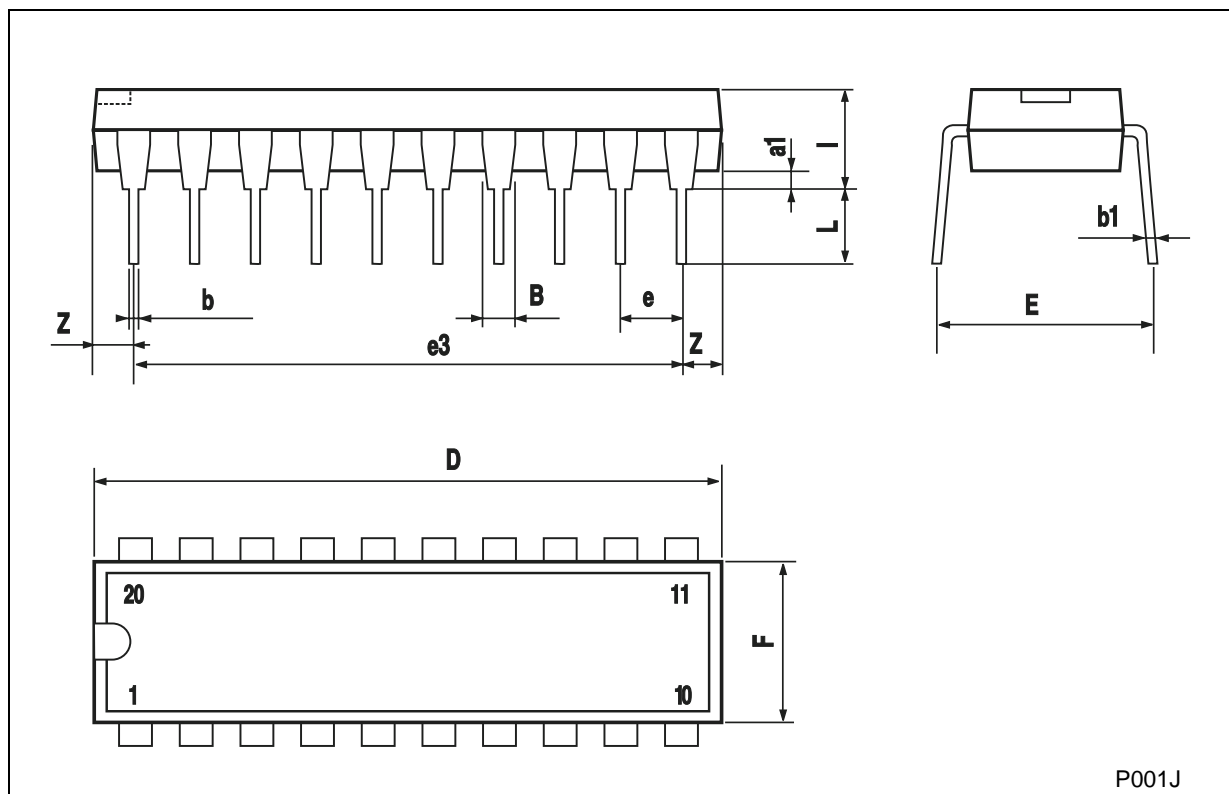

P001J

SO-20 MECHANICAL DATA

DIM.	mm.			inch		
	MIN.	TYP	MAX.	MIN.	TYP.	MAX.
A			2.65			0.104
a1	0.1		0.2	0.004		0.008
a2			2.45			0.096
b	0.35		0.49	0.014		0.019
b1	0.23		0.32	0.009		0.012
C		0.5			0.020	
c1	45° (typ.)					
D	12.60		13.00	0.496		0.512
E	10.00		10.65	0.393		0.419
e		1.27			0.050	
e3		11.43			0.450	
F	7.40		7.60	0.291		0.300
L	0.50		1.27	0.020		0.050
M			0.75			0.029
S	8° (max.)					

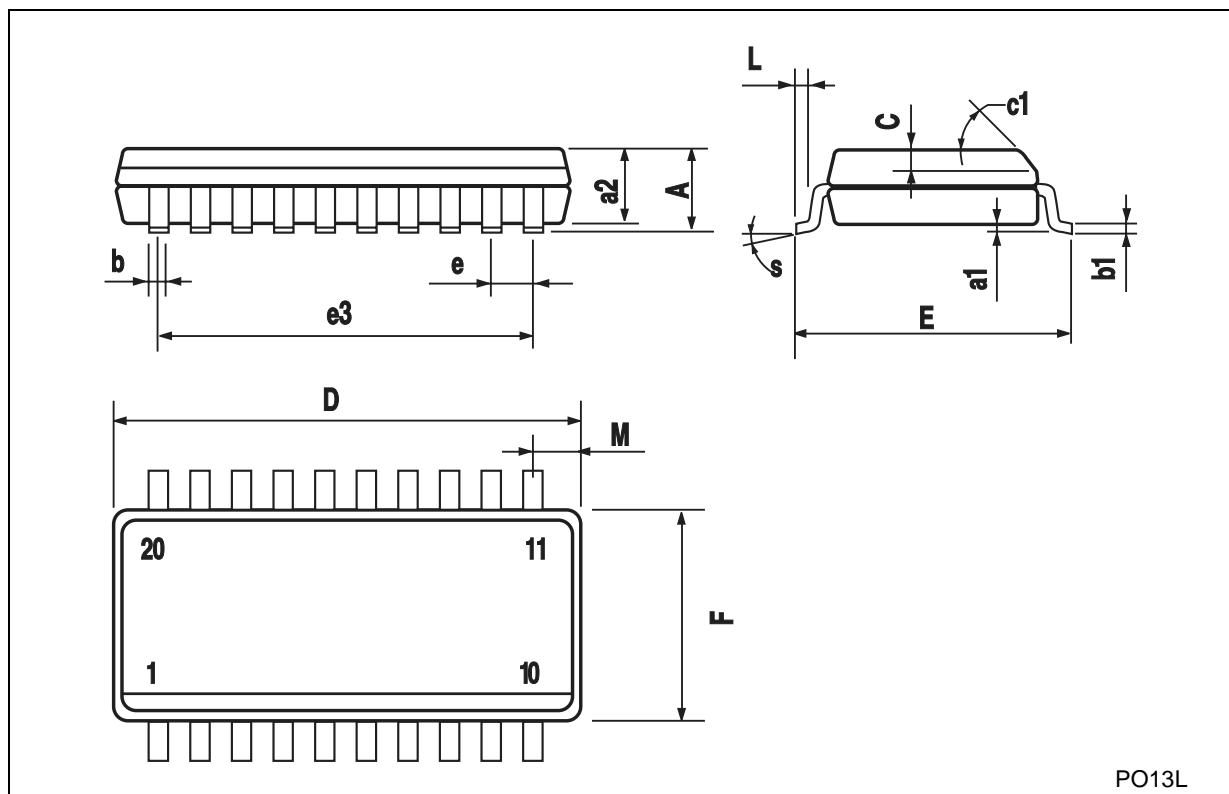

TSSOP20 MECHANICAL DATA

DIM.	mm.			inch		
	MIN.	TYP	MAX.	MIN.	TYP.	MAX.
A			1.2			0.047
A1	0.05		0.15	0.002	0.004	0.006
A2	0.8	1	1.05	0.031	0.039	0.041
b	0.19		0.30	0.007		0.012
c	0.09		0.20	0.004		0.0089
D	6.4	6.5	6.6	0.252	0.256	0.260
E	6.2	6.4	6.6	0.244	0.252	0.260
E1	4.3	4.4	4.48	0.169	0.173	0.176
e		0.65 BSC			0.0256 BSC	
K	0°		8°	0°		8°
L	0.45	0.60	0.75	0.018	0.024	0.030

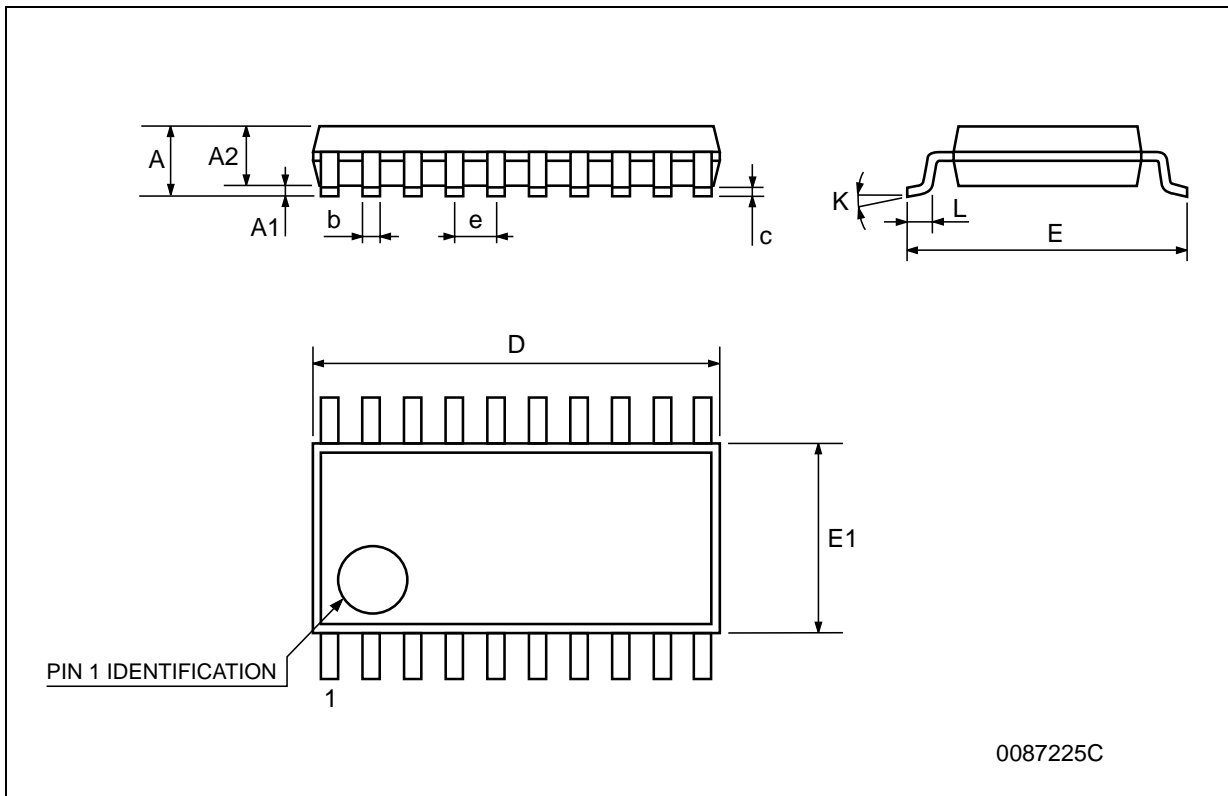

Information furnished is believed to be accurate and reliable. However, STMicroelectronics assumes no responsibility for the consequences of use of such information nor for any infringement of patents or other rights of third parties which may result from its use. No license is granted by implication or otherwise under any patent or patent rights of STMicroelectronics. Specifications mentioned in this publication are subject to change without notice. This publication supersedes and replaces all information previously supplied. STMicroelectronics products are not authorized for use as critical components in life support devices or systems without express written approval of STMicroelectronics.

© The ST logo is a registered trademark of STMicroelectronics

© 2001 STMicroelectronics - Printed in Italy - All Rights Reserved
STMicroelectronics GROUP OF COMPANIES

Australia - Brazil - China - Finland - France - Germany - Hong Kong - India - Italy - Japan - Malaysia - Malta - Morocco
Singapore - Spain - Sweden - Switzerland - United Kingdom

© <http://www.st.com>

