

April 2000

LM4121

Precision Micropower Low Dropout Voltage Reference

General Description

The LM4121 is a precision bandgap voltage reference available in a fixed 1.25V and adjustable version with up to 5 mA current source and sink capability.

This series reference operates with input voltages as low as 1.8V and up to 12V consuming 160 μA (Typ.) supply current. In power down mode, device current drops to less than 2 μA .

The LM4121 comes in two grades A and Standard. The best grade devices (A) have an initial accuracy of 0.2%, while the standard have an initial accuracy of 0.5%, both with a tempco of 50ppm/ $^{\circ}\text{C}$ guaranteed from -40°C to $+125^{\circ}\text{C}$.

The very low operating voltage, low supply current and power-down capability of the LM4121 makes this product an ideal choice for battery powered and portable applications.

The device performance is guaranteed over the industrial temperature range (-40°C to $+85^{\circ}\text{C}$), while certain specs are guaranteed over the extended temperature range (-40°C to $+125^{\circ}\text{C}$). Please contact National for full specifications over the extended temperature range. The LM4121 is available in a standard 5-pin SOT-23 package.

Features (LM4121-1.2)

- Small SOT23-5 package
- Low voltage operation
- High output voltage accuracy: 0.2%
- Source and Sink current output: $\pm 5\text{ mA}$
- Supply current: 160 μA Typ.
- Low Temperature Coefficient: 50 ppm/ $^{\circ}\text{C}$
- Enable pin
- Output voltages: 1.25V and Adjustable
- Industrial temperature Range: -40°C to $+85^{\circ}\text{C}$
- (For extended temperature range, -40°C to 125°C , contact National Semiconductor)

Applications

- Portable, battery powered equipment
- Instrumentation and process control
- Automotive & Industrial
- Test equipment
- Data acquisition systems
- Precision regulators
- Battery chargers
- Base stations
- Communications
- Medical equipment

LM4121-1.2 Block Diagram

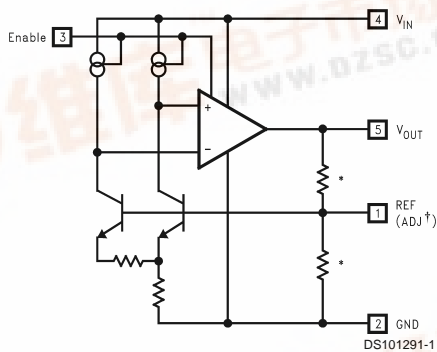

* Resistors are removed on the LM4121-ADJ
 †LM4121-ADJ only

Connection Diagram

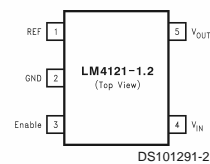

Refer to the Ordering Information Table in this Data Sheet for Specific Part Number

SOT23-5 Surface Mount Package

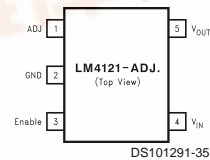

LM4121 Precision Micropower Low Dropout Voltage Reference

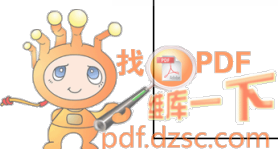

Ordering Information

Industrial Temperature Range (-40°C to $+85^{\circ}\text{C}$)

Initial Output Voltage Accuracy at 25°C And Temperature Coefficient	LM4121 Supplied as 1000 Units, Tape and Reel	LM4121 Supplied as 3000 Units, Tape and Reel	Top Marking
0.2%, 50 ppm/ $^{\circ}\text{C}$ max (A grade)	LM4121AIM5-1.2	LM4121AIM5X-1.2	R19A
	LM4121AIM5-ADJ	LM4121AIM5X-ADJ	R20A
0.5%, 50 ppm/ $^{\circ}\text{C}$ max	LM4121IM5-1.2	LM4121IM5X-1.2	R19B
	LM4121IM5-ADJ	LM4121IM5X-ADJ	R20B

SOT-23 Package Marking Information

Only four fields of marking are possible on the SOT-23's small surface. This table gives the meaning of the four fields.

Field Information
First Field: R = Reference Second and third Field: 19 = 1.250V Voltage Option 20 = Adjustable Fourth Field: A-B = Initial Reference Voltage Tolerance A = $\pm 0.2\%$ B = $\pm 0.5\%$

Absolute Maximum Ratings (Note 1)

If Military/Aerospace specified devices are required, please contact the National Semiconductor Sales Office/Distributors for availability and specifications.

Maximum Voltage on input or enable pins	-0.3V to 14V
Output Short-Circuit Duration	Indefinite
Power Dissipation ($T_A = 25^\circ\text{C}$) (Note 2):	
MA05B package – θ_{JA}	280°C/W
Power Dissipation	350 mW
ESD Susceptibility (Note 3)	
Human Body Model	2 kV
Machine Model	200V

Lead Temperature:

Soldering, (10 sec.)	+260°C
Vapor Phase (60 sec.)	+215°C
Infrared (15 sec.)	+220°C

Operating Range (Note 1)

Storage Temperature Range	-65°C to +150°C
Ambient Temperature Range	-40°C to +85°C
Junction Temperature Range	-40°C to +125°C

Electrical Characteristics

LM4121-1.250V Unless otherwise specified $V_{IN} = 3.3\text{V}$, $I_{LOAD} = 0$, $C_{OUT} = 0.01\mu\text{F}$, $T_A = T_j = 25^\circ\text{C}$. Limits with standard typeface are for $T_j = 25^\circ\text{C}$, and limits in **boldface type** apply over the $-40^\circ\text{C} \leq T_A \leq +85^\circ\text{C}$ temperature range.

Symbol	Parameter	Conditions	Min (Note 5)	Typ (Note 4)	Max (Note 5)	Units
V_{OUT}	Output Voltage Initial Accuracy LM4121A-1.250 LM4121-1.250			1.250	± 0.2 ± 0.5	%
$TCV_{OUT}/^\circ\text{C}$	Temperature Coefficient	$-40^\circ\text{C} \leq T_A \leq +125^\circ\text{C}$		14	50	ppm/°c
$\Delta V_{OUT}/\Delta V_{IN}$	Line Regulation	$1.8\text{V} \leq V_{IN} \leq 12\text{V}$		0.0007	0.009 0.012	%/V
$\Delta V_{OUT}/\Delta I_{LOAD}$	Load Regulation	$0\text{ mA} \leq I_{LOAD} \leq 1\text{ mA}$		0.03	0.08 0.17	%/mA
		$1\text{ mA} \leq I_{LOAD} \leq 5\text{ mA}$		0.01	0.04 0.1	
		$-1\text{ mA} \leq I_{LOAD} \leq 0\text{ mA}$		0.04	0.12	
		$-5\text{ mA} \leq I_{LOAD} \leq -1\text{ mA}$		0.01		
Min- V_{IN}	Minimum Operating Voltage	$I_{LOAD} = 5\text{mA}$		1.5	1.8	V
V_N	Output Noise Voltage	0.1 Hz to 10 Hz		20		μV_{PP}
		10 Hz to 10 kHz		30		μV_{RMS}
I_S	Supply Current			160	250 275	μA
I_{SS}	Power-down Supply Current	$V_{IN} = 12\text{V}$ Enable = 0.4V Enable = 0.2V			1 2	μA
V_H	Logic High Input Voltage		1.6	1.5		V
V_L	Logic Low Input Voltage			0.4		V
					0.2	
I_H	Logic High Input Current			7	15	μA
I_L	Logic Low Input Current			0.1		μA
I_{SC}	Short Circuit Current	$V_{IN} = 3.3\text{V}$, $V_{OUT} = 0$		15		mA
			6		30	
		$V_{IN} = 12\text{V}$, $V_{OUT} = 0$		17		
			6		30	
Hyst	Thermal Hysteresis (Note 8)	$-40^\circ\text{C} \leq T_A \leq 125^\circ\text{C}$		0.5		mV/V
ΔV_{OUT}	Long Term Stability (Note 9)	1000 hrs. @ 25°C		100		ppm

Electrical Characteristics

LM4121-ADJ

Unless otherwise specified $V_{IN} = 3.3V$, $V_{OUT} = V_{REF}$, $I_{LOAD} = 0$, $C_{OUT} = 0.01\mu F$, $T_A = T_J = 25^\circ C$. Limits with standard typeface are for $T_J = 25^\circ C$, and limits in **boldface type** apply over the $-40^\circ C \leq T_A \leq +85^\circ C$ temperature range.

Symbol	Parameter	Conditions	Min (Note 5)	Typ (Note 4)	Max (Note 5)	Units
$V_{OUT} = V_{REF}$	Output Voltage Initial Accuracy LM4121A-ADJ LM4121-ADJ			1.216	± 0.2 ± 0.5	%
$TCV_{REF}/^\circ C$	Temperature Coefficient	$-40^\circ C \leq T_A \leq +125^\circ C$		14	50	ppm/ $^\circ C$
$\Delta V_{REF}/\Delta V_{IN}$	Line Regulation	$1.8V \leq V_{IN} \leq 12V$		0.0007	0.009 0.012	%/V
$\Delta V_{OUT}/\Delta I_{LOAD}$	Load Regulation	$0 mA \leq I_{LOAD} \leq 1 mA$		0.03	0.08 0.17	%mA
		$1 mA \leq I_{LOAD} \leq 5 mA$		0.01	0.04 0.1	
		$-1 mA \leq I_{LOAD} \leq 0 mA$		0.04	0.12	
		$-5 mA \leq I_{LOAD} \leq -1 mA$		0.01		
Min- V_{IN}	Minimum Operating Voltage	$I_{LOAD} = 5 mA$		1.5	1.8	V
V_N	Output Noise Voltage (Note 6)	0.1 Hz to 10 Hz		20		μV_{PP}
		10 Hz to 10 kHz		30		μV_{RMS}
I_S	Supply Current			160	250 275	μA
I_{SS}	Power-down Supply Current	$V_{IN} = 12V$ Enable = 0.4V Enable = 0.2V			1 2	μA
I_{BIAS}	Reference Pin Bias Current	(Note 7)	15	40		nA
V_H	Logic High Input Voltage		1.6	1.5		V
V_L	Logic Low Input Voltage			0.4	0.2	V
I_H	Logic High Input Current			7	15	μA
I_L	Logic Low Input Current			0.1		μA
I_{SC}	Short Circuit Current	$V_{OUT} = 0$		15	30	mA
			6			
		$V_{IN} = 12V$, $V_{OUT} = 0$		17	30	
			6		30	
Hyst	Thermal Hysteresis (Note 8)	$-40^\circ C \leq T_A \leq 125^\circ C$		0.5		mV/V
ΔV_{OUT}	Long Term Stability (Note 9)	1000 hrs. @ $25^\circ C$		100		ppm

Note 1: "Absolute Maximum Ratings" indicate limits beyond which damage to the device may occur. Operating Ratings indicate conditions for which the device is intended to be functional, but do not guarantee specific performance limits. For guaranteed specifications and test conditions, see Electrical Characteristics. The guaranteed specifications apply only for the test conditions listed. Some performance characteristics may degrade when the device is not operated under the listed test conditions.

Note 2: Without PCB copper enhancements. The maximum power dissipation must be derated at elevated temperatures and is limited by T_{JMAX} (maximum junction temperature), θ_{JA} (junction to ambient thermal resistance) and T_A (ambient temperature). The maximum power dissipation at any temperature is: $PD_{ISSMAX} = (T_{JMAX} - T_A)/\theta_{JA}$ up to the value listed in the Absolute Maximum Ratings.

Note 3: The human body model is a 100 pF capacitor discharged through a 1.5 k Ω resistor into each pin. The machine model is a 200 pF capacitor discharged directly into each pin.

Note 4: Typical numbers are at $25^\circ C$ and represent the most likely parametric norm.

Note 5: Limits are 100% production tested at $25^\circ C$. Limits over the operating temperature range are guaranteed through correlation using Statistical Quality Control (SQC) methods. The limits are used to calculate National's Averaging Outgoing Quality Level (AOQL).

Note 6: Output noise for 1.25V option. Noise is proportional to V_{OUT} .

Note 7: Bias Current flows out of the Adjust pin.

Note 8: Thermal hysteresis is defined as the change in $+25^\circ C$ output voltage before and after exposing the device to temperature extremes.

Note 9: Long term stability is change in V_{REF} at $25^\circ C$ measured continuously during 1000 hrs.

LM4121- (All Options) Typical Operating Characteristics Unless otherwise specified, $V_{IN} = 3.3V$, $V_{OUT} = 1.25V$, $I_{LOAD} = 0$, $C_{OUT} = 0.022\mu F$, $T_A = 25^\circ C$ and $V_{EN} = V_{IN}$.

Minimum Input Voltage vs Temperature

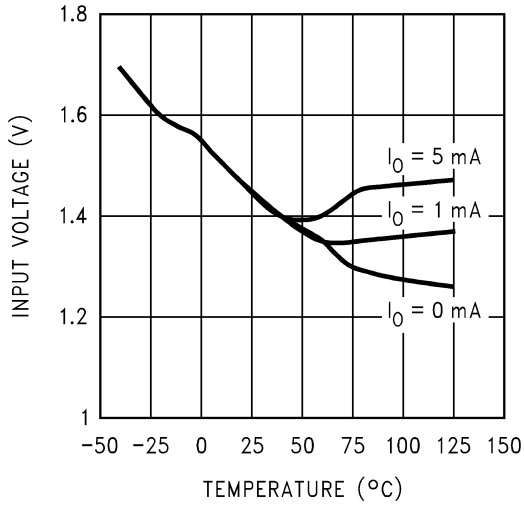

DS101291-12

GND Pin Current vs V_{IN}

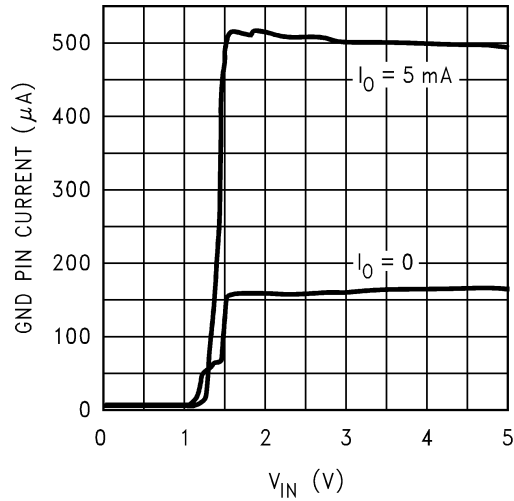

DS101291-13

GND Pin Current at No Load vs Temperature

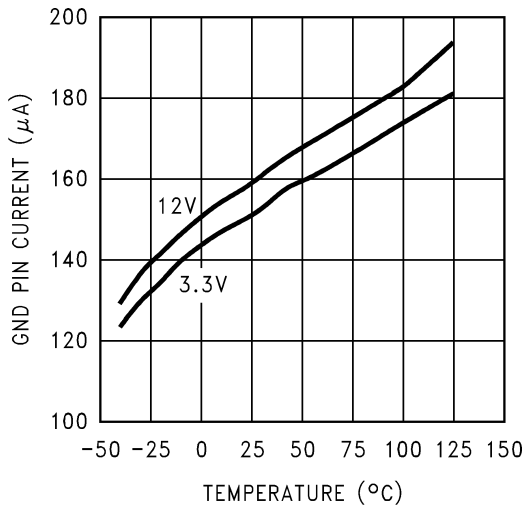

DS101291-14

GND Pin Current vs Load

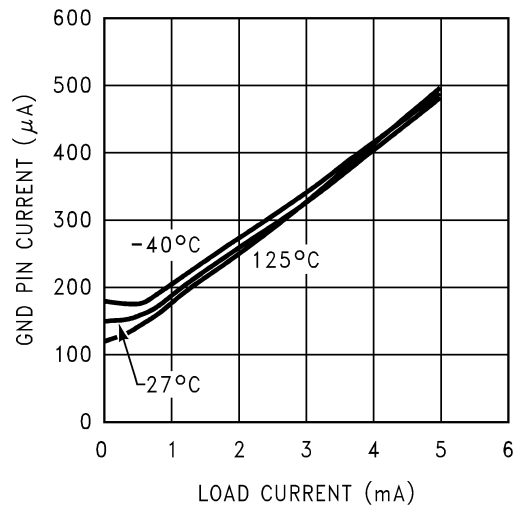

DS101291-15

LM4121- (All Options) Typical Operating Characteristics Unless otherwise specified, $V_{IN} = 3.3V$, $V_{OUT} = 1.25V$, $I_{LOAD} = 0$, $C_{OUT} = 0.022\mu F$, $T_A = 25^\circ C$ and $V_{EN} = V_{IN}$. (Continued)

Short Circuit vs Temperature

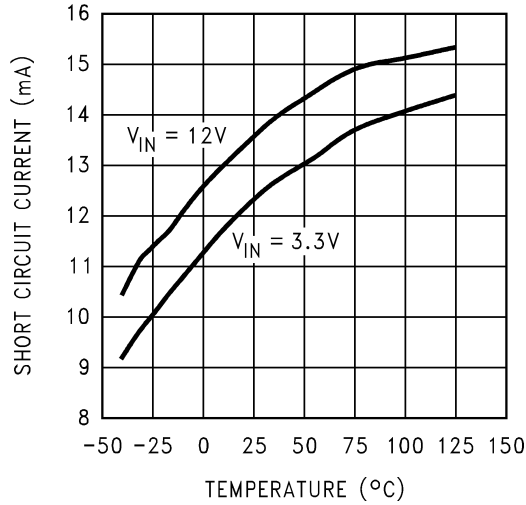

Output Impedance vs Frequency

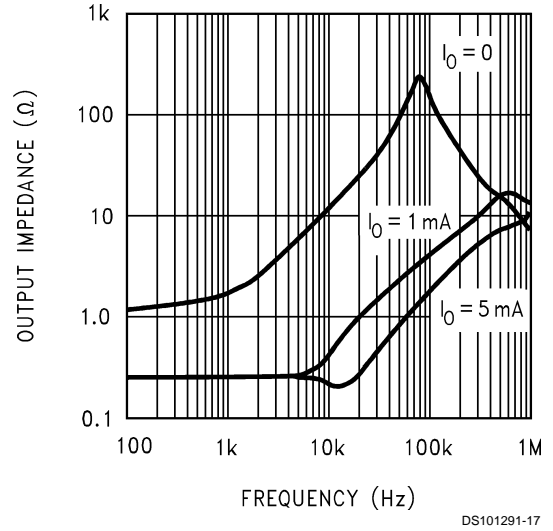

PSRR vs Frequency

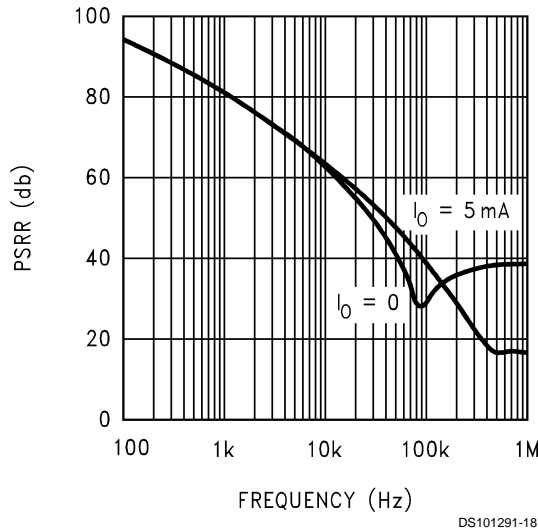

Enable Pin Current

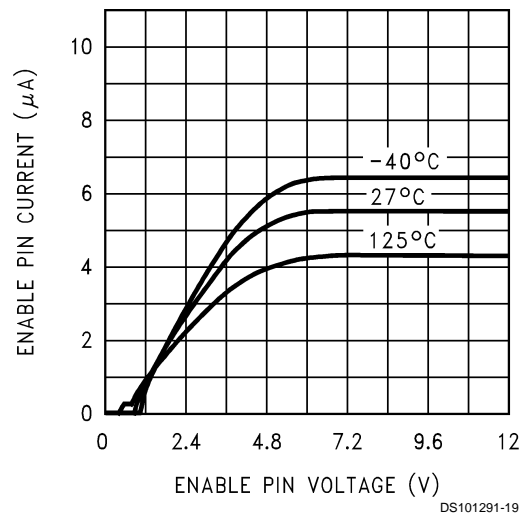

LM4121- (All Options) Typical Operating Characteristics

Unless otherwise specified, $V_{IN} = 3.3V$, $V_{OUT} = 1.25V$, $I_{LOAD} = 0$, $C_{OUT} = 0.022\mu F$, $T_A = 25^\circ C$ and $V_{EN} = V_{IN}$. (Continued)

Start-Up Response

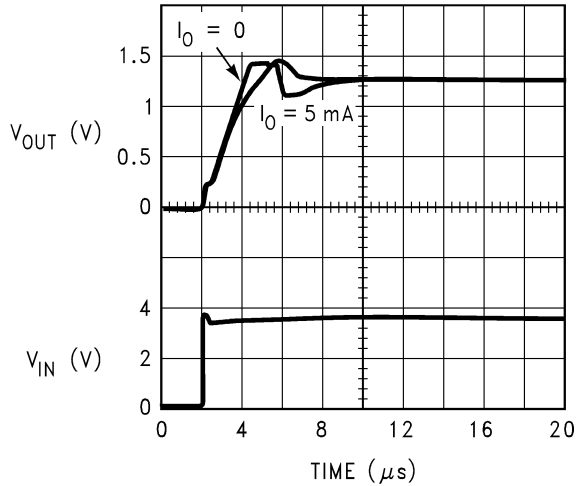

DS101291-21

Enable Response

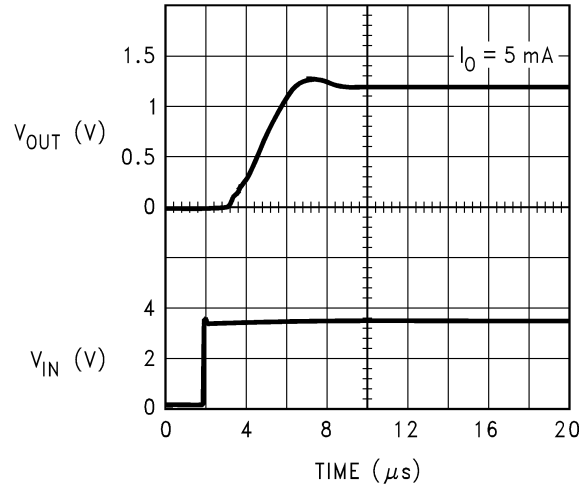

DS101291-22

Load Step Response

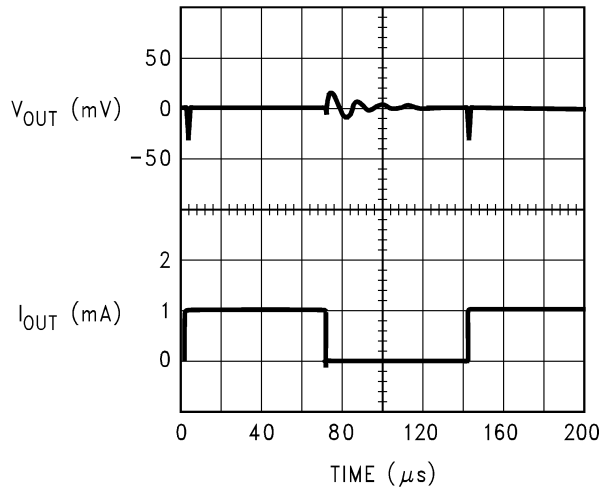

DS101291-23

Load Step Response

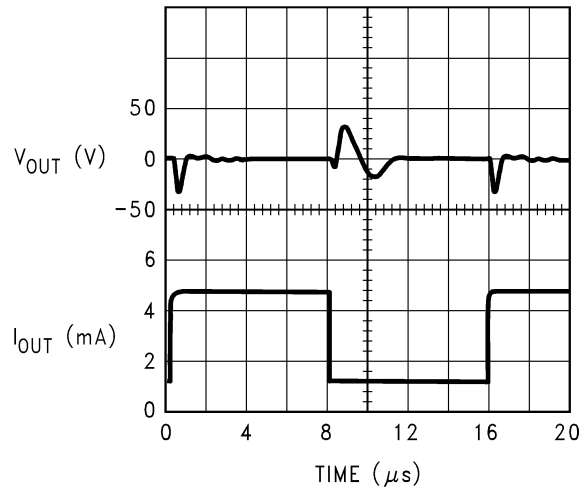

DS101291-24

LM4121- (All Options) Typical Operating Characteristics Unless otherwise specified, $V_{IN} = 3.3V$, $V_{OUT} = 1.25V$, $I_{LOAD} = 0$, $C_{OUT} = 0.022\mu F$, $T_A = 25^\circ C$ and $V_{EN} = V_{IN}$. (Continued)

Line Step Response

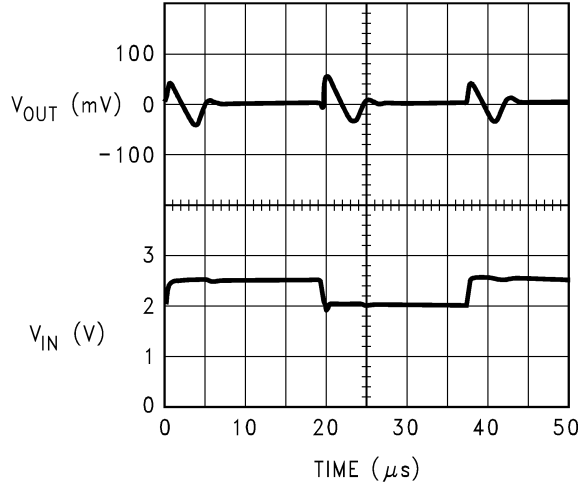

DS101291-25

Noise Spectral Density (0.1Hz-10Hz)

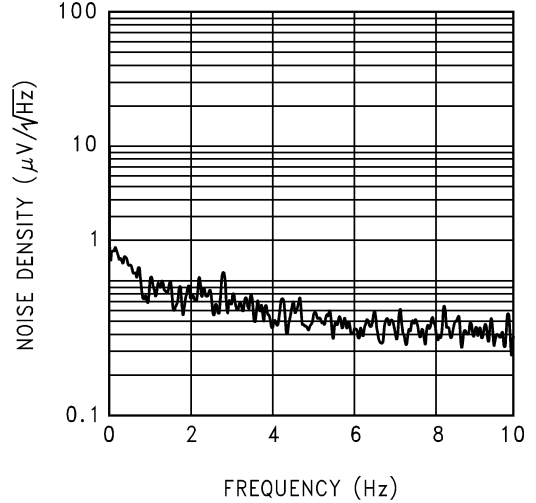

DS101291-26

Noise Spectral Density (10Hz-10kHz)

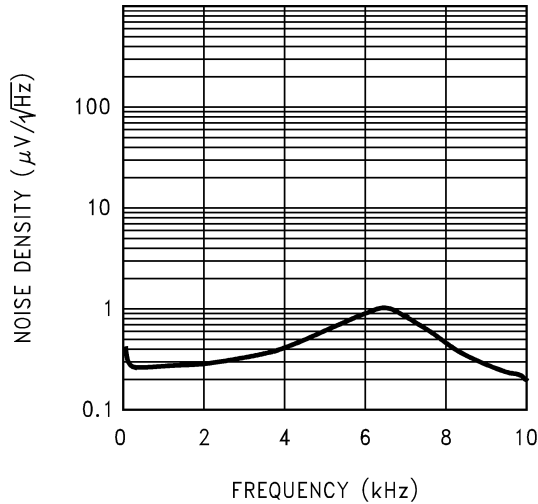

DS101291-27

Thermal Hysteresis

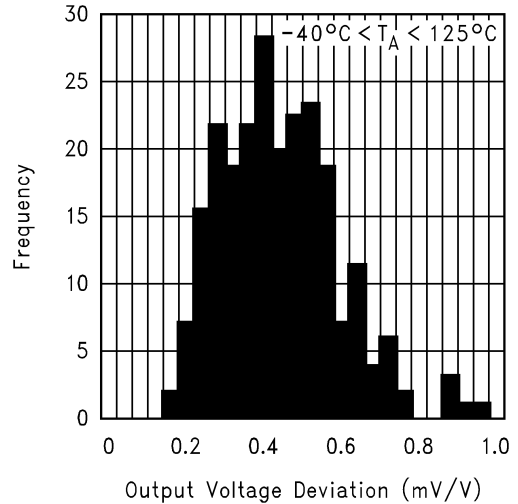

DS101291-46

LM4121-1.25 Typical Operating Characteristics Unless otherwise specified, $V_{IN} = 3.3V$, $V_{OUT} = 1.25V$, $I_{LOAD} = 0$, $C_{OUT} = 0.022\mu F$, $T_A = 25^\circ C$ and $V_{EN} = V_{IN}$.

Typical Temperature Drift

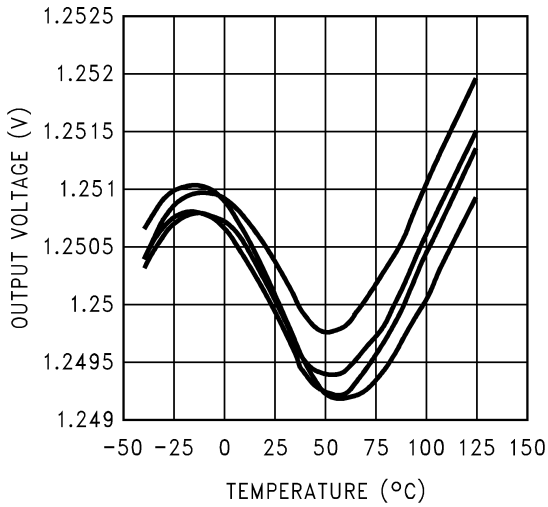

DS101291-28

Long Term Drift

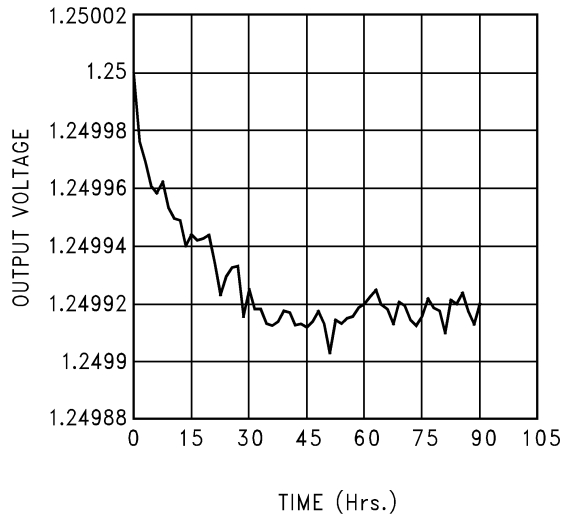

DS101291-29

Line Regulation

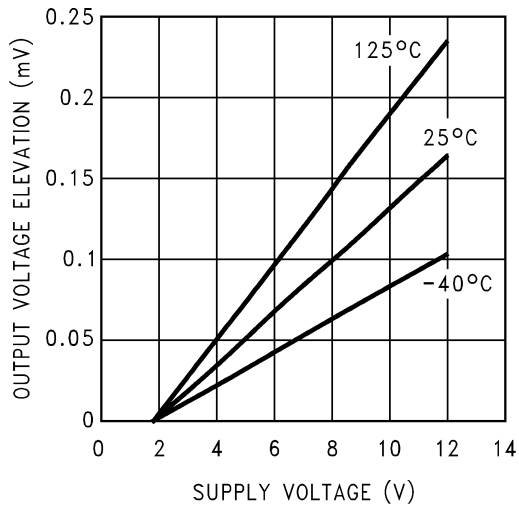

DS101291-30

Load Regulation

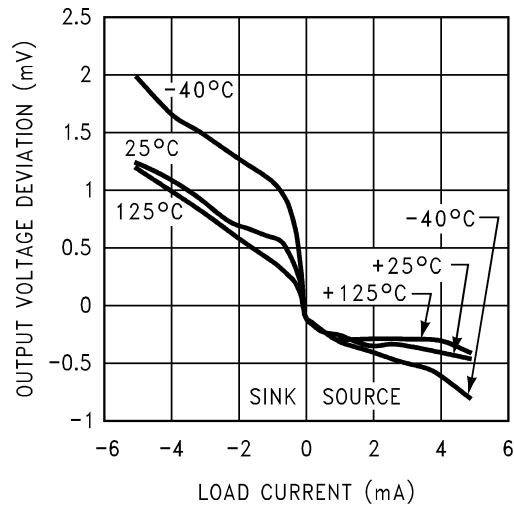

DS101291-31

LM4121-ADJ Typical Operating Characteristics Unless otherwise specified, $V_{IN} = 3.3V$, $V_{OUT} = 1.2V$, $I_{LOAD} = 0$, $C_{OUT} = 0.022\mu F$, $T_A = 25^\circ C$ and $V_{EN} = V_{IN}$.

Typical Temperature Drift

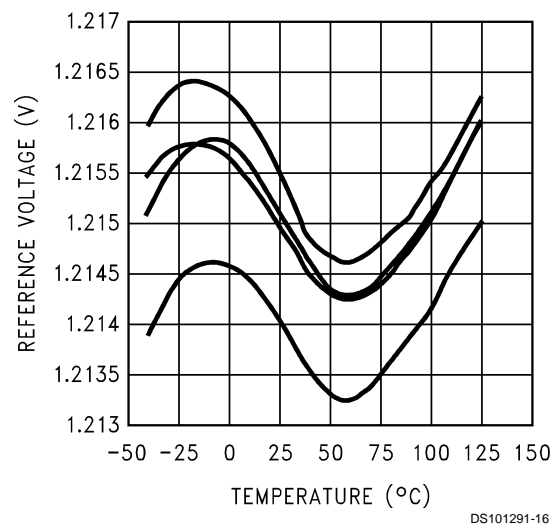

Long Term Drift

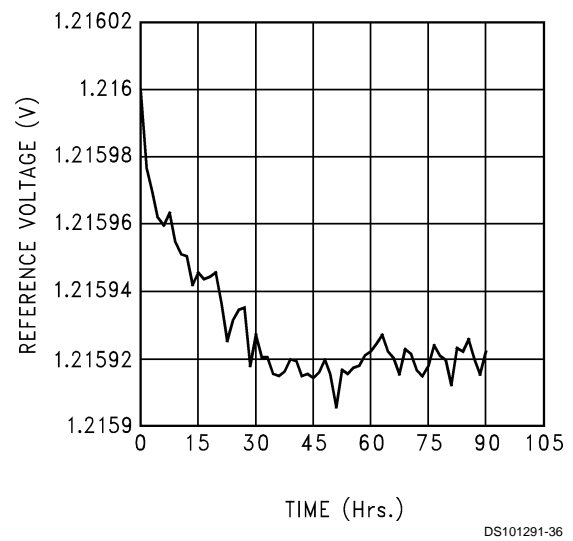

Dropout Voltage vs Output Error

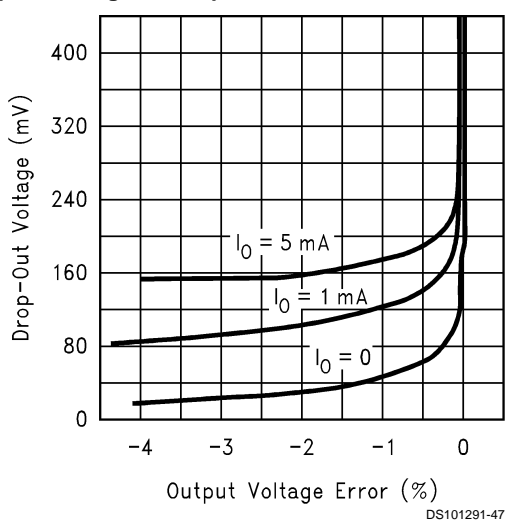

Dropout Voltage vs Load Current

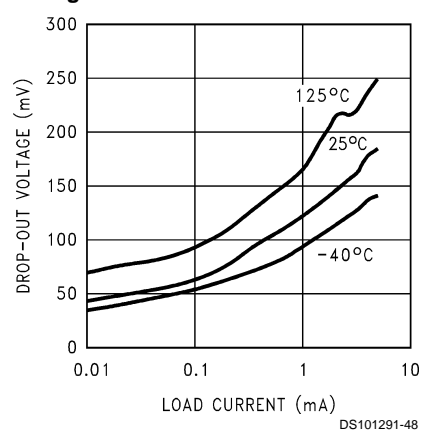

LM4121-ADJ Typical Operating Characteristics Unless otherwise specified, $V_{IN} = 3.3V$, $V_{OUT} = 1.2V$, $I_{LOAD} = 0$, $C_{OUT} = 0.022\mu F$, $T_A = 25^\circ C$ and $V_{EN} = V_{IN}$. (Continued)

Line Regulation

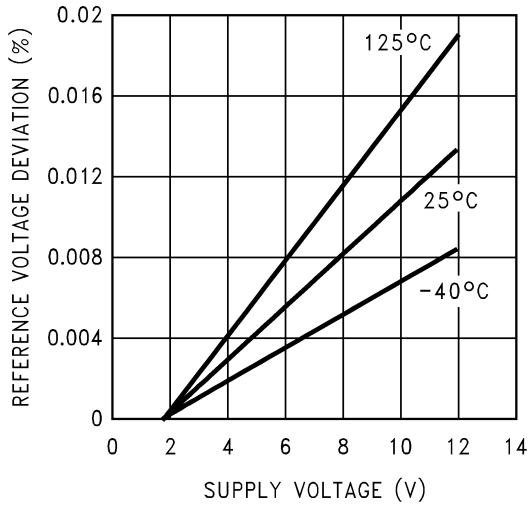

DS101291-37

Load Regulation

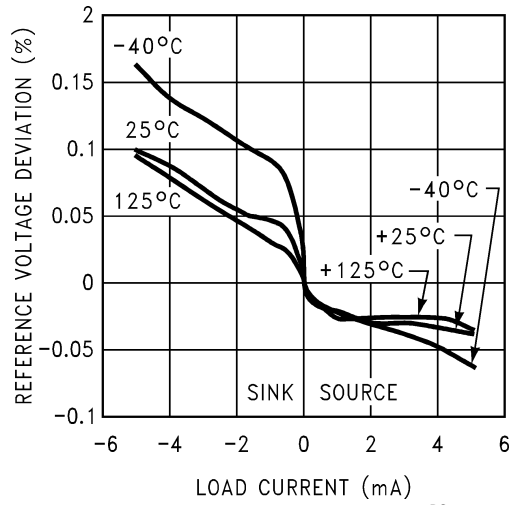

DS101291-38

Adjust Pin Bias Current

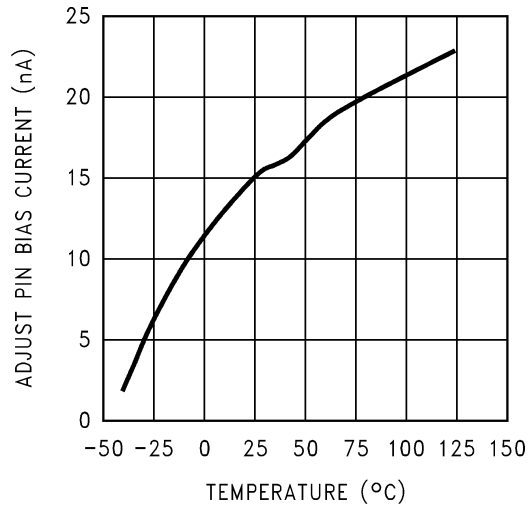

DS101291-39

Change In Reference Voltage vs Output Voltage

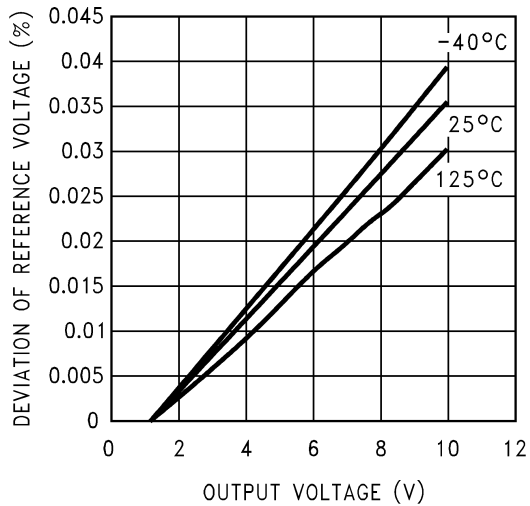

DS101291-40

LM4121-ADJ Typical Operating Characteristics Unless otherwise specified, $V_{IN} = 3.3V$, $V_{OUT} = 1.2V$, $I_{LOAD} = 0$, $C_{OUT} = 0.022\mu F$, $T_A = 25^\circ C$ and $V_{EN} = V_{IN}$. (Continued)

Bode Plot

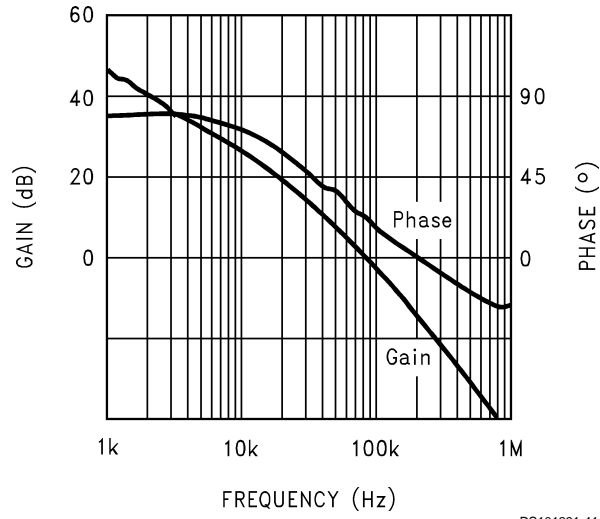

Bode Plot

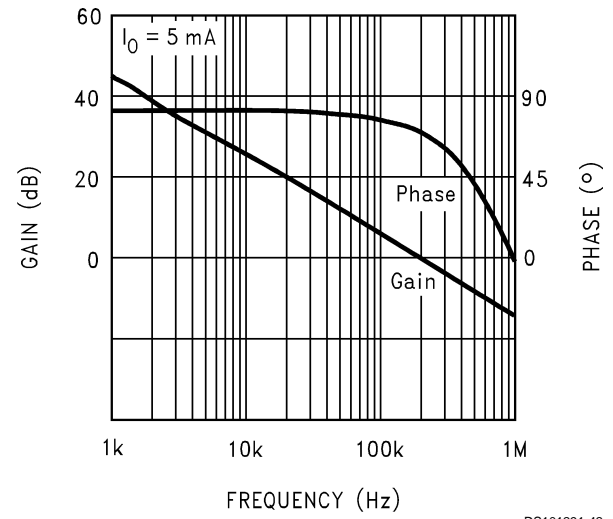

Pin Functions

Output (Pin 5): Reference Output.

Input (Pin 4): Positive Supply.

Ground (Pin 2): Negative Supply or Ground Connection.

Enable (Pin 3): Pulled to input for normal operation. Forcing this pin to ground will turn-off the output.

REF (Pin 1): REF Pin (1.25V option only). This pin should be left unconnected for 1.25V option.

Adj (Pin 1): V_{OUT} Adj Pin (Adjustable option only). See Application Hints section.

Application Hints

The standard application circuit for the LM4121 is shown in Figure 1. The output voltage is set with the two feedback resistors, according to the following formula:

$$V_{OUT} = [V_{ref}(1 + R1/R2)] - I_{bias} \cdot R1$$

Values for R1 and R2 should be chosen to be less than 1 M Ω . I_{bias} typically flows out of the adjust pin. Values for V_{ref} and I_{bias} are found in the Electrical Characteristics Spec. table. For best accuracy, be sure to take into account the variation of V_{REF} with input voltage, load and output voltage.

The LM4121 is designed to be stable with ceramic output capacitors in the range of 0.022 μ F to 0.047 μ F. Note that 0.022 μ F is the minimum required output capacitor. These capacitors typically have an ESR of about 0.1 to 0.5 Ω . Smaller ESR can be tolerated, however larger ESR can not. The output capacitor can be increased to improve load transient response, up to about 1 μ F. However, values above 0.047 μ F must be tantalum. With tantalum capacitors, in the 1 μ F range, a small capacitor between the output and the reference (Adj) pin is required. This capacitor will typically be in the 50pF range. Care must be taken when using output capacitors of 1 μ F or larger. These application must be thoroughly tested over temperature, line and load. Also, when the LM4121 is used as a controller, with external active components, each application must be carefully tested to ensure a stable design. The adjust pin is sensitive to noise and capacitive loading. The trace to this pin must be as short as possible and the feedback resistors should be close to this pin. Also, a single point ground to the LM4121 will help ensure good accuracy at high load currents.

An input capacitor is typically not required. However, a 0.1 μ F ceramic can be used to help prevent line transients from entering the LM4121. Larger input capacitors should be tantalum or aluminium.

The enable pin is an analog input with very little hysteresis. About 6 μ A into this pin is required to turn the part on, and it must be taken close to GND to turn the part off (see spec. table for thresholds). There is a *minimum* slew rate on this pin of about 0.003V/ μ S to prevent glitches on the output. All of these conditions can easily be met with ordinary CMOS or TTL logic. If the shutdown feature is not required, then this pin can safely be connected directly to the input supply. Floating this pin is not recommended.

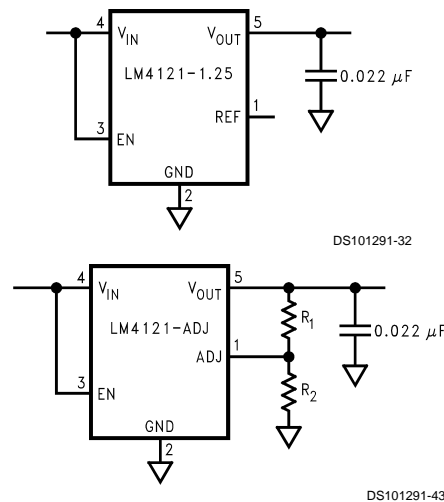

FIGURE 1. Standard Application Circuit

Printed Circuit Board Layout Consideration

The mechanical stress due to PC board mounting can cause the output voltage to shift from its initial value. References in SOT packages are generally less prone to assembly stress than devices in Small Outline (SOIC) package.

To reduce the stress-related output voltage shifts, mount the reference on the low flex areas of the PC board such as near to the edge or the corner of the PC board.

Typical Application Circuits

Voltage Reference with Negative Output

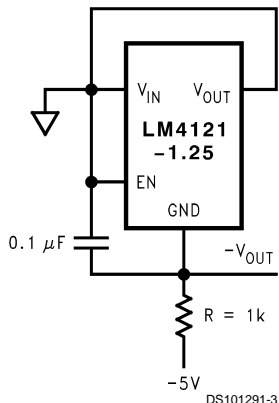

DS101291-3

Voltage Reference with Complimentary Output

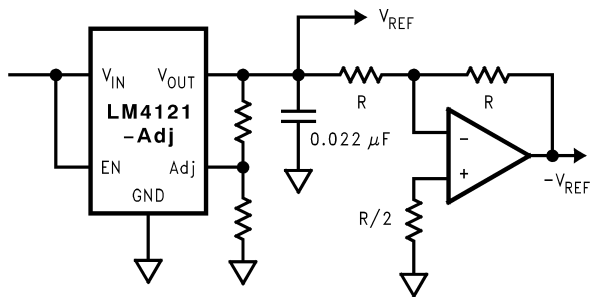

DS101291-6

100mA Quasi-LDO Regulator

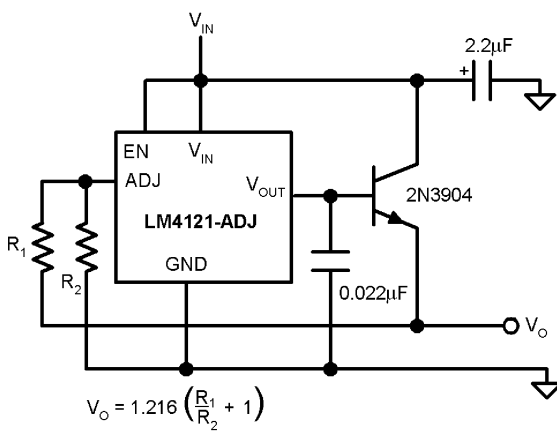

$$V_o = 1.216 \left(\frac{R_1}{R_2} + 1 \right)$$

DS101291-4

Two Terminal Constant Current Source

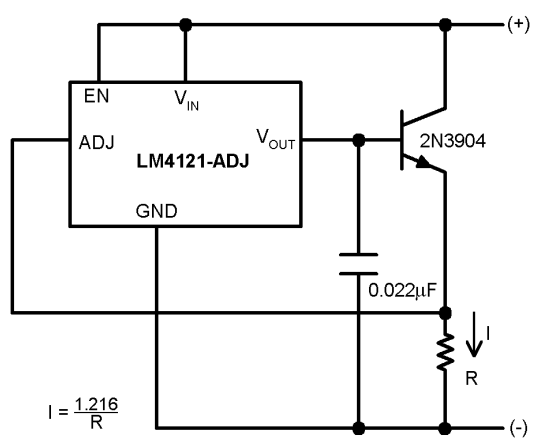

$$I = \frac{1.216}{R}$$

DS101291-7

Boosted Output Current with Negative Voltage Reference

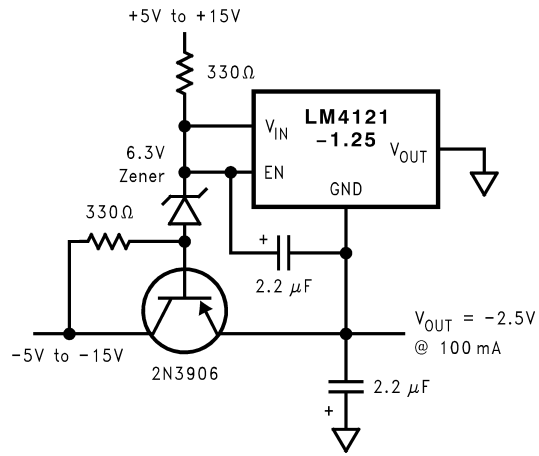

DS101291-5

Precision Voltage Reference with Force and Sense Output

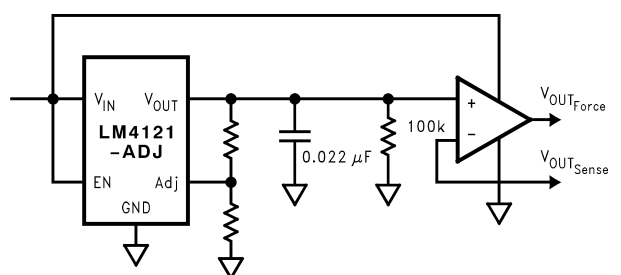

DS101291-9

Typical Application Circuits

(Continued)

Programmable Current Source

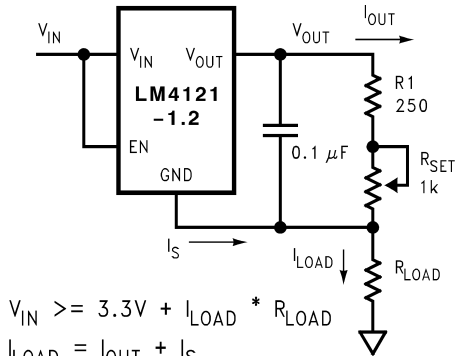

$$V_{IN} \geq 3.3V + I_{LOAD} * R_{LOAD}$$

$$I_{LOAD} = I_{OUT} + I_S$$

$$I_{OUT} = V_{OUT} / (R_1 + R_{SET})$$

DS101291-10

Precision Comparator with Hysteresis

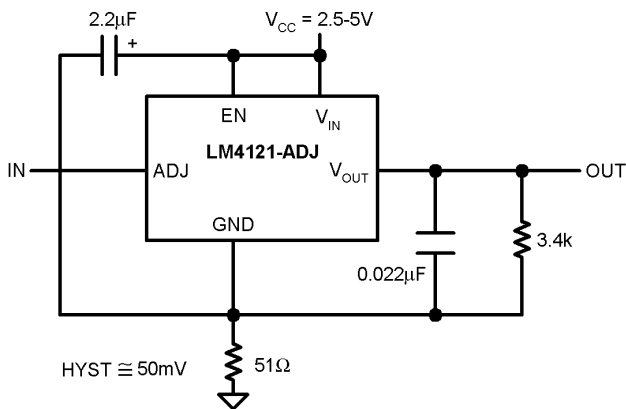

HYST \cong 50mV

DS101291-11

Power Supply Splitter

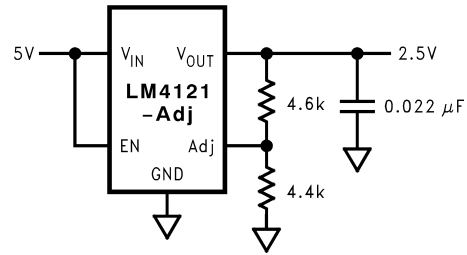

DS101291-20

Li + Low Battery Detector

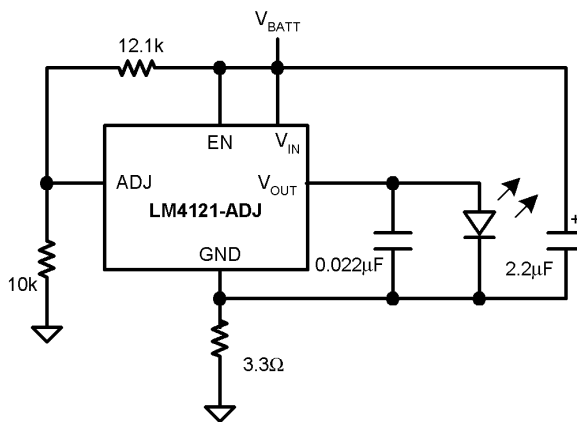

LED = ON @ \cong 2.7V
LED = OFF @ \cong 2.8V

DS101291-44

Flasher Circuit

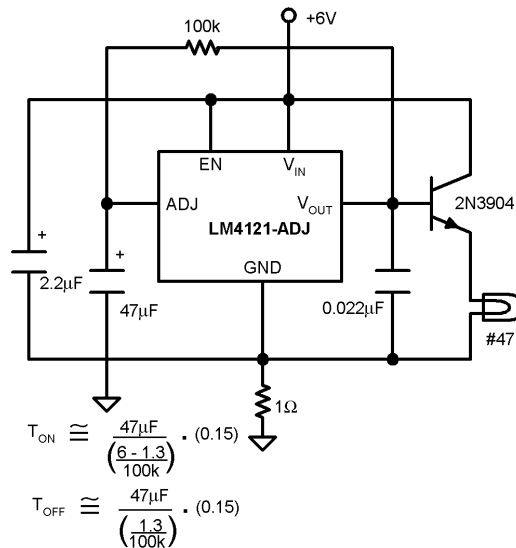

$$T_{ON} \cong \frac{47\mu F}{\left(\frac{6-1.3}{100k}\right)} \cdot (0.15)$$

$$T_{OFF} \cong \frac{47\mu F}{\left(\frac{1.3}{100k}\right)} \cdot (0.15)$$

DS101291-45

Physical Dimensions inches (millimeters) unless otherwise noted

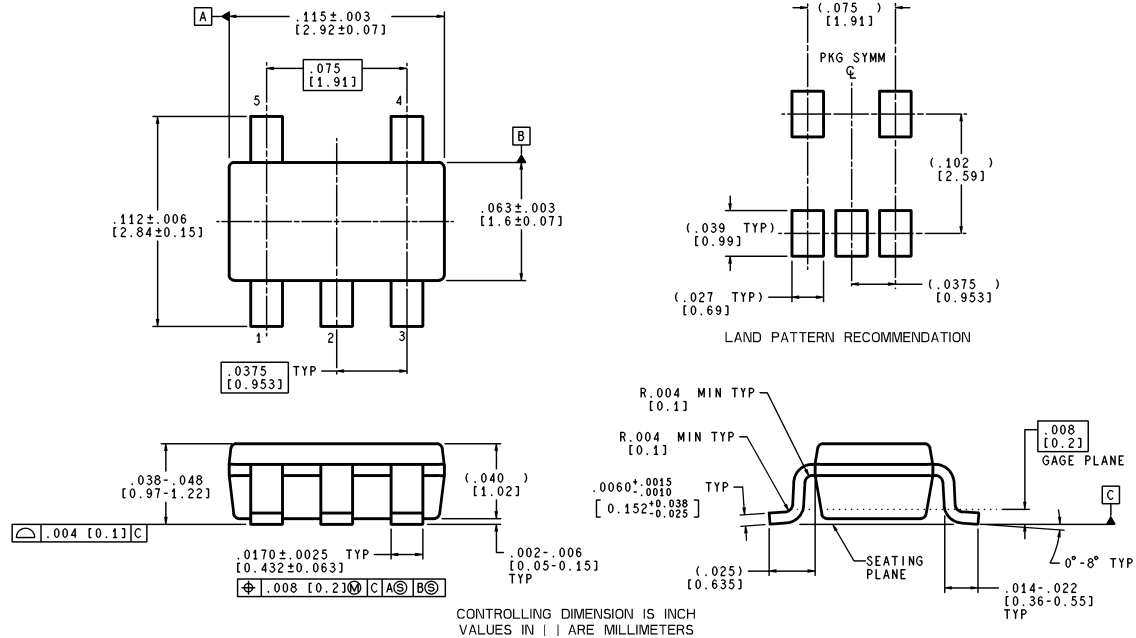

MF05A (Rev A)

LIFE SUPPORT POLICY

NATIONAL'S PRODUCTS ARE NOT AUTHORIZED FOR USE AS CRITICAL COMPONENTS IN LIFE SUPPORT DEVICES OR SYSTEMS WITHOUT THE EXPRESS WRITTEN APPROVAL OF THE PRESIDENT AND GENERAL COUNSEL OF NATIONAL SEMICONDUCTOR CORPORATION. As used herein:

1. Life support devices or systems are devices or systems which, (a) are intended for surgical implant into the body, or (b) support or sustain life, and whose failure to perform when properly used in accordance with instructions for use provided in the labeling, can be reasonably expected to result in a significant injury to the user.
2. A critical component is any component of a life support device or system whose failure to perform can be reasonably expected to cause the failure of the life support device or system, or to affect its safety or effectiveness.



National Semiconductor Corporation
 Americas
 Tel: 1-800-272-9959
 Fax: 1-800-737-7018
 Email: support@nsc.com
 www.national.com

National Semiconductor Europe
 Fax: +49 (0) 180-530 85 86
 Email: europe.support@nsc.com
 Deutsch Tel: +49 (0) 69 9508 6208
 English Tel: +44 (0) 870 24 0 2171
 Français Tel: +33 (0) 1 41 91 8790

National Semiconductor Asia Pacific Customer Response Group
 Tel: 65-2544466
 Fax: 65-2504466
 Email: ap.support@nsc.com

National Semiconductor Japan Ltd.
 Tel: 81-3-5639-7560
 Fax: 81-3-5639-7507