

# Schottky Barrier Diodes 30V

V <sub>RM</sub> (V)	Package	Part Number	I <sub>F</sub> (AV) (A)	I <sub>FSM</sub> (A)	T <sub>j</sub> (°C)	T <sub>stg</sub> (°C)	V <sub>F</sub> (V) max	I <sub>F</sub> (A)	I <sub>R</sub> (mA)	I <sub>R</sub> (H) (mA)	R <sub>th(j-ℓ)</sub> R <sub>th(j-c)</sub> (°C/W)	Mass (g)	Fig. No.	Page where characteristic curve is shown
				50Hz Half-cycle Sinewave Single Shot				V <sub>R</sub> =V <sub>RM</sub> max	V <sub>R</sub> =V <sub>RM</sub> max	T <sub>a</sub> (°C)				
30	Surface Mount	MI1A3	1.0	12	-40 to +150	0.47	1.0	1	70	150 (Tj)	70	0.011	1	82
		MI2A3 *	1.0	12	-40 to +125	0.39	1.0	2	110	125 (Tj)	70	0.011		
		SFPA-53	1.0	30	-40 to +125	0.36	1.0	1.5	70	100	20	0.072		
		SFPJ-53 *	1.0	30	-40 to +150	0.45	1.0	1.0	35	150	20	0.072	2	
		SFPA-63	2.0	40	-40 to +125	0.36	2.0	3.0	140	100	20	0.072		
		SFPE-63 *	2.0	40	-40 to +150	0.55	2.0	0.2	20	150 (Tj)	20	0.072		
		SFPJ-63	2.0	40	-40 to +150	0.45	2.0	2.0	70	150	20	0.072		
		SFPA-73	3.0	50	-40 to +125	0.36	3.0	4.5	210	100	20	0.072	3	
		SFPJ-73	3.0	50	-40 to +150	0.45	3.0	3.0	100	150	20	0.072		
		SPJ-G53S	5.0	100	-40 to +150	0.45	5.0	5.0	250	150	5	0.29		
Surface Mount Center-tap	SPJ-63S	6.0	50	-40 to +150	0.45	3.0	3	100	150 (Tj)	5	0.29	3		
Axial	AK 03	1.0	25	-40 to +150	0.55	1.0	1	50	100 (Tj)	22	0.13	4	85	
	EA 03	1.0	30	-40 to +125	0.36	1.0	1.5	70	100	20	0.3	5	—	
	EK 03	1.0	40	-40 to +150	0.55	1.0	5	50	100	20	0.3	6	86	
	EK 13	1.5	40	-40 to +150	0.55	2.0	5	50	100	17	0.3	7	87	
	RK 13	1.7	60	-40 to +150	0.55	2.0	5	50	100	15	0.45	8	—	
	RA 13	2.0	40	-40 to +125	0.36	2.0	3	140	100	15	0.45	9	87	
	RK 33	2.5	50	-40 to +150	0.55	2.5	5	50	100	12	0.6	8	87	
	RJ 43	3.0	50	-40 to +150	0.45	3.0	3	100	150	8	1.2	9	88	
	RK 43	3.0	80	-40 to +150	0.55	3.0	5	50	100	8	1.2	9		
Center-tap	FMJ-23L	10	100	-40 to +150	0.45	5.0	5	250	150 (Tj)	4	2.1	10	93	
	FMJ-2203	20	150	-40 to +150	0.47	10.0	10	350	150	4	2.1	10	—	
	FMJ-2303	30	150	-40 to +150	0.48	15.0	15	500	150	4	2.1	10	—	

\* : Under development

## External Dimensions Flammability: UL94V-0 or Equivalent (Unit: mm)

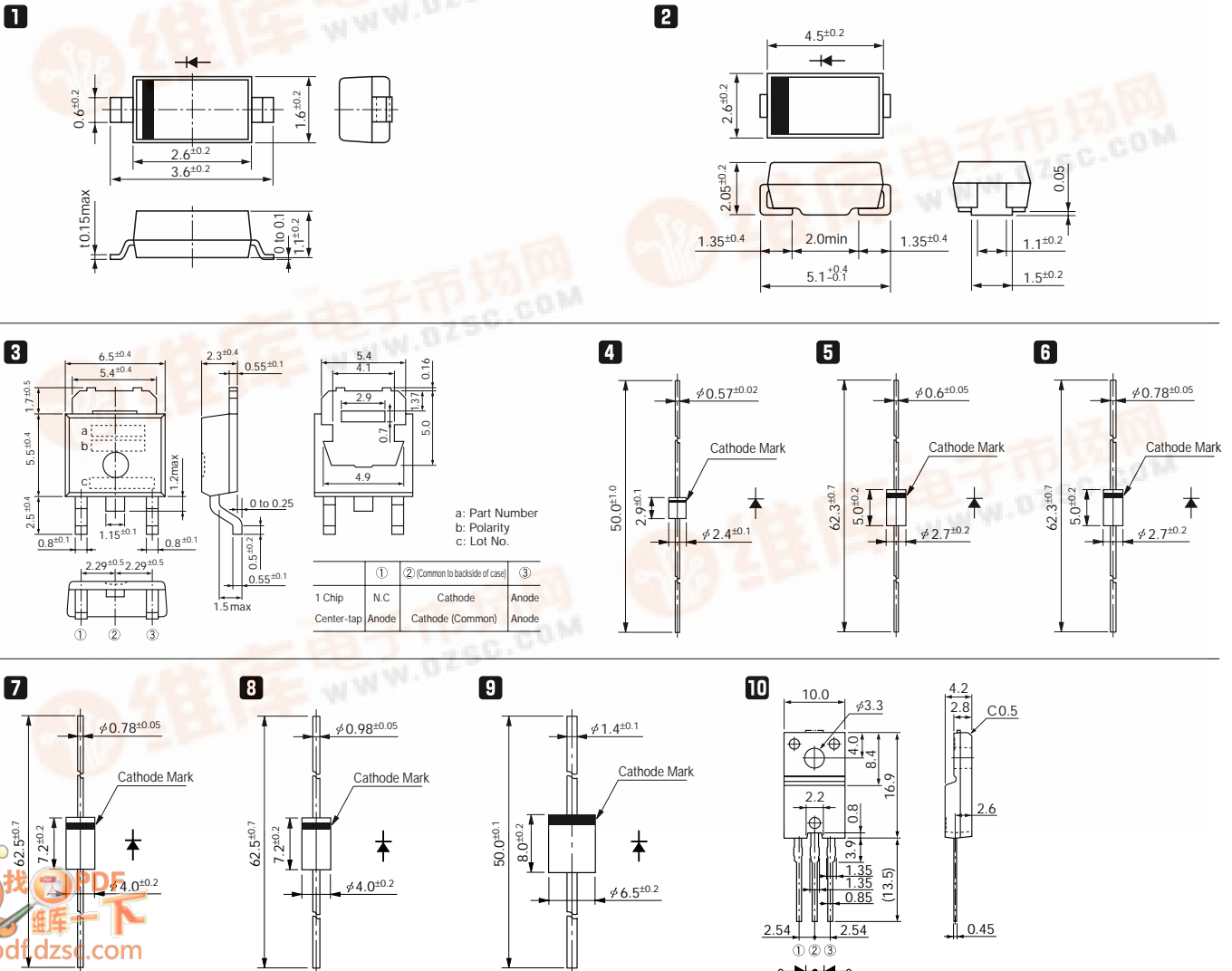

# Characteristic Curves Schottky Barrier Diodes

## MI1A3

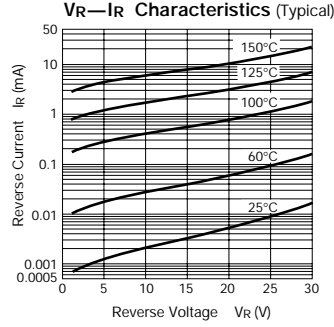
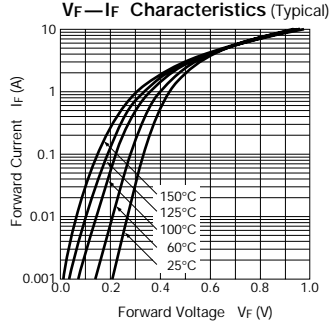
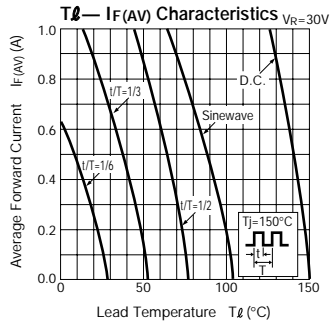

## SFPB-54

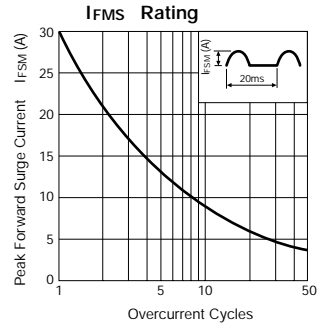
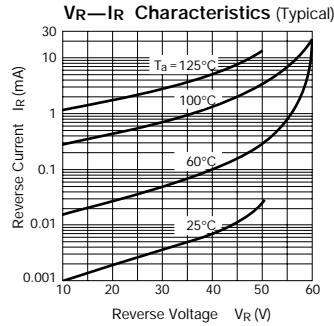
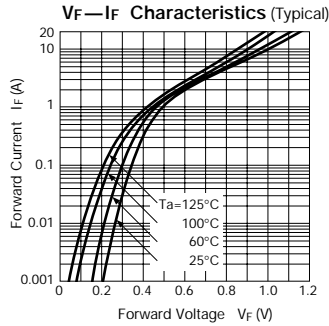
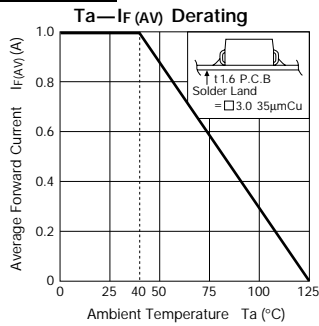

## SFPB-56

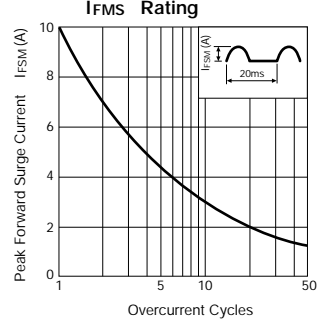
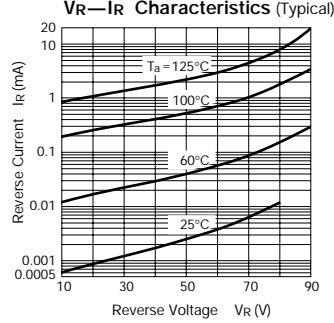
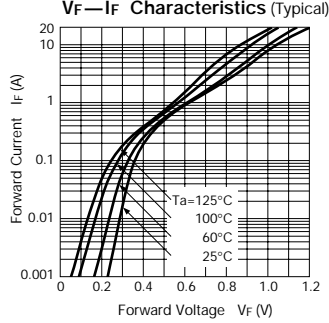
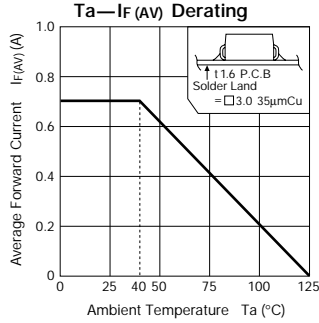

## SFPB-59

