



AME1085

3A Low Dropout Positive Voltage Regulator

General Description

The AME1085 is a 3A low-dropout positive voltage regulator. It is available in fixed and adjustable output voltage versions. Overcurrent and thermal protection are integrated onto the chip. Output current will limit as it reaches the pre-set current or temperature limit. At full rated output current the dropout voltage is 1.4V (max.). AME1085 series regulators provide excellent regulation over line, load and temperature variations.

Key Features

- Low dropout voltage 1.2V typically at 3A
- Adjustable or 3.3V fixed voltage
- Line regulation typically 0.015%
- Load regulation typically 0.05%
- Adjust pin (ADJ) current less than 90 μ A
- Overcurrent protection
- Thermal protection
- Available in TO-220, TO-263, TO-252

Applications

- High Efficiency Linear Regulators
- Post Regulators for Switching Supplies
- 5V to 3.3V Voltage Converter
- Battery Charger

Functional Block Diagram

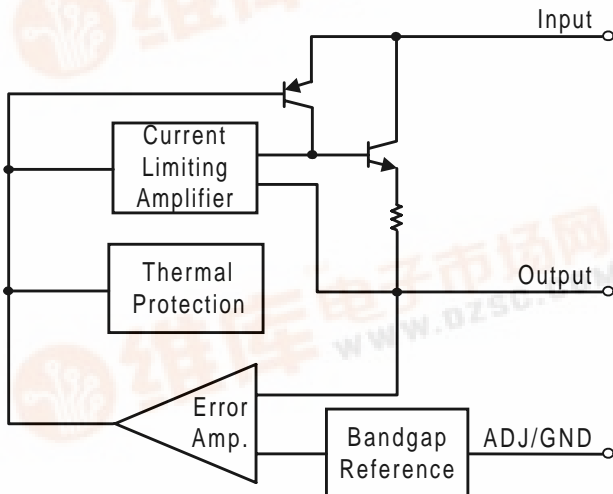

Figure 1

Typical Application

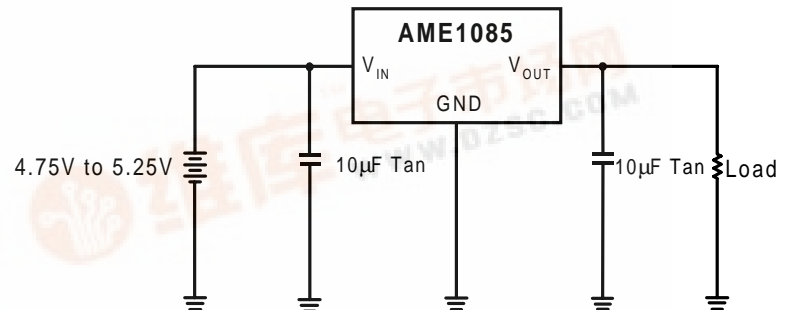
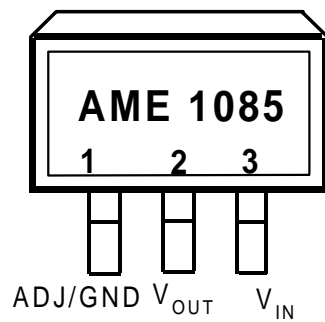

Figure 2



■ Pin Configuration

To-263 Front View



To-263-2 Front View

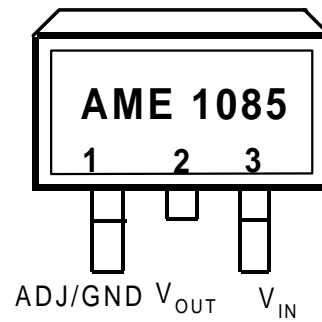

To-252-2 Front View

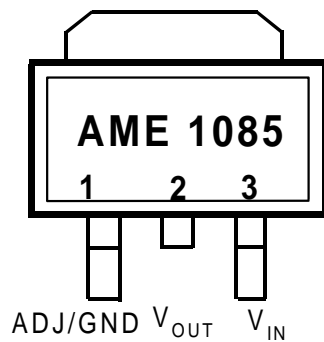

TO-252-2 Front view

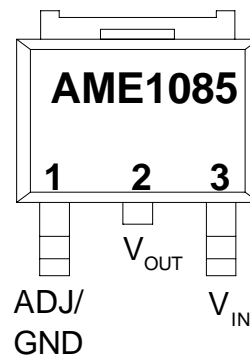



■ Ordering Information

Part Number	Marking	Output Voltage	Package
AME1085ACBT	AME1085 ACBT YYWW	ADJ	TO-220
AME1085DCBT	AME1085 DCBT YYWW	3.3	TO-220
AME1085ACDT-3	AME1085 ACDT-3 YYWW	ADJ	TO-263-3
AME1085DCDT-3	AME1085 DCDT-3 YYWW	3.3	TO-263-3
AME1085ACDT	AME1085 ACDT YYWW	ADJ	TO-263-2
AME1085DCDT	AME1085 DCDT YYWW	3.3	TO-263-2
AME1085AMCT	AME1085 AMCT YYWW	ADJ	TO-252-2
AME1085MCT*	AME1085 MCT YYWW	3.3	TO-252-2

* This differs from our standard part numbering scheme due to historical precedent

■ Absolute Maximum Ratings

Parameter	Symbol	Maximum	Units
Input Voltage	V_{IN}	7	V
Thermal Resistance (Junction to Case)	TO-220	2.5	$^{\circ}\text{C}/\text{W}$
	TO-263	2.5	
	TO-252	15	
Thermal Resistance (Junction to Ambient)	TO-220	50	$^{\circ}\text{C}$
	TO-263	60	
	TO-252	90	
Operating Junction Temperature Range	T_J	0 to 125	$^{\circ}\text{C}$
Storage Temperature Range	T_{STG}	-65 to 150	
Lead Temperature (10 sec)	T_{LEAD}	260	



■ Electrical Characteristics

AME1085AXXX

Parameter	Symbol	Test Conditions	Min.	Typ.	Max.	Units	
Reference voltage (adjustable voltage)	V_{REF}	$V_{IN} = 5V$ $I_O = 10mA$	$T_J = 25^{\circ}C$	1.238	1.250	1.262	V
			Over temp.	1.225		1.275	
Line regulation	Reg_{LINE}	$V_{IN} = 2.75 - 7V$ $I_O = 10mA$	$T_J = 25^{\circ}C$	-	0.015	0.2	%
			Over temp.	-	0.035	0.2	
Load regulation	Reg_{LOAD}	$V_{IN} = 5V$ $I_O = 10mA - 3A$	$T_J = 25^{\circ}C$	-	0.05	0.3	%
			Over temp.	-	0.2	0.4	
Dropout voltage $\Delta V_{OUT}, \Delta V_{REF} = 1\%$	V_D	$V_{IN} = 2.75 - 7V$ $I_O = 10mA - 3A$	$T_J = 25^{\circ}C$	-	1.2	1.4	V
			Over temp.	-	1.3	-	
Current limit	I_S	$V_{IN} = 2.75 - 7V$, Over temp.	3.0	-	-	A	
Temperature Coefficient	T_C	$V_{IN} = 2.75 - 7V$, $I_O = 10mA - 3A$	-	0.005	-	$\%/^{\circ}C$	
Temperature stability	T_S	$V_{IN} = 5V$, $I_O = 500mA$, Over temp.	-	0.5	-	%	
Minimum load current	I_O	$V_{IN} = 5V$	-	5	10	mA	
RMS output noise	V_N	$T_J = 25^{\circ}C$	-	0.003	-	$\%V_O$	
Ripple rejection ratio	R_A	$V_{IN} = 5V$, $I_O = 3A$, Over temp.	60	72	-	dB	

AME1085DXXX

Parameter	Symbol	Test Conditions	Min.	Typ.	Max.	Units	
Output voltage (fixed voltage)	V_O	$V_{IN} = 5V$ $I_O = 0A$	$T_J = 25^{\circ}C$	3.267	3.300	3.333	V
			Over temp.	3.234		3.366	
Line regulation	Reg_{LINE}	$V_{IN} = 4.5 - 7V$ $I_O = 0A$	$T_J = 25^{\circ}C$	-	0.015	0.2	%
			Over temp.	-	0.035	0.2	
Load regulation	Reg_{LOAD}	$V_{IN} = 5V$ $I_O = 0A - 3A$	$T_J = 25^{\circ}C$	-	0.05	0.3	%
			Over temp.	-	0.2	0.4	
Dropout voltage $\Delta V_{OUT}, \Delta V_{REF} = 1\%$	V_D	$V_{IN} = 4.5 - 7V$ $I_O = 0A - 3A$	$T_J = 25^{\circ}C$	-	1.2	1.4	V
			Over temp.	-	1.3	-	
Current limit	I_S	$V_{IN} = 4.5 - 7V$, Over temp.	3.0	-	-	A	
Quiescent current (fixed model)	I_Q	$V_{IN} = 5V$, $I_O = 0A - 3A$, Over temp.	-	12	13	mA	
Temperature Coefficient	T_C	$V_{IN} = 4.5 - 7V$, $I_O = 0A - 3A$	-	0.005	-	$\%/^{\circ}C$	
Temperature stability	T_S	$V_{IN} = 5V$, $I_O = 500mA$, Over temp.	-	0.5	-	%	
RMS output noise	V_N	$T_J = 25^{\circ}C$	-	0.003	-	$\%V_O$	
Ripple rejection ratio	R_A	$V_{IN} = 5V$, $I_O = 3A$, Over temp.	60	72	-	dB	



Application Description

1. Output voltage adjustment

Like most regulators, the AME1085 regulates the output by comparing the output voltage to an internally generated reference voltage. On the adjustable version, the V_{REF} is available externally as 1.25V between V_{OUT} and ADJ. The voltage ratio formed by R1 and R2 should be set to conduct 10mA (minimum output load). The output voltage is given by the following equation:

$$V_{OUT} = V_{REF} \left(1 + \frac{R2}{R1} \right) + I_{ADJ} \times R2$$

On fixed versions of AME1085, the voltage divider is provided internally.

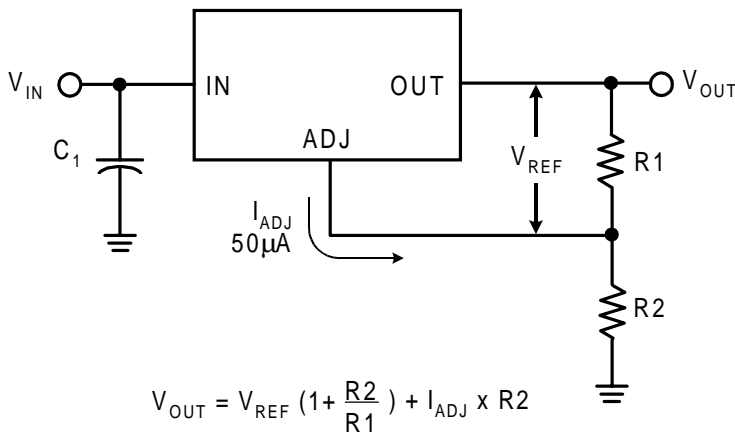

$$V_{OUT} = V_{REF} \left(1 + \frac{R2}{R1} \right) + I_{ADJ} \times R2$$

Figure 3

2. Thermal protection

AME1085 has thermal protection which limits junction temperature to 150°C. However, device functionality is only guaranteed to a maximum junction temperature of +125°C.

The power dissipation and junction temperature for AME1085 in TO-220 package are given by

$$P_D = (V_{IN} - V_{OUT}) \times I_{OUT}$$

$$T_{JUNCTION} = T_{AMBIENT} + (P_D \times \theta_{JA})$$

Note: $T_{JUNCTION}$ must not exceed 125°C

3. Current limit protection

AME1085 is protected against overload conditions. Current protection is triggered at typically 4.5A.

4. Stability and load regulation

AME1085 requires a capacitor from V_{OUT} to GND to provide compensation feedback to the internal gain stage. This is to ensure stability at the output terminal. Typically, a 10µF tantalum or 50µF aluminum electrolytic is sufficient.

Note: It is important that the ESR for this capacitor does not exceed 0.5Ω.

The output capacitor dose not have a theoretical upper limit and increasing its value will increase stability. $C_{OUT} = 100\mu F$ or more is typical for high current regulator design.

For the adjustable version, the best load regulation is accomplished when the top of the resistor divider (R1) is connected directly to the output pin of the AME1085. When so connected, R_p is not multiplied by the divider ratio. For fixed output versions, the top of R1 is internally connected to the output and ground pin can be connected to low side of the load.

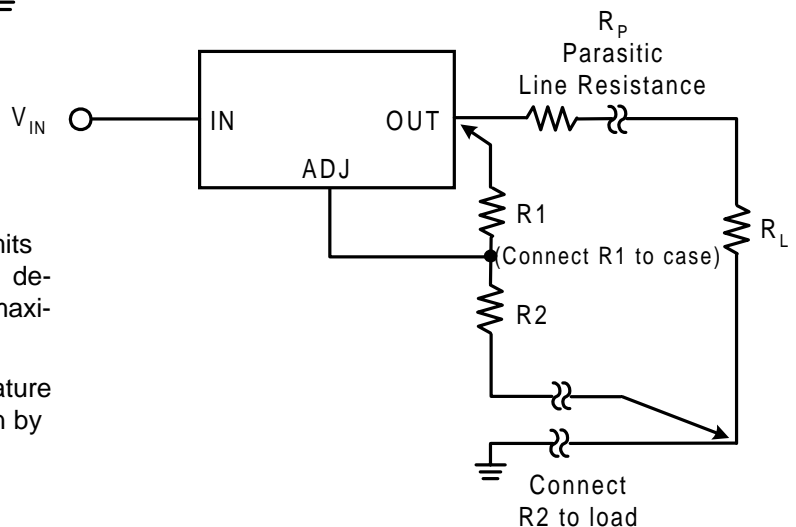

Figure 4



5. Thermal consideration

The AME1085 series contain thermal limiting circuitry designed to protect itself for over-temperature conditions. Even for normal load conditions, maximum junction temperature ratings must not be exceeded. As mentioned in the thermal protection section, we need to consider all sources of thermal resistance between junction and ambient. It includes junction-to-case, case-to-heat-sink interface and heat sink thermal resistance itself.

Junction-to-case thermal resistance is specified from the IC junction to the bottom of the case directly below the die. Proper mounting is required to ensure the best possible thermal flow from this area of the package to the heat sink. The case of all devices in this series is electrically connected to the output. Therefore, if the case of the device must be electrically isolated, a thermally conductive spacer is recommended.



■ Advanced Applications

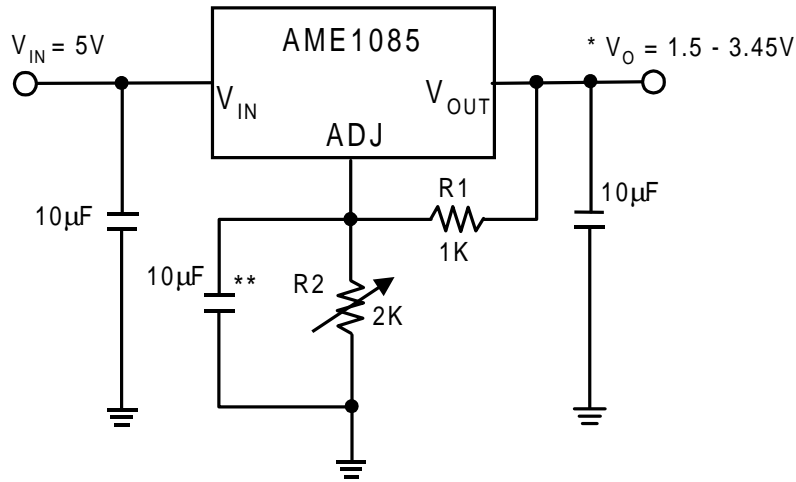

$$* V_O = V_{REF} \left(1 + \frac{R2}{R1} \right) + I_{ADJ} \times R2$$

** Optional for improved ripple rejection

Figure 5 Adjustable output voltage

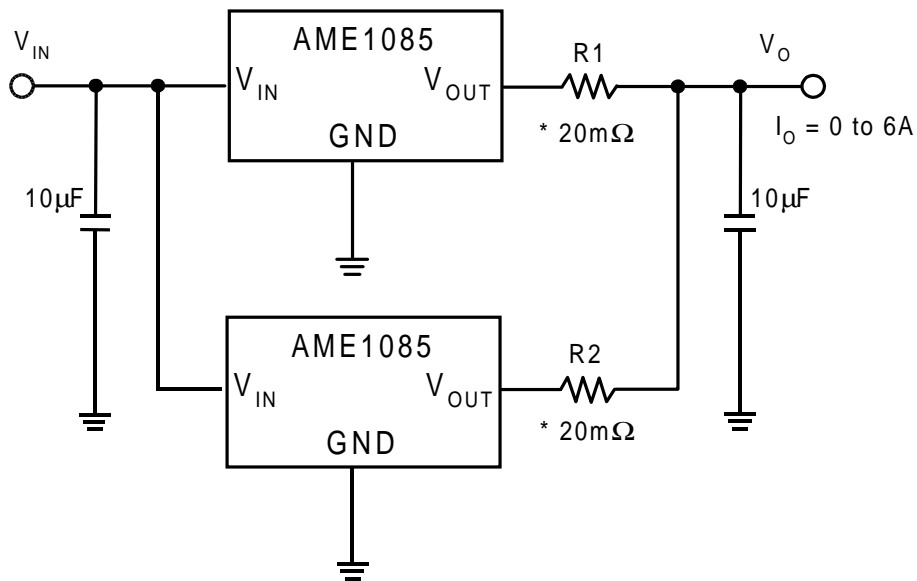

* 20mΩ is ballast resistance

The inter - connection of #18 wire could act as ballast resistance

Figure 6 Paralleling Regulators



■ Advanced Applications (Cont.)

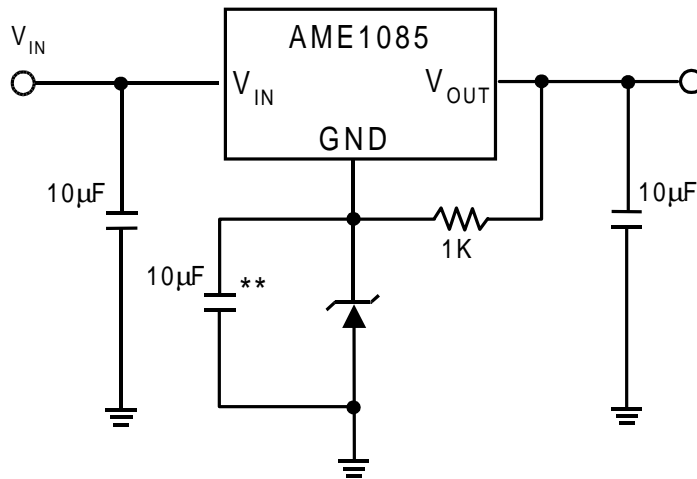

- * $V_O = V_{REF} + V_Z$ (V_Z : breakdown voltage of Zener diode)
- ** Optional for improved ripple rejection

Figure 7 Regulator with reference

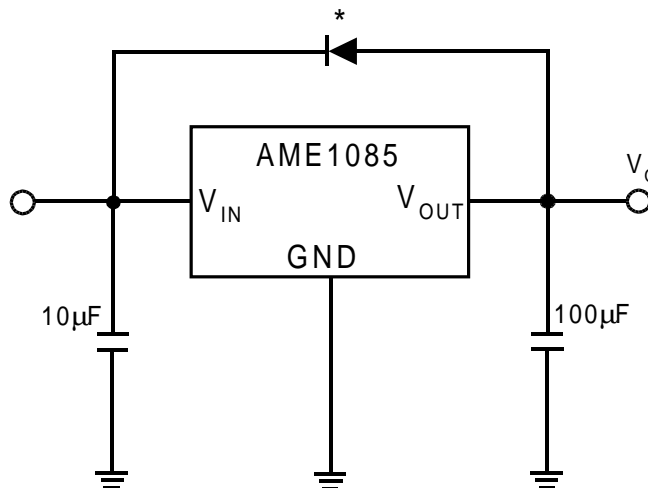

Figure 8 Regulator with reverse diode protection



■ External Resistor Divider Table for Customized Voltage

R1(ohm)	100	102	105	107	110	113	115	118	121	124
Vout	$R2(\text{ohm}) = (V_{\text{out}} - 1.25) * R1 / (1.25 + 50u * R1)$									
1.25	0.000	0.000	0.000	0.000	0.000	0.000	0.000	0.000	0.000	0.000
1.30	3.984	4.063	4.182	4.262	4.381	4.500	4.579	4.698	4.817	4.936
1.35	7.968	8.127	8.365	8.524	8.761	8.999	9.158	9.396	9.633	9.871
1.40	11.95	12.19	12.55	12.79	13.14	13.50	13.74	14.09	14.45	14.81
1.45	15.94	16.25	16.73	17.05	17.52	18.00	18.32	18.79	19.27	19.74
1.50	19.92	20.32	20.91	21.31	21.90	22.50	22.89	23.49	24.08	24.68
1.55	23.90	24.38	25.09	25.57	26.28	27.00	27.47	28.19	28.90	29.61
1.60	27.89	28.44	29.28	29.83	30.67	31.50	32.05	32.88	33.72	34.55
1.65	31.87	32.51	33.46	34.09	35.05	36.00	36.63	37.58	38.53	39.48
1.70	35.86	36.57	37.64	38.36	39.43	40.50	41.21	42.28	43.35	44.42
1.75	39.84	40.63	41.82	42.62	43.81	45.00	45.79	46.98	48.17	49.36
1.80	43.82	44.70	46.01	46.88	48.19	49.50	50.37	51.68	52.98	54.29
1.85	47.81	48.76	50.19	51.14	52.57	54.00	54.95	56.37	57.80	59.23
1.90	51.79	52.82	54.37	55.40	56.95	58.50	59.53	61.07	62.62	64.16
1.95	55.78	56.89	58.55	59.66	61.33	63.00	64.11	65.77	67.43	69.10
2.00	59.76	60.95	62.74	63.93	65.71	67.49	68.68	70.47	72.25	74.03
2.05	63.75	65.01	66.92	68.19	70.09	71.99	73.26	75.17	77.07	78.97
2.10	67.73	69.08	71.10	72.45	74.47	76.49	77.84	79.86	81.88	83.90
2.15	71.71	73.14	75.28	76.71	78.85	80.99	82.42	84.56	86.70	88.84
2.20	75.70	77.21	79.47	80.97	83.23	85.49	87.00	89.26	91.52	93.77
2.25	79.68	81.27	83.65	85.24	87.61	89.99	91.58	93.96	96.33	98.71
2.30	83.67	85.33	87.83	89.50	92.00	94.49	96.16	98.65	101.2	103.6
2.35	87.65	89.40	92.01	93.76	96.38	98.99	100.7	103.4	106.0	108.6
2.40	91.63	93.46	96.20	98.02	100.8	103.5	105.3	108.1	110.8	113.5
2.45	95.62	97.52	100.4	102.3	105.1	108.0	109.9	112.7	115.6	118.5
2.50	99.60	101.6	104.6	106.5	109.5	112.5	114.5	117.4	120.4	123.4
2.55	103.6	105.6	108.7	110.8	113.9	117.0	119.1	122.1	125.2	128.3
2.60	107.6	109.7	112.9	115.1	118.3	121.5	123.6	126.8	130.1	133.3
2.65	111.6	113.8	117.1	119.3	122.7	126.0	128.2	131.5	134.9	138.2
2.70	115.5	117.8	121.3	123.6	127.0	130.5	132.8	136.2	139.7	143.1
2.75	119.5	121.9	125.5	127.9	131.4	135.0	137.4	140.9	144.5	148.1
2.80	123.5	126.0	129.7	132.1	135.8	139.5	141.9	145.6	149.3	153.0
2.85	127.5	130.0	133.8	136.4	140.2	144.0	146.5	150.3	154.1	157.9
2.90	131.5	134.1	138.0	140.6	144.6	148.5	151.1	155.0	159.0	162.9
2.95	135.5	138.2	142.2	144.9	148.9	153.0	155.7	159.7	163.8	167.8
3.00	139.4	142.2	146.4	149.2	153.3	157.5	160.3	164.4	168.6	172.7
3.05	143.4	146.3	150.6	153.4	157.7	162.0	164.8	169.1	173.4	177.7
3.10	147.4	150.3	154.8	157.7	162.1	166.5	169.4	173.8	178.2	182.6



External Resistor Divider Table for Customized Voltage (Cont.)

R1(ohm)	100	102	105	107	110	113	115	118	121	124
Vout	$R2(ohm)=(Vout-1.25)*R1/(1.25+50u*R1)$									
3.15	151.4	154.4	158.9	161.9	166.5	171.0	174.0	178.5	183.0	187.5
3.20	155.4	158.5	163.1	166.2	170.8	175.5	178.6	183.2	187.9	192.5
3.25	159.4	162.5	167.3	170.5	175.2	180.0	183.2	187.9	192.7	197.4
3.30	163.3	166.6	171.5	174.7	179.6	184.5	187.7	192.6	197.5	202.4
3.35	167.3	170.7	175.7	179.0	184.0	189.0	192.3	197.3	202.3	207.3
3.40	171.3	174.7	179.8	183.3	188.4	193.5	196.9	202.0	207.1	212.2
3.45	175.3	178.8	184.0	187.5	192.8	198.0	201.5	206.7	211.9	217.2
3.50	179.3	182.9	188.2	191.8	197.1	202.5	206.1	211.4	216.8	222.1
3.55	183.3	186.9	192.4	196.0	201.5	207.0	210.6	216.1	221.6	227.0
3.60	187.3	191.0	196.6	200.3	205.9	211.5	215.2	220.8	226.4	232.0
3.65	191.2	195.0	200.8	204.6	210.3	216.0	219.8	225.5	231.2	236.9
3.70	195.2	199.1	204.9	208.8	214.7	220.5	224.4	230.2	236.0	241.8
3.75	199.2	203.2	209.1	213.1	219.0	225.0	228.9	234.9	240.8	246.8
3.80	203.2	207.2	213.3	217.3	223.4	229.5	233.5	239.6	245.7	251.7
3.85	207.2	211.3	217.5	221.6	227.8	234.0	238.1	244.3	250.5	256.6
3.90	211.2	215.4	221.7	225.9	232.2	238.5	242.7	249.0	255.3	261.6
3.95	215.1	219.4	225.9	230.1	236.6	243.0	247.3	253.7	260.1	266.5
4.00	219.1	223.5	230.0	234.4	240.9	247.5	251.8	258.4	264.9	271.5
4.05	223.1	227.6	234.2	238.7	245.3	252.0	256.4	263.1	269.7	276.4
4.10	227.1	231.6	238.4	242.9	249.7	256.5	261.0	267.8	274.6	281.3
4.15	231.1	235.7	242.6	247.2	254.1	261.0	265.6	272.5	279.4	286.3
4.20	235.1	239.7	246.8	251.4	258.5	265.5	270.2	277.2	284.2	291.2
4.25	239.0	243.8	250.9	255.7	262.8	270.0	274.7	281.9	289.0	296.1
4.30	243.0	247.9	255.1	260.0	267.2	274.5	279.3	286.6	293.8	301.1
4.35	247.0	251.9	259.3	264.2	271.6	279.0	283.9	291.3	298.6	306.0
4.40	251.0	256.0	263.5	268.5	276.0	283.5	288.5	296.0	303.5	310.9
4.45	255.0	260.1	267.7	272.8	280.4	288.0	293.1	300.7	308.3	315.9
4.50	259.0	264.1	271.9	277.0	284.7	292.5	297.6	305.4	313.1	320.8
4.55	262.9	268.2	276.0	281.3	289.1	297.0	302.2	310.1	317.9	325.7
4.60	266.9	272.2	280.2	285.5	293.5	301.5	306.8	314.8	322.7	330.7
4.65	270.9	276.3	284.4	289.8	297.9	306.0	311.4	319.5	327.5	335.6
4.70	274.9	280.4	288.6	294.1	302.3	310.5	315.9	324.2	332.4	340.6
4.75	278.9	284.4	292.8	298.3	306.7	315.0	320.5	328.8	337.2	345.5
4.80	282.9	288.5	297.0	302.6	311.0	319.5	325.1	333.5	342.0	350.4
4.85	286.9	292.6	301.1	306.8	315.4	324.0	329.7	338.2	346.8	355.4
4.90	290.8	296.6	305.3	311.1	319.8	328.5	334.3	342.9	351.6	360.3
4.95	294.8	300.7	309.5	315.4	324.2	333.0	338.8	347.6	356.4	365.2
5.00	298.8	304.8	313.7	319.6	328.6	337.5	343.4	352.3	361.3	370.2



■ Package Dimension

TO-252 (DPAK) -EIAJ

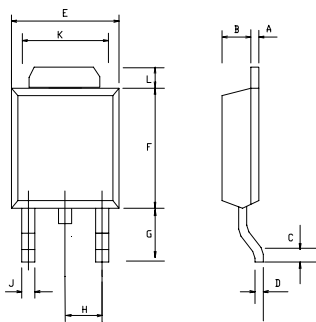

SYMBOLS	MILLIMETERS		INCHES	
	MIN	MAX	MIN	MAX
A	0.45	0.58	0.0177	0.023
B	1.60	1.95	0.06	0.0768
C	0.51	-	0.02	-
D	0.45	0.60	0.0177	0.0236
E	6.40	6.80	0.252	0.2677
F	5.40	5.80	0.2126	0.2283
G	2.20	2.85	0.0866	0.1122
H	-	* 2.30	-	* 0.0906
I	-	0.90	-	0.0354
J	-	0.97	-	0.038
K	5.20	5.50	0.20	0.22
L	0.89	2.03	0.035	0.08

*: Typical value

NOTES :

1. CONTROLLING DIMENSION : MILLIMETERS.
2. MAXIMUM LEAD THICKNESS INCLUDES LEAD FINISH THICKNESS
MINIMUM LEAD THICKNESS IS THE MINIMUM THICKNESS OF BASE MATERIAL.

TO-252 (DPAK) JDEC

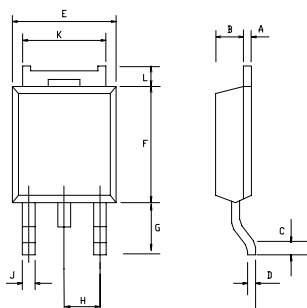

SYMBOLS	MILLIMETERS		INCHES	
	MIN	MAX	MIN	MAX
A	0.45	0.58	0.0177	0.023
B	1.60	1.95	0.06	0.0768
C	0.51	-	0.02	-
D	0.45	0.60	0.0177	0.0236
E	6.40	6.80	0.252	0.2677
F	5.40	5.80	0.2126	0.2283
G	2.20	2.85	0.0866	0.1122
H	-	* 2.30	-	* 0.0906
I	-	0.90	-	0.0354
J	-	0.97	-	0.038
K	5.20	5.50	0.20	0.22
L	0.89	2.03	0.035	0.08

*: Typical value

NOTES :

1. CONTROLLING DIMENSION : MILLIMETERS.
2. MAXIMUM LEAD THICKNESS INCLUDES LEAD FINISH THICKNESS
MINIMUM LEAD THICKNESS IS THE MINIMUM THICKNESS OF BASE MATERIAL.



■ Package Dimension

TO-220

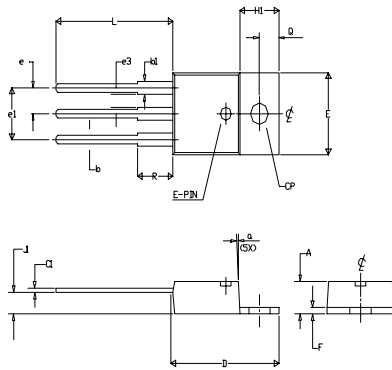

SYMBOLS	MILLIMETERS		INCHES	
	MIN	MAX	MIN	MAX
A	4.06	4.83	0.160	0.190
b	0.63	1.02	0.025	0.040
C1	0.35	0.60	0.0138	0.0236
D	14.22	14.99	0.056	0.590
E	9.66	10.54	0.385	0.415
e	-	2.79	-	0.110
e1	4.83	5.33	0.190	0.210
e3	1.14	1.40	0.045	0.055
f	1.14	1.40	0.045	0.055
H1	5.94	6.55	0.234	0.258
K	2.29	2.92	0.090	0.115
CP	3.71	3.96	0.146	0.156
Q	2.62	2.87	0.103	0.113
L	12.70	14.27	0.500	0.5618
a	3D	7D	3D	7D
b1	1.14	1.52	0.0449	0.06
R	6.17 REF.		0.243 REF.	

Notes :

1. Dimension C1 apply for tin plate finish.
2. For solder dip lead finish dimension C1 should be 0.015"-0.027" (0.38-0.69)

TO-263-3 (D²PAK)

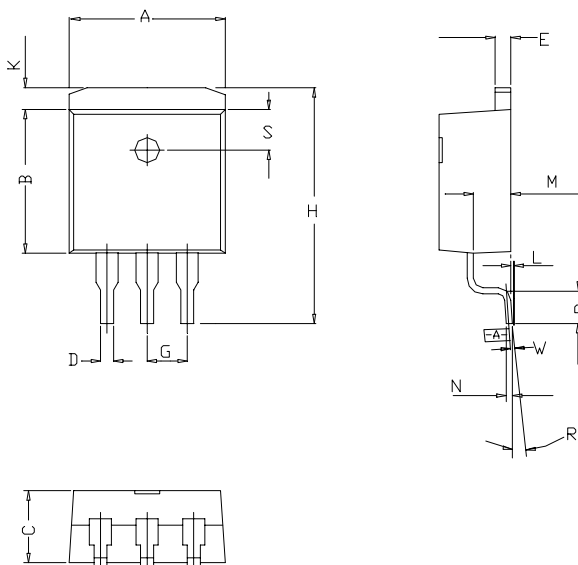

SYMBOLS	MILLIMETERS		INCHES	
	MIN	MAX	MIN	MAX
A	9.65	10.41	0.380	0.410
B	8.28	9.65	0.326	0.380
C	4.06	4.83	0.160	0.190
D	0.51	1.02	0.020	0.040
E	1.14	1.40	0.045	0.055
G	*2.54		*0.100	
H	14.61	15.88	0.575	0.625
K	1.02	1.68	0.040	0.066
L	0.00	0.97	0.000	0.038
M	2.49	2.74	0.098	0.108
N	0.43	0.58	0.017	0.023
P	2.29	2.79	0.090	0.110
R	0°	8°	0°	8°
S	2.41	2.67	0.095	0.105
W	0.254	0.508	0.010	0.020

* : Typical value

NOTES :

1. CONTROLLING DIMENSION : MILLIMETERS.
2. MAXIMUM LEAD THICKNESS INCLUDES LEAD FINISH THICKNESS
MINIMUM LEAD THICKNESS IS THE MINIMUM THICKNESS OF BASE MATERIA.



■ Package Dimension

TO-263-2 (D²PAK)

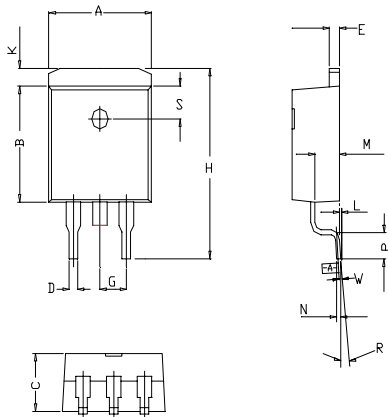

SYMBOLS	MILLIMETERS		INCHES	
	MIN	MAX	MIN	MAX
A	9.65	10.41	0.380	0.410
B	8.28	9.65	0.326	0.380
C	4.06	4.83	0.160	0.190
D	0.51	1.02	0.020	0.040
E	1.14	1.40	0.045	0.055
G	*2.54		*0.100	
H	14.61	15.88	0.575	0.625
K	1.02	1.68	0.040	0.066
L	0.00	0.97	0.000	0.038
M	2.49	2.74	0.098	0.108
N	0.43	0.58	0.017	0.023
P	2.29	2.79	0.090	0.110
R	0°	8°	0°	8°
S	2.41	2.67	0.095	0.105
W	0.254	0.508	0.010	0.020

* : Typical value

NOTES :

1. CONTROLLING DIMENSION : MILLIMETERS.
2. MAXIMUM LEAD THICKNESS INCLUDES LEAD FINISH THICKNESS
MINIMUM LEAD THICKNESS IS THE MINIMUM THICKNESS OF BASE MATERIA.



www.analogmicro.com
E-Mail: info@analogmicro.com

Life Support Policy:

These products of Analog Microelectronics, Inc. are not authorized for use as critical components in life-support devices or systems, without the express written approval of the president of Analog Microelectronics, Inc.

Analog Microelectronics, Inc. reserves the right to make changes in the circuitry and specifications of its devices and advises its customers to obtain the latest version of relevant information.

© Analog Microelectronics, Inc. , July 2001

Document: 1013-duc-B-0704

Corporate Headquarters
Analog Microelectronics, Inc.

3100 De La Cruz Blvd. Suite 201
Santa Clara, CA. 95054-2046
Tel : (408) 988-2388
Fax: (408) 988-2489

Asia Pacific Headquarters
AME, Inc.

2F, 187 Kang-Chien Road, Nei-Hu Dist.,
Taipei 114, Taiwan, R.O.C.
Tel : 886 2 2627-8687
Fax: 886 2 2659-2989