

# AZ DISPLAYS, INC.

*COMPLETE LCD SOLUTIONS*

## ATM4823A-NC-FBD

Date: August 18, 2004



## 1. LCD Module Characteristics

No.	Item	Characteristics	Units
(1)	Module Size	164.9 (W) x 100.0 (H) x 6.7 (D)	mm
(2)	Format	480 x (R.G.B.) x 234	Dots
(3)	Active Area	154.08 (W) x 86.58(H)	mm
(4)	Screen Size (inch)	7.0 (Diagonal)	inch
(5)	Dot Pitch	0.107 (w) x 0.370 (H)	mm
(6)	Weight (g)	160 +/- 10	g
(7)	LCD Type	CSTN (Negative/ Transmissive)	
(8)	Surface treatment	AG (5.5%) with WV film	
(9)	Viewing Direction	6 O'clock	
(10)	Back Light	CCFL	

## B. Electrical specifications

### 1. Pin assignment

#### a. TFT-LCD panel driving section

Pin no	Symbol	I/O	Description	Remark
1	GND	-	Ground for logic circuit	
2	V <sub>CC</sub>	I	Supply voltage of logic control circuit for scan driver	
3	V <sub>GL</sub>	I	Negative power for scan driver	
4	V <sub>GH</sub>	I	Positive power for scan driver	
5	STVR	I/O	Vertical start pulse	Note 1
6	STVL	I/O	Vertical start pulse	Note 1
7	CKV	I	Shift clock input for scan driver	
8	U/D	I	UP/DOWN scan control input	Note 1,2
9	OEV	I	Output enable input for scan driver	
10	VCOM	I	Common electrode driving signal	
11	VCOM	I	Common electrode driving signal	
12	L/R	I	LEFT/RIGHT scan control input	Note 1,2
13	MOD	I	Sequential sampling and simultaneous sampling setting	Note 3
14	OEH	I	Output enable input for data driver	
15	STHL	I/O	Start pulse for horizontal scan line	Note 1
16	STHR	I/O	Start pulse for horizontal scan line	Note 1
17	CPH3	I	Sampling and shifting clock pulse for data driver	
18	CPH2	I	Sampling and shifting clock pulse for data driver	
19	CPH1	I	Sampling and shifting clock pulse for data driver	
20	V <sub>CC</sub>	I	Supply voltage of logic control circuit for data driver	
21	GND	-	Ground for logic circuit	
22	VR	I	Alternated video signal input(Red)	
23	VG	I	Alternated video signal input(Green)	
24	VB	I	Alternated video signal input(Blue)	
25	AV <sub>DD</sub>	I	Supply voltage for analog circuit	
26	AV <sub>SS</sub>	-	Ground for analog circuit	

Note 1: Selection of scanning mode (please refer to the following table)

Setting of scan control input		IN/OUT state for start pulse				Scanning direction
U/D	L/R	STVR	STVL	STHR	STHL	
GND	V <sub>CC</sub>	OUT	IN	OUT	IN	From up to down, and from left to right.
V <sub>CC</sub>	GND	IN	OUT	IN	OUT	From down to up, and from right to left.
GND	GND	OUT	IN	IN	OUT	From up to down, and from right to left.
V <sub>CC</sub>	V <sub>CC</sub>	IN	OUT	OUT	IN	From down to up, and from left to right.

IN: Input; OUT: Output.

Note 2: Definition of scanning direction.  
Refer to figure as below:

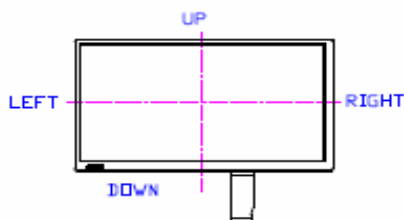

Note 3: MOD = H: Simultaneous sampling.  
MOD = L: Sequential sampling.  
Please set CPH2 and CPH3 to GND when MOD = H.

b. Backlight driving section (Refer to Figure 1)

No.	Symbol	I/O	Description	Remark
1	HI	I	Power supply for backlight unit (High voltage)	--
2	GND	-	Ground for backlight unit	--

2. Absolute maximum ratings

Item	Symbol	Condition	Min.	Max.	Unit	Remark
Power voltage	$V_{CC}$	GND=0	-0.3	7	V	
	$AV_{DD}$	$AV_{SS}=0$	-0.3	7	V	
	$V_{GH}$	GND=0	-0.3	18	V	
	$V_{GL}$		-15	0.3	V	
	$V_{GH}-V_{GL}$		-	33	V	
Input signal voltage	$V_i$		-0.3	$AV_{DD}+0.3$	V	Note 1
	$V_i$		-0.3	$V_{CC}+0.3$	V	Note 2
	VCOM		-2.9	5.2	V	

Note 1: VR, VG, VB.

Note 2: STHL, STHR, OEH, L/R, CPH1~CPH3, STVR, STVL, OEV, CKV, U/D.

### 3. Electrical characteristics

#### a. Typical operating conditions (GND=AVss=0V, Note 4 )

Item	Symbol	Min.	Typ.	Max.	Unit	Remark
Power supply	V <sub>CC</sub>	3	5	5.5	V	
	AV <sub>DD</sub>	4.5	5	5.5	V	
	V <sub>GH</sub>	14.3	15	15.7	V	
	V <sub>GL</sub>	-10.5	-10	-9.5	V	
Video signal amplitude (VR, VG, VB)	V <sub>IA</sub>	0.4	-	AV <sub>DD</sub> -0.4	V	Note 1
	V <sub>iAC</sub>	-	3	-	V	AC component
	V <sub>iDC</sub>	-	AV <sub>DD</sub> /2	-	V	DC component
VCOM	V <sub>CAC</sub>	3.5	5.6	6.5	V <sub>p-p</sub>	AC component, Note 2
	V <sub>CDC</sub>	1.4	1.7	2.0	V	DC component
Input signal voltage	H Level	V <sub>IH</sub>	0.8 V <sub>CC</sub>	-	V <sub>CC</sub>	Note 3
	L Level	V <sub>IL</sub>	0	-	0.2 V <sub>CC</sub>	

Note 1: Refer to Fig.4- (a).

Note 2: The brightness of LCD panel could be changed by adjusting the AC component of VCOM.

Note 3: STHL, STHR, OEH, L/R, CPH1~CPH3, STVR, STVL, OEV, CKV, U/D.

Note 4: Be sure to apply GND, V<sub>CC</sub> and V<sub>GL</sub> to the LCD first, and then apply V<sub>GH</sub>.

#### b. Current consumption (GND=AVss=0V)

Parameter	Symbol	Condition	Min.	Typ.	Max.	Unit	Remark
Current for driver	I <sub>GH</sub>	V <sub>GH</sub> =15V	-	0.20	0.5	mA	
	I <sub>GL</sub>	V <sub>GL</sub> =-10V	-	0.80	1.5	mA	
	I <sub>CC</sub>	V <sub>CC</sub> =5V	-	3.0	6.0	mA	
	I <sub>DD</sub>	AV <sub>DD</sub> =5V	-	17.0	30	mA	

#### c. Backlight driving conditions

Parameter	Symbol	Min.	Typ.	Max.	Unit	Remark
Lamp voltage	V <sub>L</sub>	-	560	620	V <sub>rms</sub>	
Lamp current	I <sub>L</sub>	-	5	7	mArms	
Frequency	F <sub>L</sub>	-	60	80	kHz	Note 4
Lamp starting voltage	V <sub>S</sub>	-	-	900	V <sub>rms</sub>	Note 1,5
		-	-	-	V <sub>rms</sub>	Note 2,5
		-	-	1,100	V <sub>rms</sub>	Note 3,5
Lamp life time		10,000	-	-	Hr	Note 6

Note 1: Ta = 25°C .

Note 2: Ta = 0°C .

Note 3: Ta = -30°C .

Note 4: The lamp frequency should be selected as different as possible from display horizontal synchronous signal to avoid interference.

Note 5: For starting the backlight unit, the output voltage of DC/AC's transformer should be larger than the maximum lamp starting voltage.

Note 6: The" Lamp life time" is defined as the module brightness decrease to 50% original brightness at Ta=25°C , I<sub>L</sub>=6mA.

## 5. AC Timing

### a. Timing conditions

Parameter	Symbol	Min.	Typ.	Max.	Unit.	Remark
Rising time	$t_r$	-	-	10	ns	Note 1
Falling time	$t_f$	-	-	10	ns	Note 1
High and low level pulse width	$t_{CPH}$	99	103	107	ns	CPH1~CPH3
CPH pulse duty	$t_{CWH}$	40	50	60	%	CPH1~CPH3
CPH pulse delay	$t_{C12}$ $t_{C23}$ $t_{C31}$	30	$t_{CPH}/3$	$t_{CPH}/2$	ns	CPH1~CPH3
STH setup time	$t_{SUH}$	20	-	-	ns	STHR,STHL
STH hold time	$t_{HDH}$	20	-	-	Ns	STHR,STHL
STH pulse width	$t_{STH}$	-	1	-	$t_{CPH}$	STHR,STHL
STH period	$t_H$	61.5	63.5	65.5	$\mu s$	STHR,STHL
OEH pulse width	$t_{OEH}$	-	1.22	-	$\mu s$	OEH
Sample and hold disable time	$t_{DIS1}$	-	8.28	-	$\mu s$	
OEV pulse width	$t_{OEV}$	-	5.40	-	$\mu s$	OEV
CKV pulse width	$t_{CKV}$	-	4.18	-	$\mu s$	CKV
Clean enable time	$t_{DIS2}$	-	3.74	-	$\mu s$	
Horizontal display start	$t_{SH}$	-	0	-	$T_{CPH}/3$	
Horizontal display timing range	$t_{DH}$	-	1440	-	$T_{CPH}/3$	
STV setup time	$t_{SUV}$	400	-	-	ns	STVL,STVR
STV hold time	$t_{HDV}$	400	-	-	ns	STVL,STVR
STV pulse width	$t_{STV}$	-	-	1	$t_H$	STVL,STVR
Horizontal lines per field	$t_V$	256	262	268	$t_H$	Note 2
Vertical display start	$t_{SV}$		3	-	$t_H$	
Vertical display timing range	$t_{DV}$		234	-	$t_H$	
VCOM rising time	$t_{rCOM}$		-	5	$\mu s$	
VCOM falling time	$t_{fCOM}$		-	5	$\mu s$	
VCOM delay time	$t_{DCOM}$		-	3	$\mu s$	
RGB delay time	$t_{DRGB}$		-	1	$\mu s$	

Note 1: For all of the logic signals.

Note 2: Please don't use odd horizontal lines to drive LCD panel for both odd and even field simultaneously.

### b. Timing diagram

Please refer to the attached drawing, from Fig.2 to Fig.6.

## 5. Power Sequence

Sequence for power on/off and Signal on/off

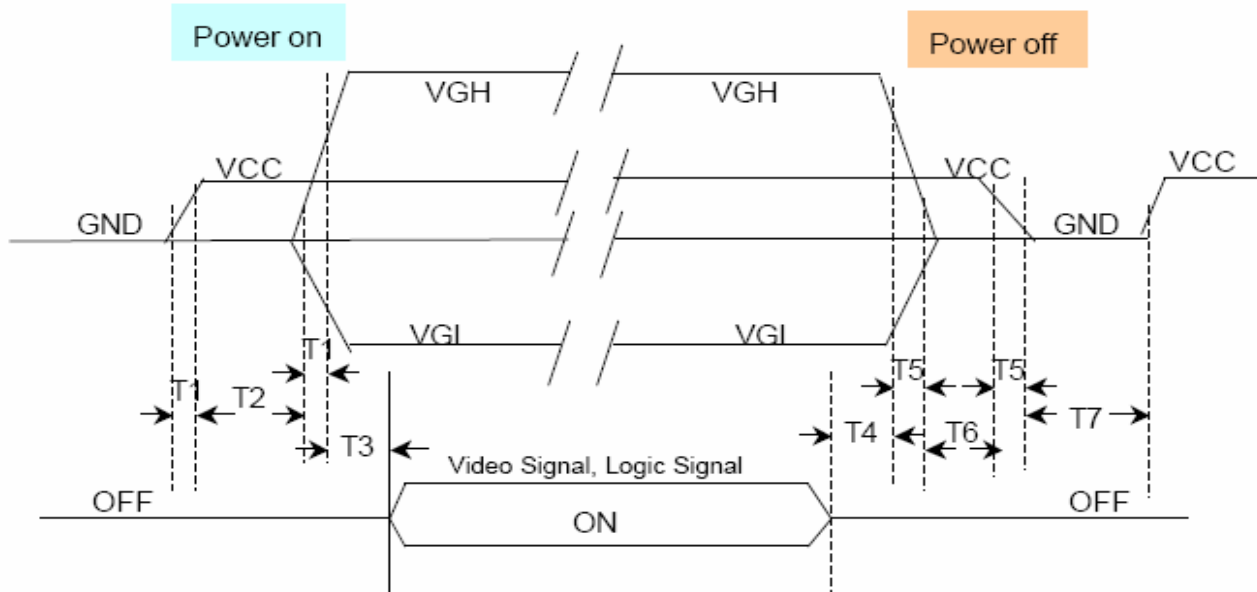

- T1  $\leq$  15ms (From 10%\*VCC to 90%\*VCC , when VCC is Low to High) ;
- T2  $\leq$  10ms (From 90%\*VCC to 10%\*VGH , when VCC is Low to High) ;
- T3  $\leq$  10ms (From 90%\*VGH to Video signal , when VGH is Low to High) ;
- T4  $\leq$  10ms (From Video signal to 90%\*VGH , when VGH is High to Low) ;
- T5  $\leq$  20ms (From 90%\*VCC to 10%\*VCC , when VCC is High to Low) ;
- T6  $\leq$  10ms (From 10%\*VGH to 90%\*VCC , when VCC is Low to High) ;
- T7  $\geq$  0.4s (From 10%\*VCC is H→L to 10%\*VCC is L→H) ◦

## C. Optical specification (Note 1, Note 2)

Item	Symbol	Condition	Min.	Typ.	Max.	Unit	Remark
Response time	Rise	$\theta = 0^\circ$	-	12	50	ms	Note 3,5
	Fall		-	18	60		
Contrast ratio	CR	At optimized Viewing angle	200	300	-		Note 4, 5
Viewing angle	Top	$CR \geq 10$	30	40	-	deg.	Note 5, 6
	Bottom		50	60	-		
	Left		50	60	-		
	Right		50	60	-		
Viewing angle	Top	$CR \geq 5$	30	50	-	deg.	Note 5, 6
	Bottom		60	70	-		
	Left		60	70	-		
	Right		60	70	-		
Brightness	$Y_L$	$I_L = 5mA, 25^\circ C$	350	420	-	$cd/m^2$	Note 7
		$I_L = 6mA, 25^\circ C$	-	500		$cd/m^2$	
White chromaticity	X	$\theta = 0^\circ$	0.26	0.31	0.36		Note 7
	Y	$\theta = 0^\circ$	0.28	0.33	0.38		

Note 1 : Ambient temperature =25°C, and lamp current  $I_L = 6$  mArms. To be measured in the dark room.

Note 2 :To be measured on the center area of panel with a viewing cone of 1° by Topcon luminance meter BM-5, after 10 minutes operation.

Note 3. Definition of response time:

The output signals of photo detector are measured when the input signals are changed from "black" to "white" (falling time) and from "white" to "black" (rising time), respectively.

The response time is defined as the time interval between the 10% and 90% of amplitudes. Refer to figure as below.

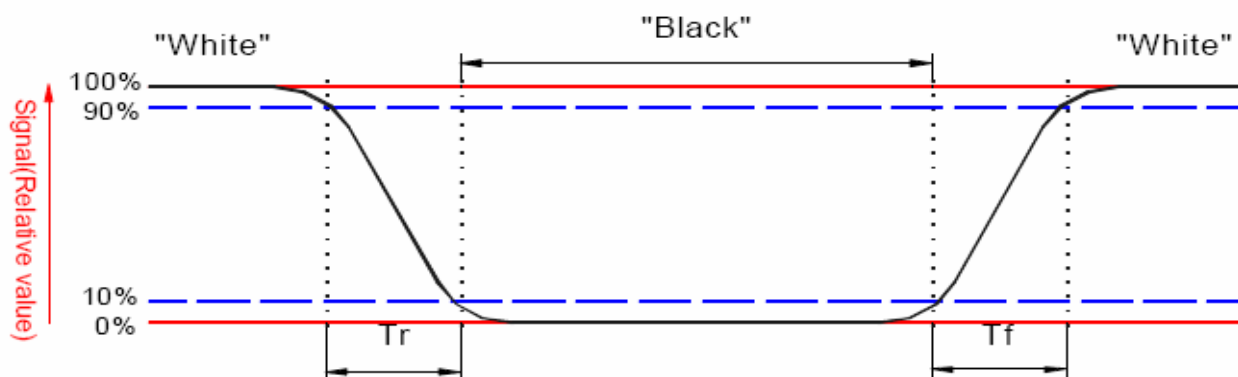

Note 4. Definition of contrast ratio:

Contrast ratio is calculated with the following formula.

$$\text{Contrast ratio (CR)} = \frac{\text{Photo detector output when LCD is at "White" state}}{\text{Photo detector output when LCD is at "Black" state}}$$

Note 5. White  $V_i = V_{i50} + 1.5V$

Black  $V_i = V_{i50} \pm 2.0V$

" $\pm$ " means that the analog input signal swings in phase with  $V_{COM}$  signal.

" $\mp$ " means that the analog input signal swings out of phase with  $V_{COM}$  signal.

$V_{i50}$  : The analog input voltage when transmission is 50%

The 100% transmission is defined as the transmission of LCD panel when all the input terminals of module are electrically opened.

Note 6. Definition of viewing angle, Refer to figure as below.

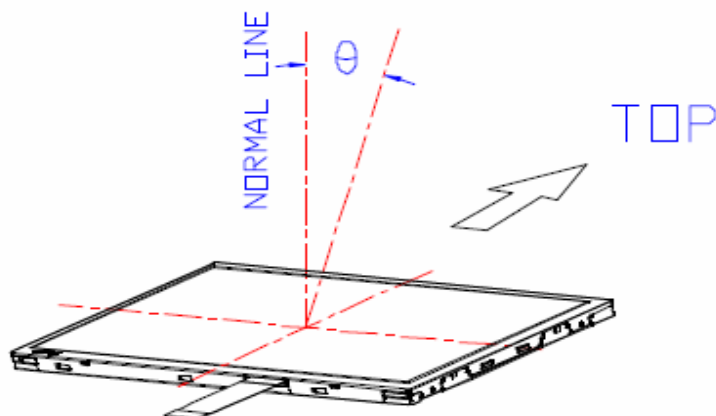

Note 7. Measured at the center area of the panel when all the input terminals of LCD panel are electrically opened.

## D. Reliability test items(Note 2):

No.	Test items	Conditions	Remark
1	High temperature storage	Ta= 95°C 240Hrs	
2	Low temperature storage	Ta= -40°C 240Hrs	
3	High temperature operation	Tp= 85°C 240Hrs	
4	Low temperature operation	Ta= -30°C 240Hrs	
5	High temperature and high humidity	Tp= 60°C, 90% RH 240Hrs	Operation
6	Heat shock	-30°C~85°C/200 cycles 1Hrs/cycle	Non-operation
7	Electrostatic discharge	±200V,200pF(0Ω), once for each terminal	Non-operation
8	Vibration	Frequency range : 8~33.3Hz Stoke : 1.3mm Sweep : 2.9G, 33.3 ~ 400Hz Cycle : 15 minutes 2 hours for each direction of X,Z 4 hours for Y direction	JIS C7021, A-10 Condition A
9	Mechanical shock	100G, 6ms, $\pm X, \pm Y, \pm Z$ 3 times for each direction	JIS C7021, A-7 Condition C
10	Vibration (with carton)	Random vibration: 0.015G <sup>2</sup> /Hz from 5~200Hz -6dB/octave from 200~500Hz	IEC 68-34
11	Drop (with carton)	Height: 60cm 1 corner, 3 edges, 6 surfaces	JIS Z0202

Note1: Ta: Ambient temperature.

Note2: Tp: Panel Surface Temperature

Note3: In the standard conditions, there is not display function NG issue occurred. All the cosmetic specification is judged before the reliability stress.

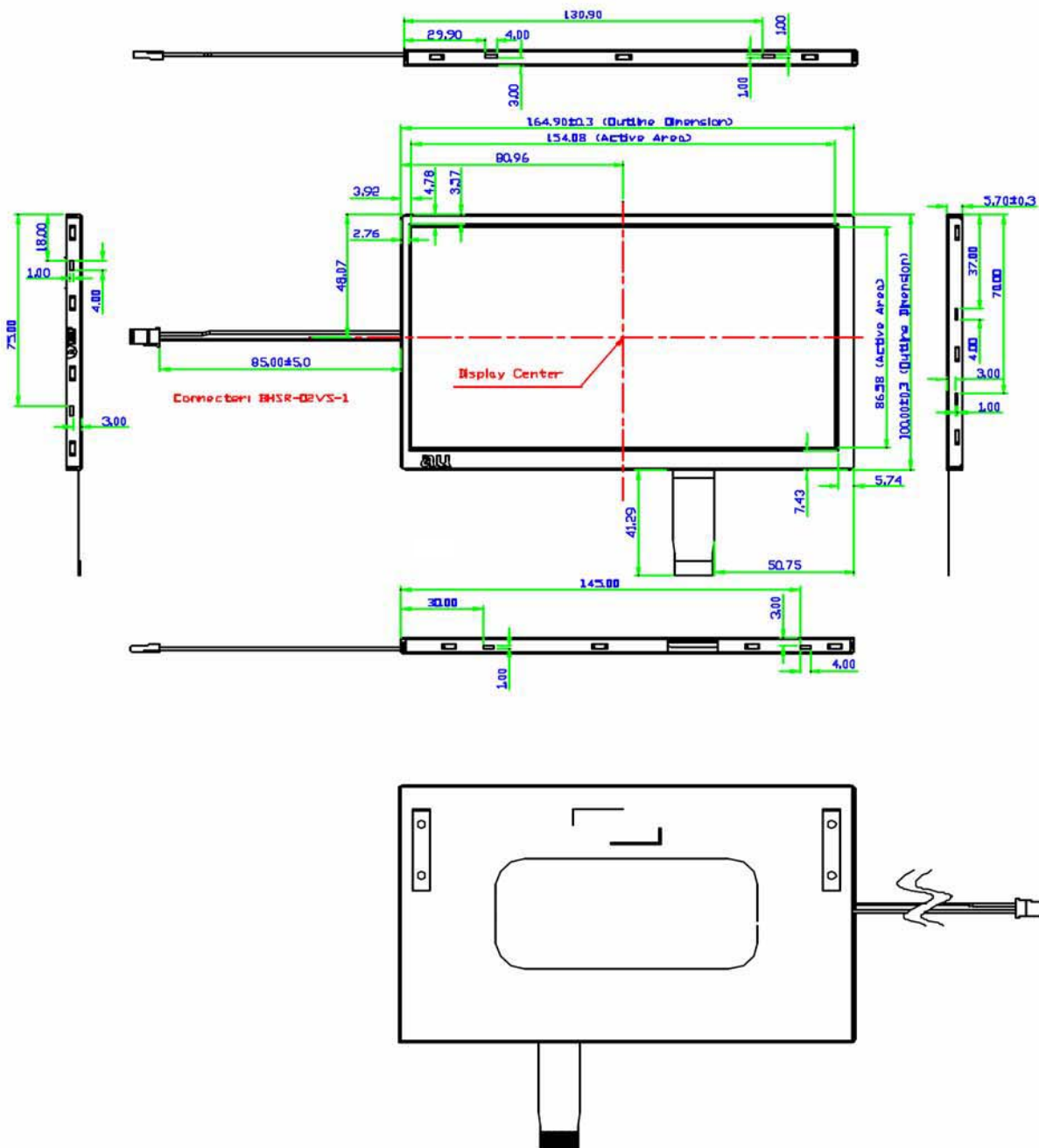

Fig.1- Outline dimension of TFT-LCD module

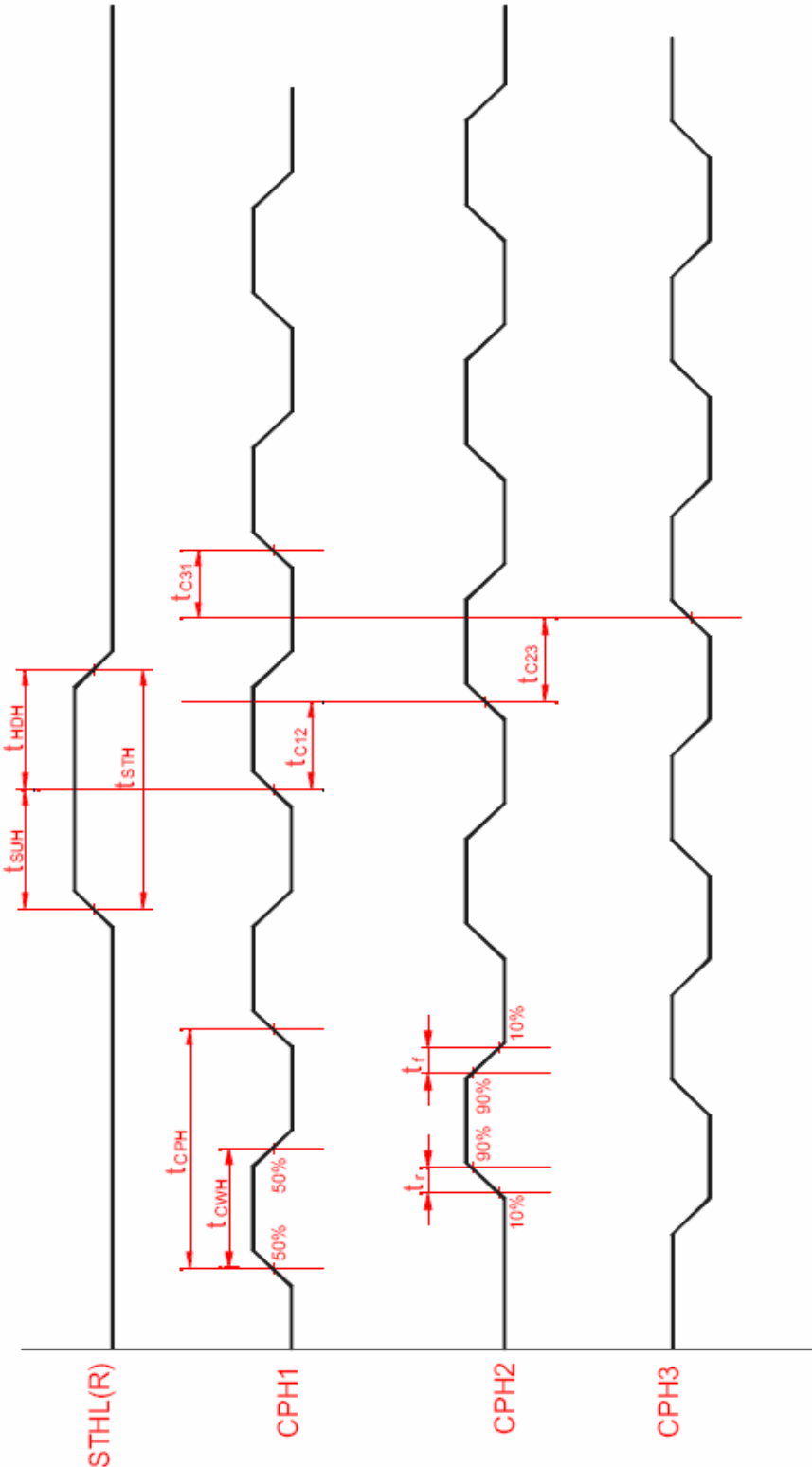

Fig.2 Sampling clock timing

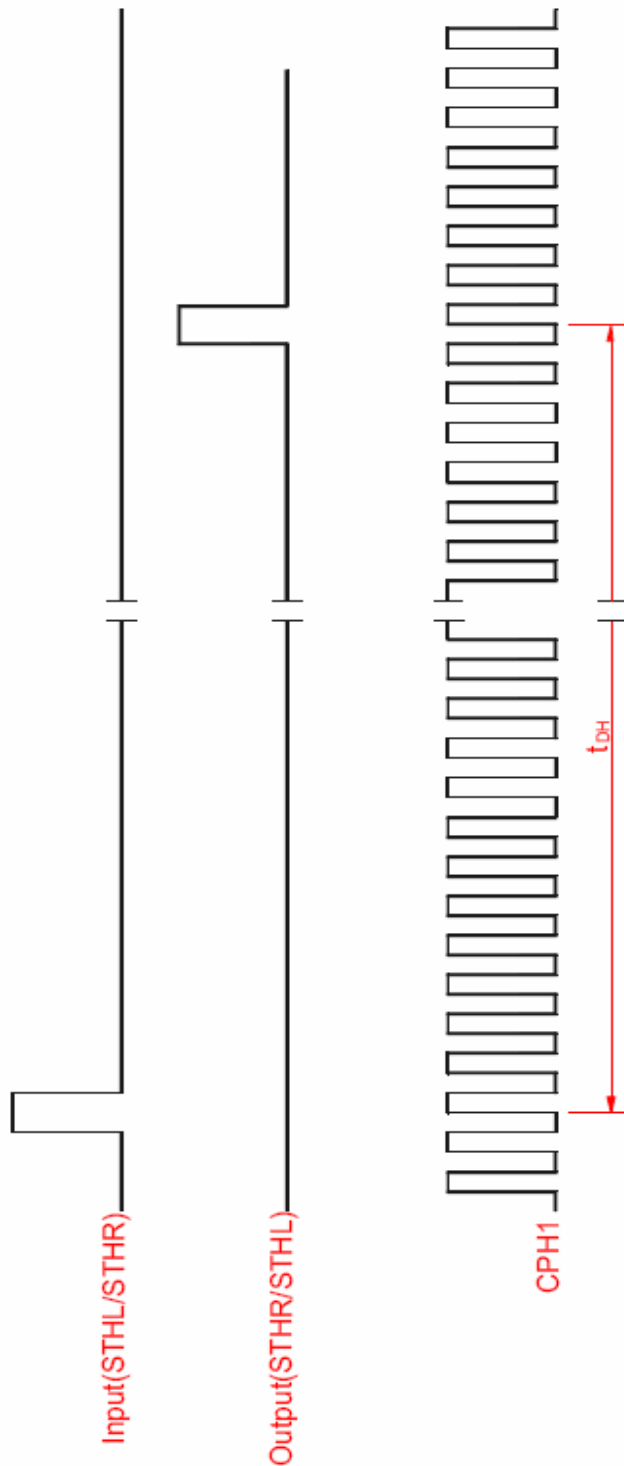

Fig.3 Horizontal display timing range

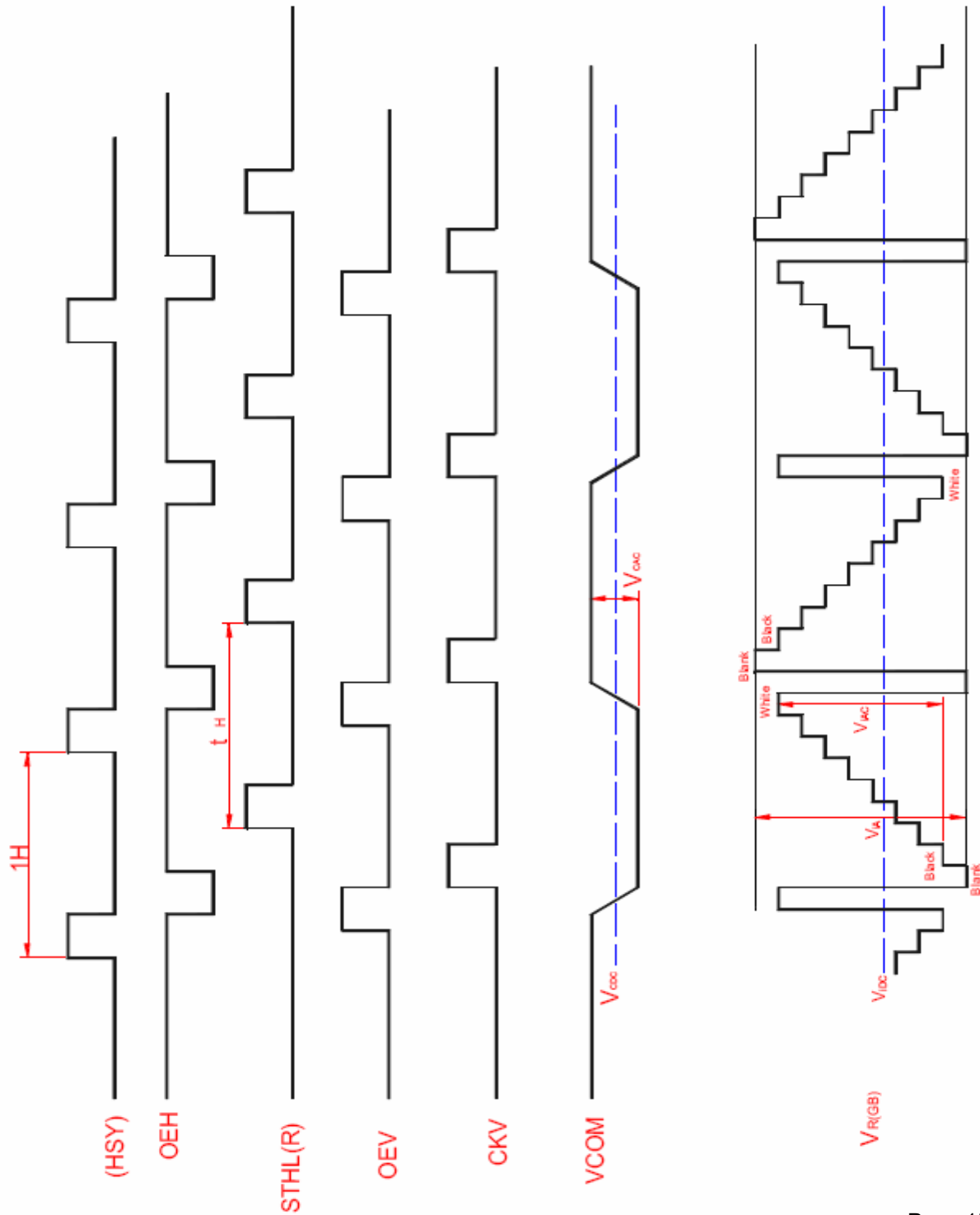

Fig.4-(a) Horizontal timing

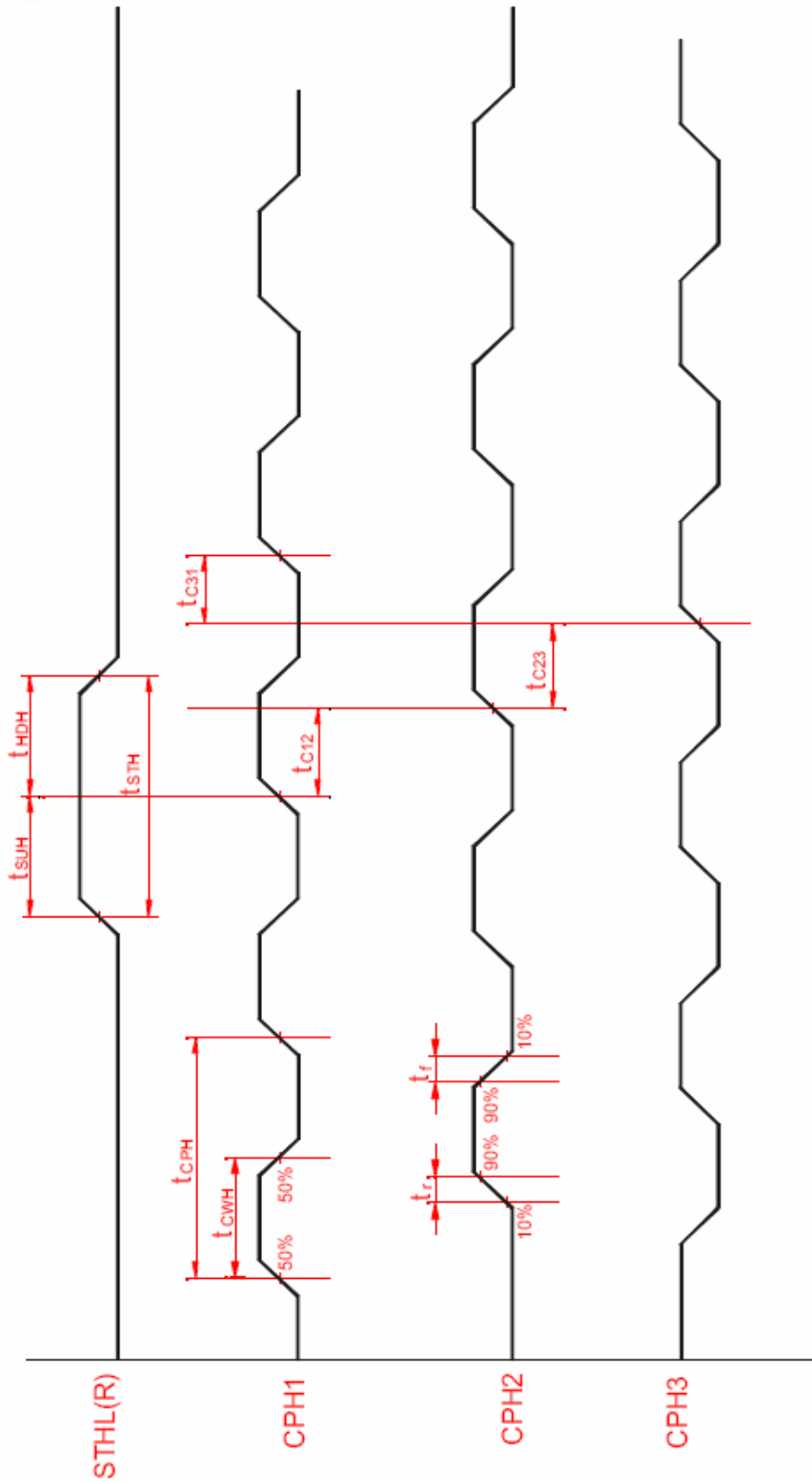

Fig.2 Sampling clock timing

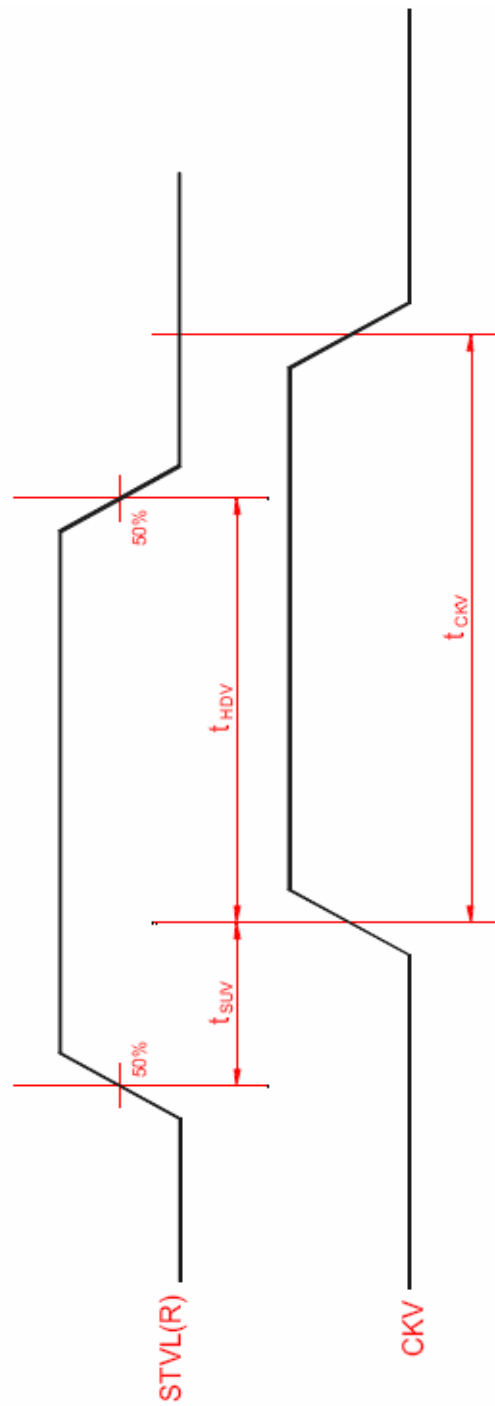

Fig.5 Vertical shift clock timing

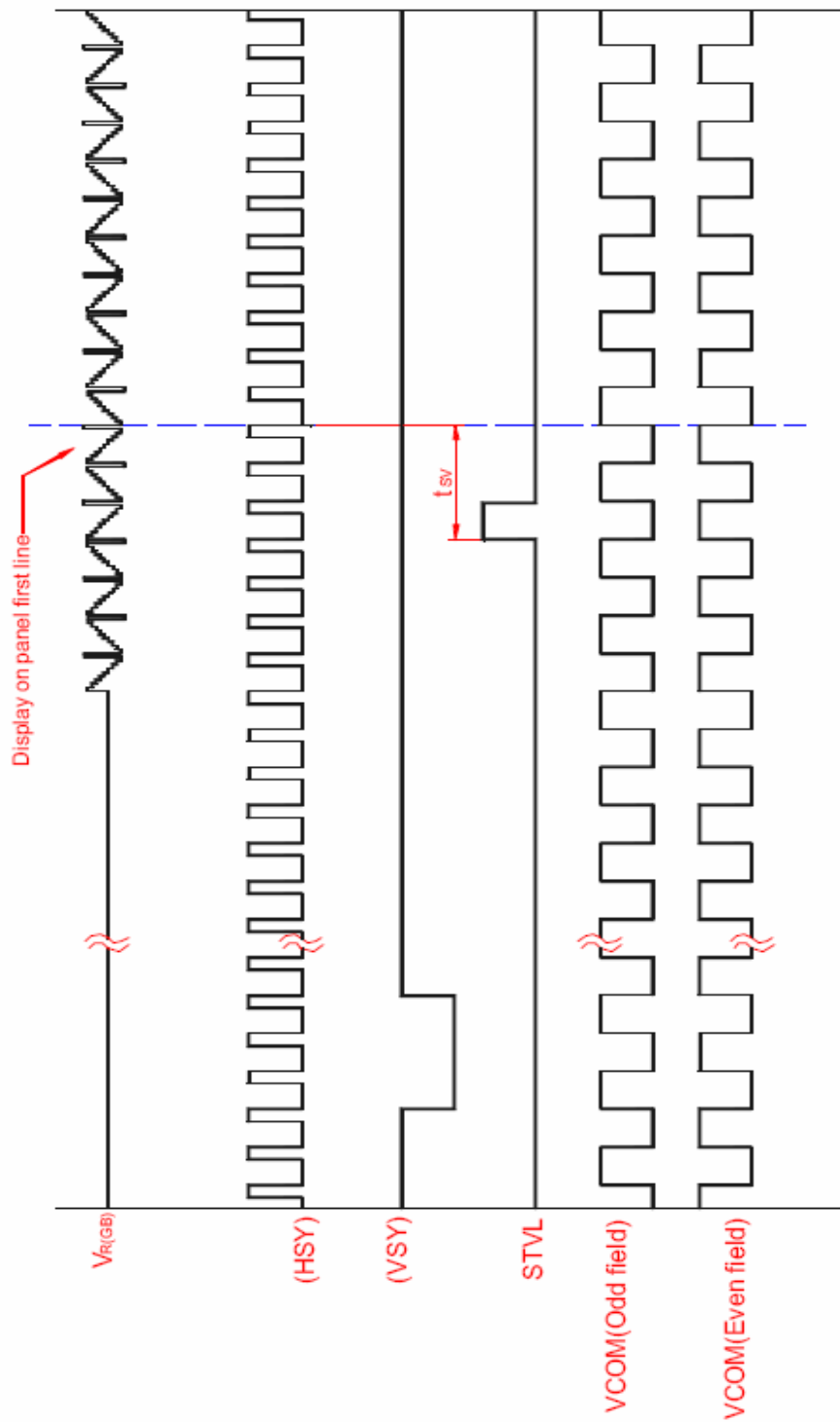

Fig.6-(a) Vertical timing (From up to down)

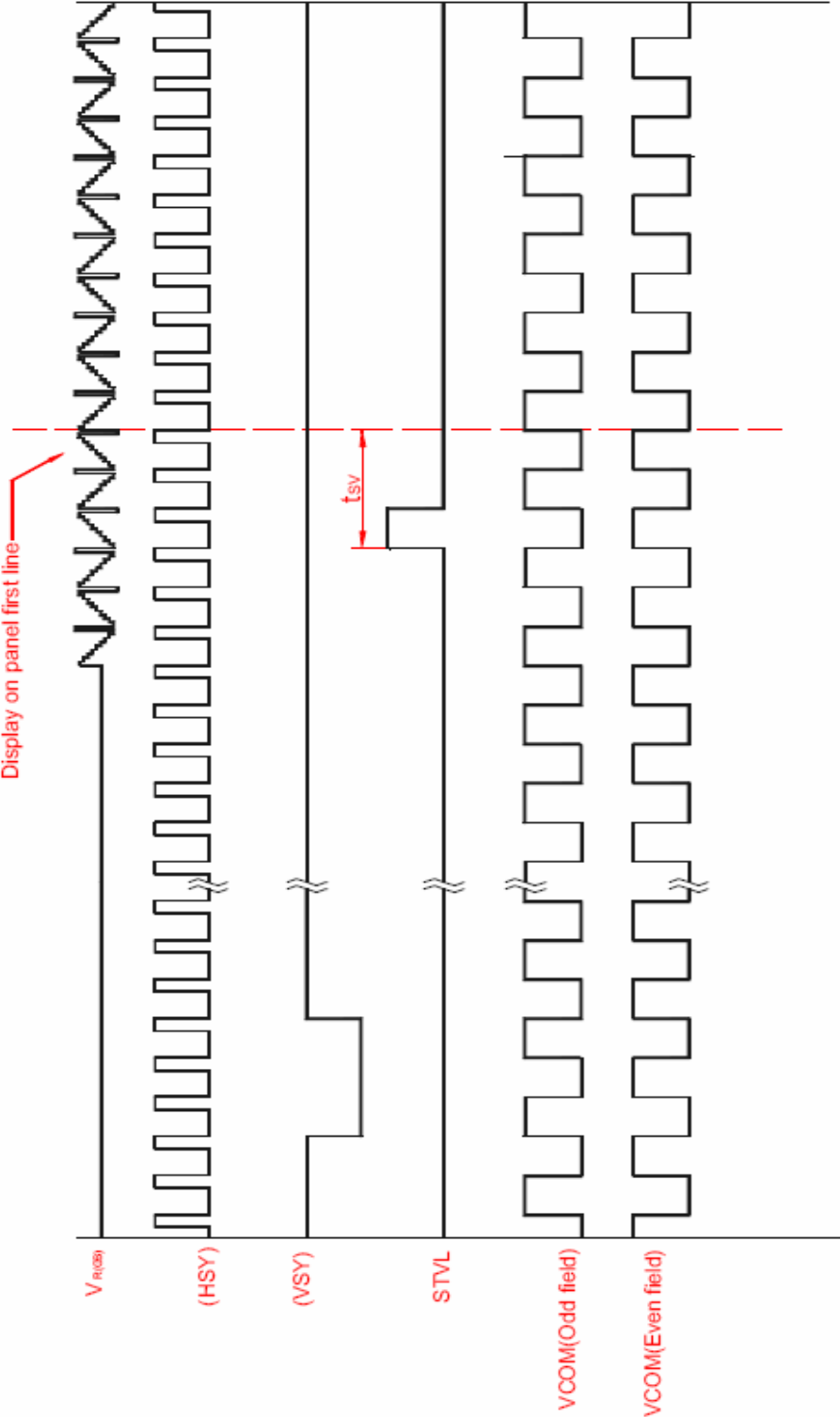

Fig.6-(b) Horizontal timing (From down to up)