

NEC

BIPOLAR ANALOG INTEGRATED CIRCUIT
 μ PC2756TB

**MIXER+OSCILLATOR SILICON MMIC FOR FREQUENCY
 DOWNCONVERTER OF L BAND WIRELESS RECEIVER**

DESCRIPTION

The μ PC2756TB is a silicon monolithic integrated circuit designed as L band frequency downconverter for receiver stage of wireless systems. The IC consists of mixer and local oscillator. The TB suffix IC which is smaller package than conventional T suffix IC contributes to reduce your system size.

The μ PC2756TB is manufactured using NEC's 20GHz fr NESAT™ III silicon bipolar process. This process uses silicon nitride passivation film and gold electrodes. These materials can protect chip surface from external pollution and prevent corrosion/migration. Thus, this IC has excellent performance, uniformity and reliability.

FEATURES

- Wideband operation : $f_{RFin} = 0.1 \text{ GHz to } 2.0 \text{ GHz}$, $f_{IFout} = 10 \text{ MHz to } 300 \text{ MHz}$
- High-density surface mounting : 6-pin super mini mold package
- Low current consumption : $I_{CC} = 6.0 \text{ mA TYP. @ } V_{CC} = 3.0 \text{ V}$
- Supply voltage : $V_{CC} = 2.7 \text{ to } 3.3 \text{ V}$
- Suppressed spurious signals : Due to double balanced mixer
- Equable output impedance : Single-end push-pull IF amplifier
- Equable temperature-drift oscillator : Differential amplifier type oscillator

APPLICATIONS

- Data carrier up to 2.0 GHz MAX.
- Wireless LAN up to 2.0 GHz MAX.

ORDERING INFORMATION

Part Number	Marking	Package	Supplying Form
μ PC2756TB-E3	C1W	6-pin super minimold	Embossed tape 8mm wide. Pin1, 2, 3 face to tape perforation side. QTY 3kp/reel.

Remark To order evaluation samples, please contact your local NEC sales office.
 (Part number for sample order: μ PC2756TB)

Caution Electro-static sensitive devices.

The information in this document is subject to change without notice.

PIN CONNECTIONS

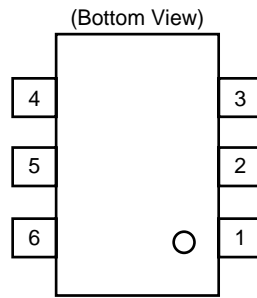
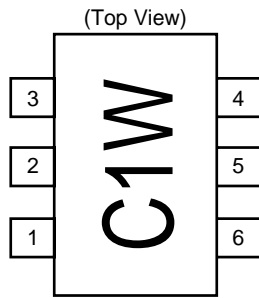

Pin No.	Pin Name
1	RF _{in}
2	GND
3	LO ₁
4	LO ₂
5	V _{cc}
6	IF _{out}

PRODUCT LINE-UP (T_A = +25 °C, V_{CC} = 3.0 V, Z_L = Z_S = 50 Ω)

Items Part Number	V _{cc} (V)	I _{cc} (mA)	900 MHz CG (dB)	1.6 GHz CG (dB)	900 MHz NF (dB)	1.6 GHz NF (dB)	f _{RFIn} (GHz)	f _{IFout} (GHz)	f _{osc} (GHz)	Package
μPC2756T	2.7 to 3.3	6.0	14	14	10	13	0.1 to 2.0	10 to 300	to 2.2	6-pin minimold
μPC2756TB										6-pin super minimold

Remark Typical performance. Please refer to ELECTRICAL CHARACTERISTICS in detail.

INTERNAL BLOCK DIAGRAM

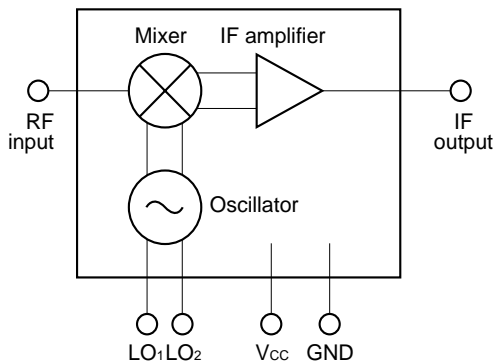

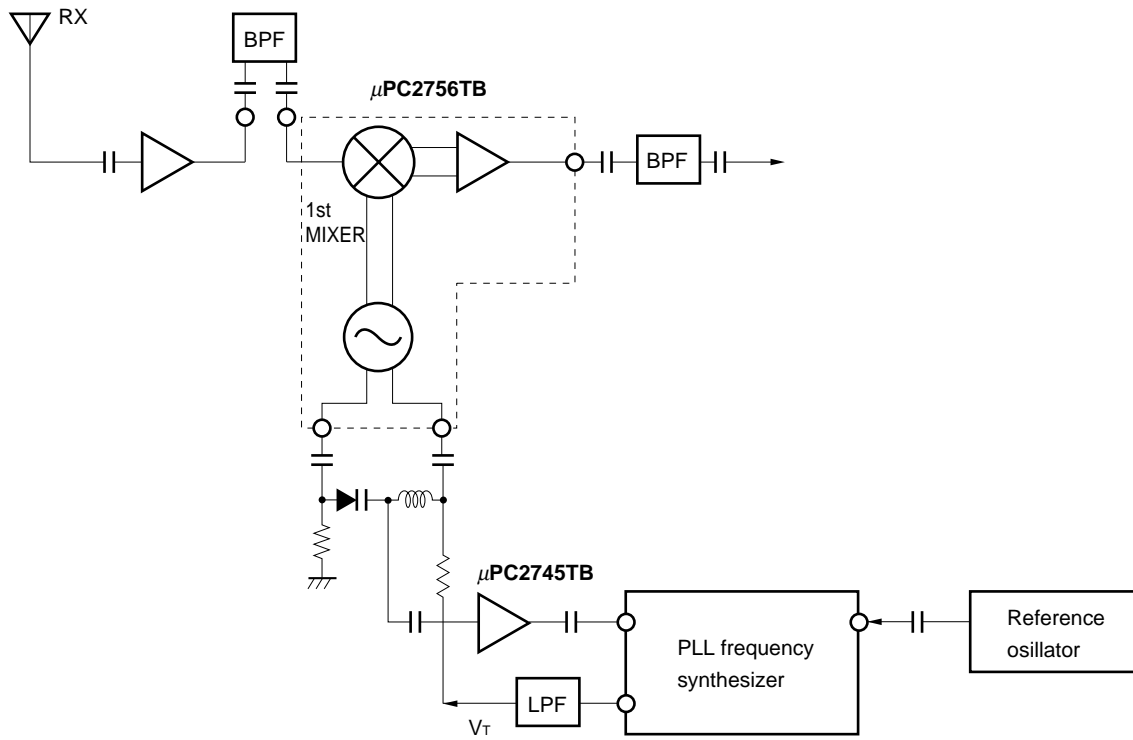

Note Oscillator tank circuit must be externally attached to LO₁ and LO₂ pins.

μ PC2756TB LOCATION EXAMPLE IN THE SYSTEM

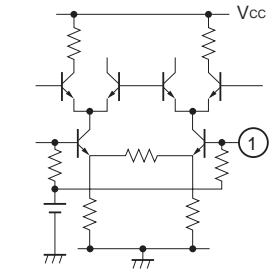
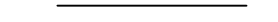
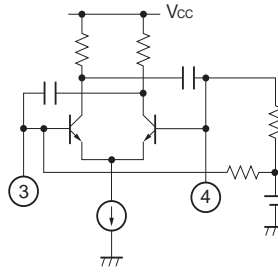

This document is to be specified for μ PC2756TB. For the other part number mentioned in this document, please refer to the data sheet of each part number.

PIN EXPLANATION

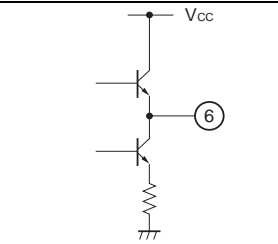
Pin No.	Symbol	Assignment	Applied Voltage V	Pin Voltage V ^{Note}	Function and Application	Equivalent Circuit
1	RF _{in}	RF input	–	1.2	This pin is RF input for mixer designed as double balance type. This circuit contributes to suppress spurious signal with minimum LO and bias power consumption. Also this symmetrical circuit can keep specified performance insensitive to process-condition distribution. This pin must be externally coupled to front stage with capacitor for DC cut.	
2	GND	Ground	0	–	Must be connected to the system ground with minimum inductance. Ground pattern on the board should be formed as wide as possible. (Track length should be kept as short as possible.)	
3	LO ₁	Local oscillator base collector	–	1.2	These pins are both base-collector of oscillator. This oscillator is designed as differential amplifier type. 3 pin and 4 pin should be externally equipped with tank resonator circuit in order to oscillate with feedback loop. Also this symmetrical circuit can keep specified performance insensitive to process-condition distribution. Each pin must be externally coupled to tank circuit with capacitor for DC cut.	
4	LO ₂	Local oscillator base collector	–	1.2		
5	V _{cc}	Power supply	2.7 to 3.3	–	Supply voltage 3.0 ± 0.3 V for operation. Must be connected bypass capacitor (e.g. 1 000 pF) to minimize ground impedance.	
6	IF out	IF output	–	1.7	This pin is output from IF buffer amplifier designed as single-ended push-pull type. This pin is assigned for emitter follower output with low-impedance. This pin must be externally coupled to next stage with capacitor for DC cut.	

Note Pin voltage is measured at V_{cc} = 3.0 V

APPLICATION

This IC is guaranteed on the test circuit constructed with 50 Ω equipment and transmission line. This IC, however, does not have 50 Ω input/output impedance, but electrical characteristics such as conversion gain and intermodulation distortion are described herein on these conditions without impedance matching. So, you should understand that conversion gain and intermodulation distortion at input level will vary when you improve V_S of RF input with external circuit (50 Ω termination or impedance matching).

External circuits of the IC are explained in a following application note.

- To RF and IF port: Application Note “Usage and Application Characteristics of μPC2757T, μPC2758T and μPC8112T, 3-V Power Supply, 1.9-GHz Frequency Down Converter ICs for Cellular/Cordless Telephone and Portable Wireless Communication” (Document No. P11997E)

ABSOLUTE MAXIMUM RATINGS

Parameter	Symbol	Conditions	Rating	Unit
Supply Voltage	V _{CC}	T _A = +25 °C	5.5	V
Power Dissipation	P _D	Mounted on double sided copper clad 50 × 50 × 1.6 mm epoxy glass PWB (T _A = +85 °C)	200	mW
Operating Ambient Temperature	T _A		-40 to +85	°C
Storage Temperature	T _{stg}		-55 to +150	°C

RECOMMENDED OPERATING RANGE

Parameter	Symbol	MIN.	TYP.	MAX.	Unit
Supply Voltage	V _{CC}	2.7	3.0	3.3	V
Operating Ambient Temperature	T _A	-40	+25	+85	°C

ELECTRICAL CHARACTERISTICS (T_A = +25 °C, V_{CC} = 3.0 V, Z_L = Z_s = 50 Ω, Test circuit)

Parameter	Symbol	Conditions	MIN.	TYP.	MAX.	Unit
Circuit Current	I _{CC}	No input signals	3.5	6.0	8.0	mA
RF Frequency Response	f _{RFin}	CG ≥ (CG1 -3 dB) f _{IFout} = 150 MHz constant	0.1	-	2.0	GHz
IF Frequency Response	f _{IFout}	CG ≥ (CG1 -3 dB) f _{RFin} = 0.9 GHz constant	10	-	300	MHz
Conversion Gain 1	CG1	f _{RFin} = 0.9 GHz, f _{IFout} = 150 MHz P _{RFin} = -40 dBm	11	14	17	dB
Conversion Gain 2	CG2	f _{RFin} = 1.6 GHz, f _{IFout} = 20 MHz P _{RFin} = -40 dBm	11	14	17	dB
Single Sideband Noise Figure 1	NF1	f _{RFin} = 0.9 GHz, f _{IFout} = 150 MHz	-	10	13	dB
Single Sideband Noise Figure 2	NF2	f _{RFin} = 1.6 GHz, f _{IFout} = 20 MHz	-	13	16	dB
Maximum IF Output Level 1	P _{O(SAT)1}	f _{RFin} = 0.9 GHz, f _{IFout} = 150 MHz P _{RFin} = -10 dBm	-11	-8	-	dBm
Maximum IF Output Level 2	P _{O(SAT)2}	f _{RFin} = 1.6 GHz, f _{IFout} = 20 MHz P _{RFin} = -10 dBm	-15	-12	-	dBm

STANDARD CHARACTERISTICS FOR REFERENCE (Unless otherwise specified, T_A = +25 °C, V_{CC} = 3.0 V, Z_L = Z_s = 50 Ω)

Parameter	Symbol	Conditions	Reference	Unit
Output 3rd Order Intercept Point	OIP ₃	f _{RFin} = 0.8 to 2.0 GHz, f _{IFout} = 0.1 GHz, Cross point IP.	+4.0	dBm
Phase Noise	PN	f _{OSC} = 1.9 GHz ^{Note}	-68	dBc/Hz
LO Leakage at RF Pin	LO _{rf}	f _{LOin} = 0.8 to 2.0 GHz	-35	dB
LO Leakage at IF Pin	LO _{if}	f _{LOin} = 0.8 to 2.0 GHz	-23	dB
Maximum Oscillating Frequency	f _{OSCMAX}	VaractorDi: 1SV210, L: 7 nH ^{Note}	2.2	GHz

Note On application circuit example.

★ SCHEMATIC SUPPLEMENT FOR RF, IF SPECIFICATIONS

RF Frequency Response

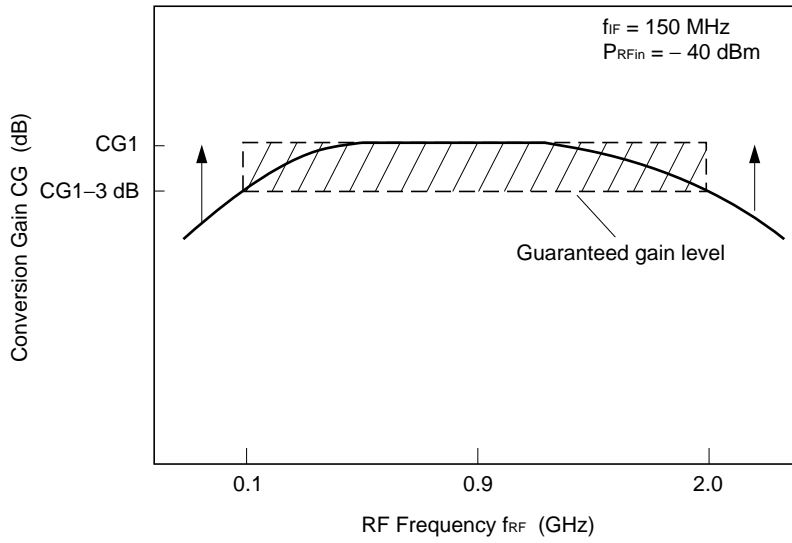

	MIN.	TYP.	MAX.	Unit
CG1	11	14	17	dB
CG1-3 dB	8	11	14	dB

IF Frequency Response

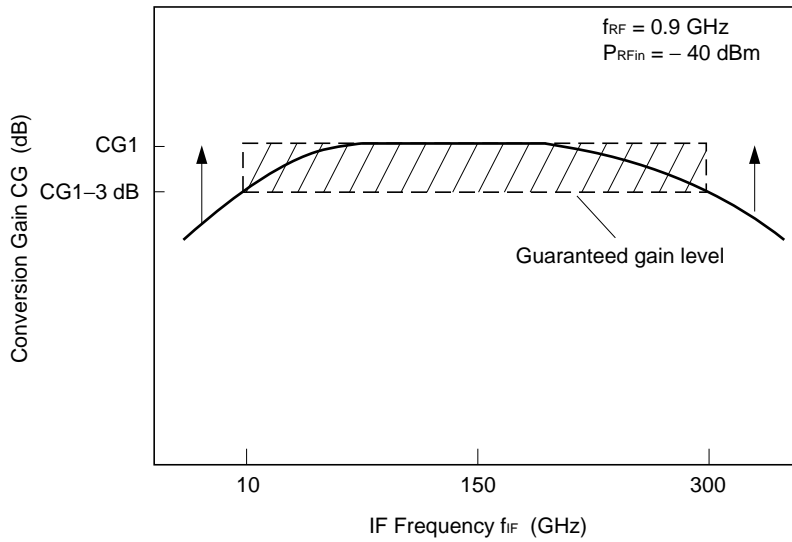

★ TEST CIRCUIT

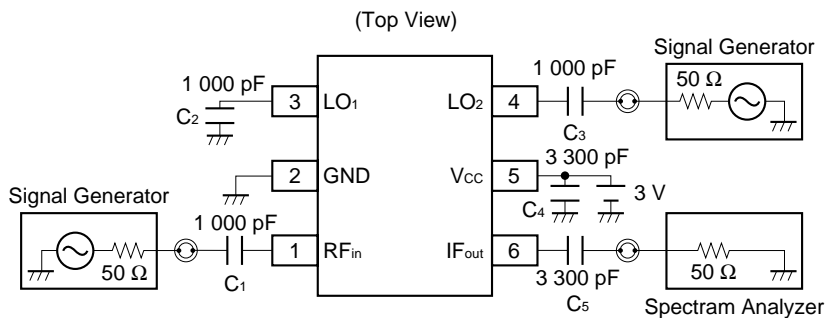

★ ILLUSTRATION OF THE TEST CIRCUIT ASSEMBLED ON EVALUATION BOARD

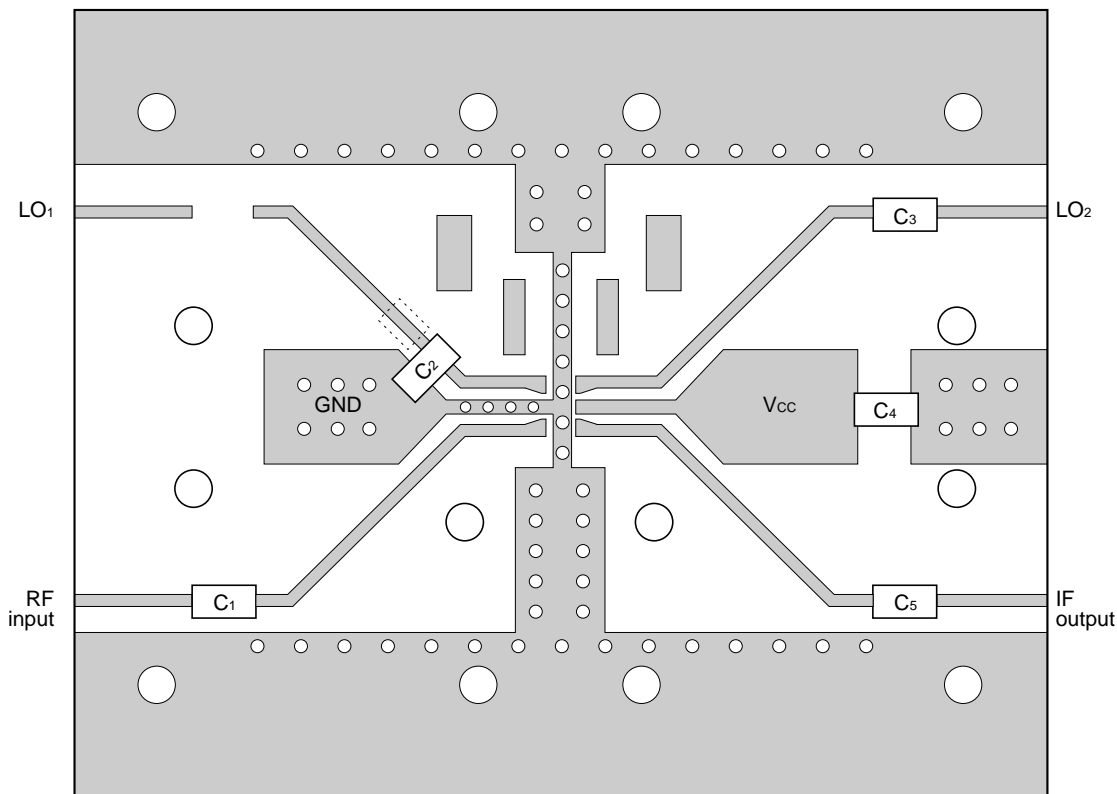

COMPONENT LIST

No.	Value
C ₁ to C ₃	1 000 pF
C ₄ , C ₅	3 300 pF

Notes

- (1) 35 × 42 × 0.4 mm double copper clad polyimide board.
- (2) Back side: GND pattern
- (3) Solder plated on pattern
- (4) ○: Through holes
- (5) [dashed box] pattern should be removed on this testing.

★ APPLICATION CIRCUIT EXAMPLE

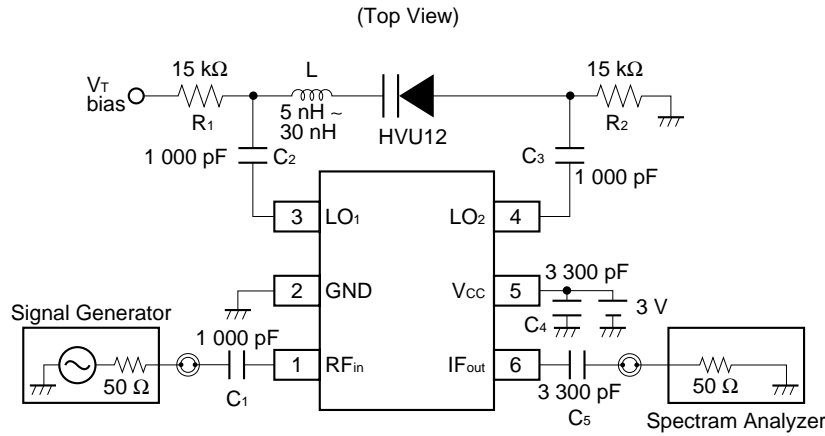

★ ILLUSTRATION OF THE APPLICATION CIRCUIT ASSEMBLED ON EVALUATION BOARD

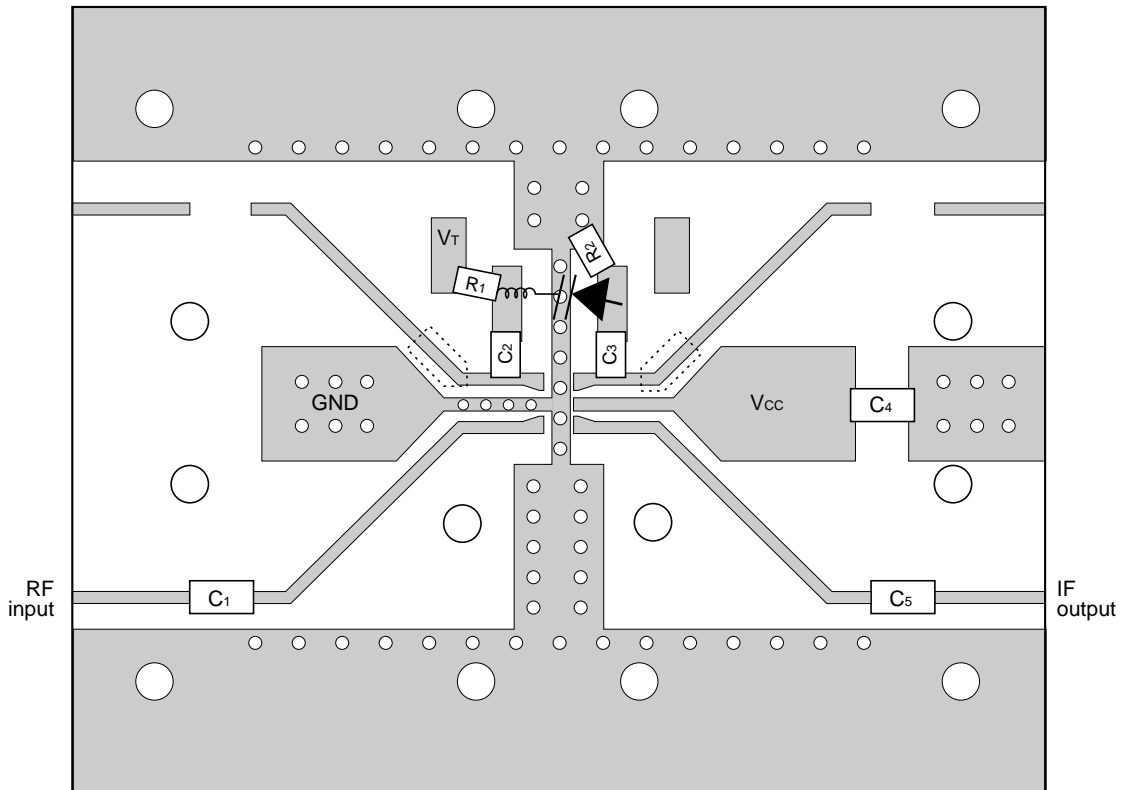

COMPONENT LIST

No.	Value
C ₁ to C ₃	1 000 pF
C ₄ , C ₅	3 300 pF
R ₁ , R ₂	15 kΩ
L	5 nH to 30 nH
HVU12	—

Notes

- (1) 35 × 42 × 0.4 mm double copper clad polyimide board.
- (2) Back side: GND pattern
- (3) Solder plated on pattern
- (4) ○ : Through holes
- (5) [dashed pattern] : pattern should be removed on this testing.

The application circuits and their parameters are for reference only and are not intended for use in actual design-ins.

★ TYPICAL CHARACTERISTICS ($T_A = +25\text{ }^\circ\text{C}$)

– ON THE TEST CIRCUIT –

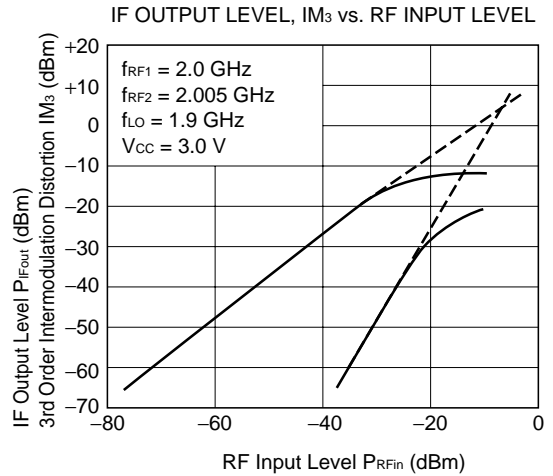
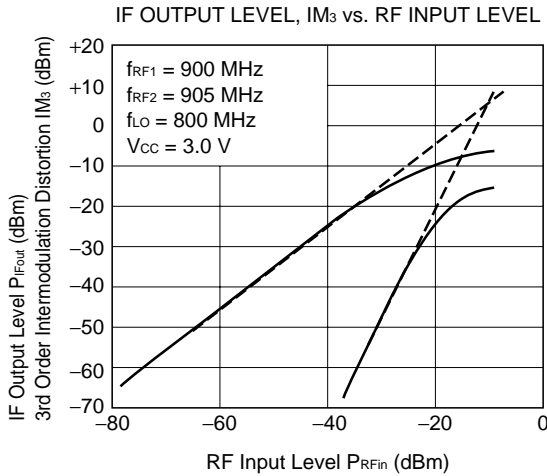
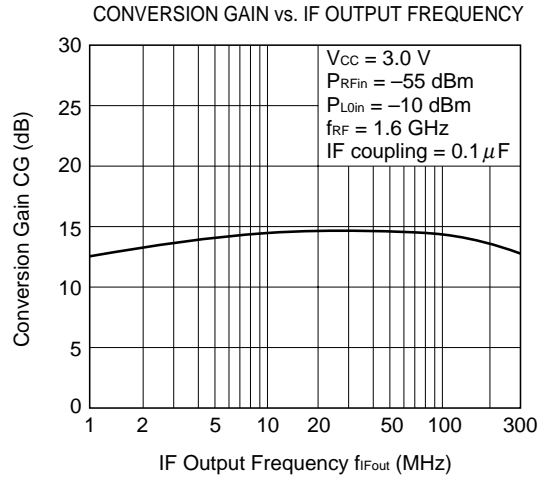
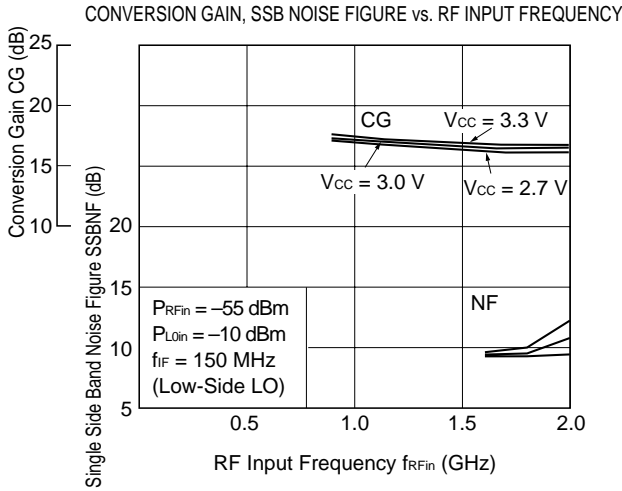
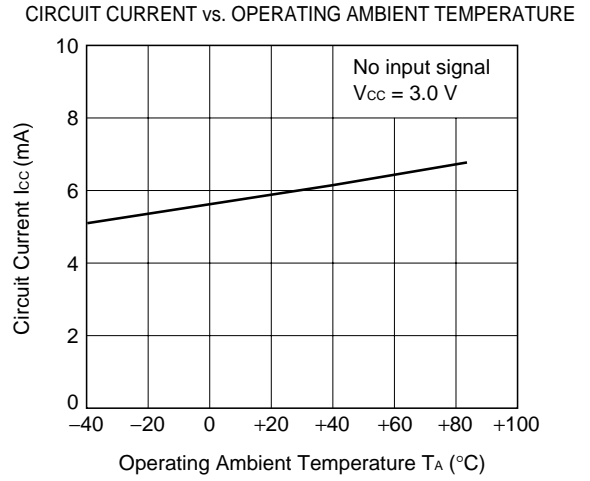
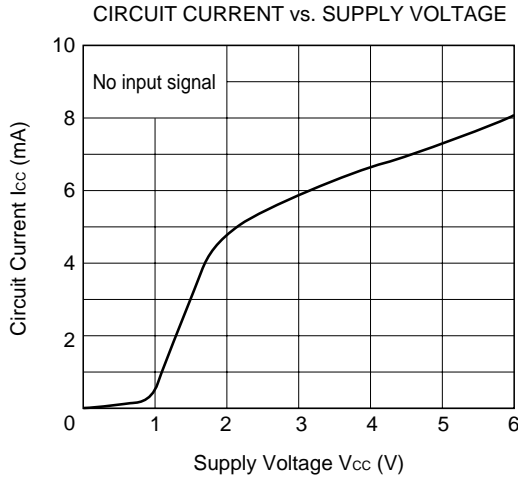

★ – ON THE APPLICATION CIRCUIT –

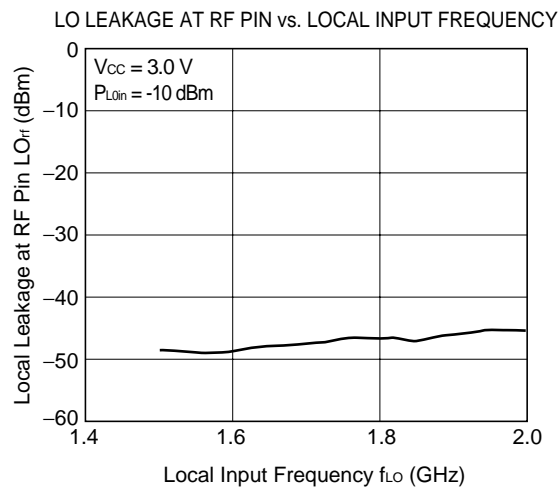
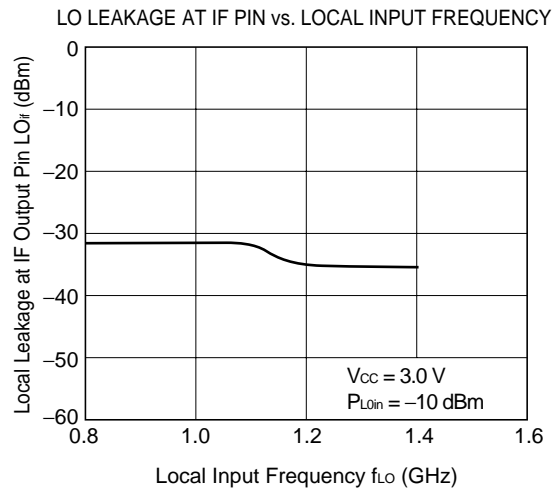

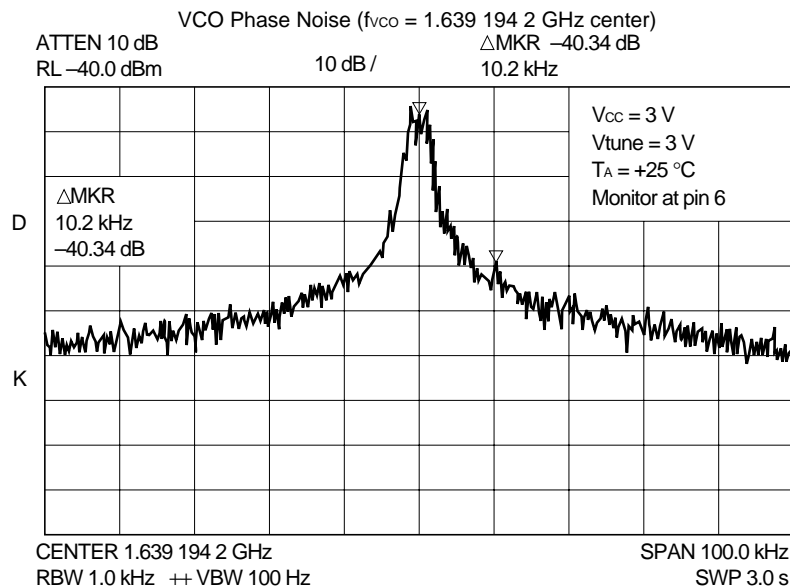
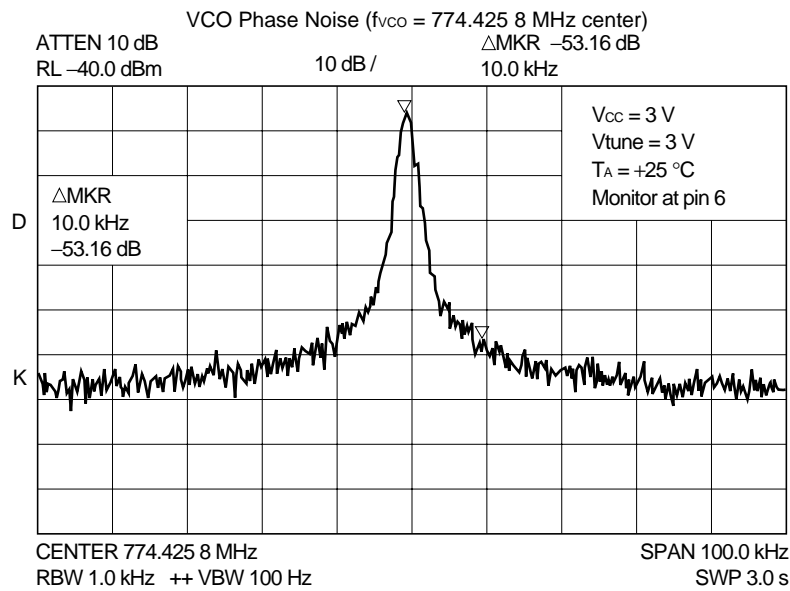
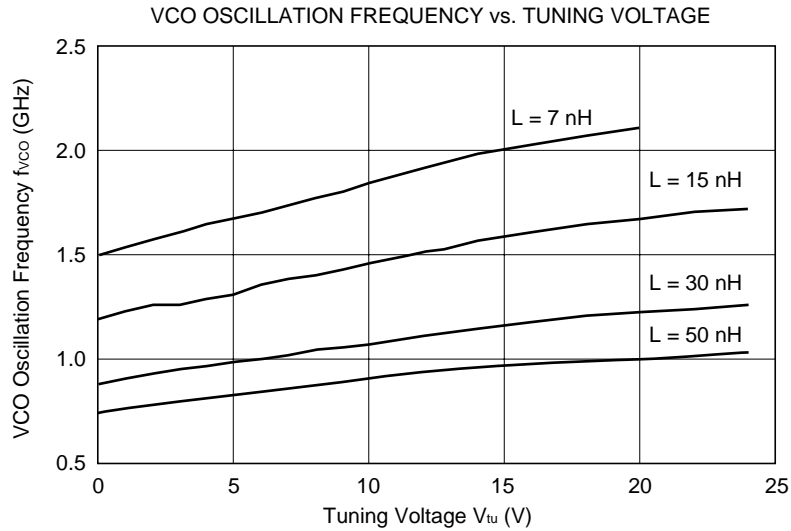

★ S-PARAMETER

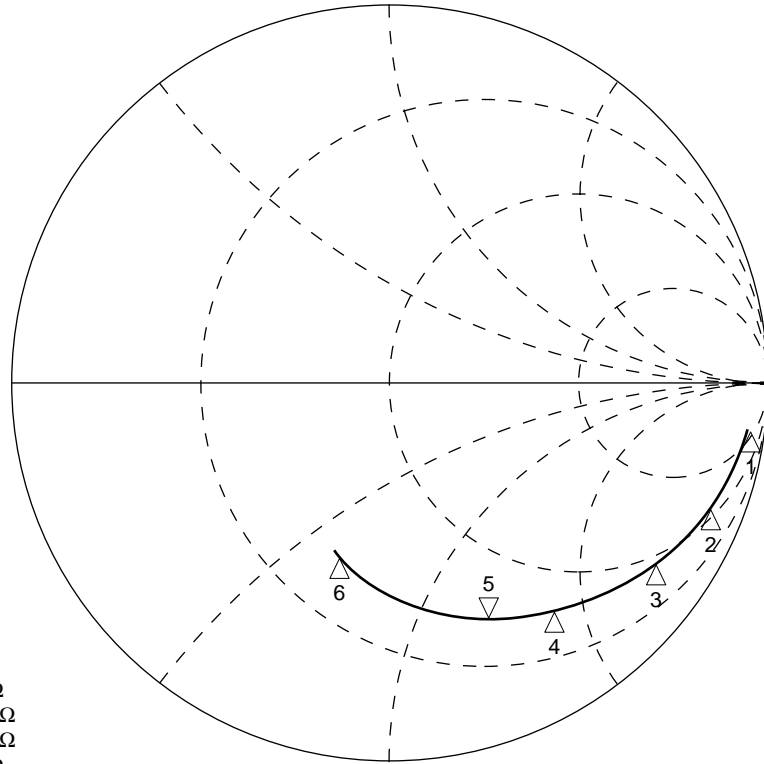

RF Port
V_{CC} = 3.0 V

Δ ₁	: 100 MHz	519.8 Ω - j 1.1 Ω
Δ ₂	: 500 MHz	59.3 Ω - j 281.0 Ω
Δ ₃	: 900 MHz	38.3 Ω - j 157.0 Ω
Δ ₄	: 1 500 MHz	31.5 Ω - j 90.1 Ω
Δ ₅	: 1 900 MHz	28.5 Ω - j 67.9 Ω
Δ ₆	: 3 000 MHz	25.7 Ω - j 31.7 Ω

START 0.10000000 GHz
STOP 3.10000000 GHz

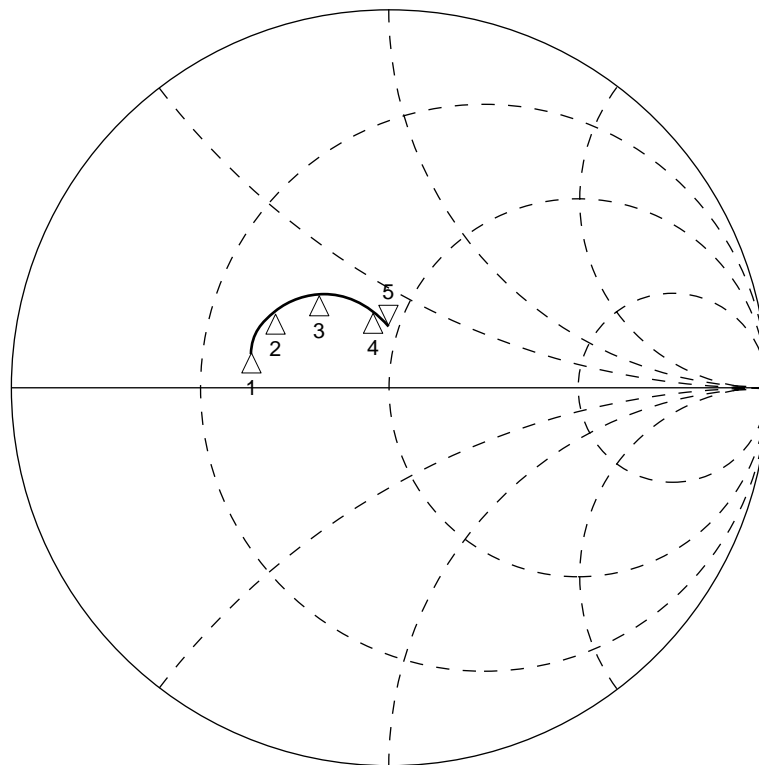

IF Port
V_{CC} = 3.0 V

Δ ₁	: 50 MHz	22.5 Ω + j 6.1 Ω
Δ ₂	: 80 MHz	24.2 Ω + j 11.3 Ω
Δ ₃	: 130 MHz	30.2 Ω + j 16.6 Ω
Δ ₄	: 240 MHz	42.6 Ω + j 17.5 Ω
Δ ₅	: 300 MHz	46.6 Ω + j 15.6 Ω

START 0.05000000 GHz
STOP 0.30000000 GHz

PACKAGE DIMENSIONS

6 pin super minimold (unit: mm)

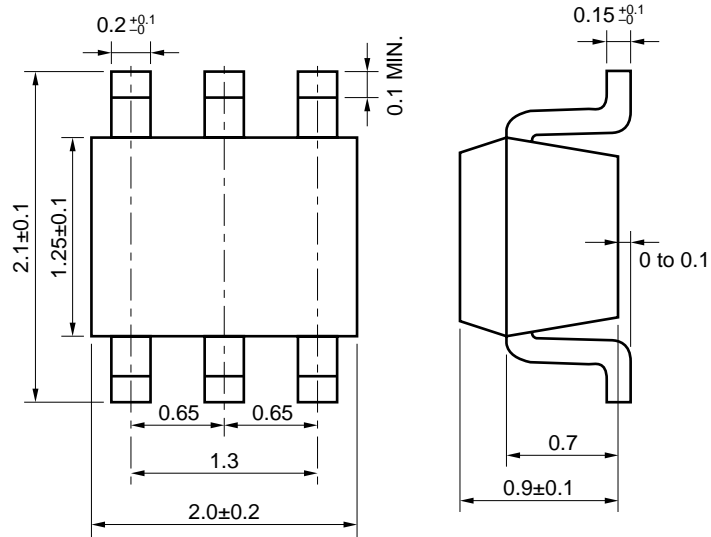

NOTE ON CORRECT USE

- (1) Observe precautions for handling because of electro-static sensitive devices.
- (2) Form a ground pattern as widely as to minimize ground impedance (to prevent abnormal oscillation).
- (3) Keep the track length between the ground pins as short as possible.
- (4) Connect a bypass capacitor (example 1 000 pF) to the Vcc pin.
- (5) To construct oscillator, tank circuit must be externally attached to pin 3 and 4.

RECOMMENDED SOLDERING CONDITIONS

This product should be soldered under the following recommended conditions. For soldering methods and conditions other than those recommended below, contact your NEC sales representative.

μPC2756TB

Soldering Method	Soldering Conditions	Recommended Condition Symbol
Infrared Reflow	Package peak temperature: 235 °C or below Time: 30 seconds or less (at 210 °C) Count: 3, Exposure limit ^{Note} : None	IR35-00-3
VPS	Package peak temperature: 215 °C or below Time: 40 seconds or less (at 200 °C) Count: 3, Exposure limit ^{Note} : None	VP15-00-3
Wave Soldering	Soldering bath temperature: 260 °C or below Time: 10 seconds or less Count: 1, Exposure limit ^{Note} : None	WS60-00-1
Partial Heating	Pin temperature: 300 °C Time: 3 seconds or less (per side of device) Exposure limit ^{Note} : None	—

Note After opening the dry pack, keep it in a place below 25 °C and 65 % RH for the allowable storage period.

Caution Do not use different soldering methods together (except for partial heating).

For details of recommended soldering conditions for surface mounting, refer to information document **SEMICONDUCTOR DEVICE MOUNTING TECHNOLOGY MANUAL (C10535E)**.

[MEMO]

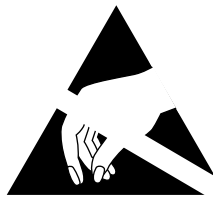

ATTENTION

OBSERVE PRECAUTIONS
FOR HANDLING
ELECTROSTATIC
SENSITIVE
DEVICES

The application circuits and their parameters are for reference only and are not intended for use in actual design-ins.

NESAT (NEC Silicon Advanced Technology) is a trademark of NEC Corporation.

No part of this document may be copied or reproduced in any form or by any means without the prior written consent of NEC Corporation. NEC Corporation assumes no responsibility for any errors which may appear in this document.

NEC Corporation does not assume any liability for infringement of patents, copyrights or other intellectual property rights of third parties by or arising from use of a device described herein or any other liability arising from use of such device. No license, either express, implied or otherwise, is granted under any patents, copyrights or other intellectual property rights of NEC Corporation or others.

While NEC Corporation has been making continuous effort to enhance the reliability of its semiconductor devices, the possibility of defects cannot be eliminated entirely. To minimize risks of damage or injury to persons or property arising from a defect in an NEC semiconductor device, customers must incorporate sufficient safety measures in its design, such as redundancy, fire-containment, and anti-failure features.

NEC devices are classified into the following three quality grades:

"Standard", "Special", and "Specific". The Specific quality grade applies only to devices developed based on a customer designated "quality assurance program" for a specific application. The recommended applications of a device depend on its quality grade, as indicated below. Customers must check the quality grade of each device before using it in a particular application.

Standard: Computers, office equipment, communications equipment, test and measurement equipment, audio and visual equipment, home electronic appliances, machine tools, personal electronic equipment and industrial robots

Special: Transportation equipment (automobiles, trains, ships, etc.), traffic control systems, anti-disaster systems, anti-crime systems, safety equipment and medical equipment (not specifically designed for life support)

Specific: Aircrafts, aerospace equipment, submersible repeaters, nuclear reactor control systems, life support systems or medical equipment for life support, etc.

The quality grade of NEC devices is "Standard" unless otherwise specified in NEC's Data Sheets or Data Books. If customers intend to use NEC devices for applications other than those specified for Standard quality grade, they should contact an NEC sales representative in advance.

Anti-radioactive design is not implemented in this product.