

# BCD-to-decimal decoder

## BU4028B

The BU4028B is a decoder which converts BCD signals to decimal signals.

Of the ten outputs  $Q_0$  to  $Q_9$ , those corresponding to the A to D input codes are set to "H", and the others are all set to "L".

If inputs A to C are used and input D is used as disabled input, the BU4028B can also be used as a 1-of-8 decoder.

### ●Features

- 1) Low power dissipation.
- 2) Wide range of operating power supply voltages.
- 3) High input impedance.
- 4) High fan-out.
- 5) Direct drive of 2 L-TTL inputs and 1LS-TTL input.

### ●Block diagram

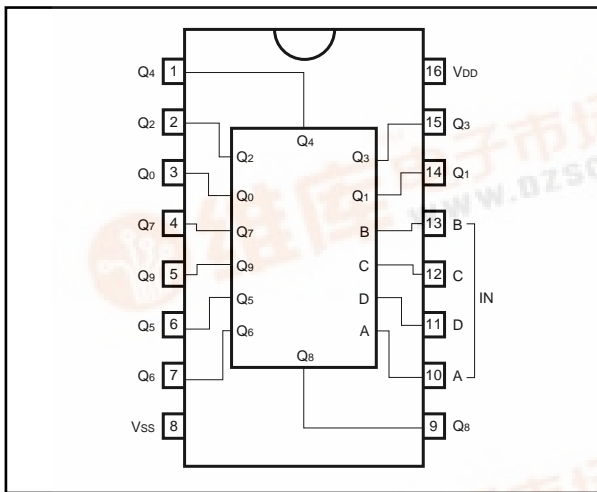

### ●Logic circuit diagram

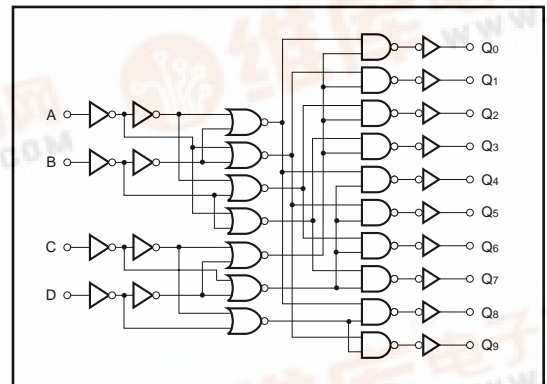

● Truth table

INPUT				OUTPUT									
D	C	B	A	Q <sub>9</sub>	Q <sub>8</sub>	Q <sub>7</sub>	Q <sub>6</sub>	Q <sub>5</sub>	Q <sub>4</sub>	Q <sub>3</sub>	Q <sub>2</sub>	Q <sub>1</sub>	Q <sub>0</sub>
L	L	L	L	L	L	L	L	L	L	L	L	L	H
L	L	L	H	L	L	L	L	L	L	L	L	H	L
L	L	H	L	L	L	L	L	L	L	L	H	L	L
L	L	H	H	L	L	L	L	L	L	H	L	L	L
L	H	L	L	L	L	L	L	L	H	L	L	L	L
L	H	L	H	L	L	L	H	L	L	L	L	L	L
L	H	H	L	L	L	L	H	L	L	L	L	L	L
L	H	H	H	L	L	L	L	L	L	L	L	L	L
H	L	L	L	L	H	L	L	L	L	L	L	L	L
H	L	L	H	H	L	L	L	L	L	L	L	L	L
H	L	H	L	L	L	L	L	L	L	L	L	L	L
H	L	H	H	L	L	L	L	L	L	L	L	L	L
H	H	L	L	L	L	L	L	L	L	L	L	L	L
H	H	L	H	L	L	L	L	L	L	L	L	L	L
H	H	H	L	L	L	L	L	L	L	L	L	L	L
H	H	H	H	L	L	L	L	L	L	L	L	L	L

● Absolute maximum ratings (Ta = 25°C, V<sub>SS</sub> = 0V)

Parameter	Symbol	Limits	Unit
Power supply voltage	V <sub>DD</sub>	- 0.3 ~ + 18	V
Power dissipation	P <sub>d</sub>	1000 (DIP)	mW
Operating temperature	T <sub>opr</sub>	- 40 ~ + 85	°C
Storage temperature	T <sub>stg</sub>	- 55 ~ + 150	°C
Input voltage	V <sub>IN</sub>	- 0.3 ~ V <sub>DD</sub> + 0.3	V

## ●Electrical characteristics

DC characteristics (unless otherwise noted,  $T_a = 25^\circ\text{C}$ ,  $V_{SS} = 0\text{V}$ )

Parameter	Symbol	Min.	Typ.	Max.	Unit	V <sub>DD</sub> (V)	Conditions	Measurement circuit
Input high level voltage	V <sub>IH</sub>	3.5	—	—	V	5	—	Fig.1
		7.0	—	—		10		
		11.0	—	—		15		
Input low level voltage	V <sub>IL</sub>	—	—	1.5	V	5	—	Fig.1
		—	—	3.0		10		
		—	—	4.0		15		
Input high level current	I <sub>IH</sub>	—	—	0.3	μA	15	V <sub>IH</sub> = 15V	Fig.1
Input low level current	I <sub>IL</sub>	—	—	-0.3	μA	15	V <sub>IL</sub> = 0V	Fig.1
Output high level voltage	V <sub>OH</sub>	4.95	—	—	V	5	I <sub>o</sub> = 0mA	Fig.1
		9.95	—	—		10		
		14.95	—	—		15		
Output low level voltage	V <sub>OL</sub>	—	—	0.05	V	5	I <sub>o</sub> = 0mA	Fig.1
		—	—	0.05		10		
		—	—	0.05		15		
Output high level current	I <sub>OH</sub>	-0.16	—	—	mA	5	V <sub>OH</sub> = 4.6V	Fig.1
		-0.4	—	—		10	V <sub>OH</sub> = 9.5V	
		-1.2	—	—		15	V <sub>OH</sub> = 13.5V	
Output low level current	I <sub>OL</sub>	0.44	—	—	mA	5	V <sub>OL</sub> = 0.4V	Fig.1
		1.1	—	—		10	V <sub>OL</sub> = 0.5V	
		3.0	—	—		15	V <sub>OL</sub> = 1.5V	
Static current dissipation	I <sub>DD</sub>	—	—	1	μA	5	V <sub>I</sub> = V <sub>DD</sub> or GND	—
		—	—	2		10		
		—	—	4		15		

Switching characteristics (Ta = 25°C, CL = 50pF, VSS = 0V)

Parameter	Symbol	Min.	Typ.	Max.	Unit	VDD (V)	Conditions	Measurement circuit
Output rise time	t <sub>RLH</sub>	—	180	—	ns	5	—	Fig.2, 3
		—	90	—		10		
		—	65	—		15		
Output fall time	t <sub>THL</sub>	—	100	—	ns	5	—	Fig.2, 3
		—	50	—		10		
		—	40	—		15		
“L” to “H” propagation delay time	t <sub>PLH</sub>	—	300	—	ns	5	—	Fig.2, 3
		—	130	—		10		
		—	90	—		15		
“H” to “L” propagation delay time	t <sub>PHL</sub>	—	300	—	ns	5	—	Fig.2, 3
		—	130	—		10		
		—	90	—		15		
Input capacitance	C <sub>IN</sub>	—	5	—	pF	—	—	—

● Measurement circuits

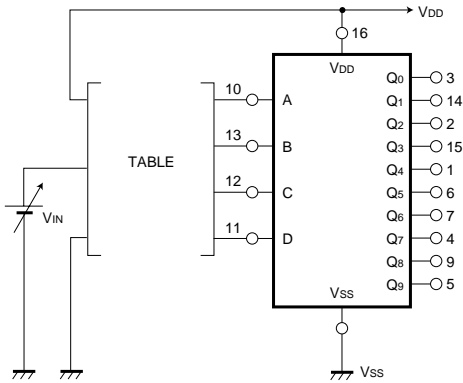
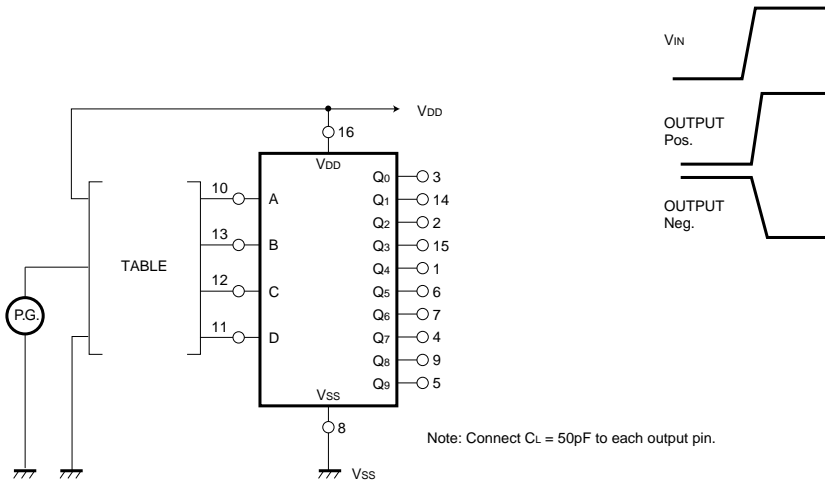

Fig. 1 DC characteristics measurement circuit

TEST NO.	INPUT				OUTPUT	
	A	B	C	D	Pos.	Neg.
1	V <sub>IN</sub>	V <sub>SS</sub>	V <sub>SS</sub>	V <sub>SS</sub>	Q <sub>1</sub>	Q <sub>0</sub>
2	V <sub>SS</sub>	V <sub>IN</sub>	V <sub>DD</sub>	V <sub>SS</sub>	Q <sub>6</sub>	Q <sub>4</sub>
3	V <sub>DD</sub>	V <sub>DD</sub>	V <sub>IN</sub>	V <sub>SS</sub>	Q <sub>7</sub>	Q <sub>3</sub>
4	V <sub>DD</sub>	V <sub>SS</sub>	V <sub>SS</sub>	V <sub>IN</sub>	Q <sub>9</sub>	Q <sub>1</sub>
5	V <sub>SS</sub>	V <sub>IN</sub>	V <sub>SS</sub>	V <sub>SS</sub>	Q <sub>2</sub>	Q <sub>0</sub>
6	V <sub>DD</sub>	V <sub>SS</sub>	V <sub>IN</sub>	V <sub>SS</sub>	Q <sub>5</sub>	Q <sub>1</sub>
7	V <sub>SS</sub>	V <sub>SS</sub>	V <sub>SS</sub>	V <sub>IN</sub>	Q <sub>8</sub>	Q <sub>0</sub>
8	V <sub>SS</sub>	V <sub>SS</sub>	V <sub>IN</sub>	V <sub>SS</sub>	Q <sub>4</sub>	Q <sub>0</sub>
9	V <sub>IN</sub>	V <sub>DD</sub>	V <sub>SS</sub>	V <sub>SS</sub>	Q <sub>3</sub>	Q <sub>2</sub>



Note: Connect C<sub>L</sub> = 50pF to each output pin.

Fig. 2 Switching characteristics measurement circuit

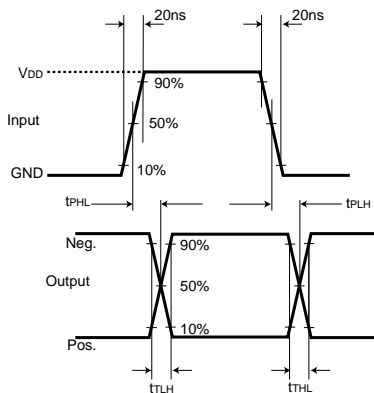

Fig. 3 Switching time test waveform

TEST NO.	INPUT				OUTPUT	
	A	B	C	D	Pos.	Neg.
1	P.G.	V <sub>SS</sub>	V <sub>SS</sub>	V <sub>SS</sub>	Q <sub>1</sub>	Q <sub>0</sub>
2	V <sub>SS</sub>	P.G.	V <sub>DD</sub>	V <sub>SS</sub>	Q <sub>6</sub>	Q <sub>4</sub>
3	V <sub>DD</sub>	V <sub>DD</sub>	P.G.	V <sub>SS</sub>	Q <sub>7</sub>	Q <sub>3</sub>
4	V <sub>DD</sub>	V <sub>SS</sub>	V <sub>SS</sub>	P.G.	Q <sub>9</sub>	Q <sub>1</sub>
5	V <sub>SS</sub>	P.G.	V <sub>SS</sub>	V <sub>SS</sub>	Q <sub>2</sub>	Q <sub>0</sub>
6	V <sub>DD</sub>	V <sub>SS</sub>	P.G.	V <sub>SS</sub>	Q <sub>5</sub>	Q <sub>1</sub>
7	V <sub>SS</sub>	V <sub>SS</sub>	V <sub>SS</sub>	P.G.	Q <sub>8</sub>	Q <sub>0</sub>
8	V <sub>SS</sub>	V <sub>SS</sub>	P.G.	V <sub>SS</sub>	Q <sub>4</sub>	Q <sub>0</sub>
9	P.G.	V <sub>DD</sub>	V <sub>SS</sub>	V <sub>SS</sub>	Q <sub>3</sub>	Q <sub>2</sub>

●Electrical characteristics curve

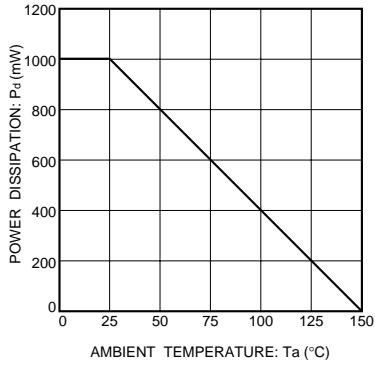

Fig.4 Power dissipation vs. Ta

●External dimensions (Units: mm)

