



TC1043

Linear Building Block – Low Power Voltage Reference with Dual Op Amp, Dual Comparator, and Shutdown Mode

Features

- Combines Two Op Amps, Two Comparators and a Voltage Reference in a Single Package
- Optimized for Single-Supply Operation
- Small Package: 16-Pin QSOP
- Ultra Low Input Bias Current: Less than 100pA
- Low Quiescent Current: Operating 16µA (Typ.) Shutdown 6µA (Typ.)
- Rail-to-Rail Inputs and Outputs
- Operates Down to $V_{DD} = 1.8V$
- Reference and One Comparator Remain Active in Shutdown to Provide Supervisory Functions

Applications

- Power Management Circuits
- Battery Operated Equipment
- Consumer Products
- Replacements for Discrete Components

Device Selection Table

Part Number	Package	Temperature Range
TC1043CEQR	16-Pin QSOP	-40°C to +85°C

Package Type

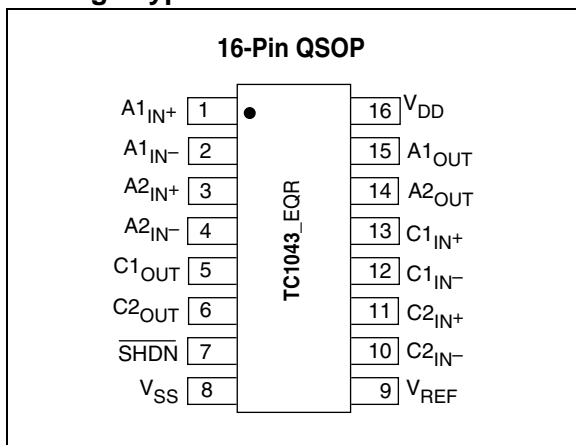

General Description

The TC1043 is a mixed-function device combining two general purpose op amps, two general purpose comparators, and a voltage reference in a single 16-Pin package.

This increased integration allows the user to replace two or three packages, saving space, lowering supply current, and increasing system performance. A shutdown input, \overline{SHDN} , disables the op amps and one of the comparators, placing their outputs in a high-impedance state. The reference and one comparator stay active in shutdown mode. Standby power consumption is typically 6µA. Both the op amps and comparators have rail-to-rail inputs and outputs which allows operation from low supply voltages with large input and output signal swings.

Packaged in a 16-Pin QSOP, the TC1043 is ideal for applications requiring high integration, small size and low power.

TC1043

1.0 ELECTRICAL CHARACTERISTICS

ABSOLUTE MAXIMUM RATINGS*

Supply Voltage	6.0V
Voltage on Any Pin	($V_{SS} - 0.3V$) to ($V_{DD} + 0.3V$)
Junction Temperature.....	+150°C
Operating Temperature Range.....	-40°C to +85°C
Storage Temperature Range	-55°C to +150°C

*Stresses above those listed under "Absolute Maximum Ratings" may cause permanent damage to the device. These are stress ratings only and functional operation of the device at these or any other conditions above those indicated in the operation sections of the specifications is not implied. Exposure to Absolute Maximum Rating conditions for extended periods may affect device reliability.

TC1043 ELECTRICAL SPECIFICATIONS

Electrical Characteristics: Typical values apply at 25°C and $V_{DD} = 3V$. Minimum and maximum values apply for $T_A = -40^\circ$ to +85°C, and $V_{DD} = 1.8V$ to 5.5V, unless otherwise specified.						
Symbol	Parameter	Min.	Typ	Max	Units	Test Conditions
V_{DD}	Supply Voltage	1.8	—	5.5	V	
I_Q	Supply Current Operating	—	16	30	μA	All outputs unloaded, $\overline{SHDN} = V_{DD}$
I_{SHDN}	Supply Current, Shutdown	—	6	10	μA	CMPTR2 and V_{REF} Outputs unloaded, $\overline{SHDN} = V_{SS}$
Shutdown Input						
V_{IH}	Input High Threshold	80% V_{DD}	—	—	V	
V_{IL}	Input Low Threshold	—	—	20% V_{DD}	V	
I_{SI}	Shutdown Input Current	—	—	± 100	nA	
Op Amps						
T_{SEL}	Select Time	—	15	—	μsec	(V_{OUT} from $\overline{SHDN} = V_{IH}$) $R_L = 10k\Omega$ to V_{SS}
T_{DESEL}	Deselect Time	—	100	—	nsec	(V_{OUT} from $\overline{SHDN} = V_{IL}$) $R_L = 10k\Omega$ to V_{SS}
$R_{OUT(SD)}$	Output Resistance in Shutdown	20	—	—	$M\Omega$	$\overline{SHDN} = V_{SS}$
$C_{OUT(SD)}$	Output Capacitance in Shutdown	—	—	6	pF	$\overline{SHDN} = V_{SS}$
A_{VOL}	Large Signal Voltage Gain	—	100	—	V/mV	$R_L = 10k\Omega$, $V_{DD} = 5V$
V_{ICMR}	Common Mode Input Voltage Range	$V_{SS} - 0.2$	—	$V_{DD} + 0.2$	V	
V_{OS}	Input Offset Voltage	—	± 100 ± 0.3	± 500 ± 1.5	μV mV	$V_{DD} = 3V$, $V_{CM} = 1.5V$, $T_A = 25^\circ C$, $T_A = -40^\circ C$ to $85^\circ C$
I_B	Input Bias Current	-100	50	100	pA	$T_A = 25^\circ C$, $V_{CM} = V_{DD}$ to V_{SS}
$V_{OS(DRIFT)}$	Input Offset Voltage Drift	—	± 4	—	$\mu V/^\circ C$	$V_{DD} = 3V$, $V_{CM} = 1.5V$
GBWP	Gain-Bandwidth Product	—	90	—	kHz	$V_{DD} = 1.8V$ to 5.5V $V_O = V_{DD}$ to V_{SS}
SR	Slew Rate	—	35	—	mV/ μsec	$C_L = 100pF$ $R_L = 1M\Omega$ to GND Gain = 1 $V_{IN} = V_{SS}$ to V_{DD}
V_{OUT}	Output Signal Swing	$V_{SS} + 0.05$	—	$V_{SS} - 0.05$	V	$R_L = 10k\Omega$
CMRR	Common Mode Rejection Ratio	70	—	—	dB	$T_A = 25^\circ C$, $V_{DD} = 5V$ $V_{CM} = V_{DD}$ to V_{SS}
PSRR	Power Supply Rejection Ratio	80	—	—	dB	$T_A = 25^\circ C$, $V_{CM} = V_{SS}$ $V_{DD} = V_{DD}$ to V_{SS}
I_{SRC}	Output Source Current	3	—	—	mA	$IN+ = V_{DD}$, $IN- = V_{SS}$ Output Shorted to V_{SS} $V_{DD} = 1.8V$, Gain = 1
I_{SINK}	Output Sink Current	4	—	—	mA	$IN+ = V_{SS}$, $IN- = V_{DD}$ Output Shorted to V_{DD} $V_{DD} = 1.8V$, Gain = 1
E_n	Input Noise Voltage	—	10	—	μV_{PP}	0.1Hz to 10Hz
e_n	Input Noise Voltage Density	—	125	—	nV/ \sqrt{Hz}	1kHz

TC1043 ELECTRICAL SPECIFICATIONS (CONTINUED)

Electrical Characteristics: Typical values apply at 25°C and $V_{DD} = 3V$. Minimum and maximum values apply for $T_A = -40^\circ$ to $+85^\circ$ C, and $V_{DD} = 1.8V$ to $5.5V$, unless otherwise specified.

Symbol	Parameter	Min.	Typ	Max	Units	Test Conditions
Comparators						
$R_{OUT(SD)}$	Output Resistance in Shutdown	20	—	—	M Ω	$\overline{SHDN} = V_{SS}$
$C_{OUT(SD)}$	Output Capacitance in Shutdown	—	—	5	pF	$\overline{SHDN} = V_{SS}$
T_{SEL}	Select Time (For Valid Output)	—	20	—	μ sec	V_{OUT} from $\overline{SHDN} = V_{IH}$ $R_L = 10k\Omega$ to V_{SS}
T_{DESEL}	Deselect Time	—	500	—	nsec	V_{OUT} from $\overline{SHDN} = V_{IL}$ $R_L = 10k\Omega$ to V_{SS}
V_{ICMR}	Common Mode Input Voltage Range	$V_{SS} - 0.2$	—	$V_{DD} + 0.2$	V	
V_{OS}	Input Offset Voltage	-5 -5	—	+5 +5	mV	$V_{DD} = 3V$, $V_{CM} = 1.5V$ $T_A = 25^\circ C$ $T_A = -40^\circ C$ to $85^\circ C$
I_B	Input Bias Current	—	—	± 100	pA	$T_A = 25^\circ C$, $IN+$, $IN-$ = V_{DD} to V_{SS}
V_{OH}	Output High Voltage	$V_{DD} - 0.3$	—	—	V	$R_L = 10k\Omega$ to V_{SS}
V_{OL}	Output Low Voltage	—	—	0.3	V	$R_L = 10k\Omega$ to V_{DD}
CMRR	Common Mode Rejection Ratio	66	—	—	dB	$T_A = 25^\circ C$, $V_{DD} = 5V$ $V_{CM} = V_{DD}$ to V_{SS}
PSRR	Power Supply Rejection Ratio	60	—	—	dB	$T_A = 25^\circ C$, $V_{CM} = 1.2V$ $V_{DD} = 1.8V$ to $5V$
I_{SRC}	Output Source Current	1	—	—	mA	$IN+ = V_{DD}$, $IN- = V_{SS}$ Output Shorted to V_{SS} $V_{DD} = 1.8V$
I_{SINK}	Output Sink Current	2	—	—	mA	$IN+ = V_{SS}$, $IN- = V_{DD}$, Output Shorted to V_{DD} $V_{DD} = 1.8V$
t_{PD1}	Response Time	—	4	—	μ sec	100mV Overdrive, $C_L = 100pF$
t_{PD2}	Response Time	—	6	—	μ sec	10mV Overdrive, $C_L = 100pF$
Voltage Reference						
V_{REF}	Reference Voltage	1.176	1.200	1.224	V	
$I_{REF(SOURCE)}$	Source Current	50	—	—	μA	
$I_{REF(SINK)}$	Sink Current	50	—	—	μA	
$C_{L(REF)}$	Load Capacitance	—	—	100	pF	
N_{VREF}	Voltage Noise	—	20	—	μV_{RMS}	100Hz to 100kHz
	Noise Density	—	1.0	—	$\mu V/\sqrt{Hz}$	1kHz

TC1043

2.0 PIN DESCRIPTION

The descriptions of the pins are listed in Table 2-1.

TABLE 2-1: PIN FUNCTION TABLE

Pin Number	Symbol	Description
1	A1 _{IN+}	Op Amp Non-Inverting Input
2	A1 _{IN-}	Op Amp Inverting Input
3	A2 _{IN+}	Op Amp Non-Inverting Input
4	A2 _{IN-}	Op Amp Inverting Input
5	C1 _{OUT}	Comparator Output
6	C2 _{OUT}	Comparator Output
7	SHDN	Shutdown Input
8	V _{SS}	Negative Power Supply
9	V _{REF}	Voltage Reference Output
10	C2 _{IN-}	Comparator Inverting Input
11	C2 _{IN+}	Comparator Non-Inverting Input
12	C1 _{IN-}	Comparator Inverting Input
13	C1 _{IN+}	Comparator Non-Inverting Input
14	A2 _{OUT}	Op Amp Output
15	A1 _{OUT}	Op Amp Output
16	V _{DD}	Positive Power Supply

3.0 DETAILED DESCRIPTION

The TC1043 is one of a series of very low power, linear building block products targeted at low voltage, single supply applications. The TC1043 minimum operating voltage is 1.8V and typical supply current is only 20 μ A (fully enabled). It combines two comparators, two op amps and a voltage reference in a single package. A shutdown mode is incorporated for easy adaptation to system power management schemes. During shutdown, all but one comparator and the voltage reference are disabled (i.e. powered down with their respective outputs at high impedance). The “still awake” comparator and voltage reference can be used as a wake-up timer, power supply monitor, LDO controller or other continuous duty circuit function.

3.1 Comparators

The TC1043 contains two comparators. The comparators input range extends beyond both supply voltages by 200mV and the outputs will swing to within several millivolts of the supplies, depending on the load current being driven.

The comparators exhibit a propagation delay and supply current which are largely independent of supply voltage. The low input bias current and offset voltage make them suitable for high impedance precision applications.

Comparator CMPTR1 is disabled during shutdown and has a high impedance output. Comparator CMPTR2 remains active.

3.2 Operational Amplifiers

The TC1043 contains two rail-to-rail op amps. The amplifiers' input range extends beyond both supplies by 200mV and the outputs will swing to within several millivolts of the supplies depending on the load current being driven.

The amplifier design is such that large signal gain, slew rate and bandwidth are largely independent of supply voltage. The low input bias current and offset voltage of the TC1043 make it suitable for precision applications. Both op amps are disabled during shutdown and have high output impedance.

3.3 Voltage Reference

A 2.0% tolerance, internally biased, 1.20V bandgap voltage reference is included in the TC1043. It has a push-pull output capable of sourcing and sinking at least 50 μ A. The voltage reference remains fully enabled during shutdown.

3.4 Shutdown Input

$\overline{\text{SHDN}}$ at V_{IL} disables both op amps and one comparator. The $\overline{\text{SHDN}}$ input cannot be allowed to float. When not used, connect it to V_{DD} . The disabled comparator's output and the two disabled op amp outputs are in a high impedance state when shutdown is active. The disabled comparator's inputs and the two disabled op amp inputs can be driven from rail-to-rail by an external voltage when the TC1043 is in shutdown. No latch-up will occur when the device is driven to its enabled state when $\overline{\text{SHDN}}$ is set to V_{IH} .

4.0 TYPICAL APPLICATIONS

The TC1043 lends itself to a wide variety of applications, particularly in battery powered systems. It typically finds application in power management, processor supervisory, and interface circuitry.

4.1 Wake-Up Timer

Many microcontrollers have a low power “sleep” mode that significantly reduces their supply current. Typically, the microcontroller is placed in this mode via a software instruction, and returns to a fully enabled state upon reception of an external signal (“wake-up”). The wake-up signal is usually supplied by a hardware timer. Most system applications demand that this timer have a long duration (typically seconds or minutes), and consume as little supply current as possible.

The circuit shown in Figure 4-1 is a wake-up timer made from comparator CMPTR2. (CMPTR2 is used because the wake-up timer must operate when SHDN is active.) Capacitor C1 charges through R1 until a voltage equal to V_R is reached, at which point the WAKE-UP is driven active. Upon wake-up, the microcontroller resets the timer by forcing a logic low on a dedicated, open drain I/O port pin. This discharges C1 through R4 (the value of R4 is chosen to limit the maximum current sunk by the I/O port pin). With a 3V supply, the circuit as shown consumes typically 6 μ A and furnishes a nominal timer duration of 25 seconds.

4.2 Precision Battery Monitor

Figure 4-2 is a precision battery low/battery dead monitoring circuit. Typically, the battery low output warns the user that a battery dead condition is imminent. Battery dead typically initiates a forced shutdown to prevent operation at low internal supply voltages (which can cause unstable system operation).

The circuit of Figure 4-2 uses a single TC1043 (one op amp is unused) and only six external resistors. AMP 1 is a simple buffer, while CMPTR1 and CMPTR2 provide precision voltage detection using V_R as a reference. Resistors R2 and R4 set the detection threshold for BATTLOW, while resistors R1 and R3 set the detection threshold for BATTFAIL. The component values shown assert BATTLOW at 2.2V (typical) and BATTFAIL at 2.0V (typical). Total current consumed by this circuit is typically 22 μ A at 3V. Resistors R5 and R6 provide hysteresis for comparators CMPTR1 and CMPTR2 respectively.

4.3 Dual LDO with Shutdown

Figure 4-3 shows a portion of a TC1043 configured as a dual low dropout regulator with shutdown. AMP1 and AMP2 are independent error amplifiers that use V_R as a reference. Resistors RA_1 , RB_1 , RA_2 and RB_2 set the feedback around the amplifiers and therefore determine the output voltage settings (please see equation in the figure). RA_1 , RB_1 , RA_2 and RB_2 can have large ohmic values (i.e. 100's of k Ω) to minimize supply current.

Using the 2N2222 output transistors as shown, these regulators exhibit low dropout operation. For example, with $V_{OUT} = 3.0V$, the typical dropout voltage is only 50mV at an output current of 50mA. The unused comparators can be used in conjunction with this circuit as power-on reset or low voltage detectors for a complete LDO solution at a very low installed cost.

4.4 External Hysteresis

Hysteresis can be set externally with two resistors using positive feedback techniques (see Figure 4-3). The design procedure for setting external comparator hysteresis is as follows:

1. Choose the feedback resistor R_C . Since the input bias current of the comparator is at most 100pA, the current through R_C can be set to 100nA (i.e. 1000 times the input bias current) and retain excellent accuracy. The current through R_C at the comparator's trip point is V_R / R_C where V_R is a stable reference voltage.

FIGURE 4-1: WAKE-UP TIMER

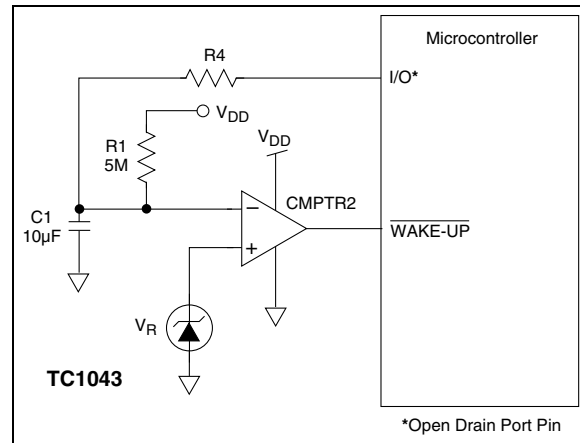

2. Determine the hysteresis voltage (V_{HY}) between the upper and lower thresholds.
3. Calculate R_A as follows:

EQUATION 4-1:

$$R_A = R_C \left(\frac{V_{HY}}{V_{DD}} \right)$$

- Choose the rising threshold voltage for V_{SRC} (V_{THR}).
- Calculate R_B as follows:

EQUATION 4-2:

$$R_B = \frac{1}{\left[\left(\frac{V_{THR}}{V_R \times R_A} \right) - \frac{1}{R_A} - \frac{1}{R_C} \right]}$$

- Verify the threshold voltages with these formulas:
 V_{SRC} rising:

EQUATION 4-3:

$$V_{THR} = (V_R)(R_A) \left[\left(\frac{1}{R_A} \right) + \left(\frac{1}{R_B} \right) + \left(\frac{1}{R_C} \right) \right]$$

V_{SRC} falling:

EQUATION 4-4:

$$V_{THF} = V_{THR} - \left[\frac{(R_A \times V_{DD})}{R_C} \right]$$

4.5 32.768kHz 'Time Of Day Clock' Crystal Controlled Oscillator

A very stable oscillator driver can be designed by using a crystal resonator as the feedback element. Figure 4-5 shows a typical application circuit using this technique to develop a clock driver for a Time-Of-Day (TOD) clock chip. The value of R_A and R_B determines the DC voltage level at which the comparator trips; in this case one-half of V_{DD} . The RC time constant of R_C and C_A should be set several times greater than the crystal oscillator's period, which will ensure a 50% duty cycle by maintaining a DC voltage at the inverting comparator input equal to the absolute average of the output signal.

4.6 Non-Retriggerable One Shot Multi-vibrator

Using two comparators, a non-retriggerable, one shot multi-vibrator can be designed using the circuit configuration of Figure 4-6. A key feature of this design is that the pulse width is independent of the magnitude of the supply voltage because the charging voltage and the intercept voltage are a fixed percentage of V_{DD} . In addition, this one shot is capable of pulse width with as much as a 99% duty cycle and exhibits input lockout to ensure that the circuit will not re-trigger before the output pulse has completely timed out. The trigger level is

the voltage required at the input to raise the voltage at node A higher than the voltage at node B, and is set by the resistive divider R_4 and R_{10} and the impedance network composed of R_1 , R_2 and R_3 . When the one shot has been triggered, the output of CMPTR2 is high, causing the reference voltage at the non-inverting input of CMPTR1 to go to V_{DD} . This prevents any additional input pulses from disturbing the circuit until the output pulse has timed out.

The value of the timing capacitor C_1 must be small enough to allow CMPTR1 to discharge C_1 to a diode voltage before the feedback signal from CMPTR2 (through R_{10}) switches CMPTR1 to its high state and allows C_1 to start an exponential charge through R_5 . Proper circuit action depends upon rapidly discharging C_1 through the voltage set by R_6 , R_9 and D_2 to a final voltage of a small diode drop. Two propagation delays after the voltage on C_1 drops below the level on the non-inverting input of CMPTR2, the output of CMPTR1 switches to the positive rail and begins to charge C_1 through R_5 . The time delay which sets the output pulse width results from C_1 charging to the reference voltage set by R_6 , R_9 and D_2 , plus four comparator propagation delays. When the voltage across C_1 charges beyond the reference, the output pulse returns to ground and the input is again ready to accept a trigger signal.

4.7 Oscillators and Pulse Width Modulators

Microchip's linear building block comparators adapt well to oscillator applications for low frequencies (less than 100kHz). Figure 4-7 shows a symmetrical square wave generator using a minimum number of components. The output is set by the RC time constant of R_4 and C_1 , and the total hysteresis of the loop is set by R_1 , R_2 and R_3 . The maximum frequency of the oscillator is limited only by the large signal propagation delay of the comparator in addition to any capacitive loading at the output which degrades the slew rate.

To analyze this circuit, assume that the output is initially high. For this to occur, the voltage at the inverting input must be less than the voltage at the non-inverting input. Therefore, capacitor C_1 is discharged. The voltage at the non-inverting input (V_H) is:

EQUATION 4-5:

$$V_H = \frac{R_2(V_{DD})}{[R_2 + (R_1 || R_3)]}$$

where, if $R_1 = R_2 = R_3$, then:

EQUATION 4-6:

$$V_H = \frac{2(V_{DD})}{3}$$

Capacitor C1 will charge up through R4. When the voltage at the comparator's inverting input is equal to V_H , the comparator output will switch. With the output at ground potential, the value at the non-inverting input terminal (V_L) is reduced by the hysteresis network to a value given by:

EQUATION 4-7:

$$V_L = \frac{V_{DD}}{3}$$

Using the same resistors as before, capacitor C1 must now discharge through R4 toward ground. The output will return to a high state when the voltage across the capacitor has discharged to a value equal to V_L . The period of oscillation will be twice the time it takes for the RC circuit to charge up to one-half its final value. The period can be calculated from:

EQUATION 4-8:

$$\frac{1}{\text{FREQ}} = 2(0.694)(R4)(C1)$$

The frequency stability of this circuit should only be a function of the external component tolerances.

Figure 4-8 shows the circuit for a pulse width modulator circuit. It is essentially the same as in Figure 4-7 with the addition of an input control voltage. When the input control voltage is equal to one-half V_{DD} , operation is basically the same as described for the free-running oscillator. If the input control voltage is moved above or below one-half V_{DD} , the duty cycle of the output square wave will be altered. This is because the addition of the control voltage at the input has now altered the trip points. The equations for these trip points are shown in Figure 4-8 (see V_H and V_L).

Pulse width sensitivity to the input voltage variations can be increased by reducing the value of R6 from 10k Ω and conversely, sensitivity will be reduced by increasing the value of R6. The values of R1 and C1 can be varied to produce the desired center frequency.

4.8 Voice Band Receive Filter

The majority of spectral energy for human voices is found to be in a 2.7kHz frequency band from 300Hz to 3kHz. To properly recover a voice signal in applications such as radios, cellular phones, and voice pagers, a low power bandpass filter that is matched to the human voice spectrum can be implemented using Microchip's CMOS op amps. Figure 4-9 shows a unity gain multi-pole Butterworth filter with ripple less than 0.15dB in the human voice band. The lower 3dB cut-off frequency is 70Hz (single order response), while the upper cut-off frequency is 3.5kHz (fourth order response).

4.9 Supervisory Audio Tone (SAT) Filter for Cellular

Supervisory Audio Tones (SAT) provide a reliable transmission path between cellular subscriber units and base stations. The SAT tone functions much like the current/voltage used in land line telephone systems to indicate that a phone is off the hook. The SAT tone may be one of three frequencies: 5970, 6000 or 6030Hz. A loss of SAT implies that channel conditions are impaired and if SAT is interrupted for more than 5 seconds a cellular call is terminated.

Figure 4-10 shows a high Q (30) second order SAT detection bandpass filter using Microchip's CMOS op amp architecture. This circuit nulls all frequencies except the three SAT tones of interest.

TC1043

FIGURE 4-4: COMPARATOR EXTERNAL HYSTERESIS CONFIGURATION

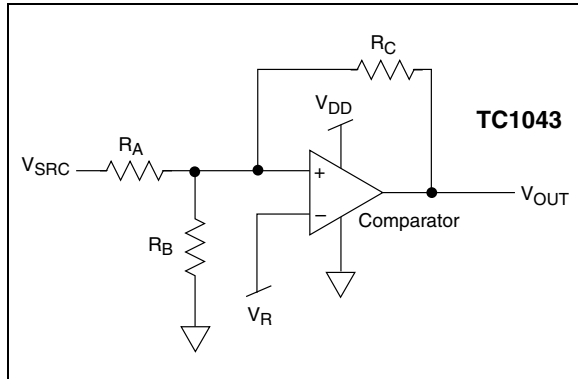

FIGURE 4-5: 32.768 KHZ "TIME-OF-DAY" CLOCK OSCILLATOR

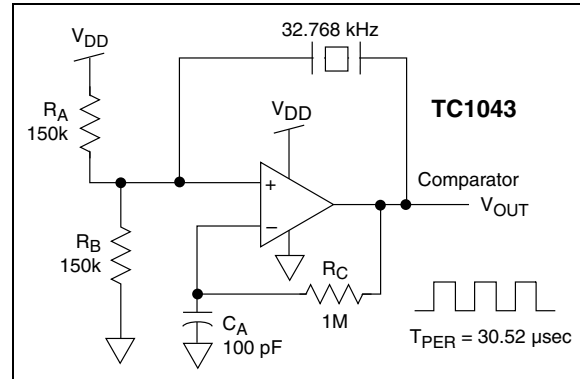

FIGURE 4-6: NON-RETRIGGERABLE MULTI-VIBRATOR

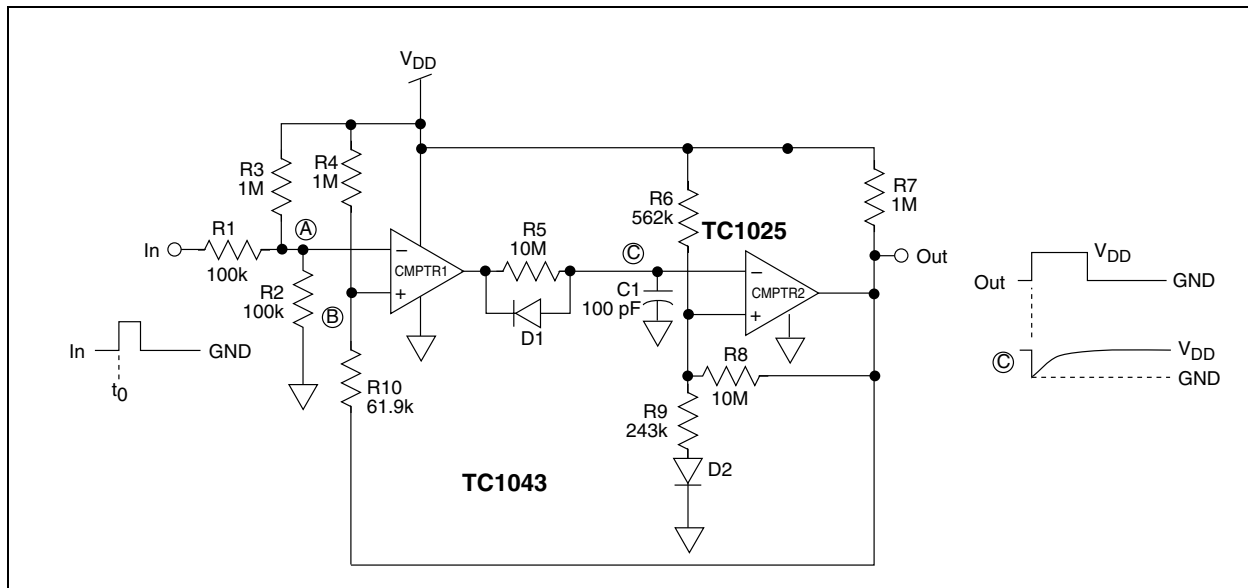

FIGURE 4-7: SQUARE WAVE GENERATOR

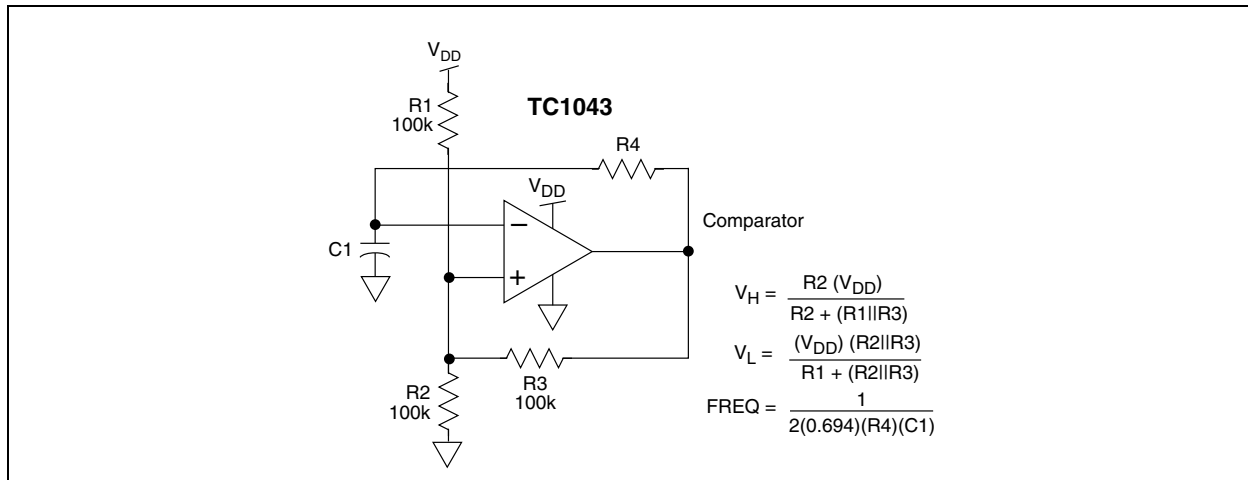

FIGURE 4-8: PULSE WIDTH MODULATOR

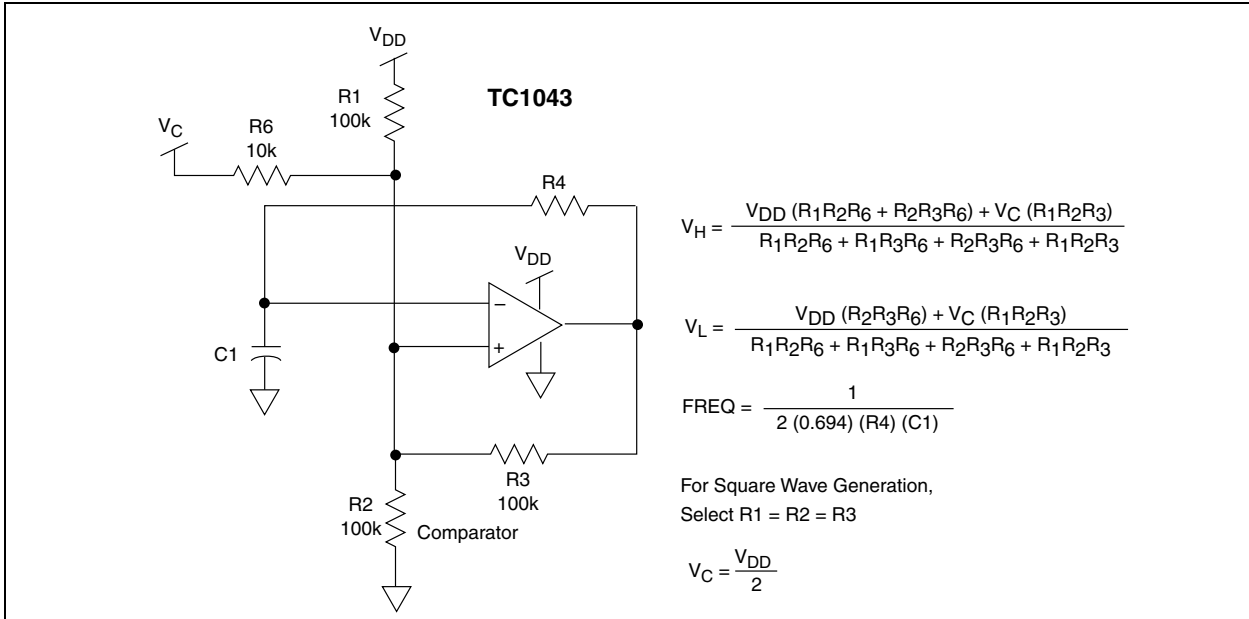
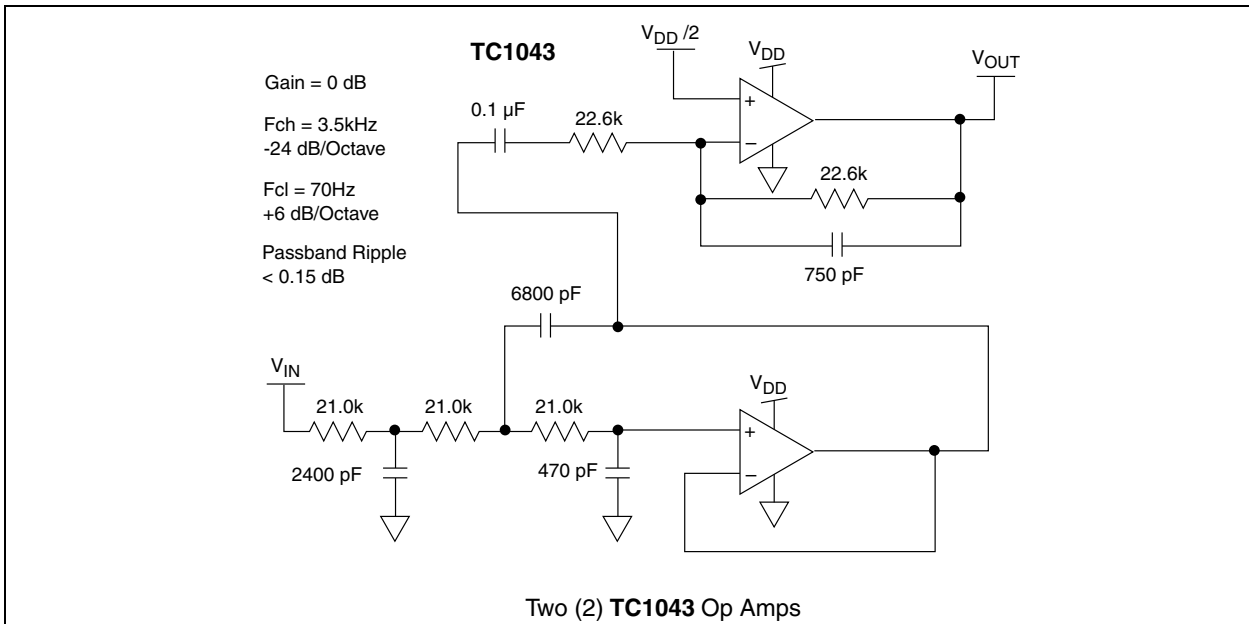
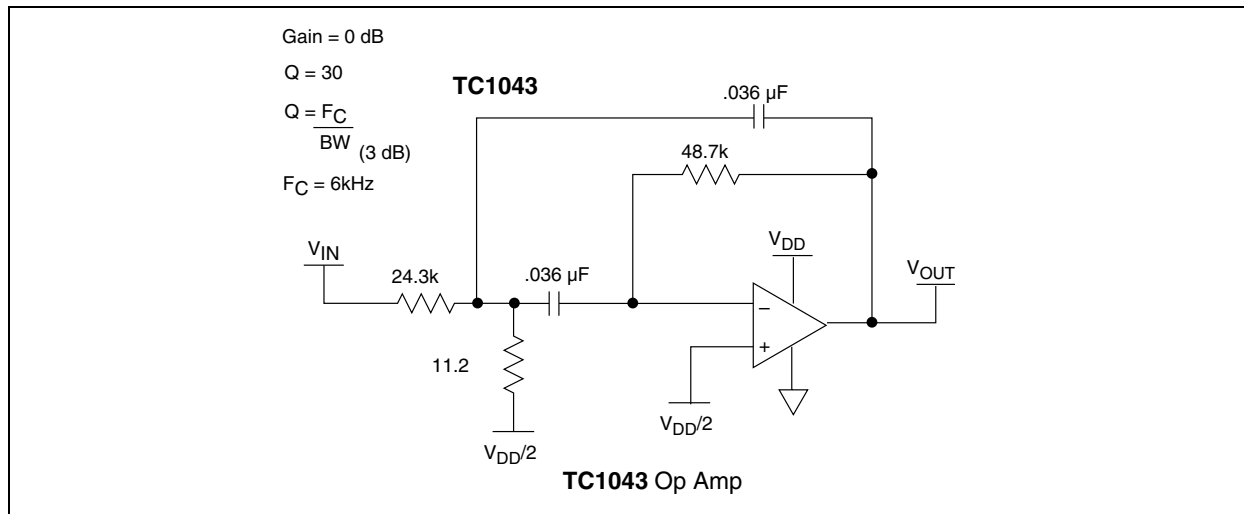

FIGURE 4-9: MULTI-POLE BUTTERWORTH VOICE BAND RECEIVE FILTER



TC1043

FIGURE 4-10: SECOND ORDER SAT BANDPASS FILTER



5.0 TYPICAL CHARACTERISTICS

Note: The graphs and tables provided following this note are a statistical summary based on a limited number of samples and are provided for informational purposes only. The performance characteristics listed herein are not tested or guaranteed. In some graphs or tables, the data presented may be outside the specified operating range (e.g., outside specified power supply range) and therefore outside the warranted range.

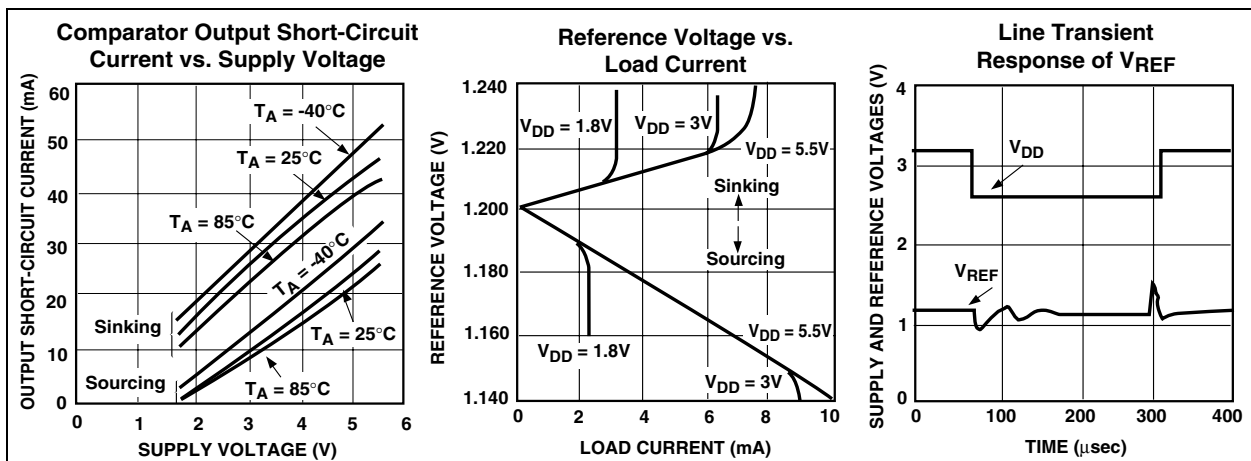
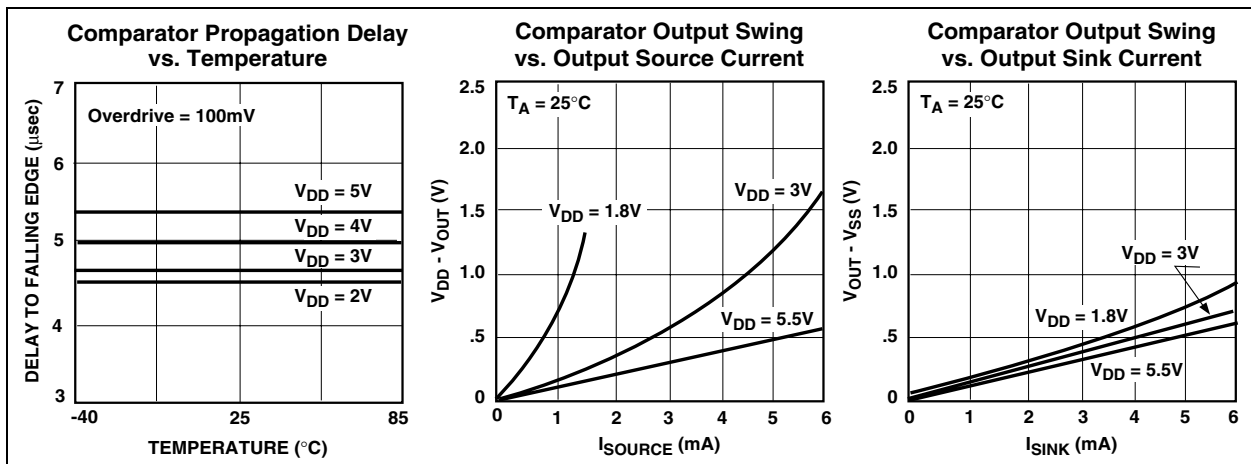
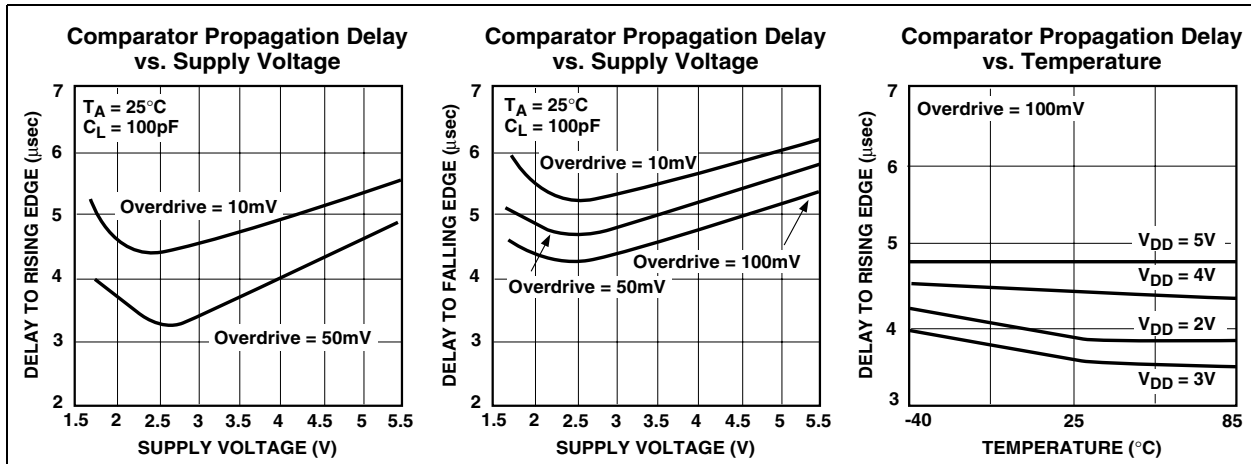

TYPICAL CHARACTERISTICS (CONTINUED)

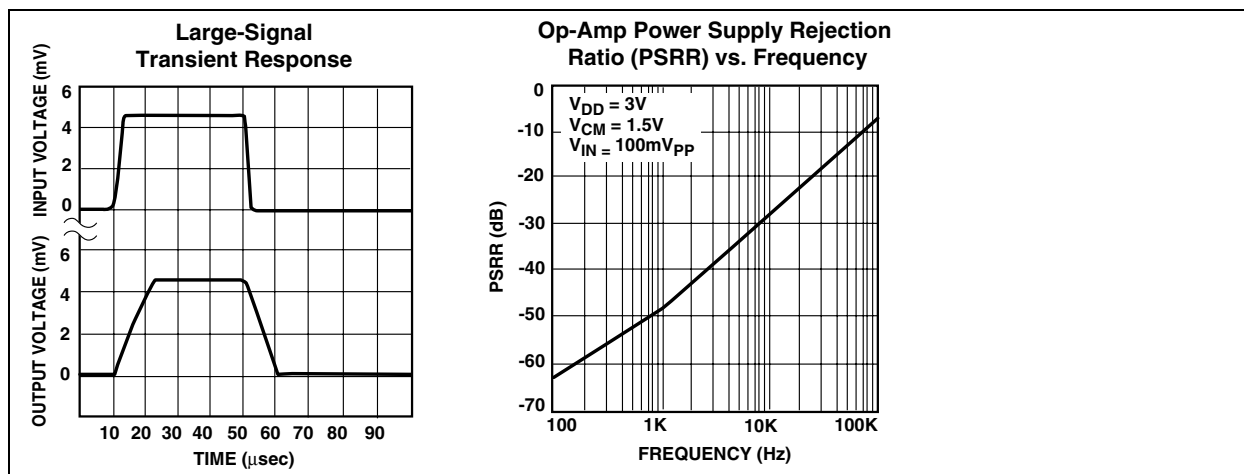
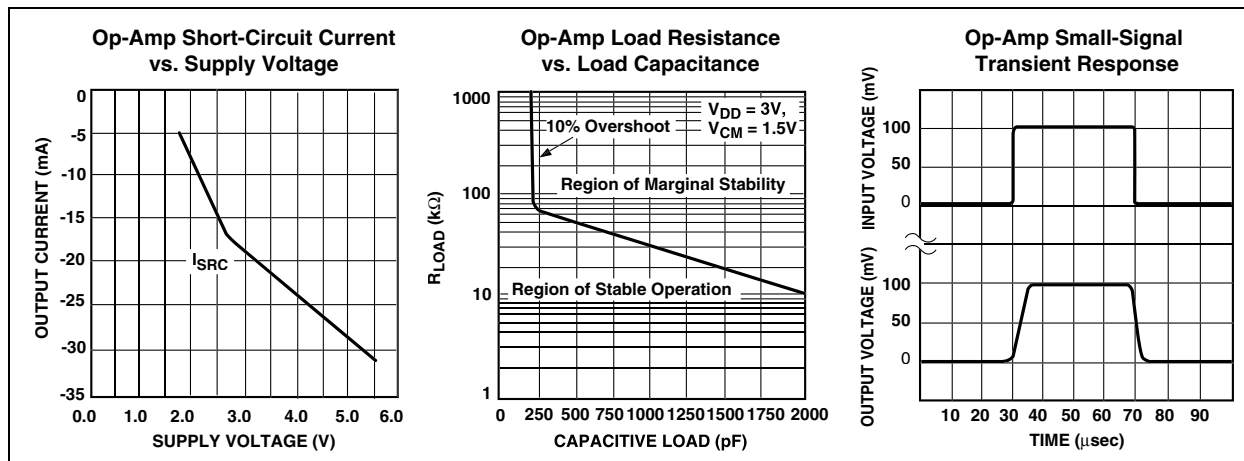
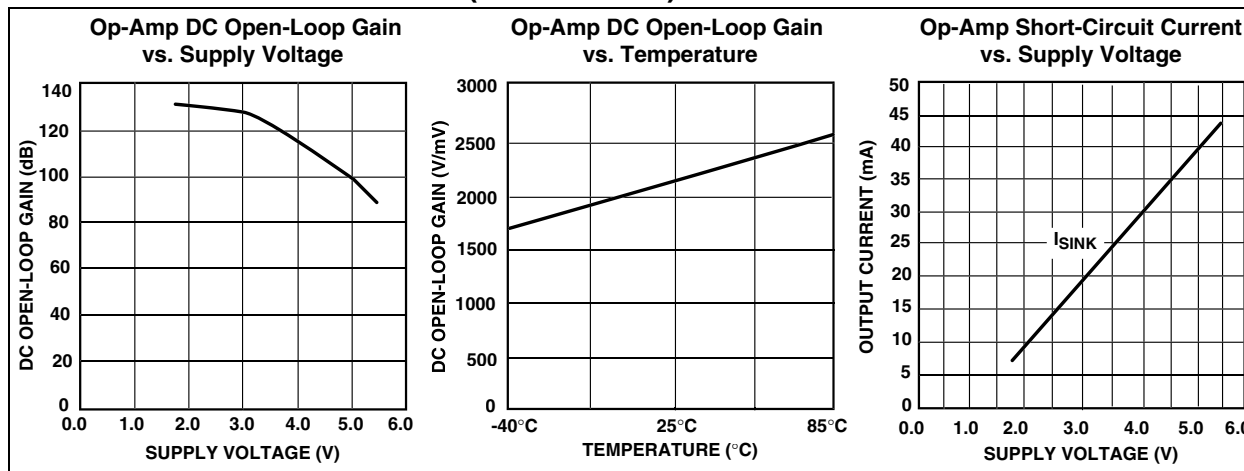

TYPICAL CHARACTERISTICS (CONTINUED)

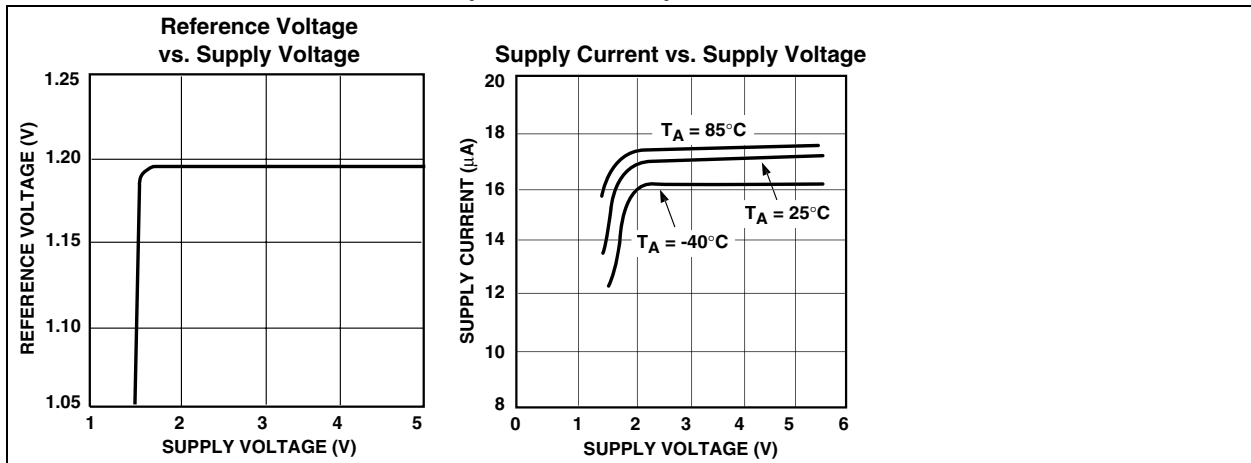

TC1043

6.0 PACKAGING INFORMATION

6.1 Package Marking Information

Package marking information not available at this time.

6.2 Taping Information

Component Taping Orientation for 16-Pin QSOP (Narrow) Devices

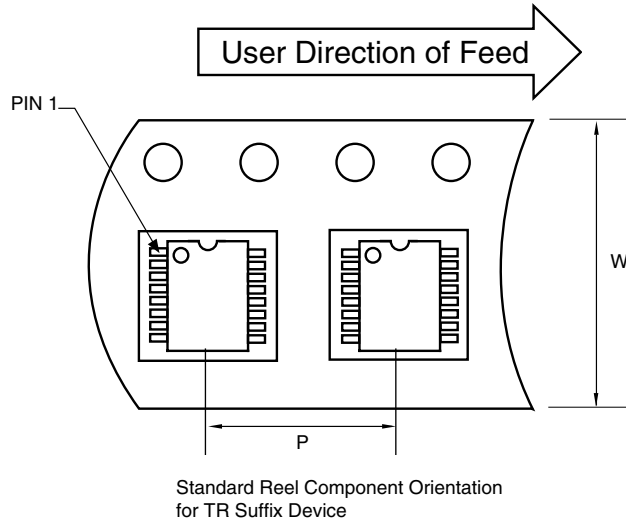

Carrier Tape, Reel Size, Number of Components Per Reel and Reel Size

Package	Carrier Width (W)	Pitch (P)	Part Per Full Reel	Reel Size
16-Pin QSOP (N)	12 mm	8 mm	2500	13 in

6.3 Package Dimensions

16-Pin QSOP (Narrow)

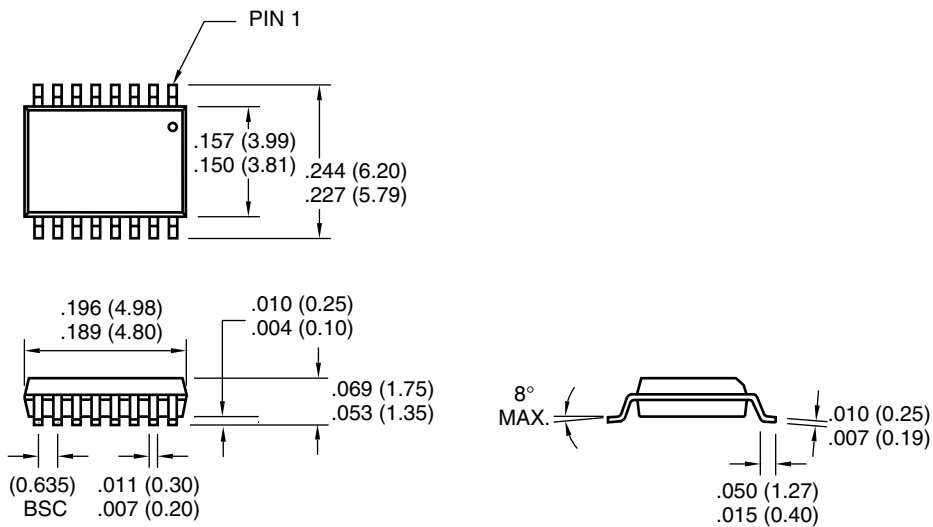

Dimensions: inches (mm)

SALES AND SUPPORT

Data Sheets

Products supported by a preliminary Data Sheet may have an errata sheet describing minor operational differences and recommended workarounds. To determine if an errata sheet exists for a particular device, please contact one of the following:

1. Your local Microchip sales office
2. The Microchip Corporate Literature Center U.S. FAX: (480) 792-7277
3. The Microchip Worldwide Site (www.microchip.com)

Please specify which device, revision of silicon and Data Sheet (include Literature #) you are using.

New Customer Notification System

Register on our web site (www.microchip.com/cn) to receive the most current information on our products.

TC1043

NOTES:

Information contained in this publication regarding device applications and the like is intended through suggestion only and may be superseded by updates. It is your responsibility to ensure that your application meets with your specifications. No representation or warranty is given and no liability is assumed by Microchip Technology Incorporated with respect to the accuracy or use of such information, or infringement of patents or other intellectual property rights arising from such use or otherwise. Use of Microchip's products as critical components in life support systems is not authorized except with express written approval by Microchip. No licenses are conveyed, implicitly or otherwise, under any intellectual property rights.

Trademarks

The Microchip name and logo, the Microchip logo, FilterLab, KEELOQ, microID, MPLAB, PIC, PICmicro, PICMASTER, PICSTART, PRO MATE, SEEVAL and The Embedded Control Solutions Company are registered trademarks of Microchip Technology Incorporated in the U.S.A. and other countries.

dsPIC, ECONOMONITOR, FanSense, FlexROM, fuzzyLAB, In-Circuit Serial Programming, ICSP, ICEPIC, microPort, Migratable Memory, MPASM, MPLIB, MPLINK, MPSIM, MXDEV, PICC, PICDEM, PICDEM.net, rfPIC, Select Mode and Total Endurance are trademarks of Microchip Technology Incorporated in the U.S.A.

Serialized Quick Turn Programming (SQTP) is a service mark of Microchip Technology Incorporated in the U.S.A.

All other trademarks mentioned herein are property of their respective companies.

© 2002, Microchip Technology Incorporated, Printed in the U.S.A., All Rights Reserved.

 Printed on recycled paper.

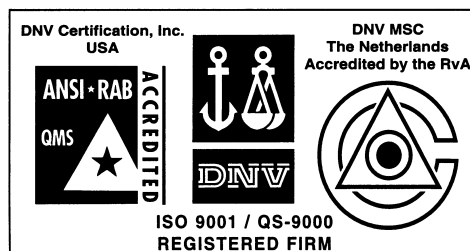

Microchip received QS-9000 quality system certification for its worldwide headquarters, design and wafer fabrication facilities in Chandler and Tempe, Arizona in July 1999 and Mountain View, California in March 2002. The Company's quality system processes and procedures are QS-9000 compliant for its PICmicro® 8-bit MCUs, KEELOQ® code hopping devices, Serial EEPROMs, microperipherals, non-volatile memory and analog products. In addition, Microchip's quality system for the design and manufacture of development systems is ISO 9001 certified.



MICROCHIP

WORLDWIDE SALES AND SERVICE

AMERICAS

Corporate Office

2355 West Chandler Blvd.
Chandler, AZ 85224-6199
Tel: 480-792-7200 Fax: 480-792-7277
Technical Support: 480-792-7627
Web Address: <http://www.microchip.com>

Rocky Mountain

2355 West Chandler Blvd.
Chandler, AZ 85224-6199
Tel: 480-792-7966 Fax: 480-792-7456

Atlanta

500 Sugar Mill Road, Suite 200B
Atlanta, GA 30350
Tel: 770-640-0034 Fax: 770-640-0307

Boston

2 Lan Drive, Suite 120
Westford, MA 01886
Tel: 978-692-3848 Fax: 978-692-3821

Chicago

333 Pierce Road, Suite 180
Itasca, IL 60143
Tel: 630-285-0071 Fax: 630-285-0075

Dallas

4570 Westgrove Drive, Suite 160
Addison, TX 75001
Tel: 972-818-7423 Fax: 972-818-2924

Detroit

Tri-Atria Office Building
32255 Northwestern Highway, Suite 190
Farmington Hills, MI 48334
Tel: 248-538-2250 Fax: 248-538-2260

Kokomo

2767 S. Albright Road
Kokomo, Indiana 46902
Tel: 765-864-8360 Fax: 765-864-8387

Los Angeles

18201 Von Karman, Suite 1090
Irvine, CA 92612
Tel: 949-263-1888 Fax: 949-263-1338

New York

150 Motor Parkway, Suite 202
Hauppauge, NY 11788
Tel: 631-273-5305 Fax: 631-273-5335

San Jose

Microchip Technology Inc.
2107 North First Street, Suite 590
San Jose, CA 95131
Tel: 408-436-7950 Fax: 408-436-7955

Toronto

6285 Northam Drive, Suite 108
Mississauga, Ontario L4V 1X5, Canada
Tel: 905-673-0699 Fax: 905-673-6509

ASIA/PACIFIC

Australia

Microchip Technology Australia Pty Ltd
Suite 22, 41 Rawson Street
Epping 2121, NSW
Australia
Tel: 61-2-9868-6733 Fax: 61-2-9868-6755

China - Beijing

Microchip Technology Consulting (Shanghai)
Co., Ltd., Beijing Liaison Office
Unit 915
Bei Hai Wan Tai Bldg.
No. 6 Chaoyangmen Beidajie
Beijing, 100027, No. China
Tel: 86-10-85282100 Fax: 86-10-85282104

China - Chengdu

Microchip Technology Consulting (Shanghai)
Co., Ltd., Chengdu Liaison Office
Rm. 2401, 24th Floor,
Ming Xing Financial Tower
No. 88 TIDU Street
Chengdu 610016, China
Tel: 86-28-6766200 Fax: 86-28-6766599

China - Fuzhou

Microchip Technology Consulting (Shanghai)
Co., Ltd., Fuzhou Liaison Office
Unit 28F, World Trade Plaza
No. 71 Wusi Road
Fuzhou 350001, China
Tel: 86-591-7503506 Fax: 86-591-7503521

China - Shanghai

Microchip Technology Consulting (Shanghai)
Co., Ltd.
Room 701, Bldg. B
Far East International Plaza
No. 317 Xian Xia Road
Shanghai, 200051
Tel: 86-21-6275-5700 Fax: 86-21-6275-5060

China - Shenzhen

Microchip Technology Consulting (Shanghai)
Co., Ltd., Shenzhen Liaison Office
Rm. 1315, 13/F, Shenzhen Kerry Centre,
Renminnan Lu
Shenzhen 518001, China
Tel: 86-755-2350361 Fax: 86-755-2366086

Hong Kong

Microchip Technology Hongkong Ltd.
Unit 901-6, Tower 2, Metroplaza
223 Hing Fong Road
Kwai Fong, N.T., Hong Kong
Tel: 852-2401-1200 Fax: 852-2401-3431

India

Microchip Technology Inc.
India Liaison Office
Divyasree Chambers
1 Floor, Wing A (A3/A4)
No. 11, O'Shaugnessey Road
Bangalore, 560 025, India
Tel: 91-80-2290061 Fax: 91-80-2290062

Japan

Microchip Technology Japan K.K.
Benex S-1 6F
3-18-20, Shinyokohama
Kohoku-Ku, Yokohama-shi
Kanagawa, 222-0033, Japan
Tel: 81-45-471-6166 Fax: 81-45-471-6122

Korea

Microchip Technology Korea
168-1, Youngbo Bldg. 3 Floor
Samsung-Dong, Kangnam-Ku
Seoul, Korea 135-882
Tel: 82-2-554-7200 Fax: 82-2-558-5934

Singapore

Microchip Technology Singapore Pte Ltd.
200 Middle Road
#07-02 Prime Centre
Singapore, 188980
Tel: 65-6334-8870 Fax: 65-6334-8850

Taiwan

Microchip Technology Taiwan
11F-3, No. 207
Tung Hua North Road
Taipei, 105, Taiwan
Tel: 886-2-2717-7175 Fax: 886-2-2545-0139

EUROPE

Denmark

Microchip Technology Nordic ApS
Regus Business Centre
Lautrup høj 1-3
Ballerup DK-2750 Denmark
Tel: 45 4420 9895 Fax: 45 4420 9910

France

Microchip Technology SARL
Parc d'Activite du Moulin de Massy
43 Rue du Saule Trapu
Batiment A - 1er Etage
91300 Massy, France
Tel: 33-1-69-53-63-20 Fax: 33-1-69-30-90-79

Germany

Microchip Technology GmbH
Gustav-Heinemann Ring 125
D-81739 Munich, Germany
Tel: 49-89-627-144 0 Fax: 49-89-627-144-44

Italy

Microchip Technology SRL
Centro Direzionale Colleoni
Palazzo Taurus 1 V. Le Colleoni 1
20041 Agrate Brianza
Milan, Italy
Tel: 39-039-65791-1 Fax: 39-039-6899883

United Kingdom

Arizona Microchip Technology Ltd.
505 Eskdale Road
Winnersh Triangle
Wokingham
Berkshire, England RG41 5TU
Tel: 44 118 921 5869 Fax: 44-118 921-5820

03/01/02