



# CLP30-200B1

Application Specific Discretets  
A.S.D™

## OVERVOLTAGE & OVERCURRENT PROTECTION FOR TELECOM LINE

### MAIN APPLICATIONS

Any telecom equipment submitted to transient overvoltages and lightning strikes such as :

- Analog and ISDN line cards
- PABX

### DESCRIPTION

The CLP30-200B1 is designed to protect telecommunication equipment. It provides both a transient overvoltage protection and an overcurrent protection.

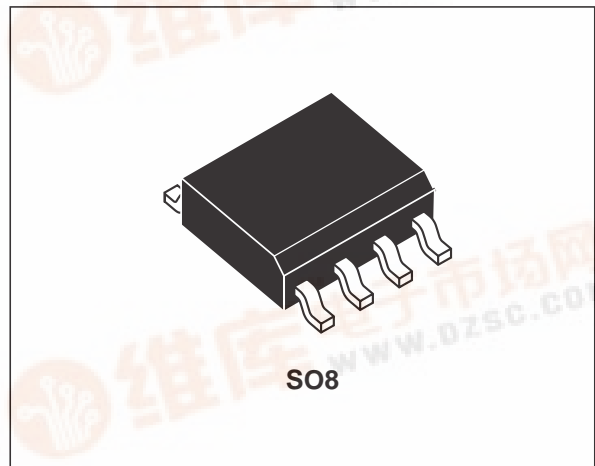
The external components (balanced resistors, ring relays contact, ...) needed by the CLP30-200B1 protection concept require very low power rating. This results in a very cost effective protection solution.

### FEATURES

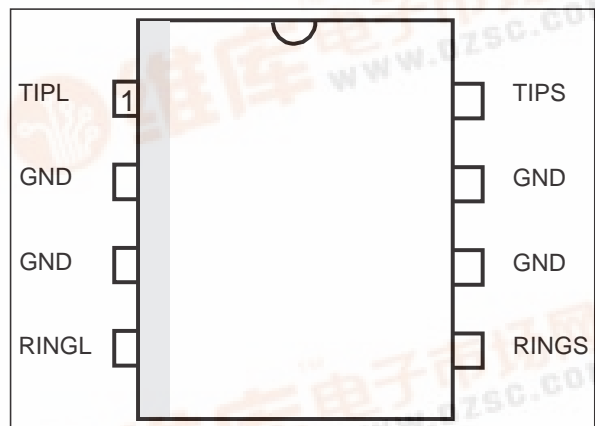
- Dual bidirectional protection device.
- High peak pulse current :  
 $I_{PP} = 40A$  (5/310  $\mu s$  SURGE)  
 $I_{PP} = 30A$  (10/1000  $\mu s$  SURGE)
- Max. voltage at switching-on : 290V
- Min. current at switching-off : 150mA

### BENEFITS

- Voltage and current controlled suppression.
- Surface Mounting with SO8 package.
- Very low power rating of external components on line card : balanced resistors, ring relay, low voltage SLIC protection.



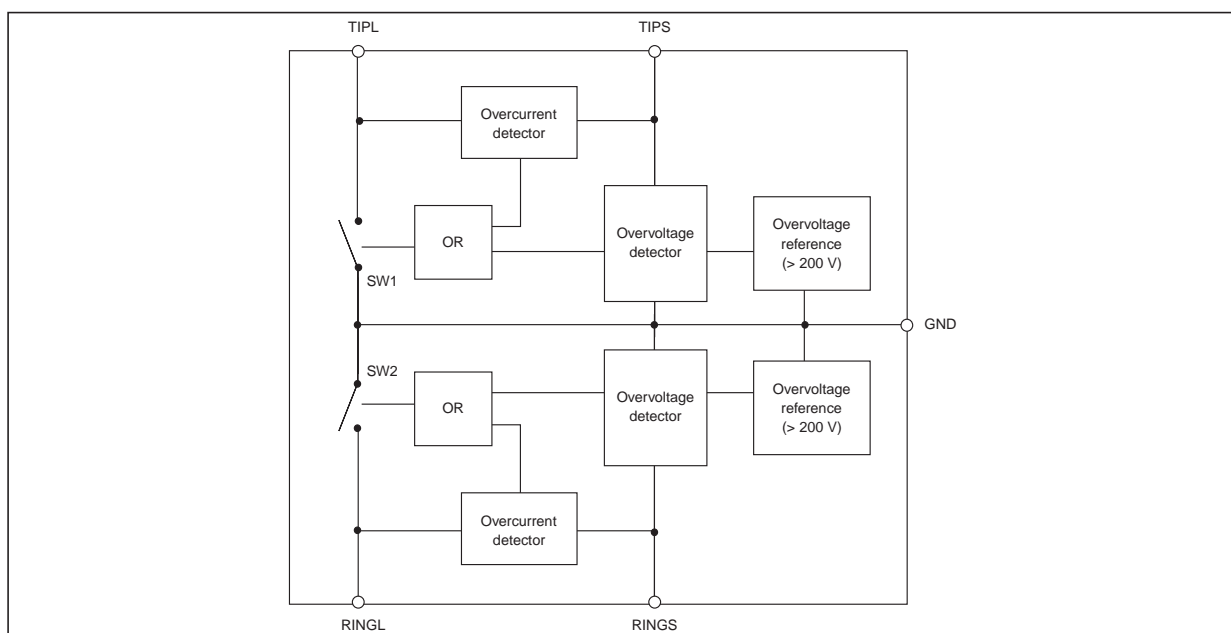
### SCHEMATIC DIAGRAM (Top view)



### CLP30-200B1

Standard	Peak surge voltage (V)	Voltage waveform	Required peak current (A)	Current waveform	Minimum serial resistor to meet standard ( $\Omega$ )
Bellcore TR-NWT-1089 First level	2500 1000	2/10 $\mu$ s 10/100 $\mu$ s	500 100	2/10 $\mu$ s 10/1000 $\mu$ s	20 25
Bellcore TR-NWT-1089 Second level	5000	2/10 $\mu$ s	500	2/10 $\mu$ s	40
ITU-T-K20 / K21	4000 1000	10/700 $\mu$ s	100 25	5/310 $\mu$ s	50 0
ITU-T-K20 (IEC61000-4-2)	6000 8000	1/60 ns	ESD contact discharge ESD air discharge		0 0
VDE0433	4000 2000	10/700 $\mu$ s	100 50	5/310 $\mu$ s	50 5
VDE0878	4000 2000	1.2/50 $\mu$ s	100 50	1/20 $\mu$ s	22 0
IEC61000-4-5	4000 2000 4000	10/700 $\mu$ s 1.2/50 $\mu$ s 1.2/50 $\mu$ s	100 50 100	5/310 $\mu$ s 8/20 $\mu$ s 8/20 $\mu$ s	50 0 22
FCC Part 68, lightning surge type A	1500 800	10/160 $\mu$ s 10/560 $\mu$ s	200 100	10/160 $\mu$ s 10/560 $\mu$ s	17.5 12
FCC Part 68, lightning surge type B	1000	9/720 $\mu$ s	25	5/320 $\mu$ s	0

### BLOCK DIAGRAM



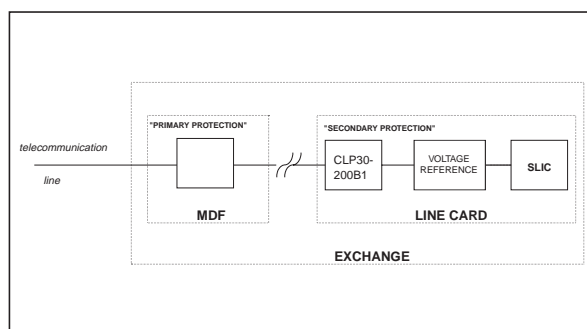
Pin	Symbol	Description
1	TIPL	TIP (Line side)
2 / 3 / 6 / 7	GND	Ground
4	RINGL	RING (Line side)
5	RINGS	RING (SLIC side)
8	TIPS	TIP (SLIC side)

## APPLICATION NOTE

### 1. INTRODUCTION

The aim of this section is to show the behavior of our new telecom line protection device.

**Fig.1** : Subscriber line protection topology



**Figure 1** is a simplified block diagram of a subscriber line protection that is mainly used so far.

This shows two different things :

- A “primary protection” located on the Main Distribution Frame (MDF) eliminates coarsely the high energy environmental disturbances (lightning transients and AC power mains disturbances) for which the ITU-T-K20 requires a 4kV 10/700  $\mu$ s test. This can be assumed either by gas-tubes or silicon protection such as the TLPxxM.
- A “secondary protection” located on the line card eliminates finely the remaining transients that have not been totally suppressed by the first stage. The ITU-T-K20 requires a 1 kV 10/700  $\mu$ s test. At this stage, the protection is managed by the CLP30-200B1.

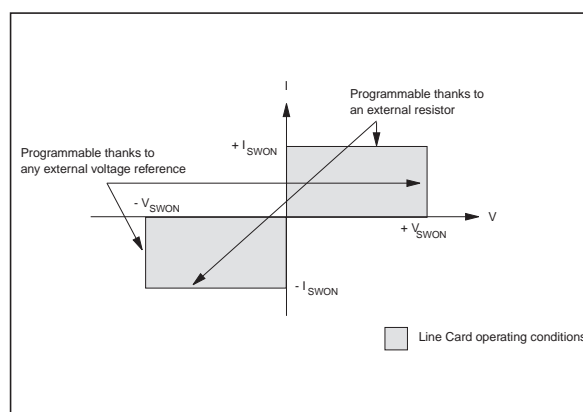
### 2. STMicroelectronics CLP30-200B1 CONCEPT

#### 2.1 Evolution of the SLIC protection

Over the years, the performances of the SLICs considerably increased and therefore the need of the protection has also evolved.

The CLP30-200B1 is especially designed for the protection of this new generation of SLIC. For this, it is based on both overvoltage and overcurrent protection modes.

**Fig.2** : Line card protection



The **figure 2** summarises the performance of the CLP30-200B1 which basically holds the SLIC inside its correct voltage and current values.

## CLP30-200B1

### APPLICATION CIRCUIT : CLP30-200B1 in line card

Fig.3 : CLP30-200B1 in line card

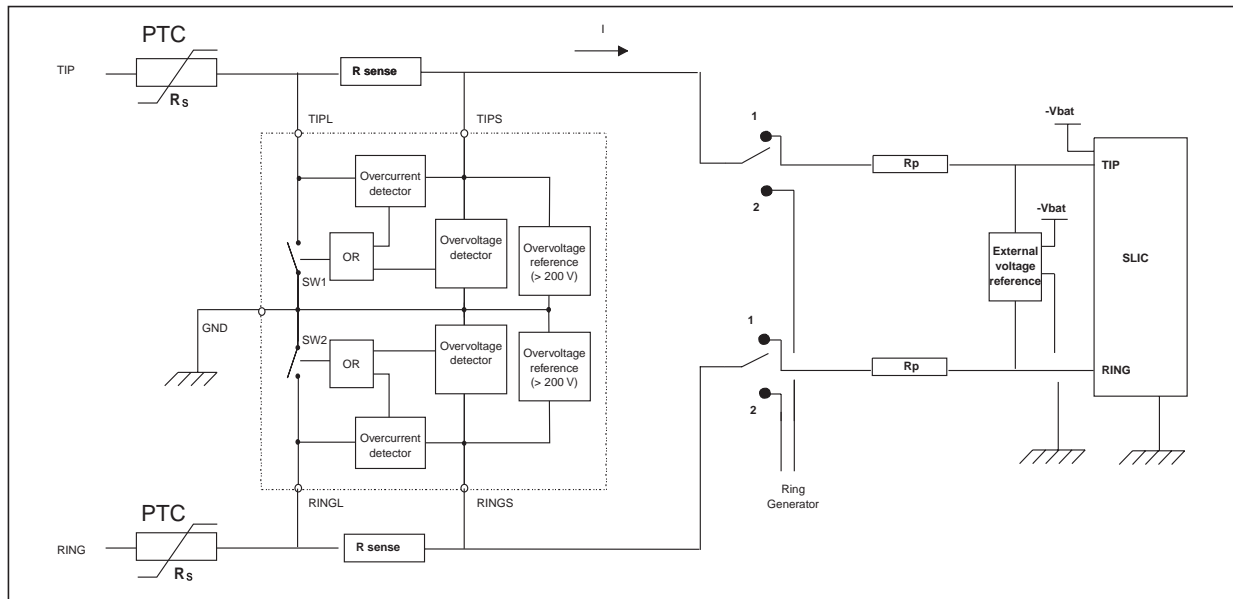
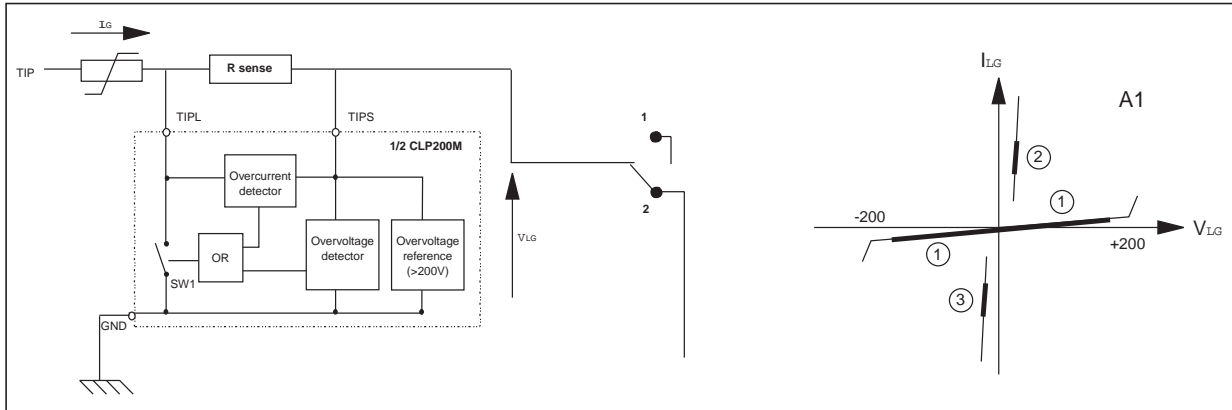


Figure above shows the topology of a protected analog subscriber line at the line card side.

- A first stage based on CLP30-200B1 manages the high power issued from the external surges. When used in ringing mode, the CLP30-200B1 operates in voltage mode and provides a symmetrical and bidirectional overvoltage protection above 200 V on both TIP and RING lines. When used in speech mode, the CLP30-200B1 operates in current mode and the activation current of the CLP30-200B1 is adjusted by  $R_{SENSE}$ .
- A second stage which is the external voltage reference device defines the firing threshold voltage during the speech mode and also assumes a residual power overvoltage suppression. This stage can be either a fixed or programmable device such as LCP1511D.

2.3 Ringing mode

Fig.4 : Switching by voltage during ringing mode.



In ringing mode (Ring relay in position 2), the only protection device involved is the CLP30-200B1.

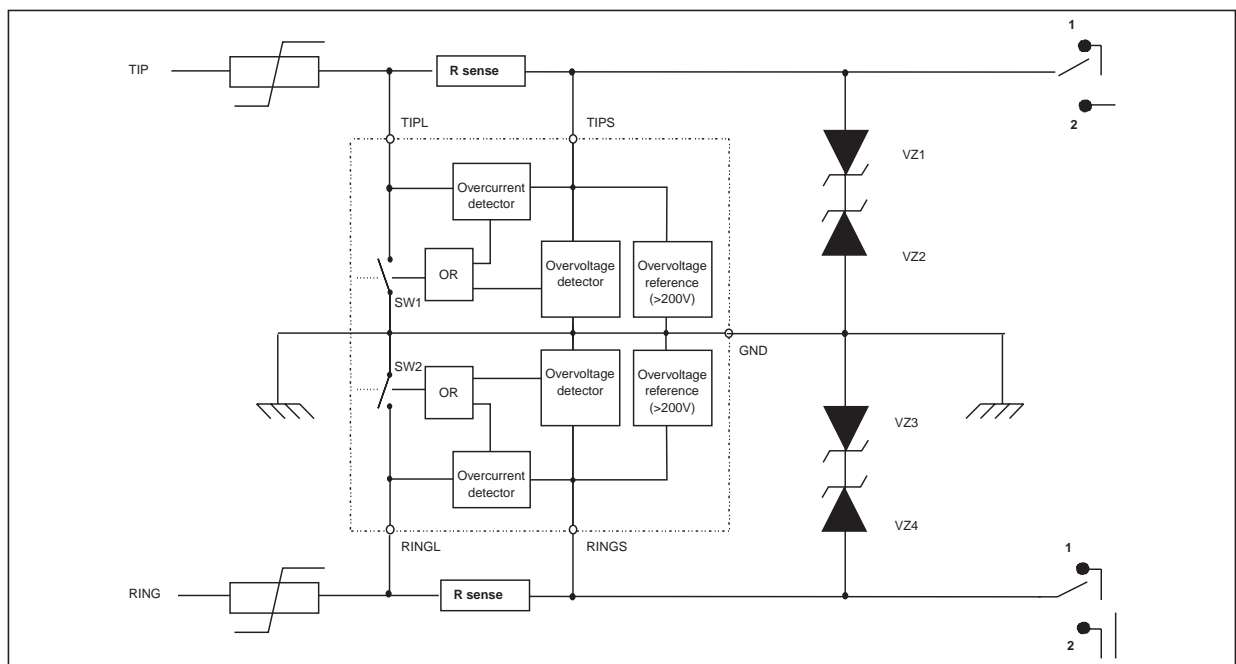
In normal conditions, the CLP30-200B1 operates in region 1 of A1 curve, and is idle.

If an overvoltage occurring between TIP (or RING) and GND reaches the internal overvoltage reference (+/- 200V), the CLP30-200B1 acts and the line is short-circuited to GND. At this time the operating point moves to region 2 for positive surges (region 3 for negative surges). Once the surge current disappears, the device returns to its initial state (region 1).

For surges occurring between TIP and RING, the CLP30-200B1 acts in the same way. This means that the CLP30-200B1 ensures a tripolar protection.

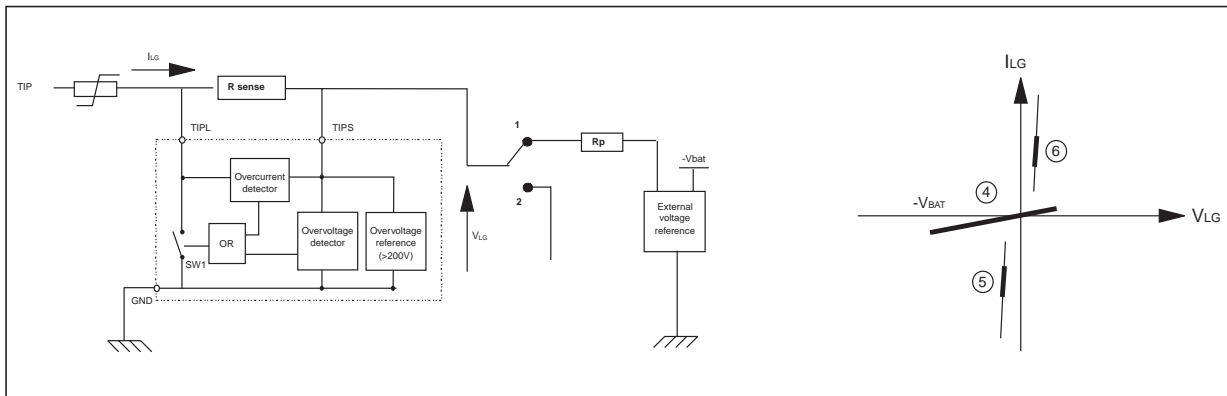
When used alone, the CLP30-200B1 acts at the internal overvoltage reference level (+/- 200 V). Furthermore, it is possible to adjust this threshold level to a lower voltage by using up to 4 fixed external voltage reference ( $V_{Z1}$  to  $V_{Z4}$ ) (see fig.5).

Fig.5 : Methode to adjust the reference voltage.



2.4 Speech mode

Fig.6 : Switching by current during speech mode.



In speech mode (Ring relay in position 1), the protection is provided by the combination of both CLP30-200B1 and the external voltage reference device (for example LCP1511D).

In normal conditions, the working point of this circuit is located in region 4 of **A2** curve : the CLP30-200B1 is idle.

When a surge occurs on the line, the external voltage reference device clamps at GND or  $-V_{bat}$  respectively for positive and negative surges. This generates a current which is detected by  $R_{SENSE}$  and causes the protection to act : the line is short-circuited to GND. The operating point moves to region 6 for positive surges or region 5 for negative surges.

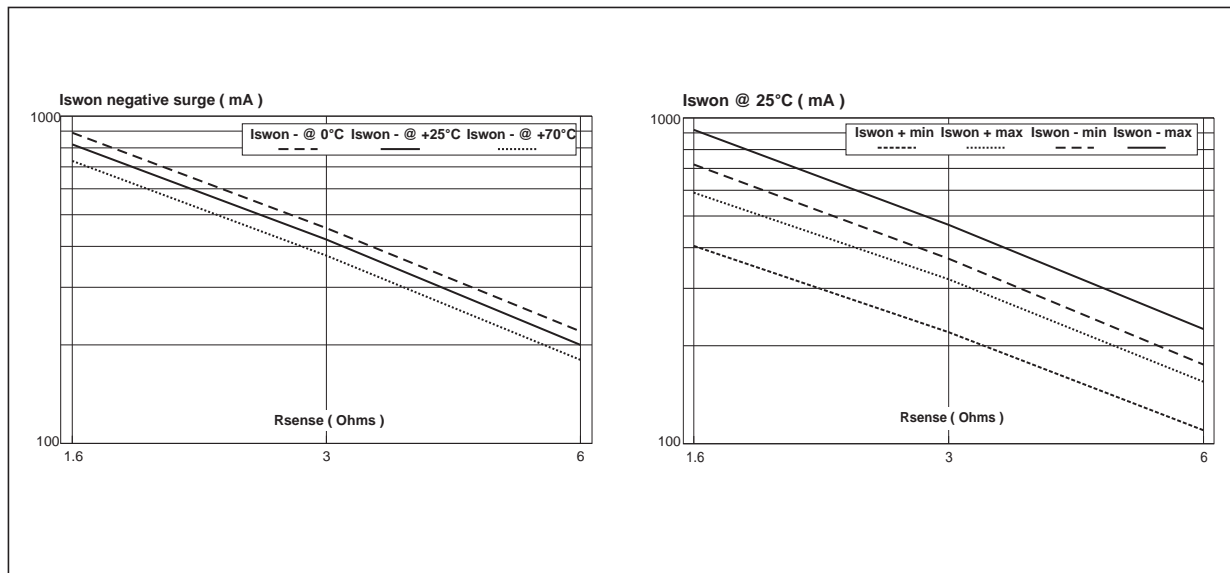
Once the surge current falls below the switching-off current  $I_{SWOFF}$ , the CLP30-200B1 returns to its initial state (region 4).

Furthermore, the CLP30-200B1 switches when an overvoltage, either positive or negative, occurs either :

- simultaneously on both TIP and RING lines versus GND.
- between TIP and RING.
- on TIP (or RING) versus GND.

The choice of the switching-on current is function of the  $R_{SENSE}$  resistors.

**Fig . 7a and 7b :** Switching-on current versus  $R_{SENSE}$



This current (typically above 150 mA) should not activate the protection device CLP30-200B1.

Therefore the level of activation is to be chosen just below this limit (typically 200mA). This level is adjusted through  $R_{SENSE}$ .

Figures 7a and 7b enable the designers to choose the right  $R_{SENSE}$  value.

**Example:** The choice of  $R_{SENSE} = 3 \Omega$  ensures a negative triggering of -280 mA min and -380mA max. In this case, the positive triggering will be 220mA min and 320mA max.

Thanks to the CLP30-200B1 topology, the surge current in the line is reduced after it.

Because the remaining surge energy is low, the power ratings of  $R_P$ , the relay contacts and the external voltage reference device may be kept low. This results in a significant cost reduction for the whole system.

## CLP30-200B1

### ABSOLUTE MAXIMUM RATINGS ( $R_{SENSE} = 3 \Omega, T_{amb} = 25^{\circ}\text{C}$ )

Symbol	Parameter	Value	Unit	
$I_{PP}$	Line to GND peak pulse current 10/1000 $\mu\text{s}$ (open circuit voltage wave shape 10/1000 $\mu\text{s}$ ) 5/310 $\mu\text{s}$ (open circuit voltage wave shape 10/700 $\mu\text{s}$ )	30	A	
		45		
$I_{TSM}$	Non repetitive surge peak on-state current F = 50 Hz	$t_p = 10 \text{ ms}$	8.5	A
		$t_p = 200 \text{ ms}$	4.5	
		$t_p = 1 \text{ s}$	3.5	
$T_{stg}$ $T_j$	Storage temperature range Maximum junction temperature	-40 to +150	$^{\circ}\text{C}$	
		150		
$T_L$	Lead temperature for soldering during 10 s.	260	$^{\circ}\text{C}$	

### ELECTRICAL CHARACTERISTICS ( $R_{SENSE} = 3 \Omega$ , and $T_{amb} = 25^{\circ}\text{C}$ )

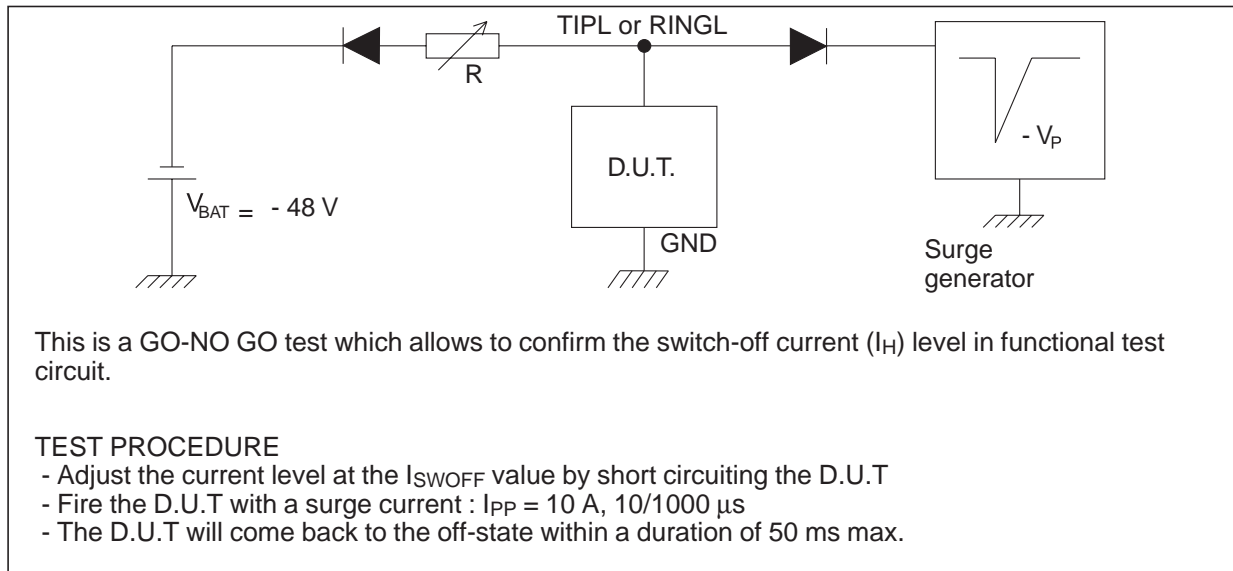
Symbol	Parameter	Test conditions	Min	Max	Unit
$I_{LGL}$	Line to GND leakage current	$V_{LG} = 200 \text{ V}$ Measured between TIP (or RING) and GND		10	$\mu\text{A}$
$V_{LG}$	Line to GND operating voltage		200		V
$V_{SWON}$	Line to GND voltage at SW1 or SW2 switching-on	Measured at 50 Hz between TIPL (or RINGL) and GND, one cycle		290	V
$I_{SWOFF}$	Line to GND negative current at SW1 or SW2 switching-off	Refer to test circuit fig 9	150		mA
$I_{SWON}$	Line current at SW1 or SW2 switching-on	Positive surge	220	320	mA
		Negative surge	370	470	
C	Line to GND capacitance	$V_{LG} = 0\text{V}$ $V_{OSC} = 200\text{mV}_{RMS}$ F = 1MHz		100	pF

### THERMAL RESISTANCE

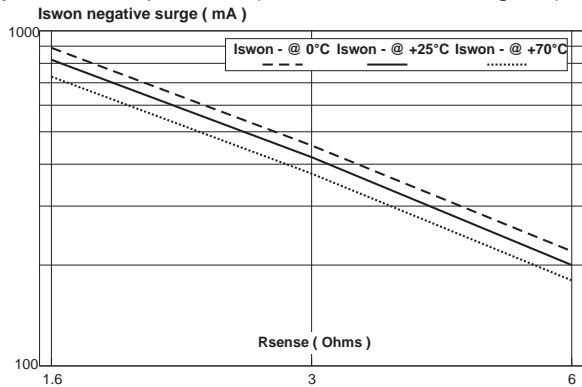
Symbol	Parameter	Value	Unit
$R_{th(j-a)}$	Junction to ambient	170	$^{\circ}\text{C}/\text{W}$



**Fig. 8 : TEST CIRCUIT FOR I<sub>SWOFF</sub> PARAMETER : GO - NO GO TEST**

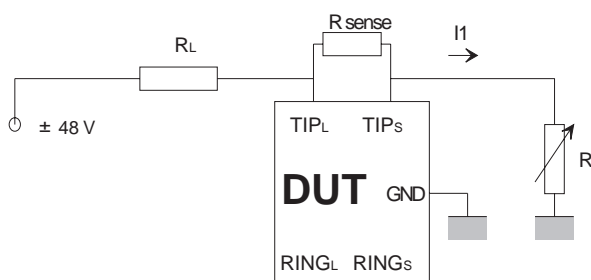


**Fig. 9 : Typical variation of switching-on current (positive or negative) versus R<sub>SENSE</sub> resistor and junction temperature (see test condition Fig. 11).**

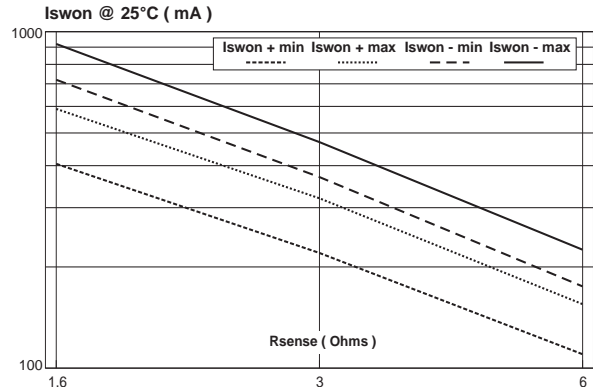


**Fig. 11 : I<sub>SWON</sub> MEASUREMENT**

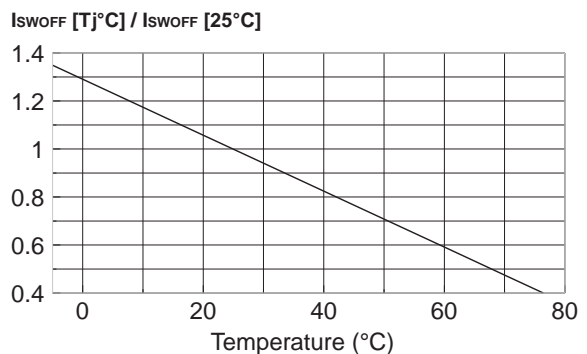
- $I_{SWON} = I_1$  when the CLP30-200B1 switches on ( $I_1$  is progressively increased using R)
- Both TIP and RING sides of the CLP30-200B1 are checked
- $R_L = 10 \Omega$ .



**Fig. 10 : Variation of switching-on current versus R<sub>SENSE</sub> at 25 °C.**

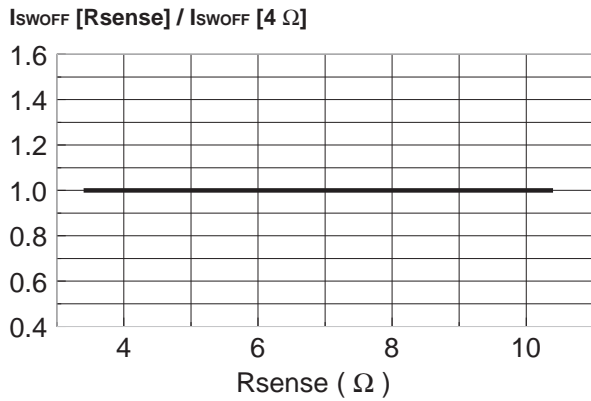


**fig. 12 : Relative variation of switching-off current versus junction temperature (for R<sub>SENSE</sub> between 3 and 10 Ω).**

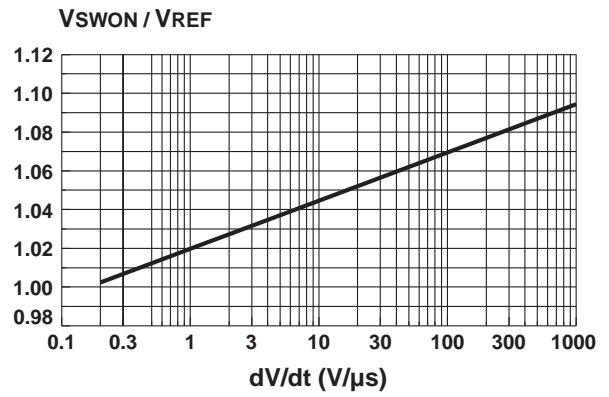


**CLP30-200B1**

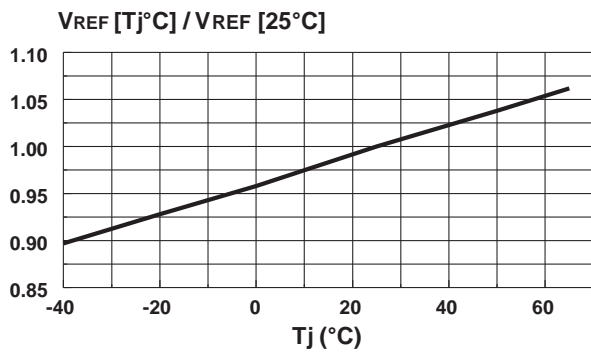
**Fig. 13 :** Relative variation of switching-off current versus  $R_{SENSE}$  (between 3 and 10  $\Omega$ ).



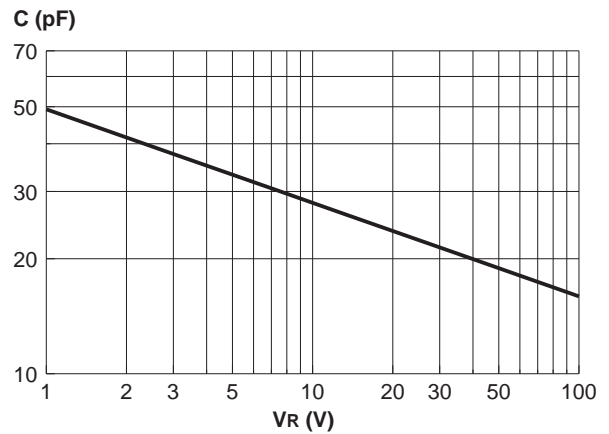
**Fig. 14 :** Relative variation of switching-on voltage versus  $dV/dt$  with an external resistor of 3  $\Omega$ .



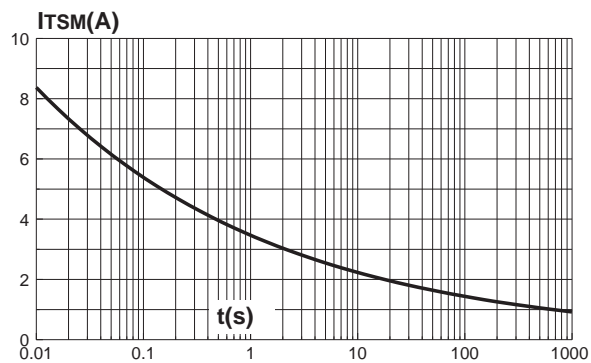
**Fig. 15 :** Relative variation of internal reference voltage versus junction temperature ( $I_{LG} = 1mA$ ).



**Fig. 16 :** Capacitance (TIP/GND) versus applied voltage (typical values).



**Fig. 17 :** Surge peak current versus overload duration (maximum values).



**PACKAGE MECHANICAL DATA**  
**SO8 plastic**

REF.	DIMENSIONS					
	Millimetres			Inches		
	Min.	Typ.	Max.	Min.	Typ.	Max.
A			1.75			0.069
a1	0.1		0.25	0.004		0.010
a2			1.65			0.065
a3	0.65		0.85	0.025		0.033
b	0.35		0.48	0.014		0.019
b1	0.19		0.25	0.007		0.010
C	0.25	0.50	0.50	0.010		0.020
c1	45° (typ)					
D	4.8		5.0	0.189		0.197
E	5.8		6.2	0.228		0.244
e		1.27			0.050	
e3		3.81			0.150	
F	3.8		4.0	0.15		0.157
L	0.4		1.27	0.016		0.050
M			0.6			0.024
S	8° (max)					

**MARKING**

Ordering code	Marking	Package	Weight	Base qty	Delivery mode
CLP30-200B1	CLP30	SO-8	0.08g	100	Tube
CLP30-200B1RL	CLP30	SO-8	0.08g	2500	Tape & Reel

Information furnished is believed to be accurate and reliable. However, STMicroelectronics assumes no responsibility for the consequences of use of such information nor for any infringement of patents or other rights of third parties which may result from its use. No license is granted by implication or otherwise under any patent or patent rights of STMicroelectronics. Specifications mentioned in this publication are subject to change without notice. This publication supersedes and replaces all information previously supplied. STMicroelectronics products are not authorized for use as critical components in life support devices or systems without express written approval of STMicroelectronics.

The ST logo is a registered trademark of STMicroelectronics

© 1999 STMicroelectronics - Printed in Italy - All rights reserved.

STMicroelectronics GROUP OF COMPANIES

Australia - Brazil - China - Finland - France - Germany - Hong Kong - India - Italy - Japan - Malaysia  
 Malta - Morocco - Singapore - Spain - Sweden - Switzerland - United Kingdom - U.S.A.

<http://www.st.com>