

February 1988

## CD4723BM/CD4723BC Dual 4-Bit Addressable Latch CD4724BM/CD4724BC 8-Bit Addressable Latch

### General Description

The CD4723B is a dual 4-bit addressable latch with common control inputs, including two address inputs (A0, A1), an active low enable input ( $\bar{E}$ ), and an active high clear input (CL). Each latch has a data input (D) and four outputs (Q0–Q3). The CD4724B is an 8-bit addressable latch with three address inputs (A0–A2), an active low enable input ( $\bar{E}$ ), active high clear input (CL), a data input (D) and eight outputs (Q0–Q7).

Data is entered into a particular bit in the latch when that is addressed by the address inputs and the enable ( $\bar{E}$ ) is low. Data entry is inhibited when enable ( $\bar{E}$ ) is high.

When clear (CL) and enable ( $\bar{E}$ ) are high, all outputs are low. When clear (CL) is high and enable ( $\bar{E}$ ) is low, the channel demultiplexing occurs. The bit that is addressed has an active output which follows the data input while all unaddressed bits are held low. When operating in the address-

able latch mode ( $\bar{E} = CL = \text{low}$ ), changing more than one bit of the address could impose a transient wrong address. Therefore, this should only be done while in the memory mode ( $\bar{E} = \text{high}, CL = \text{low}$ ).

### Features

- Wide supply voltage range 3.0V to 15V
- High noise immunity 0.45  $V_{DD}$  (typ.)
- Low power TTL compatibility fan out of 2 driving 74L or 1 driving 74LS
- Serial to parallel capability
- Storage register capability
- Random (addressable) data entry
- Active high demultiplexing capability
- Common active high clear

### Connection Diagrams

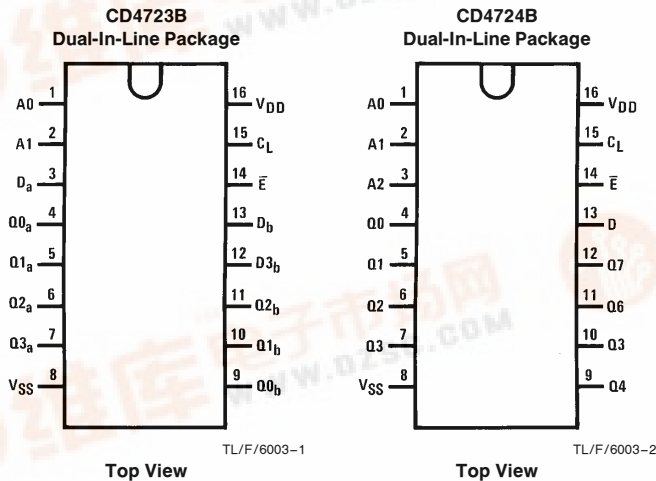

Order Number CD4723B or CD4724B

### Truth Table

Mode Selection				
$\bar{E}$	CL	Addressed Latch	Unaddressed Latch	Mode
L	L	Follows Data	Holds Previous Data	Addressable Latch
H	L	Hold Previous Data	Holds Previous Data	Memory
L	H	Follows Data	Reset to "0"	Demultiplexer
H	H	Reset to "0"	Reset to "0"	Clear

CD4723BM/CD4723BC Dual 4-Bit Addressable Latch  
CD4724BM/CD4724BC 8-Bit Addressable Latch



## Absolute Maximum Ratings (Notes 1 & 2)

If Military/Aerospace specified devices are required, please contact the National Semiconductor Sales Office/Distributors for availability and specifications.

DC Supply Voltage ( $V_{DD}$ )	–0.5V to +18 $V_{DC}$
Input Voltage ( $V_{IN}$ )	–0.5V to $V_{DD}$ + 0.5 $V_{DC}$
Storage Temperature ( $T_S$ )	–65°C to +150°C
Power Dissipation ( $P_D$ )	
Dual-In-Line	700 mW
Small Outline	500 mW
Lead Temperature ( $T_L$ )	
(Soldering, 10 seconds)	260°C

## Recommended Operating Conditions (Note 2)

DC Supply Voltage ( $V_{DD}$ )	3.0V to 15 $V_{DC}$
Input Voltage ( $V_{IN}$ )	0V to $V_{DD}$ $V_{DC}$
Operating Temperature Range ( $T_A$ )	
CD4723BM/CD4724BM	–55°C to +125°C
CD4723BC/CD4724BC	–40°C to +85°C

## DC Electrical Characteristics CD4723BM/CD4724BM (Note 2)

Symbol	Parameter	Conditions	–55°C		+25°C			+125°C		Units
			Min	Max	Min	Typ	Max	Min	Max	
$I_{DD}$	Quiescent Device Current	$V_{DD} = 5V$		5.0		0.02	5.0		150	$\mu A$
		$V_{DD} = 10V$		10		0.02	10		300	$\mu A$
		$V_{DD} = 15V$		20		0.02	20		600	$\mu A$
$V_{OL}$	Low Level Output Voltage	$ I_O  \leq 1 \mu A$								
		$V_{DD} = 5V$		0.05		0	0.05		0.05	V
		$V_{DD} = 10V$		0.05		0	0.05		0.05	V
		$V_{DD} = 15V$		0.05		0	0.05		0.05	V
$V_{OH}$	High Level Output Voltage	$ I_O  \leq 1 \mu A$								
		$V_{DD} = 5V$	4.95		4.95	5.0		4.95		V
		$V_{DD} = 10V$	9.95		9.95	10		9.95		V
		$V_{DD} = 15V$	14.95		14.95	15		14.95		V
$V_{IL}$	Low Level Input Voltage	$V_{DD} = 5V, V_O = 0.5V$ or 4.5V		1.5		2.25	1.5		1.5	V
		$V_{DD} = 10V, V_O = 1V$ or 9V		3.0		4.5	3.0		3.0	V
		$V_{DD} = 15V, V_O = 1.5V$ or 13.5V		4.0		6.75	4.0		4.0	V
$V_{IH}$	High Level Input Voltage	$V_{DD} = 5V, V_O = 0.5V$ or 4.5V	3.5		3.5	2.75		3.5		V
		$V_{DD} = 10V, V_O = 1V$ or 9V	7.0		7.0	5.5		7.0		V
		$V_{DD} = 15V, V_O = 1.5V$ or 13.5V	11.0		11.0	8.25		11.0		V
$I_{OL}$	Low Level Output Current (Note 3)	$V_{DD} = 5V, V_O = 0.4V$	0.64		0.51	0.88		0.36		mA
		$V_{DD} = 10V, V_O = 0.5V$	1.6		1.3	2.25		0.9		mA
		$V_{DD} = 15V, V_O = 1.5V$	4.2		3.4	8.8		2.4		mA
$I_{OH}$	High Level Output Current (Note 3)	$V_{DD} = 5V, V_O = 4.6V$	–0.64		–0.51	–0.88		–0.36		mA
		$V_{DD} = 10V, V_O = 9.5V$	–1.6		–1.3	–2.25		–0.9		mA
		$V_{DD} = 15V, V_O = 13.5V$	–4.2		–3.4	–8.8		–2.4		mA
$I_{IN}$	Input Current	$V_{DD} = 15V, V_{IN} = 0V$		–0.1		$-10^{-5}$	–0.1		–1.0	$\mu A$
		$V_{DD} = 15V, V_{IN} = 15V$		0.1		$10^{-5}$	0.1		1.0	$\mu A$

**Note 1:** "Absolute Maximum Ratings" are those values beyond which the safety of the device cannot be guaranteed; they are not meant to imply that the devices should be operated at these limits. The tables of "Recommended Operating Conditions" and "Electrical Characteristics" provide conditions for actual device operation.

**Note 2:**  $V_{SS} = 0V$  unless otherwise specified.

**Note 3:**  $I_{OL}$  and  $I_{OH}$  are tested one output at a time.

## DC Electrical Characteristics CD4723BC/CD4724BC (Note 2)

Symbol	Parameter	Conditions	-40°C		+25°C			+85°C		Units
			Min	Max	Min	Typ	Max	Min	Max	
I <sub>DD</sub>	Quiescent Device Current	V <sub>DD</sub> = 5V		20		0.02	20		150	μA
		V <sub>DD</sub> = 10V		40		0.02	40		300	μA
		V <sub>DD</sub> = 15V		80		0.02	80		600	μA
V <sub>OL</sub>	Low Level Output Voltage	I <sub>O</sub>   ≤ 1 μA								
		V <sub>DD</sub> = 5V		0.05		0	0.05		0.05	V
		V <sub>DD</sub> = 10V		0.05		0	0.05		0.05	V
		V <sub>DD</sub> = 15V		0.05		0	0.05		0.05	V
V <sub>OH</sub>	High Level Output Voltage	I <sub>O</sub>   ≤ 1 μA								
		V <sub>DD</sub> = 5V	4.95		4.95	5.0		4.95		V
		V <sub>DD</sub> = 10V	9.95		9.95	10		9.95		V
		V <sub>DD</sub> = 15V	14.95		14.95	15		14.95		V
V <sub>IL</sub>	Low Level Input Voltage	V <sub>DD</sub> = 5V, V <sub>O</sub> = 0.5V or 4.5V		1.5		2.25	1.5		1.5	V
		V <sub>DD</sub> = 10V, V <sub>O</sub> = 1V or 9V		3.0		4.5	3.0		3.0	V
		V <sub>DD</sub> = 15V, V <sub>O</sub> = 1.5V or 13.5V		4.0		6.75	4.0		4.0	V
V <sub>IH</sub>	High Level Input Voltage	V <sub>DD</sub> = 5V, V <sub>O</sub> = 0.5V or 4.5V	3.5		3.5	2.75		3.5		V
		V <sub>DD</sub> = 10V, V <sub>O</sub> = 1V or 9V	7.0		7.0	5.5		7.0		V
		V <sub>DD</sub> = 15V, V <sub>O</sub> = 1.5V or 13.5V	11.0		11.0	8.25		11.0		V
I <sub>OL</sub>	Low Level Output Current (Note 3)	V <sub>DD</sub> = 5V, V <sub>O</sub> = 0.4V	0.52		0.44	0.88		0.36		mA
		V <sub>DD</sub> = 10V, V <sub>O</sub> = 0.5V	1.3		1.1	2.25		0.9		mA
		V <sub>DD</sub> = 15V, V <sub>O</sub> = 1.5V	3.6		3.0	8.8		2.4		mA
I <sub>OH</sub>	High Level Output Current (Note 3)	V <sub>DD</sub> = 5V, V <sub>O</sub> = 4.6V	-0.52		-0.44	-0.88		-0.36		mA
		V <sub>DD</sub> = 10V, V <sub>O</sub> = 9.5V	-1.3		-1.1	-2.25		-0.9		mA
		V <sub>DD</sub> = 15V, V <sub>O</sub> = 13.5V	-3.6		-3.0	-8.8		-2.4		mA
I <sub>IN</sub>	Input Current	V <sub>DD</sub> = 15V, V <sub>IN</sub> = 0V		-0.30		-10 <sup>-5</sup>	-0.30		-1.0	μA
		V <sub>DD</sub> = 15V, V <sub>IN</sub> = 15V		0.30		10 <sup>-5</sup>	0.30		1.0	μA

**Note 1:** "Absolute Maximum Ratings" are those values beyond which the safety of the device cannot be guaranteed; they are not meant to imply that the devices should be operated at these limits. The tables of "Recommended Operating Conditions" and "Electrical Characteristics" provide conditions for actual device operation.

**Note 2:** V<sub>SS</sub> = 0V unless otherwise specified.

**Note 3:** I<sub>OL</sub> and I<sub>OH</sub> are tested one output at a time.

## AC Electrical Characteristics\*

$T_A = 25^\circ\text{C}$ ,  $C_L = 50\text{ pF}$ ,  $R_L = 200\text{ k}$ , Input  $t_r = t_f = 20\text{ ns}$ , unless otherwise noted

Symbol	Parameter	Conditions	Min	Typ	Max	Units
$t_{PHL}$ , $t_{PLH}$	Propagation Delay Data to Output	$V_{DD} = 5\text{V}$		200	400	ns
		$V_{DD} = 10\text{V}$		75	150	ns
		$V_{DD} = 15\text{V}$		50	100	ns
$t_{PLH}$ , $t_{PHL}$	Propagation Delay Enable to Output	$V_{DD} = 5\text{V}$		200	400	ns
		$V_{DD} = 10\text{V}$		80	160	ns
		$V_{DD} = 15\text{V}$		60	120	ns
$t_{PHL}$	Propagation Delay Clear to Output	$V_{DD} = 5\text{V}$		175	350	ns
		$V_{DD} = 10\text{V}$		80	160	ns
		$V_{DD} = 15\text{V}$		65	130	ns
$t_{PLH}$ , $t_{PHL}$	Propagation Delay Address to Output	$V_{DD} = 5\text{V}$		225	450	ns
		$V_{DD} = 10\text{V}$		100	200	ns
		$V_{DD} = 15\text{V}$		75	150	ns
$t_{THL}$ , $t_{TLH}$	Transition Time (Any Output)	$V_{DD} = 5\text{V}$		100	200	ns
		$V_{DD} = 10\text{V}$		50	100	ns
		$V_{DD} = 15\text{V}$		40	80	ns
$T_{WH}$ , $T_{WL}$	Minimum Data Pulse Width	$V_{DD} = 5\text{V}$		100	200	ns
		$V_{DD} = 10\text{V}$		50	100	ns
		$V_{DD} = 15\text{V}$		40	80	ns
$t_{WH}$ , $t_{WL}$	Minimum Address Pulse Width	$V_{DD} = 5\text{V}$		200	400	ns
		$V_{DD} = 10\text{V}$		100	200	ns
		$V_{DD} = 15\text{V}$		65	125	ns
$t_{WH}$	Minimum Clear Pulse Width	$V_{DD} = 5\text{V}$		75	150	ns
		$V_{DD} = 10\text{V}$		40	75	ns
		$V_{DD} = 15\text{V}$		25	50	ns
$t_{SU}$	Minimum Setup Time Data to E	$V_{DD} = 5\text{V}$		40	80	ns
		$V_{DD} = 10\text{V}$		20	40	ns
		$V_{DD} = 15\text{V}$		15	30	ns
$t_H$	Minimum Hold Time Data to E	$V_{DD} = 5\text{V}$		60	120	ns
		$V_{DD} = 10\text{V}$		30	60	ns
		$V_{DD} = 15\text{V}$		25	50	ns
$t_{SU}$	Minimum Setup Time Address to E	$V_{DD} = 5\text{V}$		-15	50	ns
		$V_{DD} = 10\text{V}$		0	30	ns
		$V_{DD} = 15\text{V}$		0	20	ns
$t_H$	Minimum Hold Time Address to E	$V_{DD} = 5\text{V}$		-50	15	ns
		$V_{DD} = 10\text{V}$		-20	10	ns
		$V_{DD} = 15\text{V}$		-15	5	ns
$C_{PD}$	Power Dissipation Capacitance	Per Package (Note 4)		100		pF
$C_{IN}$	Input Capacitance	Any Input		5.0	7.5	pF

\*AC Parameters are guaranteed by DC correlated testing.

**Note 1:** "Absolute Maximum Ratings" are those values beyond which the safety of the device cannot be guaranteed; they are not meant to imply that the devices should be operated at these limits. The tables of "Recommended Operating Conditions" and "Electrical Characteristics" provide conditions for actual device operation.

**Note 2:**  $V_{SS} = 0\text{V}$  unless otherwise specified.

**Note 3:**  $I_{OL}$  and  $I_{OH}$  are tested one output at a time.

**Note 4:** Dynamic power dissipation ( $P_D$ ) is given by:  $P_D = (C_{PD} + C_L) V_{CC}^2 f + P_Q$ ; where  $C_L$  = load capacitance;  $f$  = frequency of operation; for further details, see Application Note AN-90, "54C/74C Family Characteristics".

# Logic Diagrams

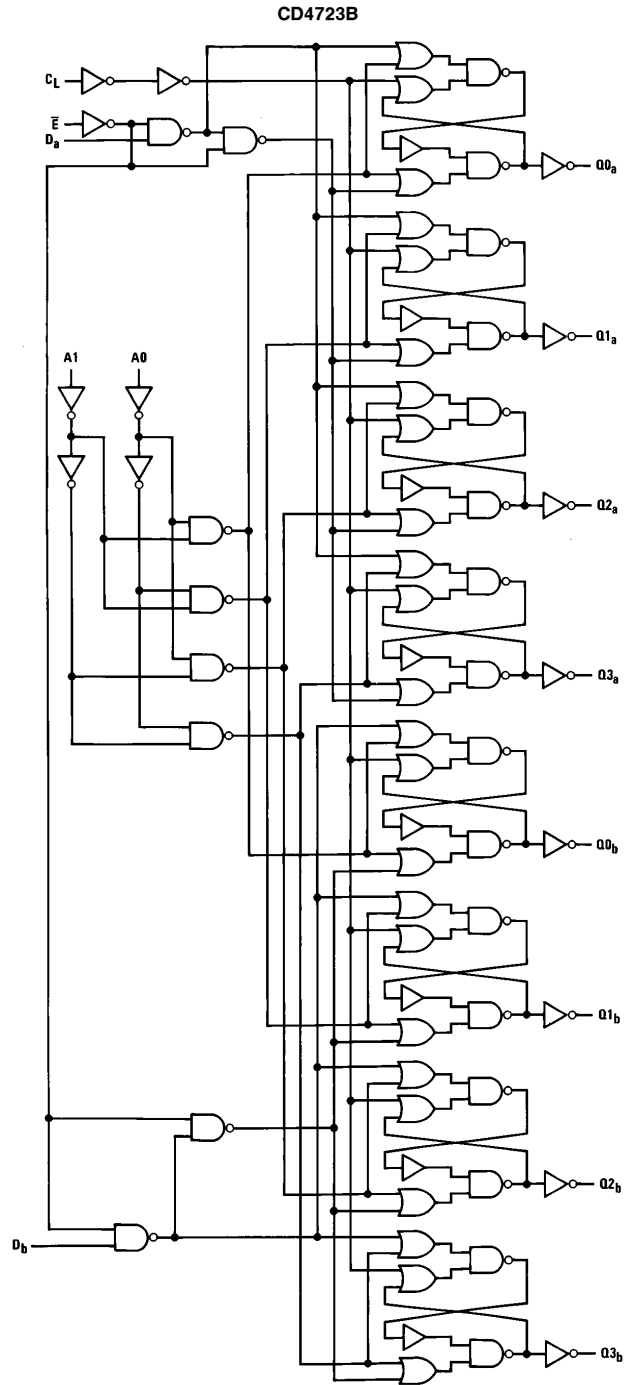

TL/F/6003-3

Logic Diagrams (Continued)

CD4724B

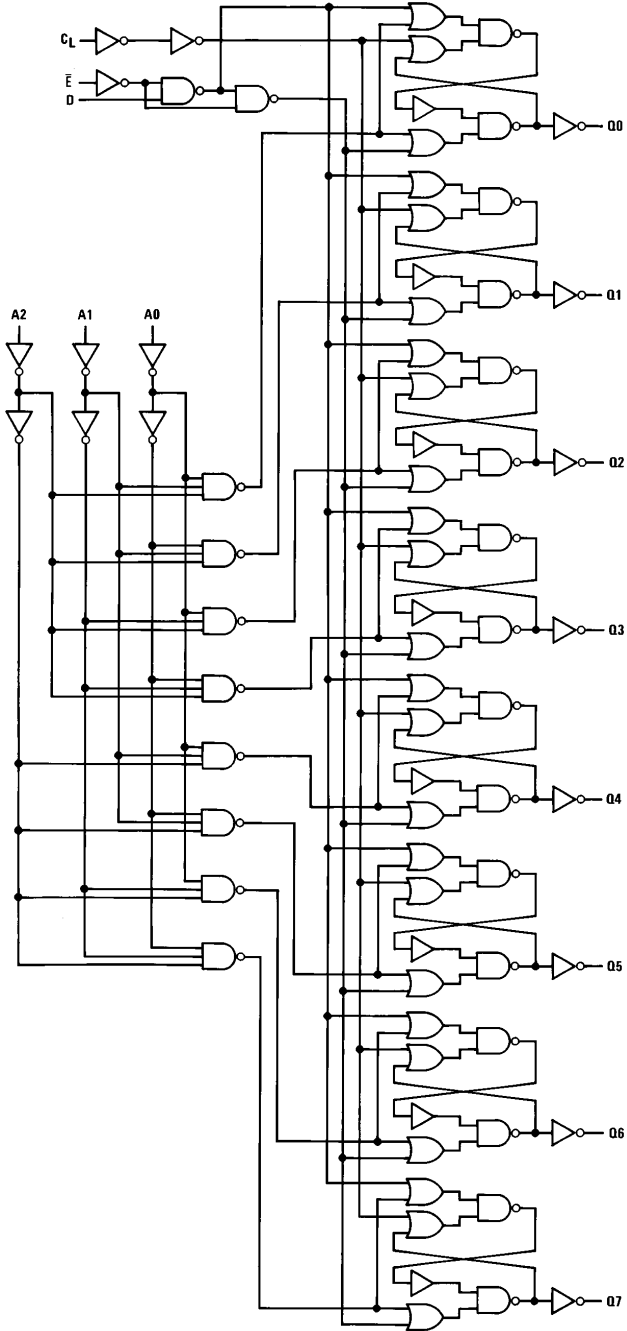

TL/F/6003-4

# Switching Time Waveforms

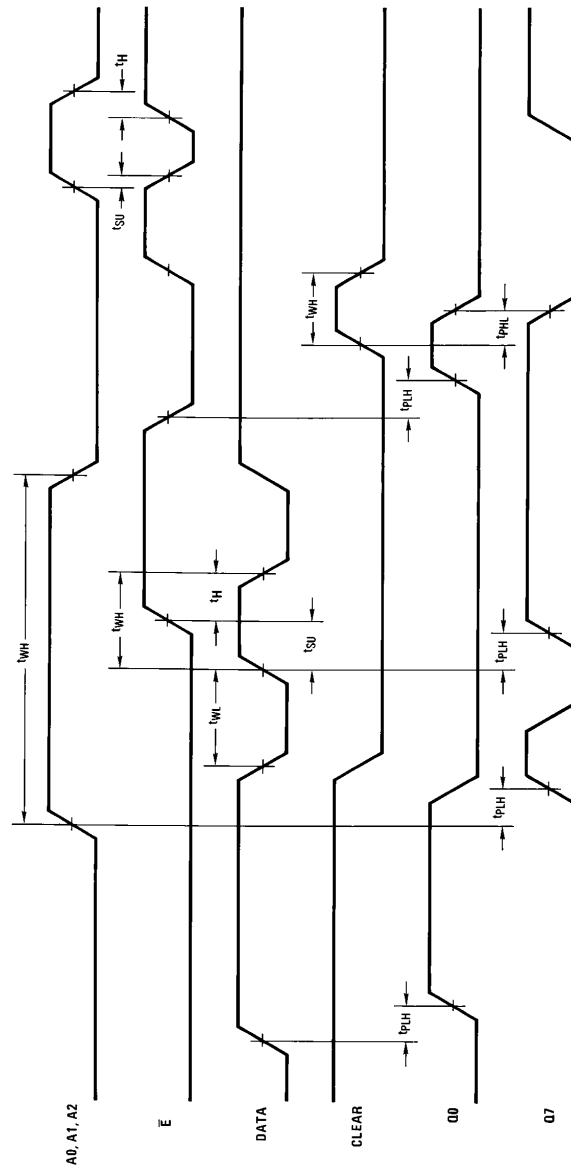

TL/F/6003-5

**CD4723BM/CD4723BC Dual 4-Bit Addressable Latch**  
**CD4724BM/CD4724BC 8-Bit Addressable Latch**

**Physical Dimensions** inches (millimeters)

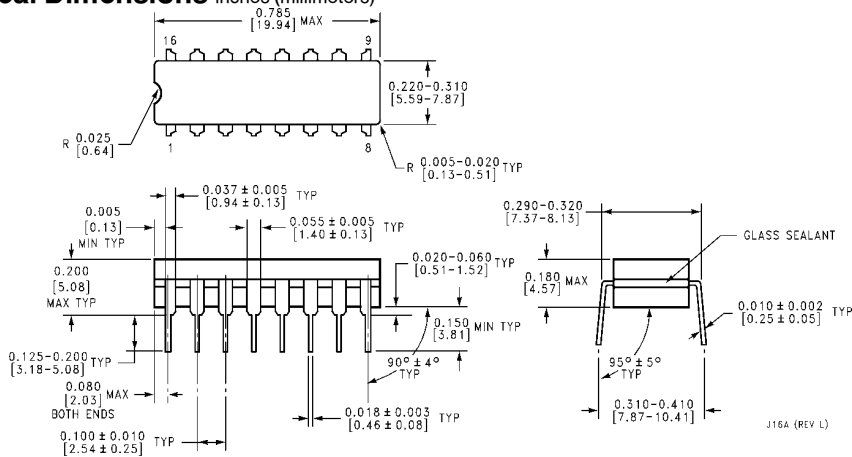

**Ceramic Dual-In-Line Package (J)**  
**Order Number CD4723BMJ, CD4723BCJ, CD4724BMJ or CD4724BCJ**  
**NS Package Number J16A**

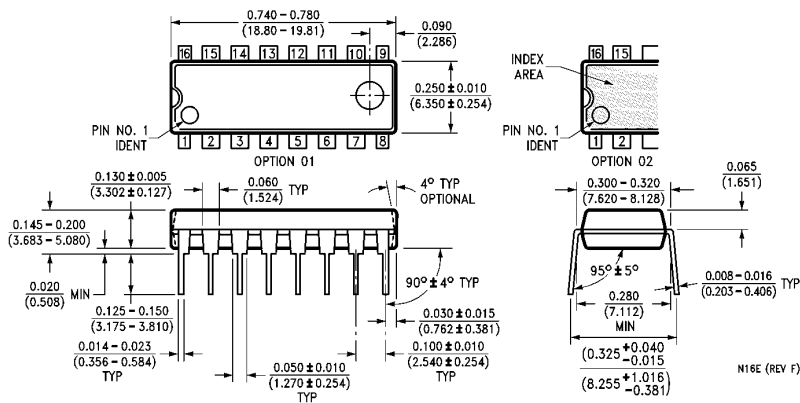

**Molded Dual-In-Line Package (N)**  
**Order Number CD4723BMN, CD4723BCN, CD4724BMN or CD4724BCN**  
**NS Package Number N16E**

**LIFE SUPPORT POLICY**

NATIONAL'S PRODUCTS ARE NOT AUTHORIZED FOR USE AS CRITICAL COMPONENTS IN LIFE SUPPORT DEVICES OR SYSTEMS WITHOUT THE EXPRESS WRITTEN APPROVAL OF THE PRESIDENT OF NATIONAL SEMICONDUCTOR CORPORATION. As used herein:

1. Life support devices or systems are devices or systems which, (a) are intended for surgical implant into the body, or (b) support or sustain life, and whose failure to perform, when properly used in accordance with instructions for use provided in the labeling, can be reasonably expected to result in a significant injury to the user.
2. A critical component is any component of a life support device or system whose failure to perform can be reasonably expected to cause the failure of the life support device or system, or to affect its safety or effectiveness.



**National Semiconductor Corporation**  
 1111 West Bardin Road  
 Arlington, TX 76017  
 Tel: 1(800) 272-9959  
 Fax: 1(800) 737-7018

**National Semiconductor Europe**  
 Fax: (+49) 0-180-530 85 86  
 Email: cnjwge@tevm2.nsc.com  
 Deutsch Tel: (+49) 0-180-530 85 85  
 English Tel: (+49) 0-180-532 78 32  
 Français Tel: (+49) 0-180-532 93 58  
 Italiano Tel: (+49) 0-180-534 16 80

**National Semiconductor Hong Kong Ltd.**  
 13th Floor, Straight Block,  
 Ocean Centre, 5 Canton Rd.  
 Tsimshatsui, Kowloon  
 Hong Kong  
 Tel: (852) 2737-1600  
 Fax: (852) 2736-9960

**National Semiconductor Japan Ltd.**  
 Tel: 81-043-299-2309  
 Fax: 81-043-299-2408

National does not assume any responsibility for use of any circuitry described, no circuit patent licenses are implied and National reserves the right at any time without notice to change said circuitry and specifications.