



5V/250mA, 5V/100mA Micropower Low Dropout Regulator with ENABLE

Description

The CS8391 is a precision, dual 5V micropower linear voltage regulator. The switched primary output (V_{OUT1}) supplies up to 250mA while the secondary (V_{OUT2}) is capable of supplying 100mA. Both outputs have a maximum dropout voltage of 600mV and low reverse current. Quiescent current drain is typically 150 μ A when supplying 100 μ A from each output.

The ENABLE input provides logic

level control of the primary output. With the primary output disabled, quiescent current drain is typically 100 μ A when supplying 100 μ A from the secondary output.

The CS8391 is extremely robust with protection provided for reverse battery, short circuit, and overtemperature on both outputs.

The CS8391 is available in a 5-lead D²PAK.

Features

- 5V, 250mA Primary Output
- 5V, 100mA Secondary Output
- 3% Tolerance, Both Outputs
- ON/OFF Control for Primary Output
- Low Quiescent Current Drain (100 μ A V_{OUT2})
- Low Reverse Current
- Protection Features
 - Reverse Battery (-15V)
 - Short Circuit
 - Overtemperature

Absolute Maximum Ratings

Input Voltage	-15V to 45V
Power Dissipation	Internally Limited
Operating Temperature Range	-40°C to +125°C
Maximum Junction Temperature	-40°C to +150°C
Storage Temperature Range	-55°C to +150°C
Electrostatic Discharge (Human Body Model)	4kV
Lead Temperature Soldering	
Wave Solder (through hole styles only)	10 sec. max, 260°C peak
Reflow (SMD styles only)	60 sec. max above 183°C, 230°C peak

Block Diagram

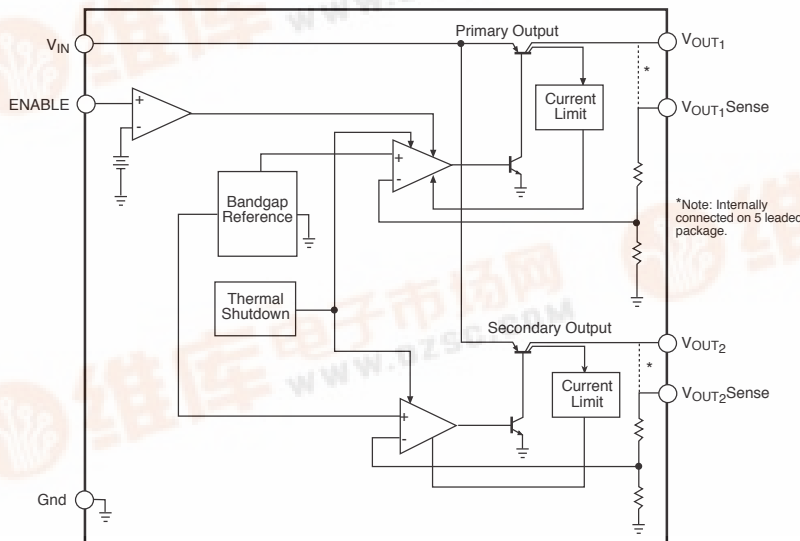

Package Options

5 Lead D²PAK
Tab (Gnd)

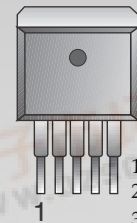

1. V_{IN}
2. V_{OUT1}
3. Gnd
4. V_{OUT2}
5. ENABLE

Consult factory for 8L and 16L SO, 8L and 16L PDIP, 7L D²PAK and 5L TO-220.

Electrical Characteristics: $6V \leq V_{IN} \leq 26V$, $I_{OUT1} = I_{OUT2} = 100\mu A$, $-40^{\circ}C \leq T_C \leq 125^{\circ}C$, $-40^{\circ}C \leq T_J \leq 150^{\circ}C$ unless otherwise specified

PARAMETER	TEST CONDITIONS	MIN	TYP	MAX	UNIT
■ Primary Output Stage (V_{OUT1})					
Output Voltage, V_{OUT1}	$100\mu A \leq I_{OUT1} \leq 250mA$	4.85	5.00	5.15	V
Dropout Voltage	$I_{OUT1} = 250mA$		400	600	mV
	$I_{OUT1} = 100\mu A$		100	150	mV
Line Regulation	$6V \leq V_{IN} \leq 26V$		5	50	mV
Load Regulation	$1mA \leq I_{OUT1} \leq 250mA$, $V_{IN} = 14V$		5	50	mV
Quiescent Current	ENABLE = HIGH, $V_{IN} = 16V$, $I_{OUT1} = 250mA$		22	50	mA
Ripple Rejection	$f = 120Hz$, $I_{OUT1} = 125mA$, $7V \leq V_{IN} \leq 17V$	60	70		dB
Current Limit		260	400		mA
Short Circuit Current Limit	$V_{OUT1} = 0V$, $V_{IN} = 16V$	25			mA
Reverse Current	$V_{OUT1} = 5V$, $V_{IN} = 0V$		100	1500	μA
■ Secondary Output (V_{OUT2})					
Output Voltage, V_{OUT2}	$100\mu A \leq I_{OUT2} \leq 100mA$	4.85	5.00	5.15	V
Dropout Voltage	$I_{OUT2} = 100mA$		400	600	mV
	$I_{OUT2} = 100\mu A$		100	150	mV
Line Regulation	$6V \leq V_{IN} \leq 26V$		5	50	mV
Load Regulation	$100\mu A \leq I_{OUT2} \leq 100mA$, $V_{IN} = 14V$		5	50	mV
Quiescent Current	ENABLE = LOW, $V_{IN} = 12.8V$		100	150	μA
	ENABLE = HIGH, $V_{IN} = 16V$, $I_{OUT2} = 100mA$		8	25	mA
Ripple Rejection	$f = 120Hz$, $I_{OUT2} = 50mA$, $7V \leq V_{IN} \leq 17V$	60	70		dB
Current Limit		105	200		mA
Short Circuit Current Limit	$V_{OUT2} = 0V$, $V_{IN} = 16V$, $I_{OUT1} = 0A$	25			mA
Reverse Current	$V_{OUT2} = 5V$, $V_{IN} = 0V$		100	250	μA
■ Enable Function (ENABLE)					
Input Threshold	ENABLE = LOW, $7V \leq V_{IN} \leq 26V$		1.2	0.8	V
	ENABLE = HIGH, $7V \leq V_{IN} \leq 26V$	2.0	1.2		V
Input Bias Current	$0V \leq V_{ENABLE} \leq 5V$	-2	0	2	μA
■ Protection Circuits					
Overtemperature Threshold	(Guaranteed by Design)	150	180		$^{\circ}C$

Package Lead Description

PACKAGE LEAD #	LEAD SYMBOL	FUNCTION
5 Lead D²PAK		
1	V_{IN}	Supply voltage to IC, usually direct from battery.
2	V_{OUT1}	5V regulated output which is activated by ENABLE input.
3	Gnd	Ground connection.
4	V_{OUT2}	Standby output 5V, 100mA capability; always on.
5	ENABLE	CMOS compatible input lead; switches V_{OUT1} . When ENABLE is high, V_{OUT1} is active.

Definition of Terms

Current Limit

Peak current that can be delivered to the output.

Dropout Voltage

The input-output voltage differential at which the circuit ceases to regulate against further reduction in input voltage. Measured when the output voltage has dropped 100mV from the nominal value obtained at 14V input, dropout voltage is dependent upon load current and junction temperature.

Input Output Differential

The voltage difference between the unregulated input voltage and the regulated output voltage for which the regulator will operate.

Input Voltage

The DC voltage applied to the input terminals with respect to ground.

Line Regulation

The change in output voltage for a change in the input voltage. The measurement is made under conditions of low dissipation or by using pulse techniques such that the average chip temperature is not significantly affected.

Load Regulation

The change in output voltage for a change in load current at constant chip temperature.

Long Term Stability

Output voltage stability under accelerated life-test conditions after 1000 hours with maximum rated voltage and junction temperature.

Quiescent Current

The part of the positive input current that does not contribute to the positive load current. i.e., the regulator ground lead current.

Ripple Rejection

The ratio of the peak-to-peak input ripple voltage to the peak-to-peak output ripple voltage.

Short Circuit Current Limit

Peak current that can be delivered by the output when forced to 0V.

Temperature Stability of V_{OUT}

The percentage change in output voltage for a thermal variation from room temperature to either temperature extreme.

Typical Circuit Waveform

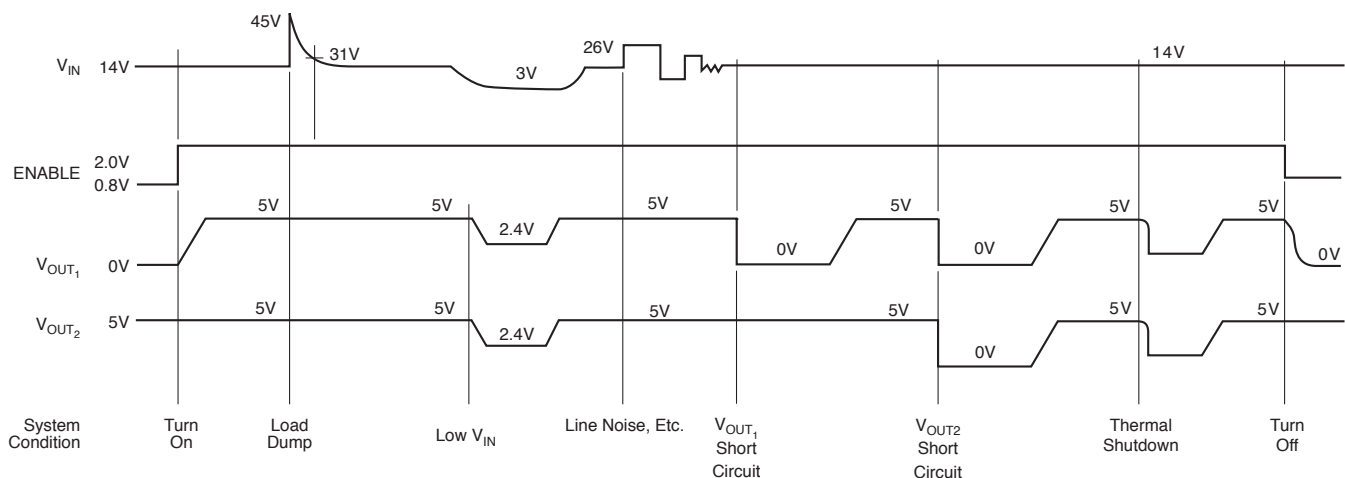

General

The CS8391 is a micropower dual 5V regulator. All bias required to operate the internal circuitry is derived from the standby output, V_{OUT2} . If this output experiences an over current situation and collapses, then V_{OUT1} will also collapse (see timing diagrams).

If there is critical circuitry that must remain active under most conditions it should be connected to V_{OUT2} . Any circuitry that is likely to be subjected to a short circuit, e.g., circuitry outside the module, should be connected to V_{OUT1} .

External Capacitors

Output capacitors are required for stability with the CS8391. Without them, the regulator outputs will oscillate. Actual size and type may vary depending upon the application load and temperature range. Capacitor effective series resistance (ESR) is also a factor in the IC stability. Worst-case is determined at the minimum ambient temperature and maximum load expected.

Output capacitors can be increased in size to any desired value above the minimum. One possible purpose of this would be to maintain the output voltages during brief conditions of negative input transients that might be characteristic of a particular system.

Capacitors must also be rated at all ambient temperatures expected in the system. To maintain regulator stability down to -40°C , capacitors rated at that temperature must be used.

More information on capacitor selection for Smart Regulators™ is available in the Smart Regulator application note, *Compensation for Linear Regulators*.

ENABLE

The ENABLE function controls V_{OUT1} . When ENABLE is high, V_{OUT1} is on. When ENABLE is low, V_{OUT1} is off.

Calculating Power Dissipation
in a Dual Output Linear Regulator

The maximum power dissipation for a dual output regulator (Figure 1) is:

$$\text{PD}(\text{max}) = \{V_{\text{IN}}(\text{max}) - V_{\text{OUT1}}(\text{min})\}I_{\text{OUT1}}(\text{max}) + \{V_{\text{IN}}(\text{max}) - V_{\text{OUT2}}(\text{min})\}I_{\text{OUT2}}(\text{max}) + V_{\text{IN}}(\text{max})I_{\text{Q}} \quad (1)$$

where:

$V_{\text{IN}}(\text{max})$ is the maximum input voltage,

$V_{\text{OUT1}}(\text{min})$ is the minimum output voltage from V_{OUT1} ,

$V_{\text{OUT2}}(\text{min})$ is the minimum output voltage from V_{OUT2} ,

$I_{\text{OUT1}}(\text{max})$ is the maximum output current for the application,

$I_{\text{OUT2}}(\text{max})$ is the maximum output current for the application, and

I_{Q} is the quiescent current the regulator consumes at both $I_{\text{OUT1}}(\text{max})$ and $I_{\text{OUT2}}(\text{max})$.

Once the value of $\text{PD}(\text{max})$ is known, the maximum permissible value of $R_{\theta\text{JA}}$ can be calculated:

$$R_{\theta\text{JA}} = \frac{150^{\circ}\text{C} - T_{\text{A}}}{\text{P}_{\text{D}}} \quad (2)$$

The value of $R_{\theta\text{JA}}$ can then be compared with those in the package section of the data sheet. Those packages with $R_{\theta\text{JA}}$'s less than the calculated value in equation 2 will keep the die temperature below 150°C .

In some cases, none of the packages will be sufficient to dissipate the heat generated by the IC, and an external heat sink will be required.

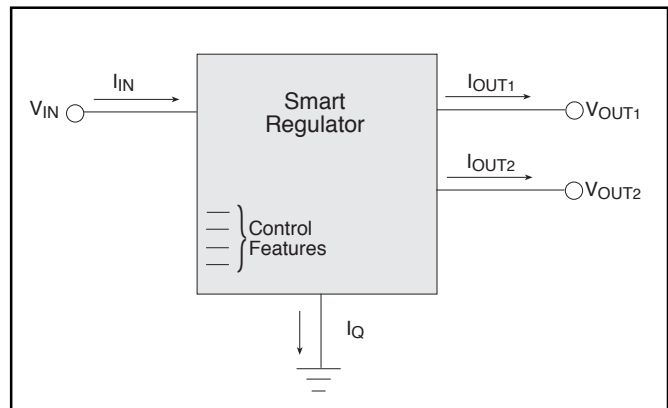

Figure 1: Dual output regulator with key performance parameters labeled.

Heat Sinks

A heat sink effectively increases the surface area of the package to improve the flow of heat away from the IC and into the surrounding air.

Each material in the heat flow path between the IC and the outside environment will have a thermal resistance. Like series electrical resistances, these resistances are summed to determine the value of $R_{\theta\text{JA}}$:

$$R_{\theta\text{JA}} = R_{\theta\text{JC}} + R_{\theta\text{CS}} + R_{\theta\text{SA}} \quad (3)$$

where:

$R_{\theta\text{JC}}$ = the junction-to-case thermal resistance,

$R_{\theta\text{CS}}$ = the case-to-heat sink thermal resistance, and

$R_{\theta\text{SA}}$ = the heat sink-to-ambient thermal resistance.

$R_{\theta\text{JC}}$ appears in the package section of the data sheet. Like $R_{\theta\text{JA}}$, it too is a function of package type. $R_{\theta\text{CS}}$ and $R_{\theta\text{SA}}$ are functions of the package type, heat sink and the interface between them. These values appear in heat sink data sheets of heat sink manufacturers.

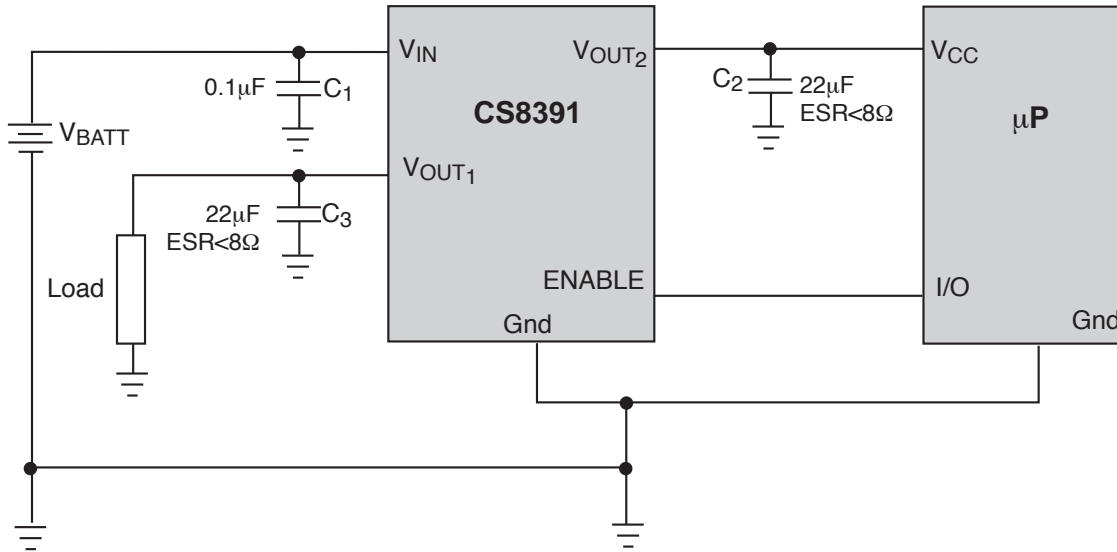

* C1 required if regulator is located far from power supply filter.

** C2 and C3 required for stability. Capacitor must operate at minimum temperature expected during system operations.

