



DS3154DK Quad DS3/E3/STS-1 LIU Demo Kit

www.maxim-ic.com

GENERAL DESCRIPTION

The DS3154DK is an easy-to-use evaluation kit for the DS3154 quad DS3/E3/STS-1 LIU. A surface-mounted DS3154 and careful layout of the analog signal traces provide maximum signal integrity to demonstrate the transmit and receive capabilities of the DS3154. On-board Dallas 8051-compatible microcontroller and included software give point-and-click access to configuration and status registers from a personal computer. LEDs on the board indicate interrupt, loss-of-signal, transmit driver monitor, and PRBS sync status for all four ports. The board provides BNC connectors for the line-side transmit and receive differential pairs and a 50-pin connector for framer interface signals. All LEDs and connectors are clearly labeled with silk-screening to identify associated signals.

DEMO KIT CONTENTS

- DS3154DK Board
- CD-ROM
 - ChipView Software
 - DS3154.def Definition File
 - DS3154DK Data Sheet
 - DS3154 Data Sheet

ORDERING INFORMATION

PART	DESCRIPTION
DS3154DK	DS3154 Demo Kit

FEATURES

- Soldered DS3154 for Best Signal Integrity
- BNC Connectors, Transformers and Termination Passives for All Four LIUs
- Careful Layout for Analog Signal Paths
- Equipment-Side Connector for External Data Source/Sink or External Remote Loopback
- On-Board DS3 and E3 Crystal Oscillators
- DS3154 Configured for CPU Bus Operation for Complete Control Over the Device
- On-Board Dallas Microcontroller and Included Software Provide Point-and-Click Access to the DS3154 Register Set
- LEDs for Interrupt, Loss-of-Signal, Transmit Driver Monitor, and PRBS Sync
- Banana Jack Connectors for V_{DD} and GND Support Use of Lab Power Supplies
- Separate DS3154 V_{DD} to Enable I_{DD} Measurements
- Easy-to-Read Silk Screen Labels Identify the Signals Associated with All Connectors, Jumpers and LEDs

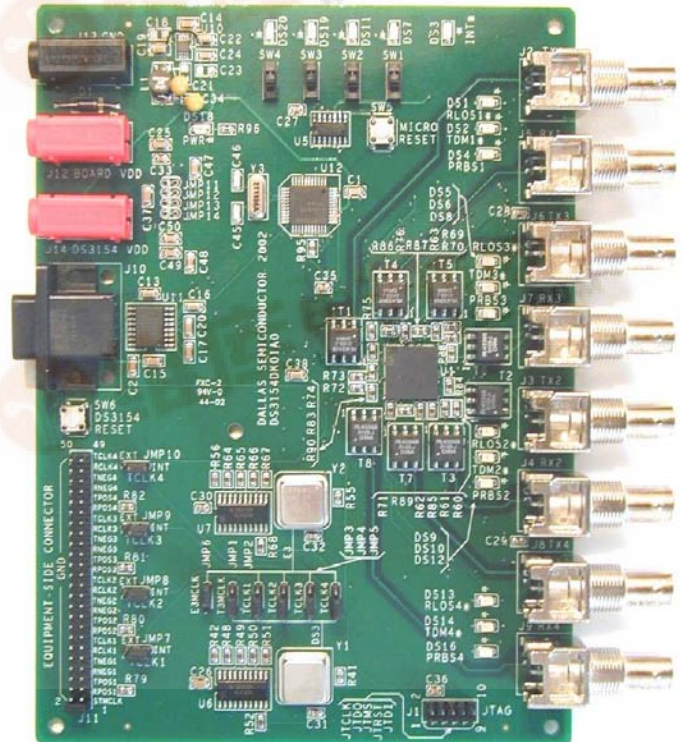

COMPONENT LIST

DESIGNATION	QTY	DESCRIPTION	MANUFACTURER	PART
U1	1	Quad DS3/E3/STS1 LIU, 144-pin BGA	Dallas Semiconductor	DS3154
U12	1	High-speed microcontroller, 44-pin TQFP	Dallas Semiconductor	DS87C520-ECL
U11	1	Dual RS232 XMITR/receiver, 16-pin SO (300-mil)	Dallas Semiconductor	DS232AS
U10		SO, 8-pin, step-up DC-DC converter 0.5A limit	Maxim	MAX1675EUA
U6, U7	2	Oct buffer/driver, 3.3V SOP, 20-pin narrow	Texas Instruments	SN74ALVC244NSR
U2, U4, U5	3	IC, hex inverter, SO	Toshiba	TC74HC04AFN
C1, C2, C7, C8, C14, C24, C43, C44, C47-C60	22	0.1 μ F, 25V 10% ceramic capacitors (1206)	Panasonic	ECJ-3VB1E104K
C13, C15-C17, C20, C22, C23, C25, C26, C37, C38	11	10 μ F, 10V, 20% ceramic capacitors (1206)	Panasonic	ECJ-3YB1A106M
C27-C36, C39-C42	14	0.1 μ F, 16V 10% ceramic capacitors (0805)	Phycomp	08052R104K7B20D
C45, C46	2	22pF, 100V 10% ceramic capacitors (1206)	AVX	12061A220KAT2A
C18, C19	2	68 μ F, 16V 20% tantalum capacitors (D case)	Panasonic	ECS-T1CD686R
C3-C6, C9-C12	8	47,000pF, 0V 10% ceramic capacitors (1206)	Panasonic	ECU-V1H473KBW
D1	1	1A, 50V diode	Generic	1N4001
DS1-DS3, DS5, DS6, DS9, DS10, DS13, DS14, DS18	10	LED, red, SMD	Panasonic	LN1251C
DS4, DS7, DS8, DS11, DS12, DS16, DS19, DS20	8	LED, green, SMD	Panasonic	LN1351C
J1	1	Connector, 10-pin, dual row, vertical	Digi-Key (Distributor)	S2012-05-ND
J2-J9	8	Right angle BNC	Amphenol	31-5431
J10	1	Connector, DB9 RA, short case	Amp	788750-2
J11	1	Terminal strip, 50-pin, dual row vertical	Samtec	TSW-125-07-T-D
J12, J14	2	Socket, banana plug, horizontal, red	Mouser	164-6219
J13	1	Socket, banana plug, horizontal, black	Mouser	164-6218
JMP1-JMP10	10	Do not place, open 3-pin TH jumper	N/A	N/A
JMP11-JMR14	4	Do not place, shorted 2-pin TH jumper	N/A	N/A
L1	1	22.0 μ H, 2-pin SMT 20% inductor	Coiltronics	UP1B-220
R7-R12, R14, R31, R32, R34-R36, R38, R77, R78, R83-R90, R96-R98	26	332 Ω 1% 1/10W resistors (0805)	Panasonic	ERJ-6ENF3320V
R48-R52, R60-R76	22	33.2 Ω 1% 1/10W resistors (0805)	Panasonic	ERJ-6ENF33R2V
R17, R41, R42, R46, R55, R56, R92	7	0 Ω 5% 1/10W resistors (0805)	Panasonic	ERJ-6GEY0R00V
R1-R6, R13, R15, R16, R18, R19, R22, R24-R30, R40, R43, R53, R54, R79-R82, R91, R95	29	10k Ω 5%, 1/10W resistors (0805)	Panasonic	ERJ-6GEYJ103V
R93	1	3.9 Ω 5%, 1/10W resistors (0805)	Panasonic	ERJ-6GEYJ3R9V
R20, R21, R23, R33, R37, R39, R44, R45, R47, R57-R59	12	Resistors (0805), do not populate	N/A	N/A
SW1-SW4	4	Switch, SPDT slide, 3-pin TH	Tyco	SSA12
SW5, SW6	2	Switch MOM 4-pin single pole	Panasonic	EVQPAE04M
T1-T8	8	XFMR, XMIT/RCV, 1 to 2CT, SMT 6-pin	Pulse Engineering	PE-65968
Y1	1	Oscillator, crystal clock, 3.3V, 44.736MHz	Saronix	NTH089AA3-44.736
Y2	1	Oscillator, crystal clock, 3.3V, 34.368MHz	Saronix	NTH089AA3-34.368
Y3	1	11.0592MHz low-profile crystal	Pletronics	LP49-33-11.0592M

BOARD FLOORPLAN

Figure 1 shows the floorplan of the DS3154DK. The DS3154 is near the center of the board, surrounded by 2:1 transformers. The line-side BNC connectors for the transmit (Tx) and receive (Rx) differential pairs are located at the bottom of the board. LEDs driven by DS3154 pins \overline{RLOS}_n , \overline{TDM}_n , and \overline{PRBS}_n are located next to the corresponding BNC connectors. An LED driven by the DS3154's \overline{INT} pin is located to the far right. The system connector in the upper-left corner presents all of the DS3154's framer interface pins: \overline{RCLK}_n , $\overline{RPOS}_n/\overline{RDAT}_n$, $\overline{RNEG}/\overline{RLCV}_n$, \overline{TCLK}_n , $\overline{TPOS}_n/\overline{TDAT}_n$, and \overline{TNEG}_n . In the upper-right corner are banana jacks for ground, board V_{DD} , and a separate DS3154 V_{DD} (useful for DS3154 I_{DD} measurements). The board also contains DS3 and E3 oscillators and the necessary jumpers to configure the DS3154 transmitters for clocking from the oscillators, from the system connector or from the DS3154 receivers (external remote loopback). In the right-center of the board are a DS87C520 microcontroller and associated components, including four switches and four LEDs connected to the controller's general-purpose I/O pins. The microcontroller translates memory access requests from the RS-232 serial port (top-center of the board) into register accesses on the DS3154.

Figure 1. Board Floorplan

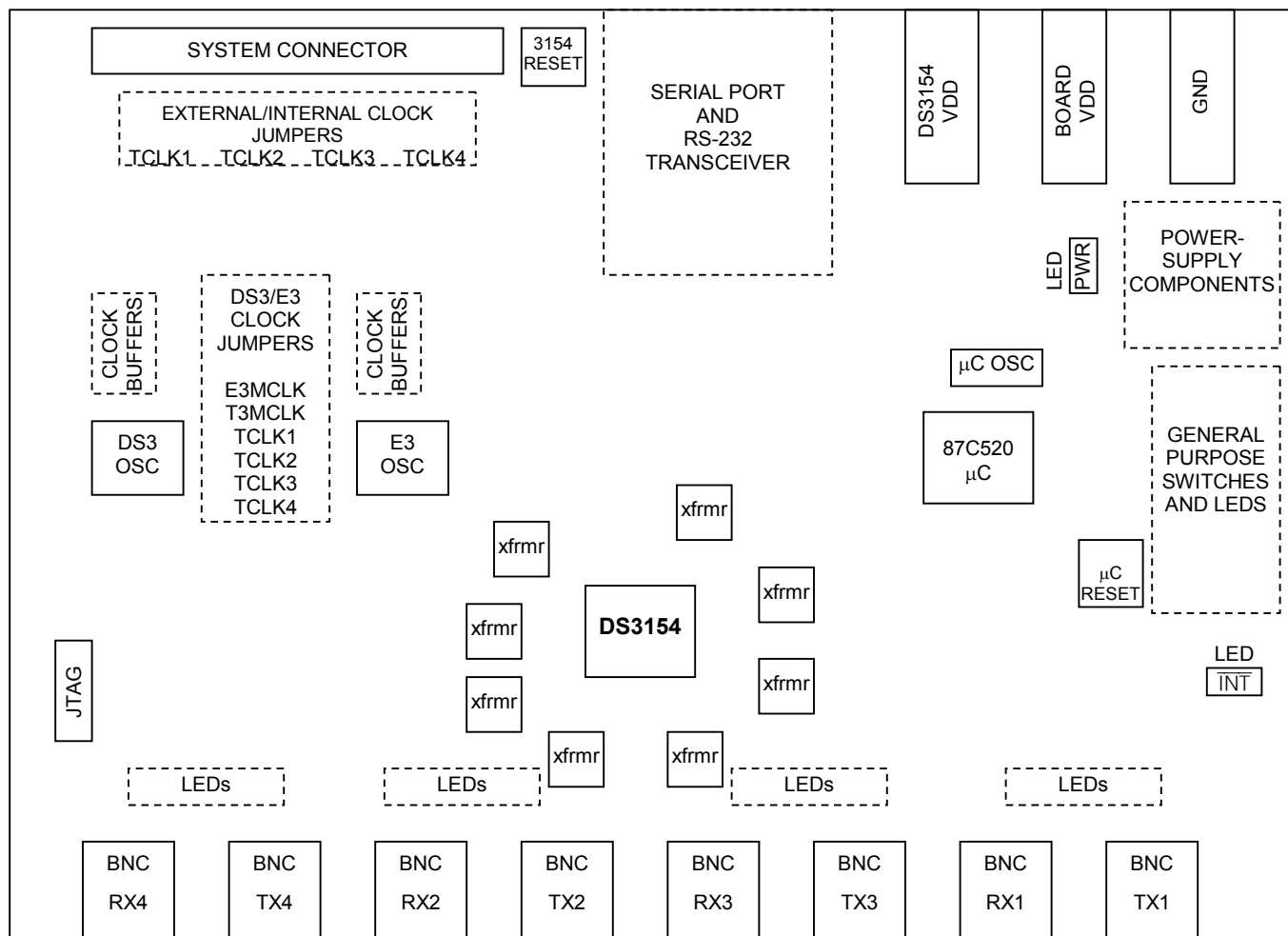

TCLK JUMPERS

Jumpers JMP7, JMP8, JMP9, and JMP10 (just below the system connector) select the clock source for the DS3154 transmitters. The center pin on each of these jumpers is connected directly to the associated TCLK pin on the DS3154. To drive a DS3154 TCLK pin from the system connector, connect the center pin and the EXT (external) pin of the associated jumper. To drive a DS3154 TCLK pin from one of the on-board oscillators, connect the center pin and the INT (internal) pin of the associated jumper. Jumpers JMP2, JMP3, JMP4, and JMP5 select between the DS3 oscillator and the E3 oscillator ([Figure 2](#)).

Figure 2. TCLK Jumpers

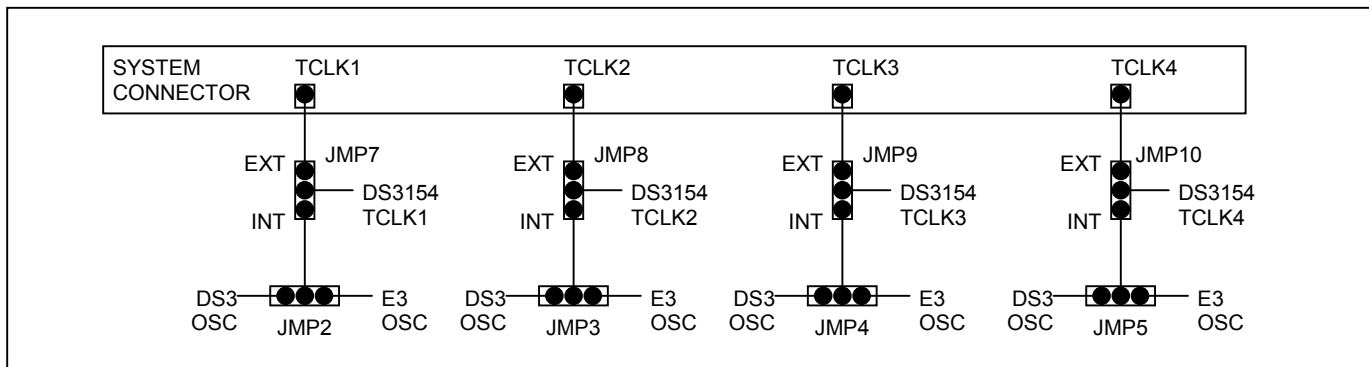

LINE-SIDE CONNECTIONS

The DS3154DK implements the transmit (Tx) and receive (Rx) line interface networks recommended in the DS3154 data sheet and shown in [Figure 3](#). The BNC connectors for LIU1 are labeled TX1 and RX1. The BNC connectors for LIU2 are labeled TX2 and RX2. The BNC connectors for LIU3 are labeled TX3 and RX3. The BNC connectors for LIU4 are labeled TX4 and RX4.

Figure 3. Line-Side Circuitry

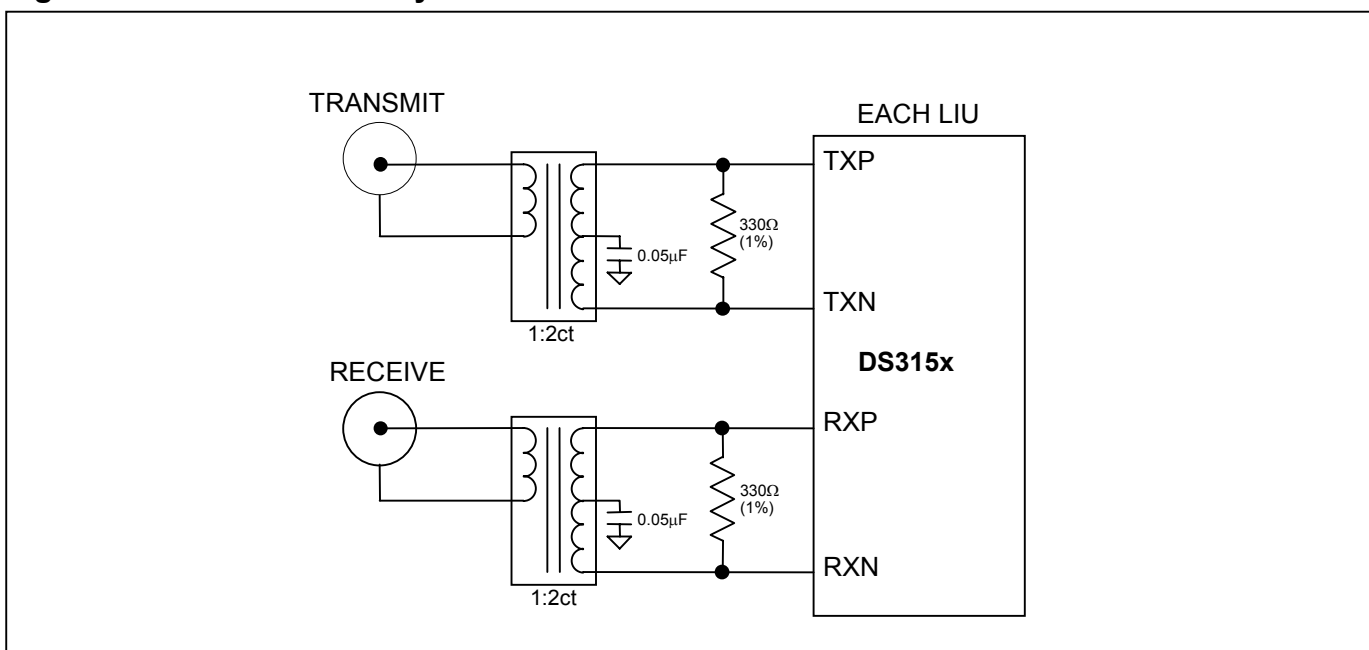

SYSTEM CONNECTOR

The 50-pin system connector at the top of the board gives access to the following DS3154 signals: STMCLK, RCLKn, RPOSn/RDATn, RNEG/RLCVn, TCLKn, TPOSn/TDATn, and TNEGn. The system connector can be used to connect the DS3154 to an external DS3/E3 framer or other data source/sink. By using jumpers to connect TCLKn to RCLKn, TPOSn to RPOSn, and TNEGn to RNEGn, the system connector can also be used to implement an external remote loopback. In addition, it can be used to wire DS3154 input pins like TPOSn and TNEGn low. To wire a pin low, use a jumper to connect it to the neighboring GND pin on the upper row of the system connector.

MICROCONTROLLER, SWITCHES, AND LEDS

The DS87C520 microcontroller has factory-installed firmware in on-chip nonvolatile memory. This firmware translates memory access requests from the RS-232 serial port into register accesses on the DS3154. Switches SW1 through SW4 and LEDs DS7, DS11, DS19, and DS20 are connected to four general-purpose I/O pins on the microcontroller. When the microcontroller starts up it turns on DS20 and leaves DS7, DS11, and DS19 off to indicate that the controller is working correctly. Otherwise, these switches and LEDs are not used by the DS3154DK firmware.

POWER-SUPPLY CONNECTORS

Connect a 3.3V power supply across the red J12 (DK V_{DD}) and black J13 (GND) banana jacks. Connect a separate supply to the red J14 (3154 V_{DD}) and black J13 (GND). Jumpers (JMP11–JMP14) are provided to measure the device's current and can be used instead of J14. The supplies (V_{DD} and $V3_3$) have been separated from what is shown in the schematic (page 4, Section D-3) because switching power-supply noise is affecting generated jitter on the DS3154. The supplies should not be wired together for any jitter performance measurements.

CONNECTING TO A COMPUTER

Connect a standard DB-9 serial cable between the serial port on the DS3154DK and an available serial port on the host computer. The host computer must be a Windows[®]-based PC. Be sure the cable is a standard straight-through cable rather than a null-modem cable. Null-modem cables prevent proper operation.

INSTALLING AND RUNNING THE SOFTWARE

ChipView is a general-purpose program that supports a number of Dallas Semiconductor demo kits. To install the ChipView software, run SETUP.EXE from the disk included in the DS3154DK box or from the zip file downloadable on our website at www.maxim-ic.com/DS3154DK.

After installation, run the ChipView program with the DS3154DK board powered up and connected to the PC. If the default installation options were used, one easy way to run ChipView is to click the Start button on the Windows toolbar and select Programs→ChipView→ChipView. In the opening screen, click the Register View button. (The Demo and Terminal buttons are not supported for the DS3154DK.) Select the correct serial port in the Port Selection dialog box, then click OK.

Next, the Definition File Assignment window appears. This window has subwindows to select definition files for up to four separate boards on other Dallas evaluation platforms. Because ChipView is communicating with the DS3154DK, only one subwindow is active. In the active subwindow, select the DS3154.DEF definition file from the list shown, or browse to find it in another directory. Press the Continue button.

After selecting the definition file, the main part of the ChipView window displays the DS3154's register map. The registers in LIU1 are displayed in the left column followed by registers for the other LIUs in subsequent columns. To select a register, click on it in the register map. When a register is selected, the full name of the register and its bit map are displayed at the bottom of the ChipView window. Bits that are logic 0 are displayed in white, while bits that are logic 1 are displayed in green.

The ChipView software supports the following actions:

- **Toggle a bit.** Select the register in the register map and then click the bit in the bit map.
- **Write a register.** Select the register, click the Write button, and enter the value to be written.
- **Write all registers.** Click the Write All button and enter the value to be written.
- **Read a register.** Select the register in the register map and click the Read button.
- **Read all registers.** Click the Read All button.

BASIC DS3154DK CONFIGURATION

These example configurations provide a quick start to using the DS3154DK. The DS3154 and the DS3154DK can be configured in many other ways. To set up other configurations, refer to the DS3154 data sheet and other sections of this data sheet.

DS3 Configuration

- 1) On the system connector, jumper all four TPOS pins and all four TNEG pins to ground.
- 2) On jumpers JMP7 through JMP10, connect the center post to the INT post. This connects the DS3154's TCLK1 through TCLK4 pins to an on-board oscillator.
- 3) Place jumpers JMP2 through JMP5 to connect the DS3154's TCLK1 through TCLK4 pins to the on-board DS3 oscillator. Make sure JMP1 has T3MCLK connected to the DS3 oscillator. Make sure JMP6 has E3MCLK connected to the E3 oscillator.
- 4) Press and release the DS3154 reset button on the DK board –OR– set and then clear the RST bit in each GCR register. The reset default mode is DS3.
- 5) Clear the TTS bit in each TCR register and clear the RTS bit in each RCR register.
- 6) Set the TDSA and TDSB bits in each GCR register to transmit a $2^{15} - 1$ PRBS pattern.
- 7) For each LIU port, connect the transmitter to the receiver using 75Ω coax to configure an external local loopback –OR– set the LLB bit in each GCR register to configure an internal local loopback.
- 8) Press the Read All button twice to update the display.

At this point the transmitter is generating a $2^{15} - 1$ PRBS pattern that is being looped back to the receiver. On the DS3154DK board, the PRBS LEDs should be lit, indicating PRBS sync. The $\overline{\text{TDM}}$ and $\overline{\text{RLOS}}$ LEDs should not be lit. In the register map, the SR and SRL registers should contain all zeros.

E3 Configuration

- 1) On the system connector, jumper all four TPOS pins and all four TNEG pins to ground.
- 2) On jumpers JMP7 through JMP10, connect the center post to the INT post. This connects the DS3154's TCLK1 through TCLK4 pins to an on-board oscillator.
- 3) Place jumpers JMP2 through JMP5 to connect the DS3154's TCLK1 through TCLK4 pins to the on-board E3 oscillator. Make sure JMP6 has E3MCLK connected to the E3 oscillator. Make sure JMP1 has T3MCLK connected to the DS3 oscillator.
- 4) Press and release the DS3154 reset button on the DK board –OR– set and then clear the RST bit in each GCR register.
- 5) Set the E3 bit in each GCR register.
- 6) Clear the TTS bit in each TCR register and clear the RTS bit in each RCR register.
- 7) Set the TDSA and TDSB bits in each GCR register to transmit a $2^{23} - 1$ PRBS pattern.
- 8) For each LIU port, connect the transmitter to the receiver using 75Ω coax to configure an external local loopback –OR– set the LLB bit in each GCR register to configure an internal local loopback.
- 9) Press the Read All button twice to update the display.

At this point the transmitter is generating a $2^{23} - 1$ PRBS pattern that is being looped back to the receiver. On the DS3154DK board, the PRBS LEDs should be lit, indicating PRBS sync. The $\overline{\text{TDM}}$ and $\overline{\text{RLOS}}$ LEDs should not be lit. In the register map, the SR and SRL registers should contain all zeros.

STS-1 Configuration

- 1) On the system connector, jumper all four TPOS pins and all four TNEG pins to ground.
- 2) On jumpers JMP7 through JMP10, connect the center post to the EXT post. This connects the DS3154's TCLK1 through TCLK4 pins to the respective pins on the system connector. (The position of jumpers JMP1 through JMP6 does not matter.)
- 3) Apply an STS-1 clock source (51.84MHz) to the STMCLK, TCLK1, TCLK2, TCLK3, and TCLK4 pins on the system connector.
- 4) Press and release the DS3154 reset button on the DK board –OR– set and then clear the RST bit in each GCR register.
- 5) Set the E3 and STS bits in each GCR register to configure each LIU for STS-1 operation.
- 6) Clear the TTS bit in each TCR register and clear the RTS bit in each RCR register.
- 7) Set the TDSA and TDSB bits in each GCR register to transmit a $2^{15} - 1$ PRBS pattern.
- 8) For each LIU port, connect the transmitter to the receiver using 75Ω coax to configure an external local loopback –OR– set the LLB bit in each GCR register to configure an internal local loopback.
- 9) Press the Read All button twice to update the display.

At this point the transmitter is generating a $2^{15} - 1$ PRBS pattern that is being looped back to the receiver. On the DS3154DK board, the PRBS LEDs should be lit, indicating PRBS sync. The $\overline{\text{TDM}}$ and $\overline{\text{RLOS}}$ LEDs should not be lit. In the register map, the SR and SRL registers should contain all zeros.

DS3154 INFORMATION

The DS3154 Quick View page on our website has the latest DS3154 data sheet, application notes, and downloads. Go to www.maxim-ic.com/DS3154.

DS3154DK INFORMATION

The DS3154DK Quick View page on our website has the latest DS3154DK data sheet, ChipView software updates, and downloads. Go to www.maxim-ic.com/DS3154DK.

TECHNICAL SUPPORT

For additional technical support, please email your questions to telecom.support@dalsemi.com.

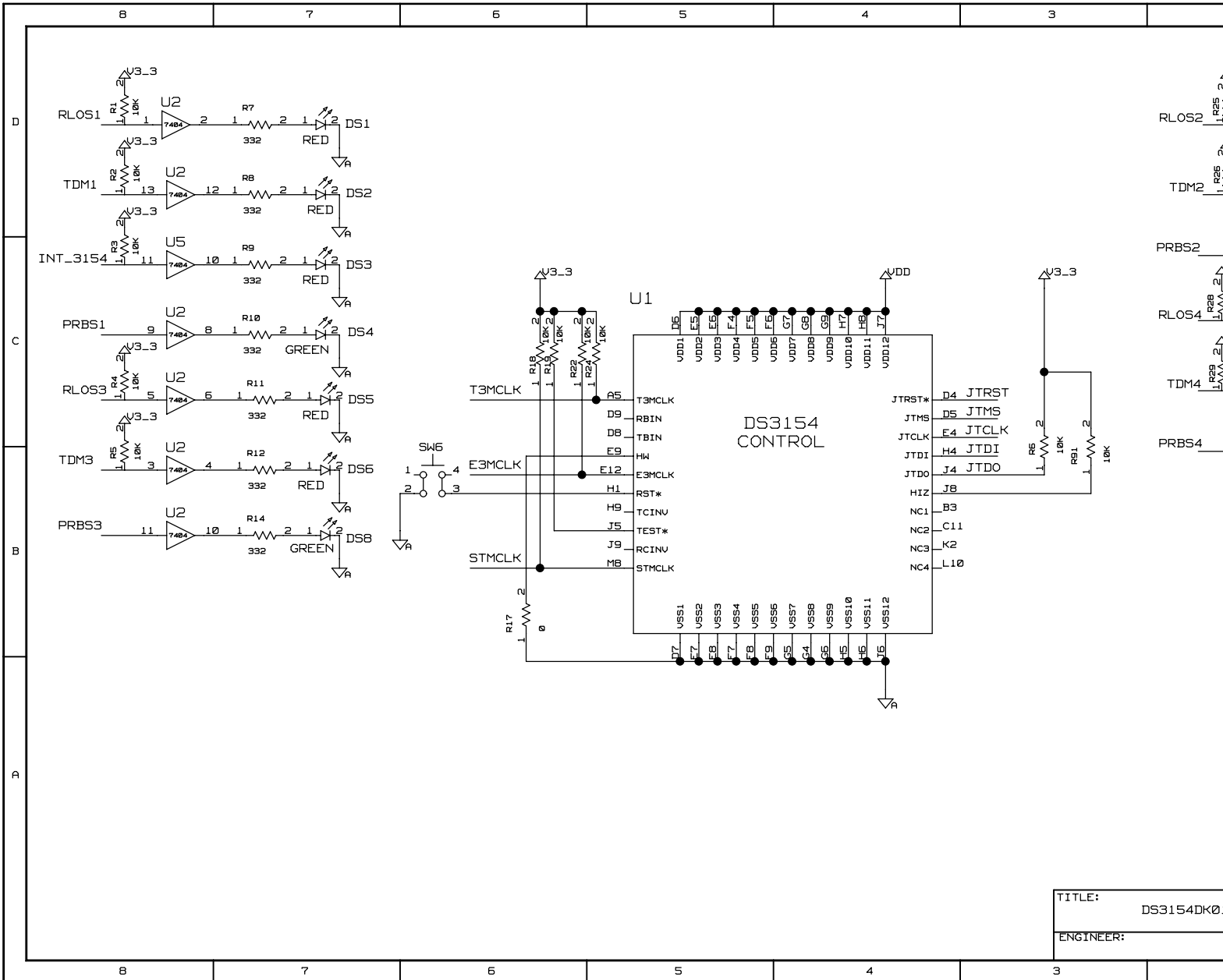

TITLE: DS3154DK0
 ENGINEER:

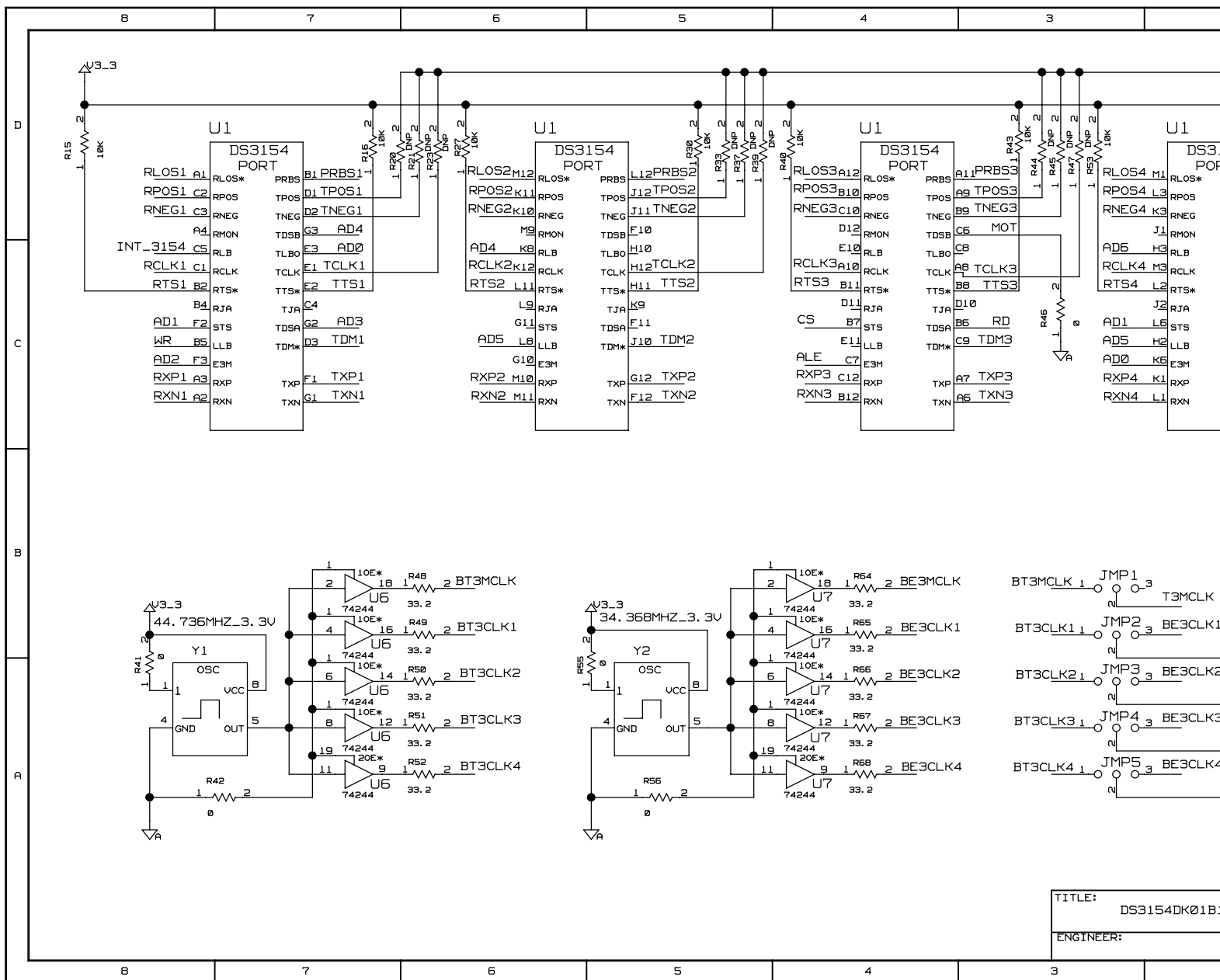

TITLE: DS3154DK01B
 ENGINEER:

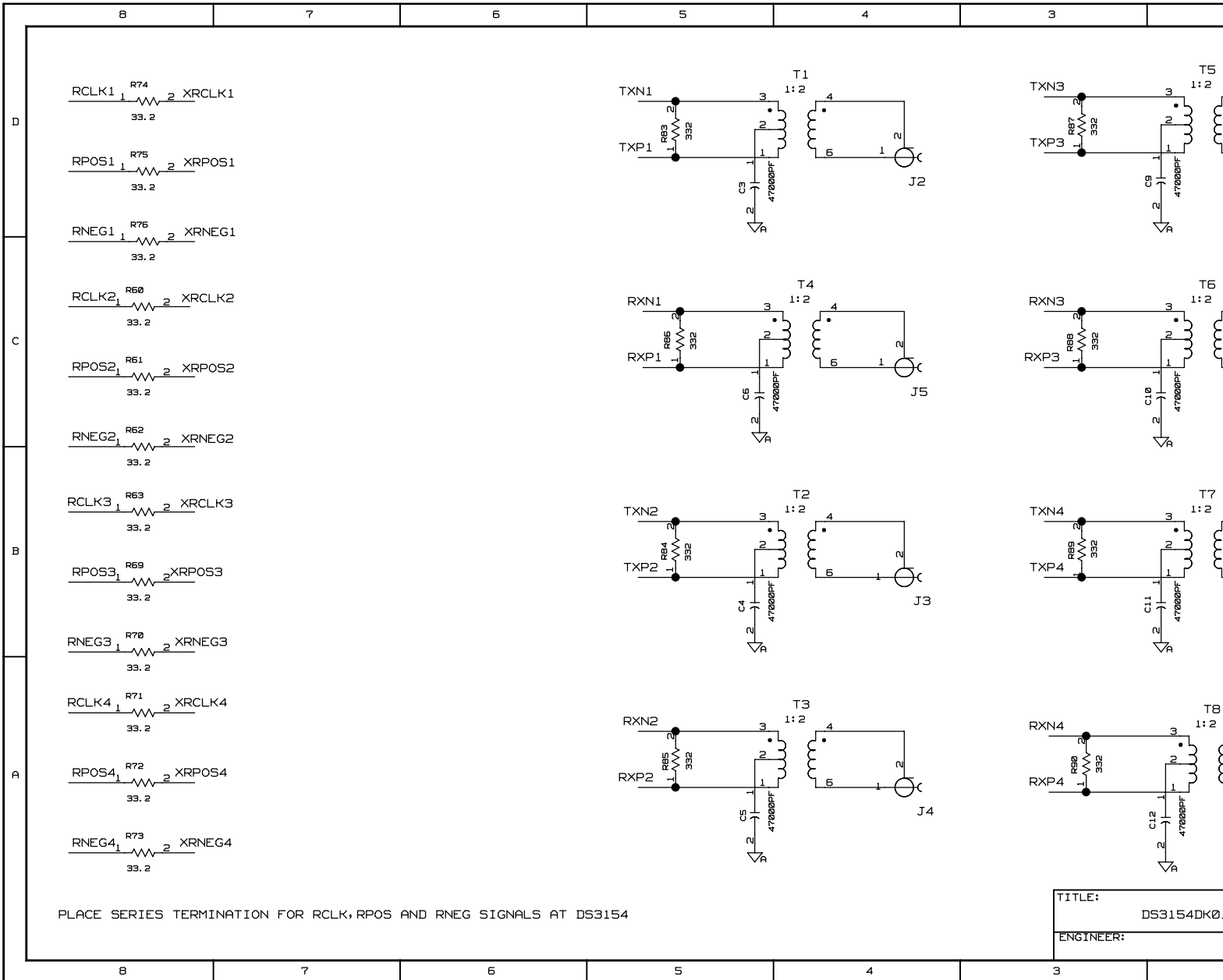

RCLK1 ^{R74} 33.2 XRCLK1
 RPOS1 ^{R75} 33.2 XRPOS1
 RNEG1 ^{R76} 33.2 XRNEG1
 RCLK2 ^{R60} 33.2 XRCLK2
 RPOS2 ^{R61} 33.2 XRPOS2
 RNEG2 ^{R62} 33.2 XRNEG2
 RCLK3 ^{R63} 33.2 XRCLK3
 RPOS3 ^{R69} 33.2 XRPOS3
 RNEG3 ^{R70} 33.2 XRNEG3
 RCLK4 ^{R71} 33.2 XRCLK4
 RPOS4 ^{R72} 33.2 XRPOS4
 RNEG4 ^{R73} 33.2 XRNEG4

PLACE SERIES TERMINATION FOR RCLK, RPOS AND RNEG SIGNALS AT DS3154

TITLE: DS3154DK0
 ENGINEER:

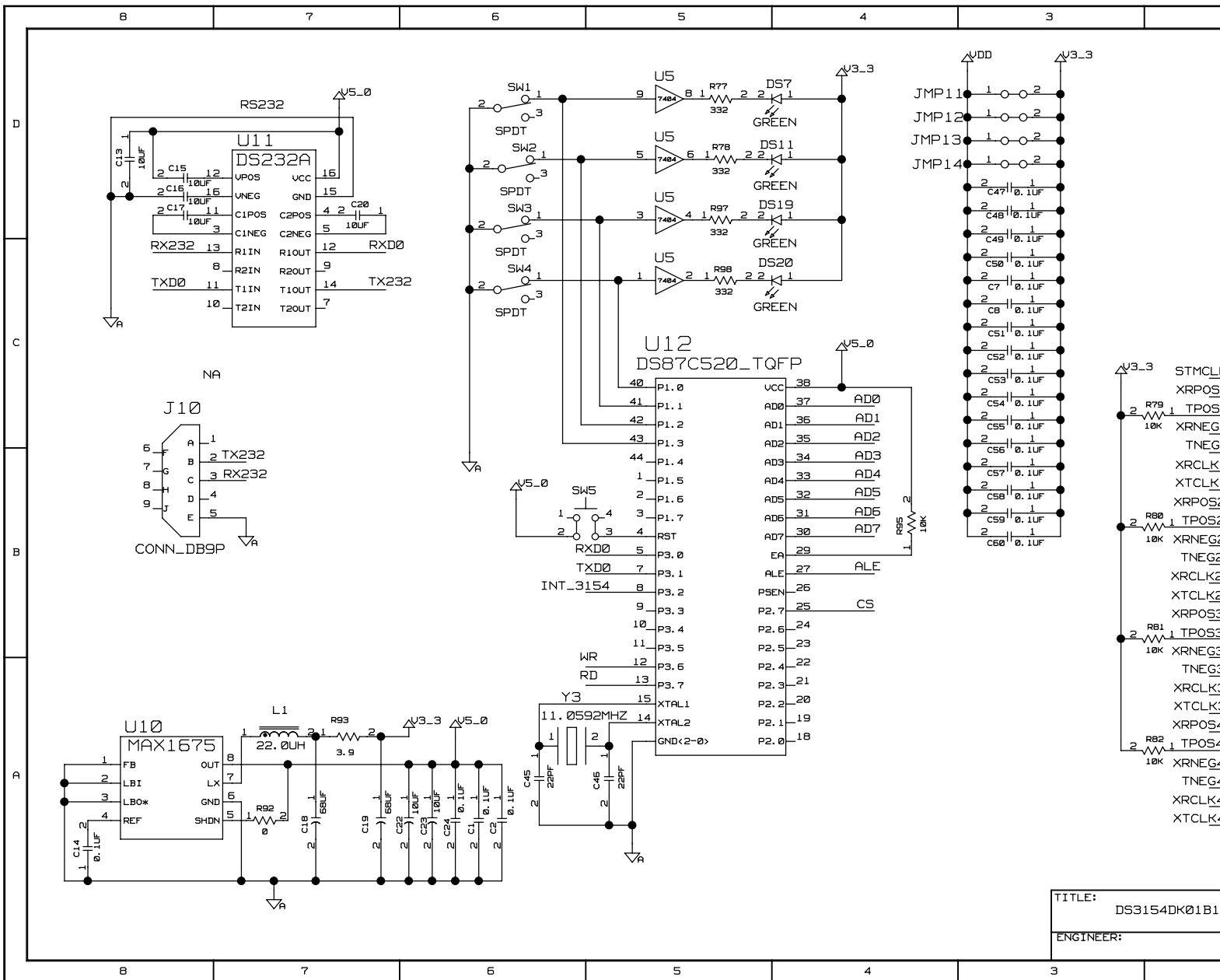

TITLE: DS3154DK01B1
 ENGINEER: