



February 1997

## DS34LV86T 3V Enhanced CMOS Quad Differential Line Receiver

### General Description

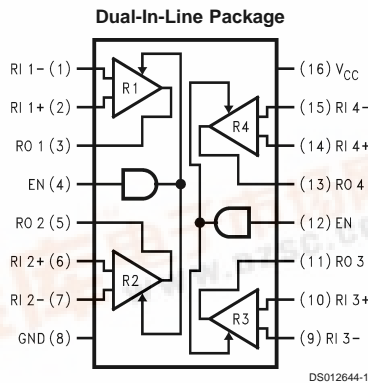
The DS34LV86T is a high speed quad differential CMOS receiver that meets the requirements of both TIA/EIA-422-B and ITU-T V.11. The CMOS DS34LV86T features typical low static  $I_{CC}$  of 9 mA which makes it ideal for battery powered and power conscious applications. The TRI-STATE® enables, EN, allow the device to be disabled when not in use to minimize power consumption. The dual enable scheme allows for flexibility in turning receivers on and off.

The receiver output (RO) is guaranteed to be High when the inputs are left open. The receiver can detect signals as low as  $\pm 200$  mV over the common mode range of  $\pm 10$ V. The receiver outputs (RO) are compatible with TTL and LVCMOS levels.

### Features

- Low power CMOS design (30 mW typical)
- Interoperable with existing 5V RS-422 networks
- Industrial temperature range
- Meets TIA/EIA-422-B (RS-422) and ITU-T V.11 recommendation
- 3.3V Operation
- $\pm 7$ V common mode range  $V_{ID} = 3$ V
- $\pm 10$ V common mode range  $V_{ID} = 0.2$ V
- Receiver OPEN input failsafe feature
- Guaranteed AC parameter:  
Maximum Receiver Skew: 4 ns  
Transition time: 10 ns
- Pin compatible with DS34C86T
- 32 MHz Toggle Frequency
- 6.5k ESD Tolerance (HBM)
- Available in SOIC packaging

### Connection Diagram



Top View  
Order Number DS34LV86TN, DS34LV86TM  
See NS Package Number M16A or N16E

### Truth Table

Enable EN	Inputs RI+–RI–	Output RO
L	X	Z
H	$V_{ID} \geq +0.2$ V	H
H	$V_{ID} \leq -0.2$ V	L
H	Open†	H

L = Logic Low  
H = Logic High  
X = Irrelevant  
Z = TRI-STATE  
† = Open, Not Terminated

TRI-STATE® is a registered trademark of National Semiconductor Corporation.



## Absolute Maximum Ratings (Note 1)

If Military/Aerospace specified devices are required, please contact the National Semiconductor Sales Office/Distributors for availability and specifications.

Supply Voltage ( $V_{CC}$ )	+7V
Enable Input Voltage (EN)	+7V
Receiver Input Voltage ( $V_{ID}$ : RI+, RI-)	±14V
Receiver Input Voltage ( $V_{CM}$ : RI+, RI-)	±14V
Receiver Output Voltage (RO)	-0.5V to $V_{CC} + 0.5V$
Receiver Output Current (RO)	±25 mA
Maximum Package Power Dissipation +25°C	
M Package	1190 mW
N Package	1645 mW
Derate M Package	9.8 mW/°C above +25°C

Derate N Package	13.9 mW/°C above +25°C
Storage Temperature Range	65°C to +150°C
Lead Temperature Range	
Soldering (4 Seconds)	+260°C
ESD Ratings (HBM, 1.5k, 100 pF)	
Receiver Inputs and Enables	≥6.5 kV
Other Pins	≥2 kV

## Recommended Operating Conditions

	Min	Typ	Max	Units
Supply Voltage ( $V_{CC}$ )	3.0	3.3	3.6	V
Operating Free Air Temperature ( $T_A$ )	-40	+25	+85	°C

## Electrical Characteristics (Notes 2, 3)

Over Supply Voltage and Operating Temperature ranges, unless otherwise specified.

Symbol	Parameter	Conditions	Pin	Min	Typ	Max	Units
$V_{TH}$	Differential Input Threshold	$V_{OUT} = V_{OH}$ or $V_{OL}$ $-7V < V_{CM} < +7V$	RI+, RI-	-200	±17.5	+200	mV
$V_{HY}$	Hysteresis	$V_{CM} = 1.5V$			35		mV
$V_{IH}$	Minimum High Level Input Voltage		EN	2.0			V
$V_{IL}$	Minimum Low Level Input Voltage					0.8	V
$R_{IN}$	Input Resistance	$V_{IN} = -7V, +7V$ (Other Input = GND)		5.0	8.5		kΩ
$I_{IN}$	Input Current (Other Input = 0V, Power On or $V_{CC} = 0V$ )	$V_{IN} = +10V$	RI+, RI-	0	1.1	1.8	mA
		$V_{IN} = +3V$		0	0.27		mA
		$V_{IN} = 0.5V$			-0.02		mA
		$V_{IN} = -3V$		0	-0.43		mA
		$V_{IN} = -10V$		0	-1.26	-2.2	mA
$I_{EN}$		$V_{IN} = 0V$ to $V_{CC}$	EN			±1	μA
$V_{OH}$	High Level Output Voltage	$I_{OH} = -6$ mA, $V_{ID} = +1V$ $I_{OH} = -6$ mA, $V_{ID} = OPEN$		2.4	3		V
$V_{OH}$	High Level Output Voltage	$I_{OH} = -100$ μA, $V_{ID} = +1V$ $I_{OH} = -100$ μA, $V_{ID} = OPEN$			$V_{CC} - 0.1$		V
$V_{OL}$	Low Level Output Voltage	$I_{OL} = +6$ mA, $V_{ID} = -1V$	RO		0.13	0.5	V
$I_{OZ}$	Output TRI-STATE Leakage Current	$V_{IN} = V_{CC}$ or GND $EN = V_{IL}$				±50	μA
$I_{SC}$	Output Short Circuit Current	$V_O = 0V$ , $V_{ID} \geq  200$ mV  (Note 4)		-10	-35	-70	mA
$I_{CC}$	Power Supply Current	No Load, All RI+, RI- = Open, $EN = V_{CC}$ or GND	$V_{CC}$		9	15	mA

## Switching Characteristics (Notes 3, 9, 10)

Over Supply Voltage and Operating Temperature ranges, unless otherwise specified.

Symbol	Parameter	Conditions	Min	Typ	Max	Units
$t_{PHL}$	Propagation Delay High to Low	$C_L = 15 \text{ pF}$ (Figures 1, 2)	6	17.5	35	ns
$t_{PLH}$	Propagation Delay Low to High		6	17.8	35	ns
$t_r$	Rise Time (20% to 80%)			4.1	10	ns
$t_f$	Fall Time (80% to 20%)			3.3	10	ns
$t_{PHZ}$	Disable Time	$C_L = 50 \text{ pF}$ (Figures 3, 4)			40	ns
$t_{PLZ}$	Disable Time				40	ns
$t_{PZH}$	Enable Time				40	ns
$t_{PZL}$	Enable Time				40	ns
$t_{SK1}$	Skew, $ t_{PHL} - t_{PLH} $ (Note 5)	$C_L = 15 \text{ pF}$		0.3	4	ns
$t_{SK2}$	Skew, Pin to Pin (Note 6)			0.6	4	ns
$t_{SK3}$	Skew, Part to Part (Note 7)			7	17	ns
$f_{MAX}$	Maximum Operating Frequency (Note 8)	$C_L = 15 \text{ pF}$	32			MHz

**Note 1:** "Absolute Maximum Ratings" are those values beyond which the safety of the device cannot be guaranteed. They are not meant to imply that the devices should be operated at these limits. The table of "Electrical Characteristics" specifies conditions of device operation.

**Note 2:** Current into device pins is defined as positive. Current out of device pins is defined as negative. All voltages are referenced to ground except  $V_{ID}$ .

**Note 3:** All typicals are given for:  $V_{CC} = +3.3\text{V}$ ,  $T_A = +25^\circ\text{C}$ .

**Note 4:** Short one output at a time to ground. Do not exceed package power dissipation ratings.

**Note 5:**  $t_{SK1}$  is the  $|t_{PHL} - t_{PLH}|$  of a channel.

**Note 6:**  $t_{SK2}$  is the maximum skew between any two channels within a device, on either edge.

**Note 7:**  $t_{SK3}$  is the difference in propagation delay times between any channels of any devices. This specification (maximum limit) applies to devices within  $V_{CC} \pm 0.1\text{V}$  of one another, and a  $\Delta T_A = \pm 5^\circ\text{C}$  (between devices) within the operating temperature range. This parameter is guaranteed by design and characterization.

**Note 8:** All channels switching, output duty cycle criteria is 40%/60% measured at 50% Input = 1V to 2V, 50% Duty Cycle,  $t_r/t_f \leq 5 \text{ ns}$ . This parameter is guaranteed by design and characterization.

## Parameter Measurement Information

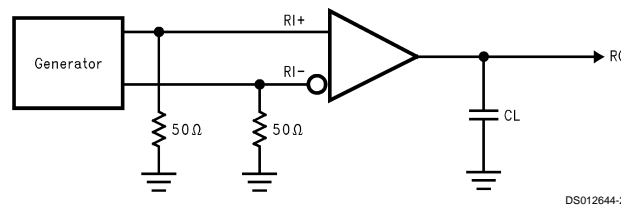


FIGURE 1. Receiver Propagation Delay and Transition Time Test Circuit (Notes 9, 10)

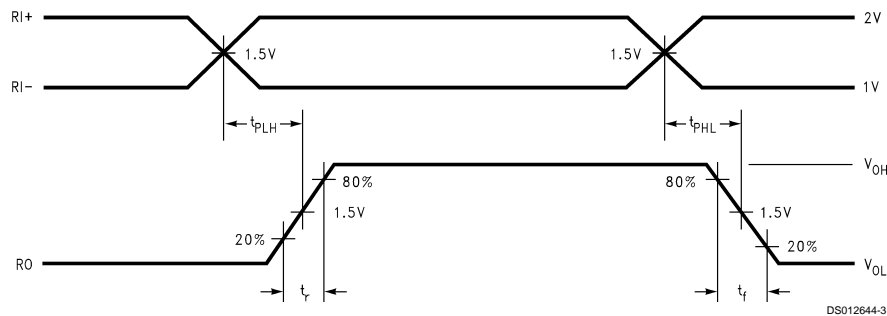


FIGURE 2. Receiver Propagation Delay and Transition Time Waveform (Notes 9, 10)

**Note 9:** Generator waveform for all tests unless otherwise specified:  $f = 1 \text{ MHz}$ , Duty Cycle = 50%,  $Z_O = 50\Omega$ ,  $t_r \leq 10 \text{ ns}$ ,  $t_f \leq 10 \text{ ns}$ .

**Note 10:**  $C_L$  includes probe and jig capacitance.

## Parameter Measurement Information (Continued)

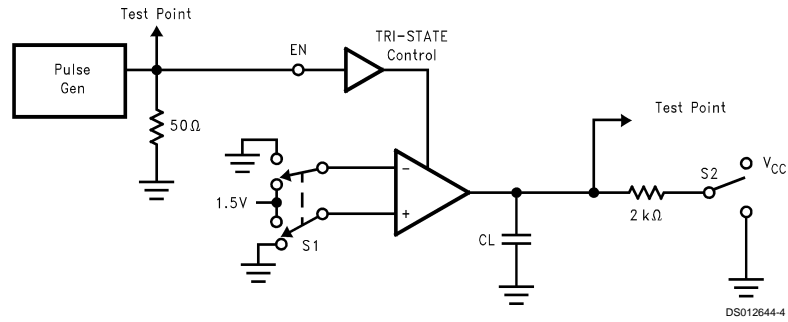


FIGURE 3. Receiver TRI-STATE Test Circuit

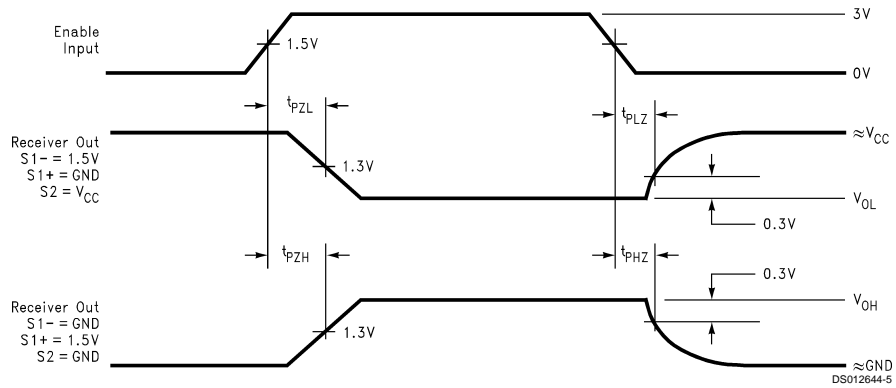


FIGURE 4. Receiver TRI-STATE Output Enable and Disable Waveforms (Notes 9, 10)

## Typical Application Information

General application guidelines and hints for differential drivers receivers may be found in the following application notes:

AN-214, AN-457, AN-805, AN-847, AN-903, AN-912, AN-916

**Power Decoupling Recommendations:** Bypass caps must be used on power pins. High frequency ceramic (surface mount is recommended) 0.1  $\mu\text{F}$  in parallel with 0.01  $\mu\text{F}$  at the power supply pin. A 10  $\mu\text{F}$  or greater solid tantalum or electrolytic should be connected at the power entry point on the printed circuit board.

## Typical Application Information (Continued)

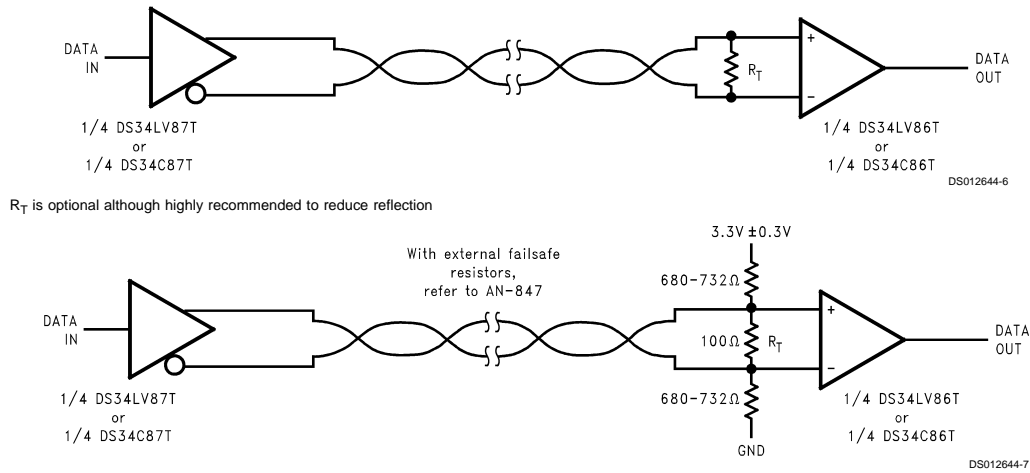


FIGURE 5. Typical Receiver Connections

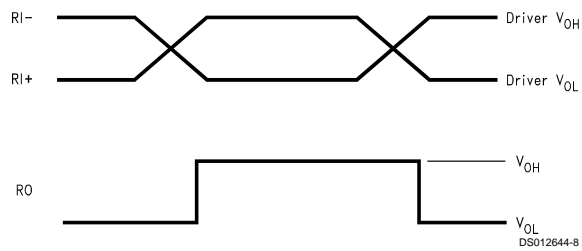


FIGURE 6. Typical Receiver Output Waveforms

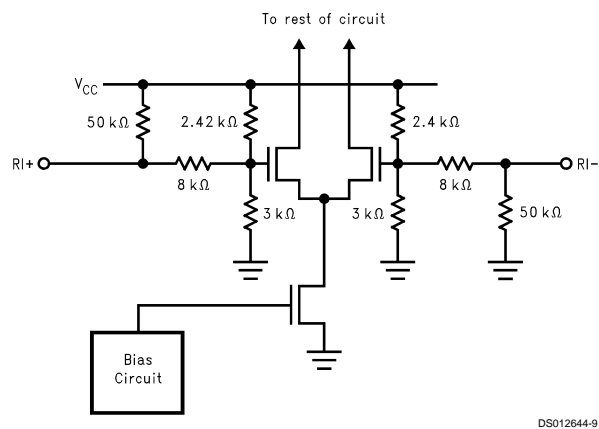
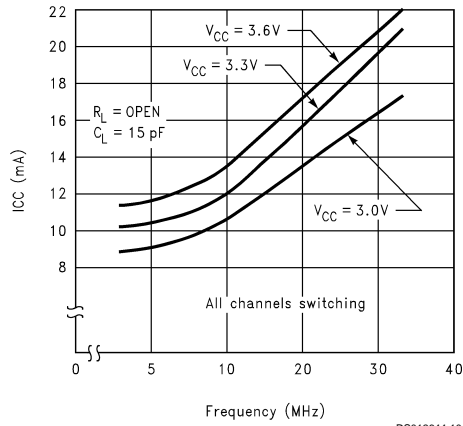
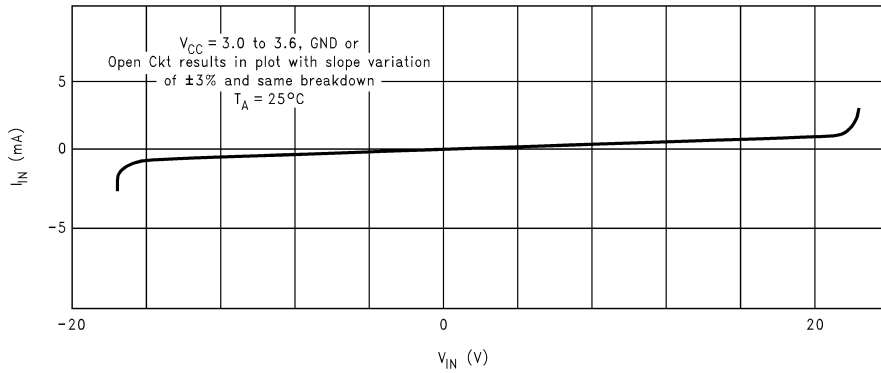


FIGURE 7. Typical Receiver Input Circuit

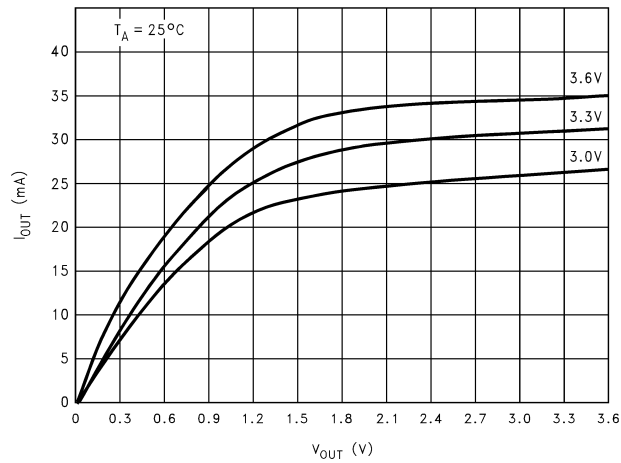
**Typical Application Information** (Continued)



**FIGURE 8. Typical  $I_{CC}$  vs Frequency**

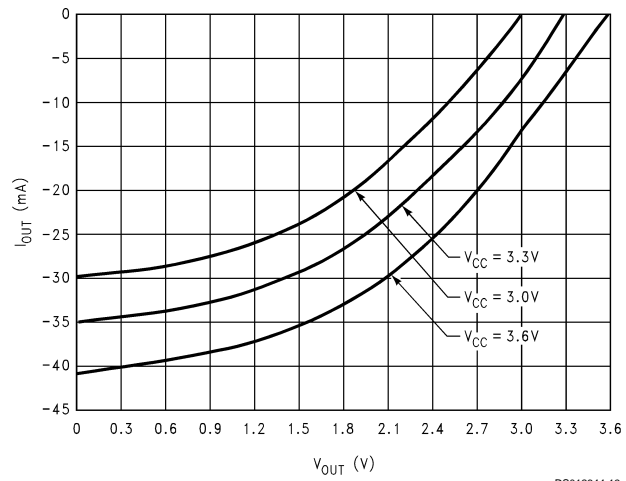


**FIGURE 9.  $I_{IN}$  vs  $V_{IN}$  (Power On, Power Off)**



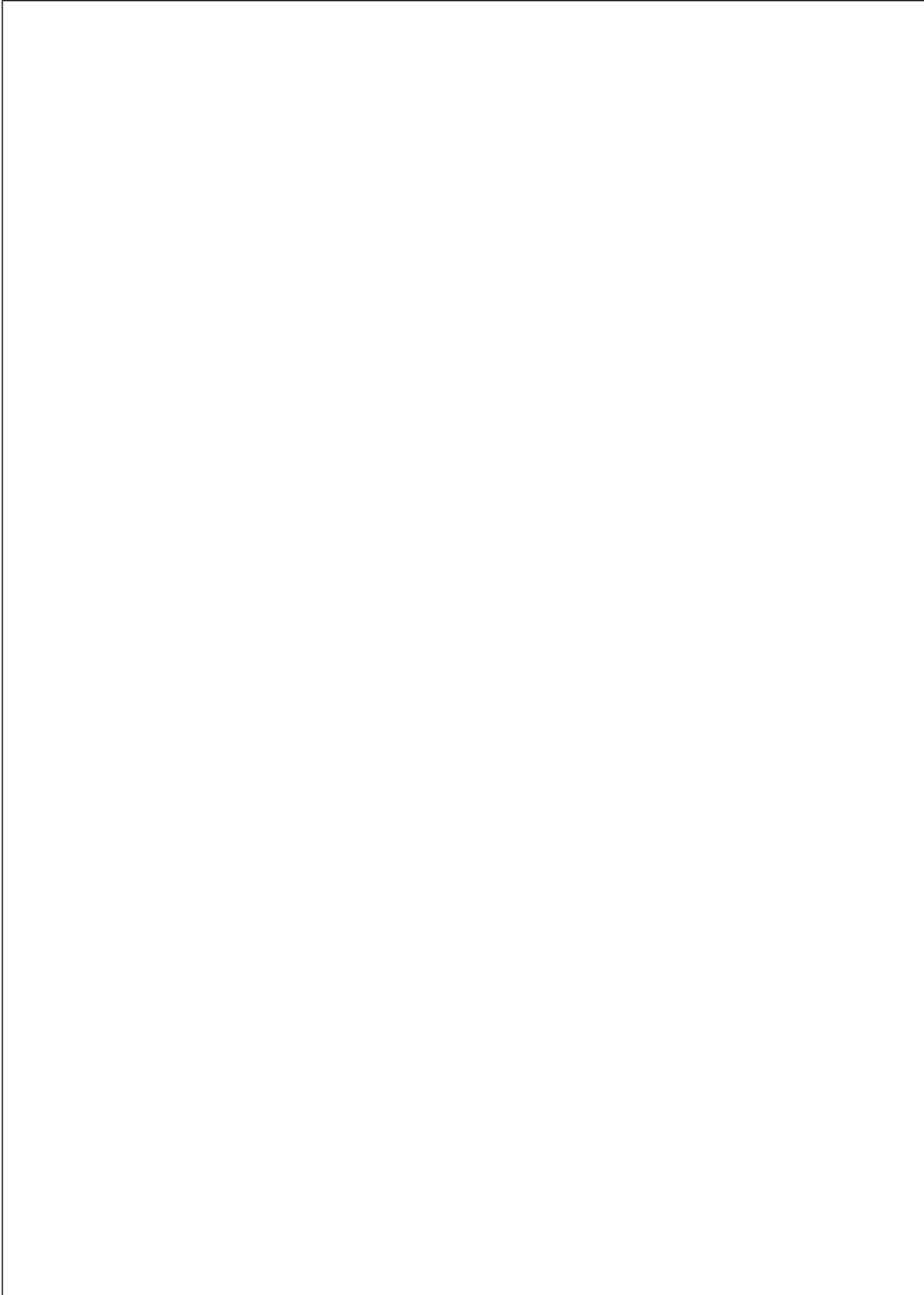
**FIGURE 10.  $I_{OL}$  vs  $V_{OL}$**

**Typical Application Information** (Continued)



**FIGURE 11.  $I_{OH}$  vs  $V_{OH}$**

DS012644-13





**LIFE SUPPORT POLICY**

NATIONAL'S PRODUCTS ARE NOT AUTHORIZED FOR USE AS CRITICAL COMPONENTS IN LIFE SUPPORT DEVICES OR SYSTEMS WITHOUT THE EXPRESS WRITTEN APPROVAL OF THE PRESIDENT OF NATIONAL SEMICONDUCTOR CORPORATION. As used herein:

1. Life support devices or systems are devices or systems which, (a) are intended for surgical implant into the body, or (b) support or sustain life, and whose failure to perform when properly used in accordance with instructions for use provided in the labeling, can be reasonably expected to result in a significant injury to the user.
2. A critical component in any component of a life support device or system whose failure to perform can be reasonably expected to cause the failure of the life support device or system, or to affect its safety or effectiveness.



**National Semiconductor Corporation**  
Americas  
Tel: 1-800-272-9959  
Fax: 1-800-737-7018  
Email: support@nsc.com

[www.national.com](http://www.national.com)

**National Semiconductor Europe**  
Fax: +49 (0) 1 80-530 85 86  
Email: europe.support@nsc.com  
Deutsch Tel: +49 (0) 1 80-530 85 85  
English Tel: +49 (0) 1 80-532 78 32  
Français Tel: +49 (0) 1 80-532 93 58  
Italiano Tel: +49 (0) 1 80-534 16 80

**National Semiconductor Asia Pacific Customer Response Group**  
Tel: 65-2544466  
Fax: 65-2504466  
Email: sea.support@nsc.com

**National Semiconductor Japan Ltd.**  
Tel: 81-3-5620-6175  
Fax: 81-3-5620-6179