

RF MOSFET Power Transistor, 80W, 28V

2 - 175 MHz

DU2880T

V2.00

Features

- N-Channel Enhancement Mode Device
- DMOS Structure
- Lower Capacitances for Broadband Operation
- High Saturated Output Power
- Lower Noise Figure Than Competitive Devices

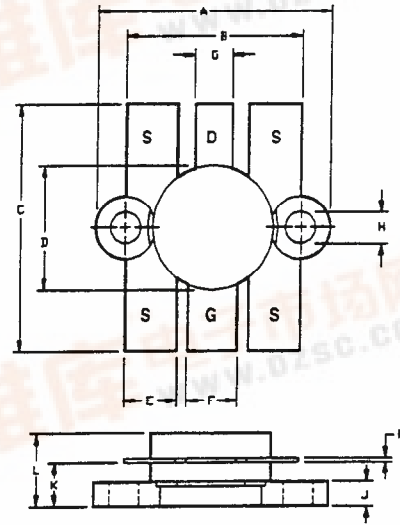

Absolute Maximum Ratings at 25°C

Parameter	Symbol	Rating	Units
Drain-Source Voltage	V_{DS}	65	V
Gate-Source Voltage	V_{GS}	20	V
Drain-Source Current	I_{DS}	16	A
Power Dissipation	P_D	206	W
Junction Temperature	T_J	200	°C
Storage Temperature	T_{STG}	-65 to +150	°C
Thermal Resistance	θ_{JC}	0.85	°C/W

LETTER DIM	MILLIMETERS		INCHES	
	MIN	MAX	MIN	MAX
A	24.38	25.15	.960	.990
B	18.29	18.54	.720	.730
C	21.36	21.74	.841	.856
D	12.60	12.85	.496	.506
E	5.33	5.59	.210	.220
F	5.08	5.33	.200	.210
G	3.81	4.06	.150	.160
H	3.10	3.15	.122	.128
J	2.51	2.67	.099	.105
K	4.06	4.57	.160	.180
L	6.68	7.49	.263	.295
M	.10	.15	.004	.006

Electrical Characteristics at 25°C

Parameter	Symbol	Min	Max	Units	Test Conditions
Drain-Source Breakdown Voltage	BV_{DSS}	65	-	V	$V_{GS}=0.0\text{ V}$, $I_{DS}=20.0\text{ mA}$
Drain-Source Leakage Current	I_{DSS}	-	4.0	mA	$V_{DS}=28.0\text{ V}$, $V_{GS}=0.0\text{ V}$
Gate-Source Leakage Current	I_{GSS}	-	4.0	μA	$V_{GS}=20.0\text{ V}$, $V_{DS}=0.0\text{ V}$
Gate Threshold Voltage	$V_{GS(TH)}$	2.0	6.0	V	$V_{DS}=10.0\text{ V}$, $I_{DS}=400.0\text{ mA}$
Forward Transconductance	G_M	2.0	-	S	$V_{DS}=10.0\text{ V}$, $I_{DS}=4.0\text{ A}$, $\Delta V_{GS}=1.0\text{ V}$, 80 μs Pulse
Input Capacitance	C_{ISS}	-	180	pF	$V_{DS}=28.0\text{ V}$, $F=1.0\text{ MHz}$
Output Capacitance	C_{OSS}	-	160	pF	$V_{DS}=28.0\text{ V}$, $F=1.0\text{ MHz}$
Reverse Capacitance	C_{RSS}	-	32	pF	$V_{DS}=28.0\text{ V}$, $F=1.0\text{ MHz}$
Power Gain	G_P	13	-	dB	$V_{DD}=28.0\text{ V}$, $I_{DQ}=400\text{ mA}$, $P_{OUT}=80.0\text{ W}$, $F=175\text{ MHz}$
Drain Efficiency	η_D	60	-	%	$V_{DD}=28.0\text{ V}$, $I_{DQ}=400\text{ mA}$, $P_{OUT}=80.0\text{ W}$, $F=175\text{ MHz}$
Load Mismatch Tolerance	VSWR-T	-	30:1	-	$V_{DD}=28.0\text{ V}$, $I_{DQ}=400\text{ mA}$, $P_{OUT}=80.0\text{ W}$, $F=175\text{ MHz}$

Specifications Subject to Change Without Notice.

M/A-COM, Inc.

North America: Tel. (800) 366-2266

Asia/Pacific: Tel. +81 (03) 3226-1671

Europe: Tel. +44 (1344) 869 595

Typical Broadband Performance Curves

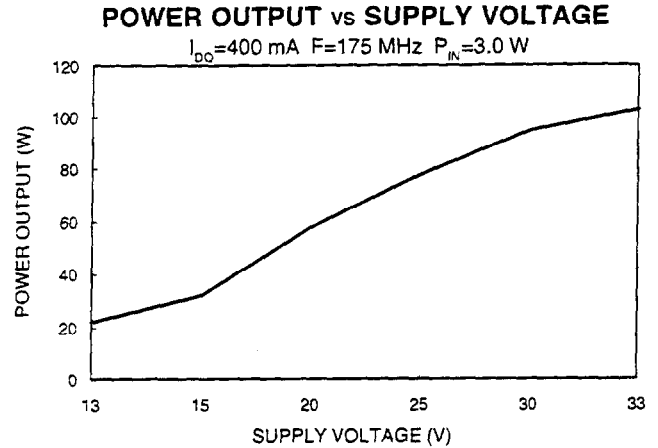
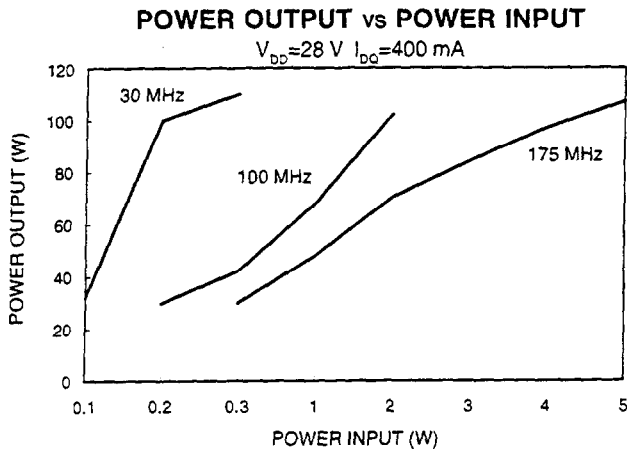
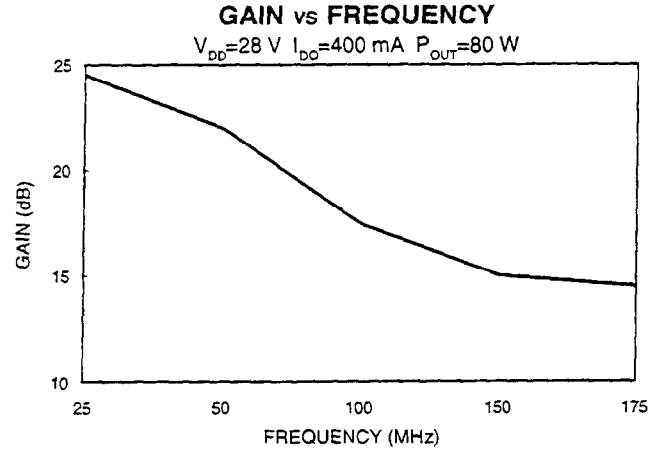
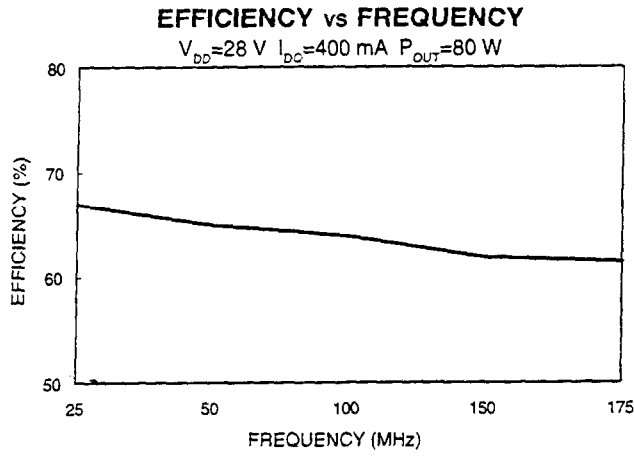

Specifications Subject to Change Without Notice.

M/A-COM, Inc.

North America: Tel. (800) 366-2266
 Fax (800) 618-8883

Asia/Pacific: Tel. +81 (03) 3226-1671
 Fax +81 (03) 3226-1451

Europe: Tel. +44 (1344) 869 595
 Fax +44 (1344) 300 020

Typical Device Impedance

Frequency (MHz)	Z _{IN} (OHMS)	Z _{LOAD} (OHMS)
30	5.4 - j 4.4	5.7 + j 4.7
50	2.5 - j 4.4	3.4 + j 3.5
100	1.6 - j 3.4	2.4 + j 2.4
175	0.7 - j 1.2	1.7 + j 0.8

V_{DD}=28 V, I_{DO}=400 mA, P_{OUT}=80 Watts

Z_{IN} is the series equivalent input impedance of the device from gate to source.

Z_{LOAD} is the optimum series equivalent load impedance as measured from drain to ground.

RF Test Fixture

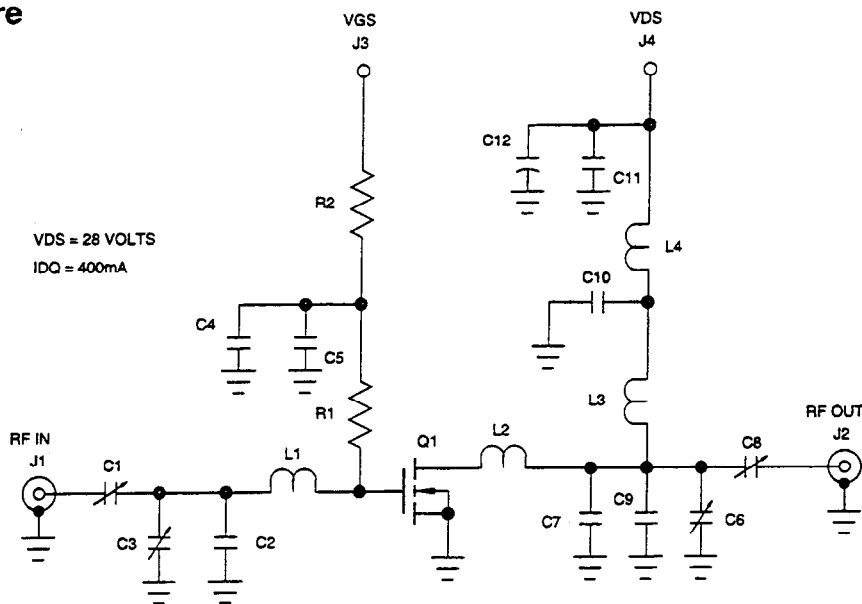

PARTS LIST

C1,C3	TRIMMER CAPACITOR 4-40pF
C2,C9,C10	CAPACITOR 50pF
C4,C11	CAPACITOR 1000pF
C5	MONOLITHIC CIRCUIT CAPACITOR 0.01uF
C6,C8	TRIMMER CAPACITOR 9-180pF
C7	CAPACITOR 15pF
C12	ELECTROLYTIC CAPACITOR 50uF 50 VOLT
L1	NO. 12 AWG COPPER WIRE X 1.18" (LOOP 0.5")
L2	NO. 12 AWG COPPER WIRE X 1" (LOOP 0.4")
L3,L4	8 TURNS OF NO. 18 AWG ENAMEL WIRE ON Ø.25", CLOSE WOUND
R1	RESISTOR 300 OHMS 0.5 WATT
R2	RESISTOR 2.7K OHMS 0.25 WATT
Q1	DU2880T
BOARD	FR4 0.062"

Specifications Subject to Change Without Notice.

M/A-COM, Inc.