

3 Phase Bridge Modules EH80, EH100

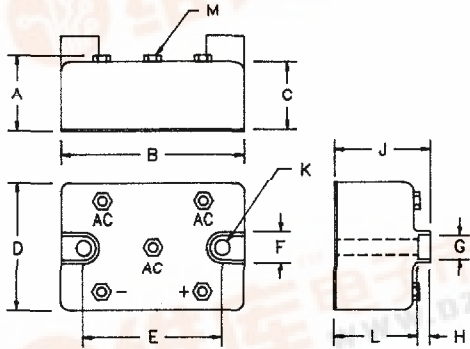

Dim.	Inches		Millimeter		Notes
	Minimum	Maximum	Minimum	Maximum	
A	—	1.10	—	27.94	
B	2.25	2.40	57.15	60.96	
C	.930	.950	23.62	24.13	
D	1.740	1.760	44.19	44.70	
E	1.883	1.887	47.82	47.92	
F	.495	.505	12.57	12.83	
G	.325	.335	8.25	8.50	
H	.215	.225	5.46	5.71	
J	1.270	1.300	32.25	33.02	
K	.198	.208	5.02	5.28	Dia.
L	1.055	1.075	26.79	27.30	
M	#10-32 Tapped Holes				

Microsemi Catalog Number	Repetitive Peak Reverse Voltage	
EH8002ZI*	EH10002ZI*	200
EH8004ZI*	EH10004ZI*	400
EH8006ZI*	EH10006ZI*	600
EH8008ZI*	EH10008ZI*	800
EH8010ZI*	EH10010ZI*	1000
EH8012ZI*	EH10012ZI*	1200

*Add S for Transient Suppressor across output

- Integral Transient Suppression Available
- High Terminal-to-base Isolation of 2500VAC RMS
- Available to 1200V
- Mounting Bolts Isolated From Power Terminals

Electrical Characteristics			
	EH80	EH100	
Maximum DC output current, 3-phase	Io 80A	100A	Sine wave, 120° conduction
Maximum case temperature	Tc 138°C	141°C	
Maximum surge current per diode	IFSM 1050A	1500A	8.3ms, half sine, Tj = 175°C
Max. I ² t for fusing	I ² t 4600A ² S	9300A ² S	
Max. peak forward voltage per diode	VFM 1.2V	1.1V	① Io; Tj = 25°C
Max. peak reverse voltage per diode	IRM 4mA		VRRM, Tj = 150°C
Minimum isolation voltage	VSOL 2500VRMS		any terminal-to-base

Thermal and Mechanical Characteristics		
Storage temp range	TSTG	-40°C to 175°C
Operating junction temp range	Tj	-40°C to 175°C
Max thermal resistance per diode	EH80 RθJC	1.0°C/W Junction to case
	EH100 RθJC	0.85°C/W Junction to case
Max mounting torque		30 lb-in
Typical thermal resistance	RθCS	0.07°C/W Case to sink
Typical Weight		5.8 ounces (165 grams)

Microsemi Corp.
Colorado

PH: 303-469-2161
FAX: 303-466-3775

E-69



EH80, EH100

Figure 1
Typical Forward Characteristics - Per Diode

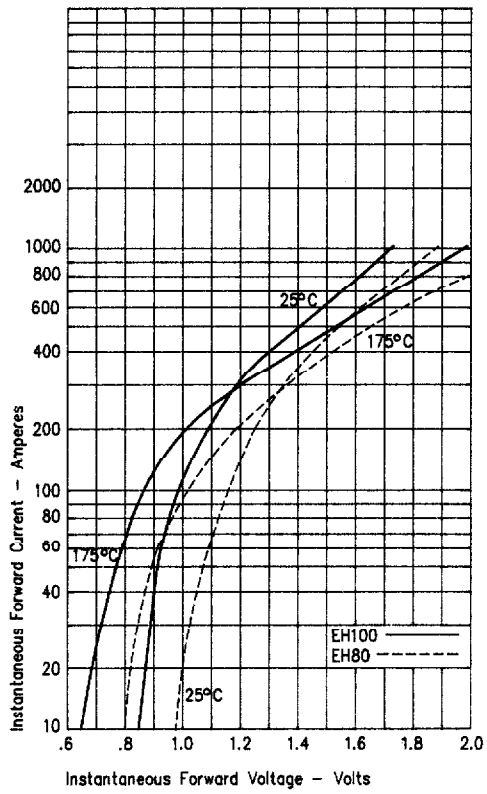

Figure 3
Maximum Nonrepetitive Surge Current - Per Diode

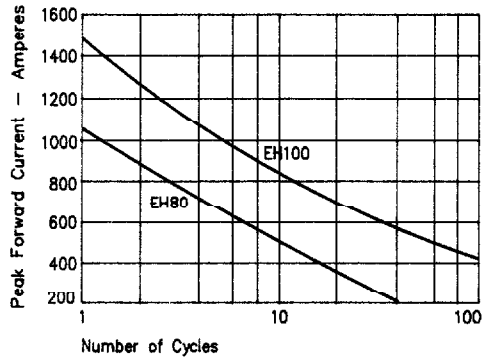

Figure 2
Forward Current Derating - Per Diode

