

MAXIM

256-Tap SOT-PoT, Low-Drift Digital Potentiometers in SOT23

MAX5400/MAX5401

General Description

The MAX5400/MAX5401 digital potentiometers offer 256-tap SOT-PoT™ digitally controlled variable resistors in tiny 8-pin SOT23 packages. Each device functions as a mechanical potentiometer, consisting of a fixed resistor string with a digitally controlled wiper contact. They operate from +2.7V to +5.5V single-supply voltages and use an ultra-low supply current of 0.1µA. These devices also provide glitchless switching between resistor taps, as well as a convenient power-on reset that sets the wiper to the midscale position at power-up. A low 5ppm/°C ratiometric temperature coefficient makes it ideal for applications requiring low drift.

The MAX5400/MAX5401 serve well in applications requiring digitally controlled resistors, including adjustable voltage references and programmable gain amplifiers (PGAs). A nominal end-to-end resistor temperature coefficient of 50ppm/°C allows these parts to be used as variable resistors in applications such as low-tempco adjustable gain and other circuit configurations.

Two resistance values are available: 50kΩ (MAX5400) and 100kΩ (MAX5401). Each device is guaranteed over the extended industrial temperature range (-40°C to +85°C).

Applications

- Mechanical Potentiometer Replacement
- Low-Drift PGAs
- Adjustable Voltage References

Features

- ◆ Miniature 8-Pin SOT23 (3mm x 3mm)
- ◆ 256 Tap Positions
- ◆ Ultra-Low 0.1µA Supply Current
- ◆ Single-Supply Operation: +2.7V to +5.5V
- ◆ Low Ratiometric Temperature Coefficient: 5ppm/°C
- ◆ Power-On Reset: Wiper Goes to Midscale (Position 128)
- ◆ Glitchless Switching Between the Resistor Taps
- ◆ 3-Wire SPI™-Interface Compatible
- ◆ 50kΩ/100kΩ Resistor Values

Ordering Information

PART	TEMP. RANGE	PIN-PACKAGE	R (kΩ)
MAX5400EKA-T	-40°C to +85°C	8-SOT23	50
MAX5401EKA-T	-40°C to +85°C	8-SOT23	100

SOT-PoT is a trademark of Maxim Integrated Products.
SPI is a trademark of Motorola, Inc.

Pin Configuration appears at end of data sheet.

Functional Diagram

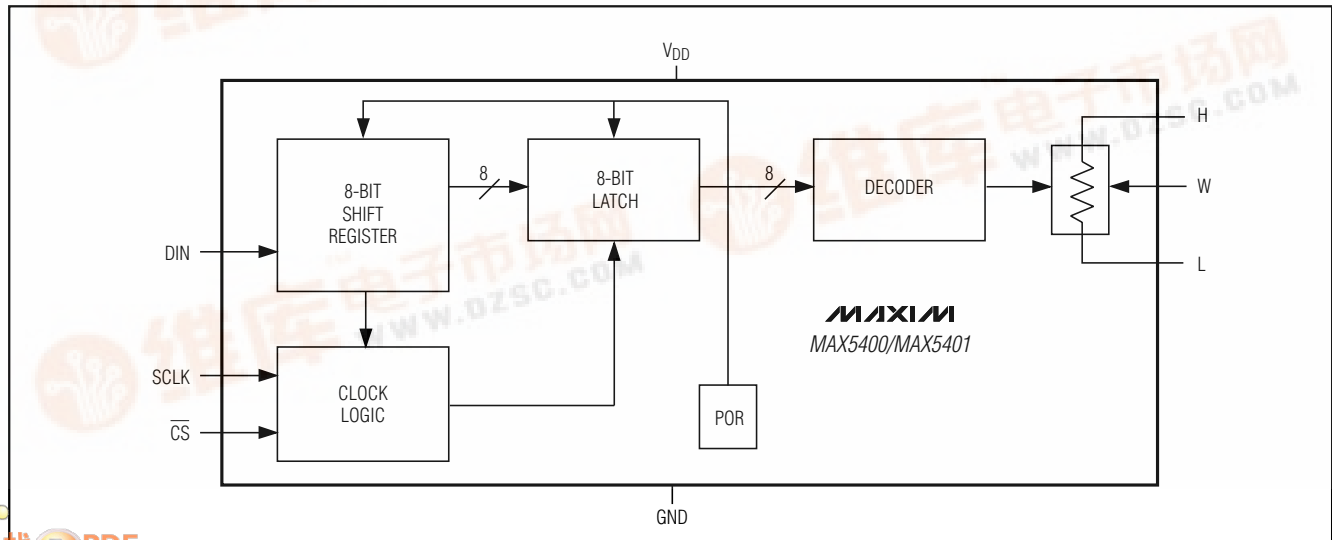

256-Tap SOT-PoT, Low-Drift Digital Potentiometers in SOT23

ABSOLUTE MAXIMUM RATINGS

V _{DD} to GND	-0.3V to +6V
DIN, SCLK, CS to GND	-0.3V to +6V
H, L, W to GND	-0.3V to (V _{DD} + 0.3V)
Maximum Continuous Current into Pins H, L, and W	±1mA

Continuous Power Dissipation (T _A = +70°C) 8-Pin SOT23 (derate 8.7mW/°C above +70°C)	697mW
Operating Temperature Range	-40°C to +85°C
Junction Temperature	+150°C
Storage Temperature Range	-65°C to +150°C
Lead Temperature (soldering, 10s)	+300°C

Stresses beyond those listed under "Absolute Maximum Ratings" may cause permanent damage to the device. These are stress ratings only, and functional operation of the device at these or any other conditions beyond those indicated in the operational sections of the specifications is not implied. Exposure to absolute maximum rating conditions for extended periods may affect device reliability.

ELECTRICAL CHARACTERISTICS

(V_{DD} = +5V, V_H = V_{DD}, V_L = 0, T_A = T_{MIN} to T_{MAX}. Typical values are at T_A = +25°C, unless otherwise noted. Parameters are measured at T_A = +25°C. Values over full temperature range are guaranteed by design.)

PARAMETER	SYMBOL	CONDITIONS	MIN	TYP	MAX	UNITS
DC PERFORMANCE (Voltage Divider Mode)						
Resolution	N		8			Bits
Integral Nonlinearity (Notes 1, 2)	INL				±1/2	LSB
Differential Nonlinearity (Notes 1, 2)	DNL				±1/2	LSB
End-to-End Resistor Tempco	TC _R			50		ppm/°C
Ratiometric Resistor Tempco				5		ppm/°C
Full-Scale Ratio Error		MAX5400		-0.8		LSB
		MAX5401		-0.4		
Zero-Scale Ratio Error		MAX5400		+0.8		LSB
		MAX5401		+0.4		
POWER SUPPLIES						
Supply Voltage	V _{DD}		2.7		5.5	V
Supply Current	I _{DD}	CS = SCLK = DIN = V _{DD}	V _{DD} = 5V	0.7	5	μA
			V _{DD} = 2.7V	0.1		μA
DC PERFORMANCE (Variable Resistor Mode)						
Resolution	N		8			Bits
Integral Nonlinearity (Notes 1, 3)	INL	V _{CC} = 5V			±1	LSB
		V _{CC} = 3V	MAX5400		±1.5	
			MAX5401		±1	
Differential Nonlinearity (Notes 1, 3)	DNL	V _{CC} = 5V			±1/2	LSB
		V _{CC} = 3V			±1/2	
DC PERFORMANCE (Resistor Characteristics)						
Wiper Resistance (Note 4)	R _W			250	800	Ω
Wiper Capacitance	C _W			25		pF
End-to-End Resistance	R _{HL}	MAX5401	75	100	125	kΩ
		MAX5400	37.5	50	62.5	

256-Tap SOT-PoT, Low-Drift Digital Potentiometers in SOT23

MAX5400/MAX5401

ELECTRICAL CHARACTERISTICS (continued)

($V_{DD} = +5V$, $V_H = V_{DD}$, $V_L = 0$, $T_A = T_{MIN}$ to T_{MAX} . Typical values are at $T_A = +25^\circ C$, unless otherwise noted. Parameters are measured at $T_A = +25^\circ C$. Values over full temperature range are guaranteed by design.)

PARAMETER	SYMBOL	CONDITIONS	MIN	TYP	MAX	UNITS
DIGITAL INPUTS						
Input High Voltage	V_{IH}	$V_{CC} = 5V$	$0.7 \times V_{DD}$			V
Input Low Voltage	V_{IL}	$V_{CC} = 5V$		$0.3 \times V_{DD}$		V
Input High Voltage	V_{IH}	$V_{CC} = 3V$	$0.7 \times V_{DD}$			V
Input Low Voltage	V_{IL}	$V_{CC} = 3V$		$0.3 \times V_{DD}$		V
Input Leakage Current				± 1.0		μA
Input Capacitance				5.0		pF
TIMING CHARACTERISTICS (Voltage Divider Mode)						
Wiper Settling Time	t_{IL}	MAX5400 (to 50% of final value, from code 0 to code 128)	300			ns
		MAX5401 (to 50% of final value, from code 0 to code 128)	600			
TIMING CHARACTERISTICS (Digital) (Note 5)						
SCLK Clock Period	t_{CP}		100			ns
SCLK Pulse Width High	t_{CH}		40			ns
SCLK Pulse Width Low	t_{CL}		40			ns
\overline{CS} Fall to SCLK Rise Setup Time	t_{CSS}		40			ns
SCLK Rise to \overline{CS} Rise Hold Time	t_{CSH}		0			ns
DIN Setup Time	t_{DS}		40			ns
DIN Hold Time	t_{DH}		0			ns
SCLK Rise to \overline{CS} Fall Delay	t_{CS0}		10			ns
\overline{CS} Rise to SCLK Rise Hold	t_{CS1}		40			ns
\overline{CS} Pulse Width High	t_{CSW}		100			ns

Note 1: Linearity is defined in terms of the H to L code-dependent resistance.

Note 2: The DNL and INL are measured with the potentiometer configured as a voltage-divider with $H = V_{DD}$ and $L = 0$. The wiper terminal is unloaded and measured with an ideal voltmeter.

Note 3: The DNL and INL are measured with the potentiometer configured as a variable resistor. H is unconnected and $L = 0$. The wiper terminal is driven with a source current of $80\mu A$ for the $50k\Omega$ configuration and $40\mu A$ for the $100k\Omega$ configuration.

Note 4: The wiper resistance is measured assuming the source currents given in Note 2.

Note 5: Digital timing is guaranteed by design.

256-Tap SOT-PoT, Low-Drift Digital Potentiometers in SOT23

Typical Operating Characteristics

($T_A = +25^\circ\text{C}$, unless otherwise noted.)

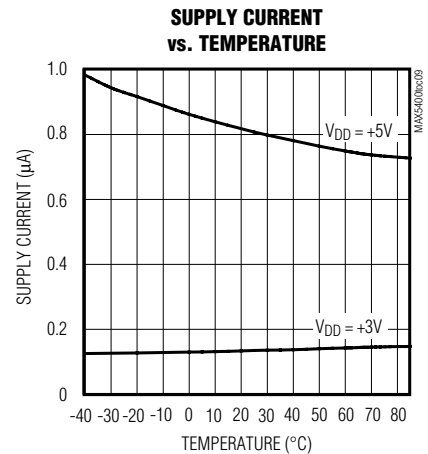
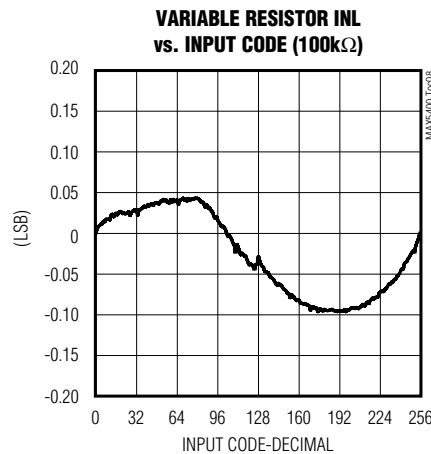
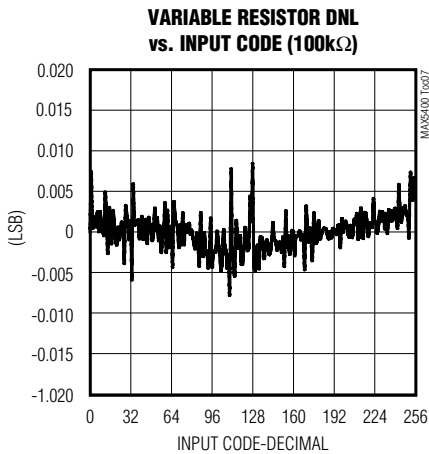
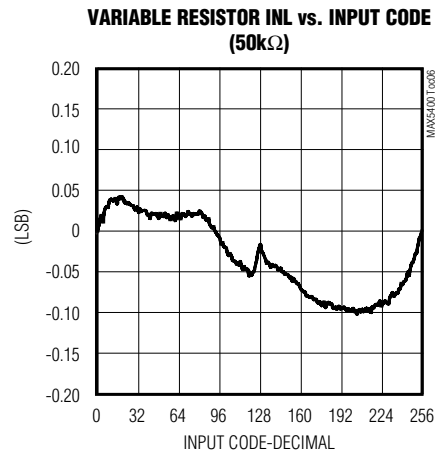
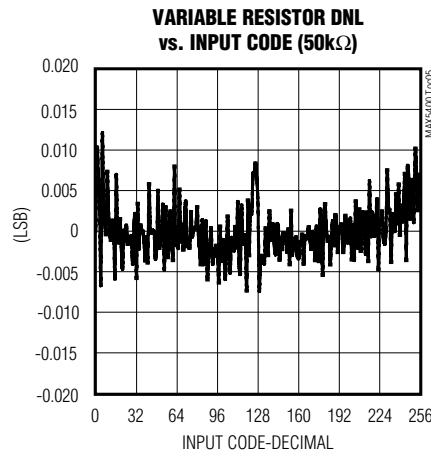
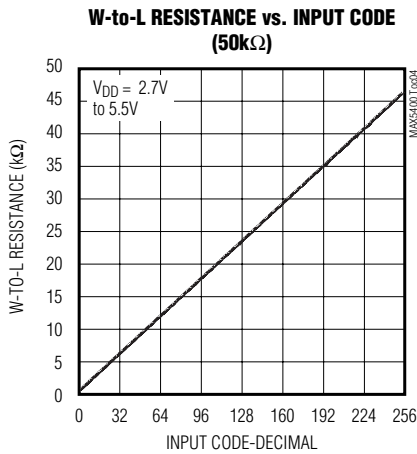
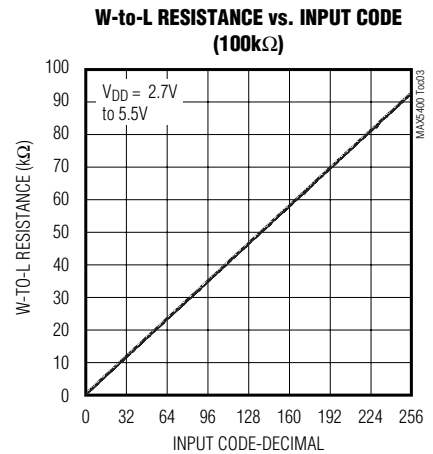
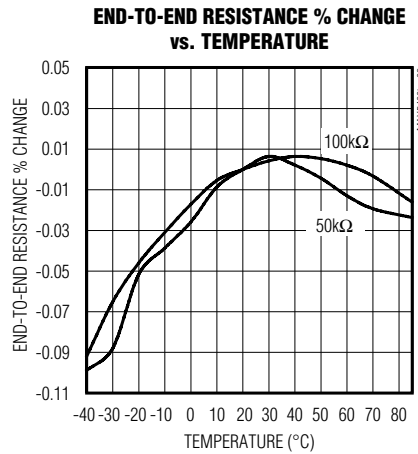
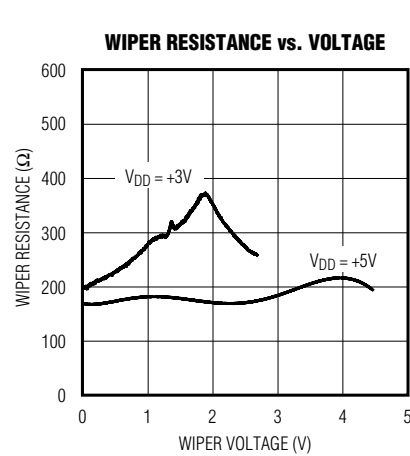

256-Tap SOT-PoT, Low-Drift Digital Potentiometers in SOT23

Typical Operating Characteristics (continued)

($T_A = +25^\circ\text{C}$, unless otherwise noted.)

MAX5400/MAX5401

**TAP-to-TAP SWITCHING TRANSIENT
(FROM CODE 127 to CODE 128)**

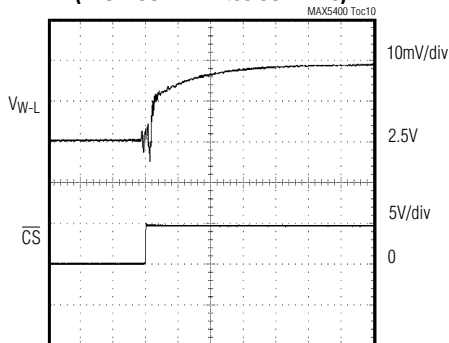

**SUPPLY CURRENT vs.
INPUT LOGIC VOLTAGE**

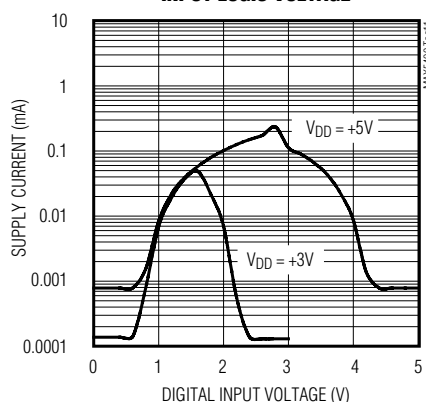

**VOLTAGE DIVIDER DNL
vs. INPUT CODE (50kΩ)**

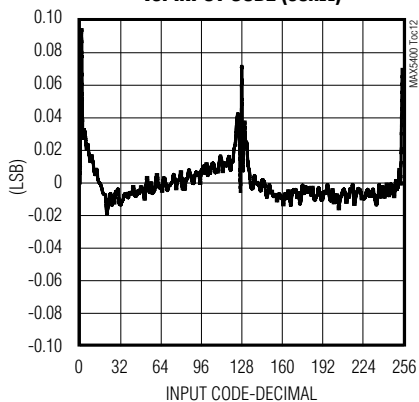

**VOLTAGE DIVIDER INL
vs. INPUT CODE (50kΩ)**

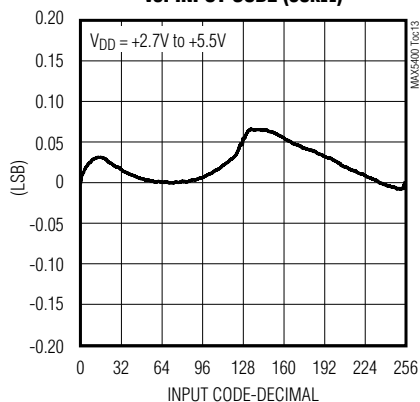

Pin Description

PIN	NAME	FUNCTION
1	L	Low Terminal of Resistor
2	GND	Ground
3	$\overline{\text{CS}}$	Chip Select Input
4	DIN	Serial Data Input
5	SCLK	Clock Input
6	V _{DD}	Power Supply. Bypass with a 0.1μF capacitor to GND.
7	W	Wiper Terminal
8	H	High Terminal of Resistor

256-Tap SOT-PoT, Low-Drift Digital Potentiometers in SOT23

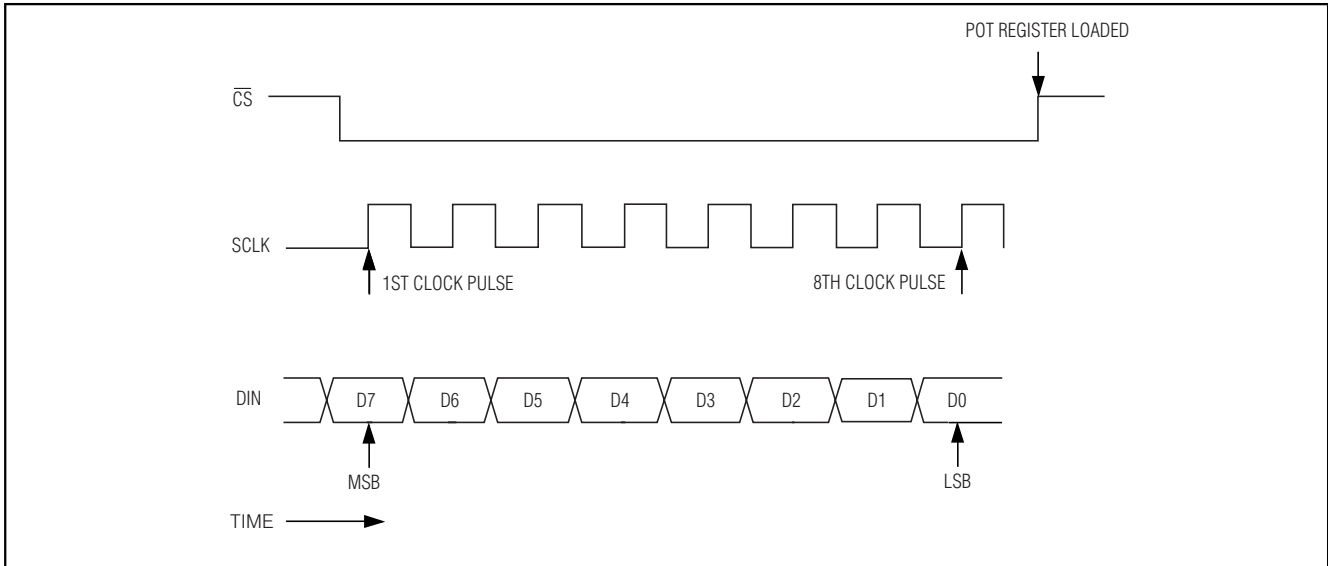

Figure 2. Serial Interface Timing Diagram

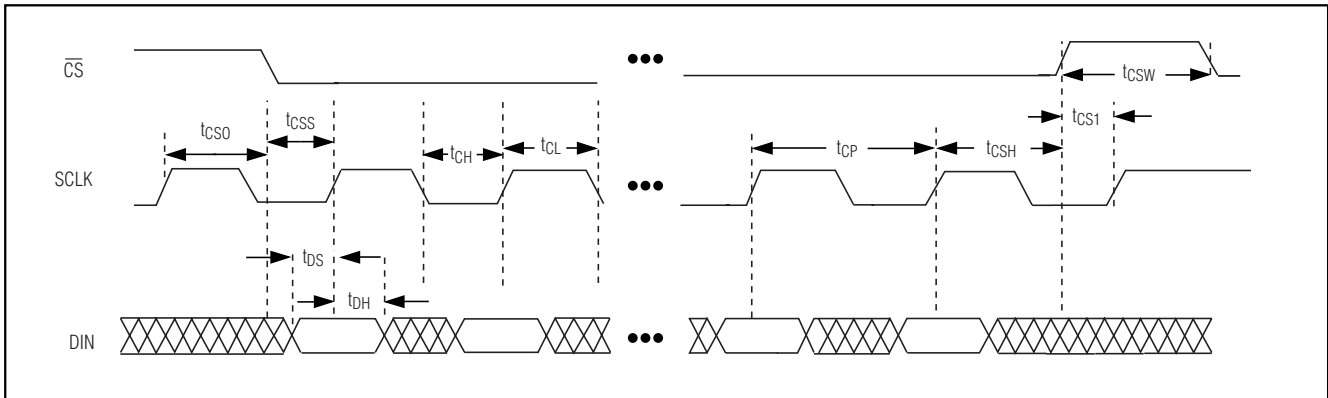

Figure 3. Detailed Serial Interface Timing Diagram

Detailed Description

The MAX5400/MAX5401 consists of 255 fixed resistors in series between pins H and L. The potentiometer wiper (pin W) can be programmed to access any one of the 256 different tap points on the resistor string. The MAX5400/MAX5401 uses a 3-wire serial data interface to control the wiper tap position. This write-only interface contains three inputs: Chip-Select (\overline{CS}), Data In (DIN), and Data Clock (SCLK). When \overline{CS} is taken low, data from the DIN pin is synchronously loaded into the 8-bit serial shift register on the rising edge of each SCLK pulse. The MSB is shifted in first as shown in Figure 4. Note that if \overline{CS} is not kept low during the entire data stream, the data will be corrupted and the device

will need to be reloaded. After all 8 data bits have been loaded into the shift register, they are latched into the decoder once \overline{CS} is taken high. The decoder switches the potentiometer wiper to the tap position that corresponds to the 8-bit input data. Each resistor cell is $50\text{k}\Omega/255$ or 196.1Ω for the MAX5400 and $100\text{k}\Omega/255$ or 392.2Ω for the MAX5401.

The MAX5400/MAX5401 feature power-on reset (POR) circuitry that sets the wiper to the midscale position at power-up by loading a binary value of 128 into the 8-bit latch.

The MAX5400/MAX5401 can be used as a variable resistor by connecting pin W to either pin H or pin L.

256-Tap SOT-PoT, Low-Drift Digital Potentiometers in SOT23

MAX5400/MAX5401

DATA WORD							
B0 (D7)	B1 (D6)	B2 (D5)	B3 (D4)	B4 (D3)	B5 (D2)	B6 (D1)	B7 (D0)
(MSB)							(LSB)
FIRST							LAST
BIT IN							BIT IN

Figure 4. Serial Data Format

Applications Information

The MAX5400/MAX5401 are intended for a variety of circuits that require accurate, fine-tuning adjustable resistance, such as adjustable voltage or adjustable gain circuit configurations. The MAX5400/MAX5401 are primarily used in either a potentiometer divider or a variable resistor configuration.

Adjustable Current-to-Voltage Converter

Figure 5 shows the MAX5400/MAX5401 being used with a MAX4250 low-noise op amp to fine tune a current-to-voltage converter. Pins H and W of the MAX5400/MAX5401 are connected to the node between R3 and R2 and pin L is connected to ground.

Adjustable Gain Amplifier

The MAX5400/MAX5401 are used again with the MAX4250 to make a digitally adjustable gain circuit as shown in Figure 6. The normal feedback resistor is replaced with the MAX5400/MAX5401 in a variable

resistor configuration so that the gain of the circuit can be digitally controlled.

Adjustable Voltage Reference

In Figure 7, the MAX5400/MAX5401 are shown with the MAX6160 to make an adjustable voltage reference. In this circuit, the H pin of the MAX5400/MAX5401 is connected to the OUT pin of the MAX6160, the L pin of the MAX5400/MAX5401 is connected to GND, and the W pin of the MAX5400/MAX5401 is connected to the ADJ pin of the MAX6160. The MAX5400/MAX5401 allow precise tuning of the voltage reference output. A low 5ppm/°C ratiometric tempco allows a very stable adjustable voltage over temperature.

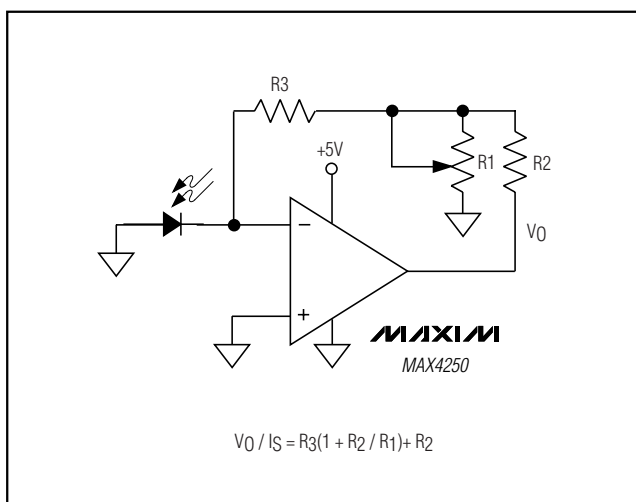

Figure 5. I to V Converter

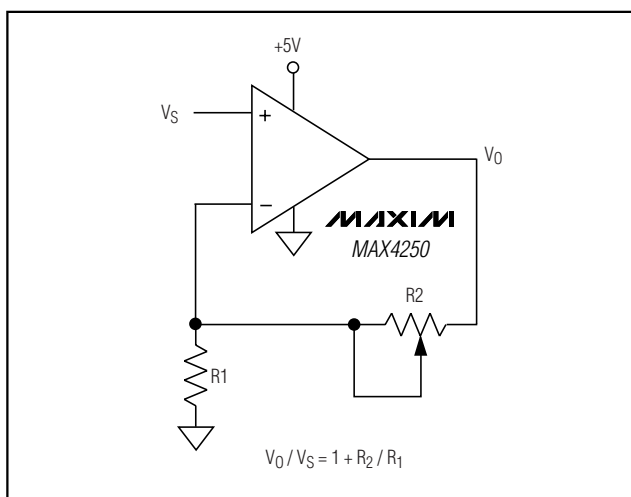

Figure 6. Noninverting Amplifier

256-Tap SOT-PoT, Low-Drift Digital Potentiometers in SOT23

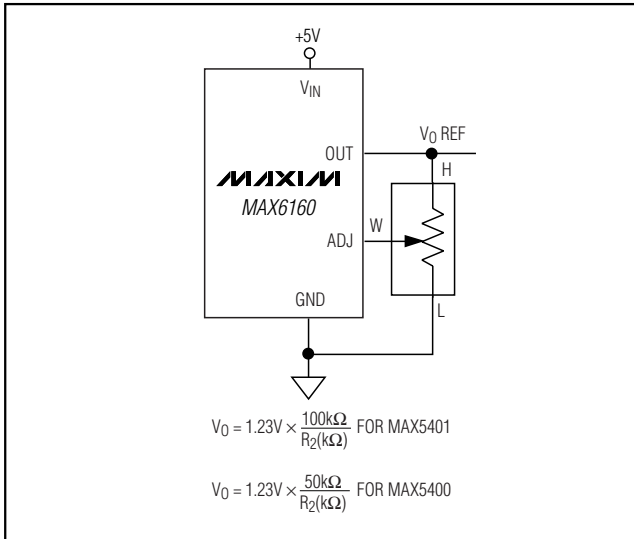
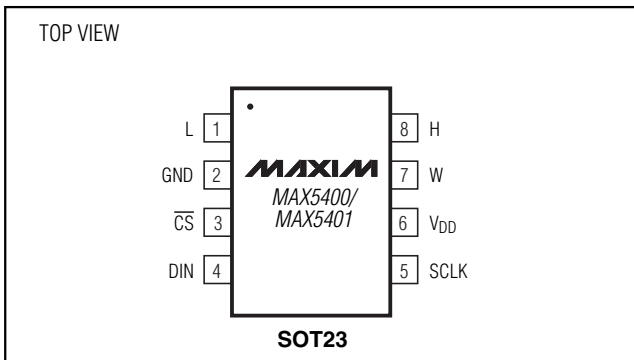

Figure 7. Adjustable Voltage Reference

Chip Information

TRANSISTOR COUNT: 3769
TECHNOLOGY: BiCMOS

Pin Configuration



Maxim cannot assume responsibility for use of any circuitry other than circuitry entirely embodied in a Maxim product. No circuit patent licenses are implied. Maxim reserves the right to change the circuitry and specifications without notice at any time.

8 **Maxim Integrated Products, 120 San Gabriel Drive, Sunnyvale, CA 94086 408-737-7600**