

White LED Step-Up Regulator

élantec.

The EL7513 is a constant current boost regulator specially designed for driving white LEDs. It can drive 4

LEDs in series or up to 12 LEDs in parallel/series configuration and achieves efficiency up to 91%.

The brightness of the LEDs is adjusted through a voltage level on the CNTL pin. When the level falls below 0.1V, the chip goes into shut-down mode and consumes less than 1µA of supply current for V_{IN} less than 5.5V.

The EL7513 is available in the 8-pin TSOT and 8-pin MSOP packages. The TSOT package is just 1mm high, compared to 1.45mm for the standard SOT23 package.

Ordering Information

PART NUMBER	PACKAGE	TAPE & REEL	PKG. DWG. #
EL7513IWT-T7	8-Pin TSOT	7" (3K pcs)	MDP0049
EL7513IWT-T7A	8-Pin TSOT	7" (250 pcs)	MDP0049
EL7513IWTZ-T7 (Note)	8-Pin TSOT (Pb-Free)	7" (3K pcs)	MDP0049
EL7513IWTZ-T7A (Note)	8-Pin TSOT (Pb-Free)	7" (250 pcs)	MDP0049
EL7513IY	8-Pin MSOP	-	MDP0043
EL7513IY-T7	8-Pin MSOP	7"	MDP0043
EL7513IY-T13	8-Pin MSOP	13"	MDP0043

NOTE: Intersil Pb-Free products employ special Pb-free material sets; molding compounds/die attach materials and 100% matte tin plate termination finish, which is compatible with both SnPb and Pb-free soldering operations. Intersil Pb-Free products are MSL classified at Pb-free peak reflow temperatures that meet or exceed the Pb-free requirements of IPC/JEDEC J Std-020B.

Features

- 2.6V to 13.2V input voltage
- 18V maximum output voltage
- Drives up to 12 LEDs
- 1MHz switching frequency
- Up to 91% efficiency
- 1µA maximum shut-down current
- Dimming control
- 8-pin TSOT and 8-pin MSOP packages

Applications

- PDAs
- Cellular phones
- Digital cameras
- White LED backlighting



EL7513

Pinouts

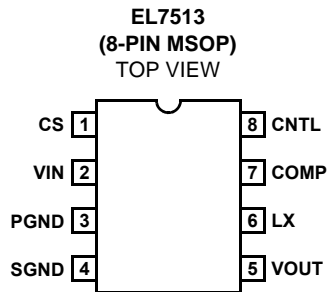
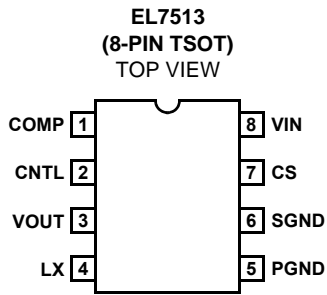

Typical Connection

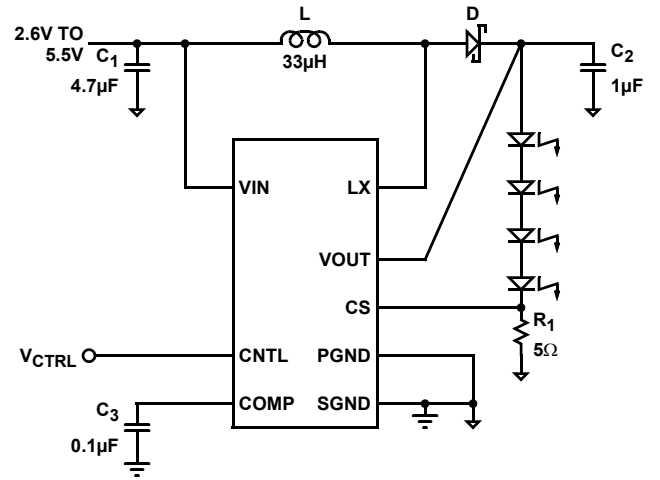

EL7513

Absolute Maximum Ratings (T_A = 25°C)

COMP, CNTL, CS to SGND -0.3V to +6V	SGND to PGND -0.3V to +0.3V
V _{IN} to SGND +14V	Storage Temperature -65°C to +150°C
V _{OUT} to SGND +19V	Ambient Operating Temperature -40°C to +85°C
LX to PGND +20V	

CAUTION: Stresses above those listed in "Absolute Maximum Ratings" may cause permanent damage to the device. This is a stress only rating and operation of the device at these or any other conditions above those indicated in the operational sections of this specification is not implied. This part is ESD sensitive. Handle with care.

IMPORTANT NOTE: All parameters having Min/Max specifications are guaranteed. Typ values are for information purposes only. Unless otherwise noted, all tests are at the specified temperature and are pulsed tests, therefore: T_J = T_C = T_A

Electrical Specifications V_{IN} = 3V, V_O = 12V, C₁ = 4.7μF, L = 33μH, C₂ = 1μF, C₃ = 0.1μF, R₁ = 5Ω, T_A = 25°C, Unless Otherwise Specified

PARAMETER	DESCRIPTION	CONDITIONS	MIN	TYP	MAX	UNIT
V _{IN}	Input Voltage		2.6		13.2	V
I _{Q1}	Total Input Current at Shut-down	V _{CNTL} = 0V			1	μA
I _{Q1}	Quiescent Supply Current at V _O Pin	V _{CNTL} = 1V, load disconnected		1	1.5	mA
I _{COMP}	COMP Pin Pull-up Current	COMP connected to SGND		11	20	μA
V _{COMP}	COMP Voltage Swing		0.5	1.5	2.5	V
I _{CNTL}	CNTL Shut-down Current	CNTL = 0V			1	μA
V _{CNTL1}	Chip Enable Voltage		240			mV
V _{CNTL2}	Chip Disable Voltage				100	mV
I _{OUT_ACCURACY}	V _{CNTL} = 1V	V _{CNTL} = 1V	14	15	16	mA
V _{OUT1}	Over-voltage Threshold	V _{OUT} rising	17	18	19	V
V _{OUT2}	Over-voltage Threshold	V _{OUT} falling, with resistive load	15	16	17.5	V
I _{LX}	MOSFET Current Limit		500			mA
R _{DS_ON}	MOSFET On-resistance			0.7		Ω
I _{LEAK}	MOSFET Leakage Current	V _{CNTL} = 0V, V _{LX} = 12V			1	μA
F _S	Switching Frequency		800	1000	1200	kHz
D _{MAX}	Maximum Duty Ratio	V _{CNTL} = 2V, I _S = 0	85	90		%
I _{CS}	CS Input Bias Current				1	μA
ΔI _O /ΔV _{IN}	Line Regulation	V _{IN} = 2.6V - 5.5V		0.03		%/V

Pin Descriptions

8-PIN TSOT	8-PIN MSOP	PIN NAME	DESCRIPTION
1	7	COMP	Compensation pin. A compensation cap (4700pF to 1μF) is normally connected between this pin and SGND.
2	8	CNTL	Control pin for dimming and shut-down. A voltage between 250mV and 5.5V controls the brightness, and less than 100mV shuts down the converter.
3	5	VOUT	Output voltage sense. Use for over voltage protection.
4	6	LX	Inductor connection pin. The drain of internal MOSFET.
5	3	PGND	Power Ground pin. The source of internal MOSFET.
6	4	SGND	Signal Ground. Ground pin for internal control circuitry. Needs to connect to PGND at only one point.
7	1	CS	Current sense pin. Connect to sensing resistor to set the LED bias current.
8	2	VIN	Power supply for internal control circuitry.

Block Diagram

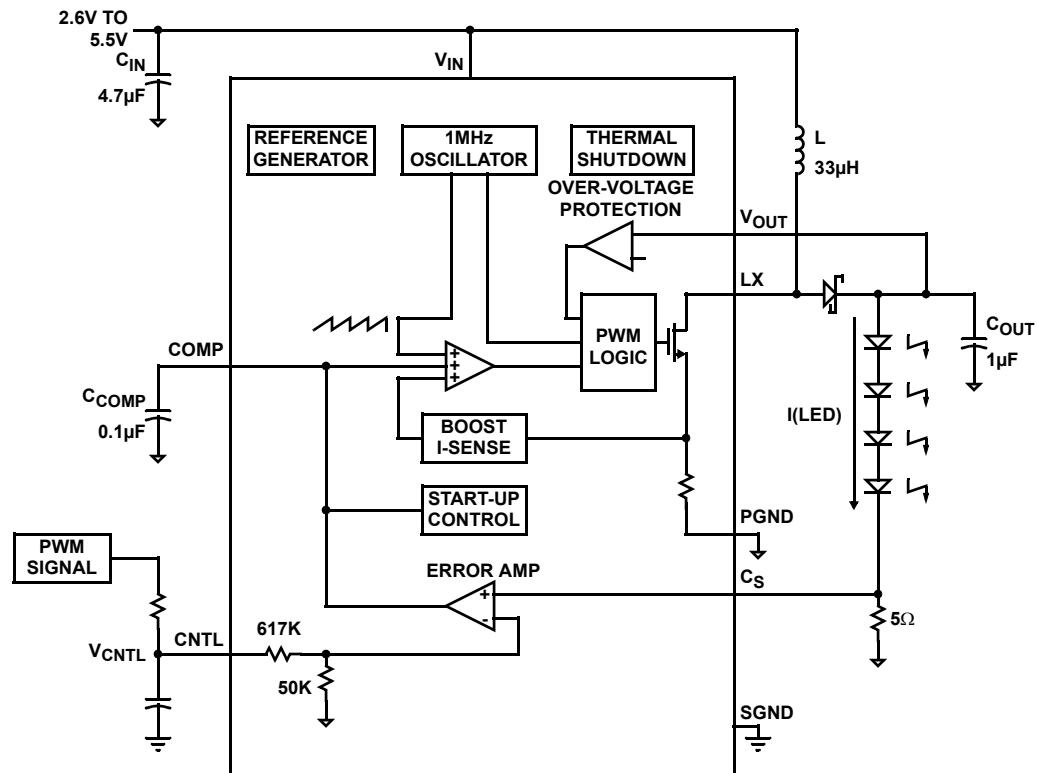

Typical Performance Curves

All performance curves and waveforms are taken with $C_1 = 4.7\mu\text{F}$, $C_2 = 1\mu\text{F}$, $C_3 = 0.1\mu\text{F}$, $L = 33\mu\text{H}$, $V_{IN} = 3.3\text{V}$, $V_{CTRL} = 1\text{V}$, $R_1 = 5\Omega$, 4 LEDs in a series; unless otherwise specified.

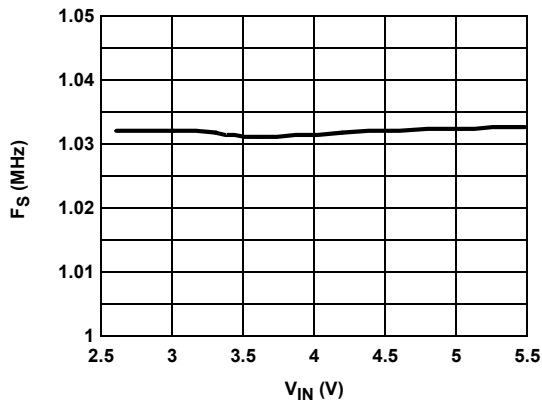

FIGURE 1. SWITCHING FREQUENCY vs V_{IN}

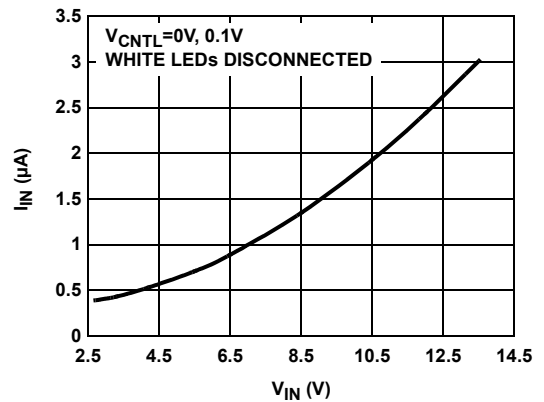

FIGURE 2. QUIESCENT CURRENT

Typical Performance Curves (Continued)

All performance curves and waveforms are taken with $C_1 = 4.7\mu\text{F}$, $C_2 = 1\mu\text{F}$, $C_3 = 0.1\mu\text{F}$, $L = 33\mu\text{F}$, $V_{IN} = 3.3\text{V}$, $V_{CNTL} = 1\text{V}$, $R_1 = 5\Omega$, 4 LEDs in a series; unless otherwise specified.

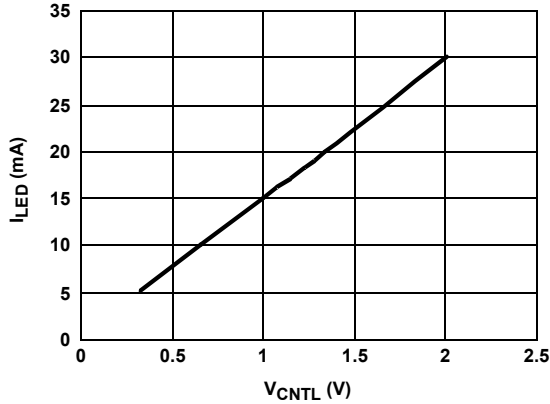

FIGURE 3. I_{LED} vs V_{CNTL}

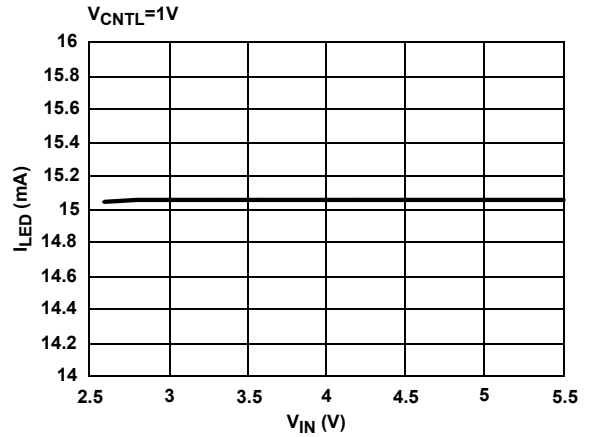

FIGURE 4. I_{LED} vs V_{IN}

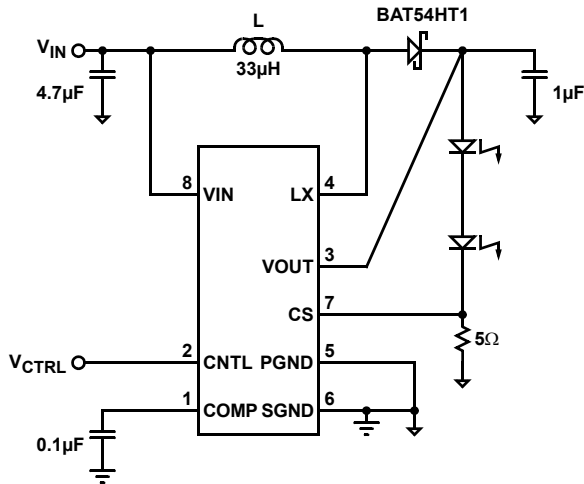

FIGURE 5A. 2 LEDs IN A SERIES

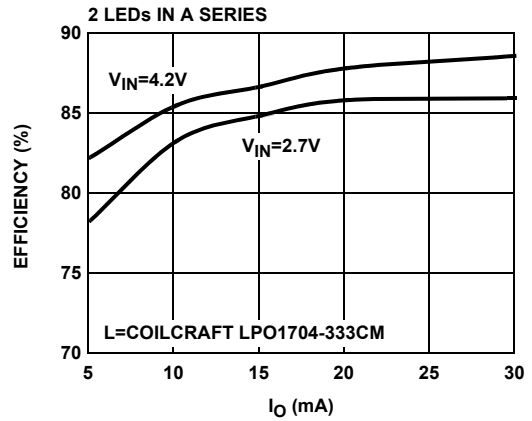

FIGURE 5B. EFFICIENCY vs I_O

FIGURE 5.

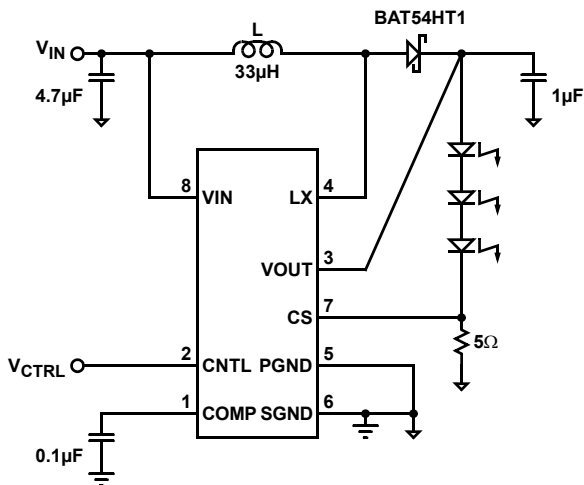

FIGURE 6A. 3 LEDs IN A SERIES

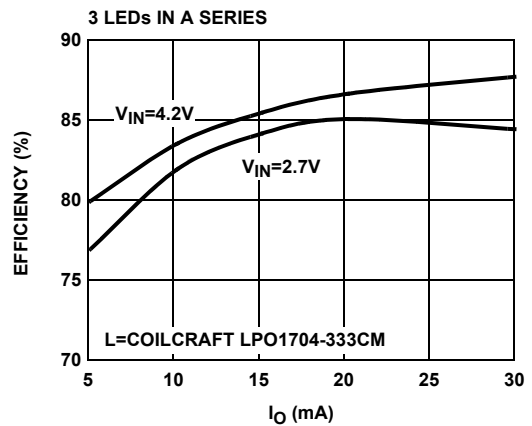

FIGURE 6B. EFFICIENCY vs I_O

FIGURE 6.

Typical Performance Curves (Continued)

All performance curves and waveforms are taken with $C_1 = 4.7\mu\text{F}$, $C_2 = 1\mu\text{F}$, $C_3 = 0.1\mu\text{F}$, $L = 33\mu\text{H}$, $V_{IN} = 3.3\text{V}$, $V_{CNTL} = 1\text{V}$, $R_1 = 5\Omega$, 4 LEDs in a series; unless otherwise specified.

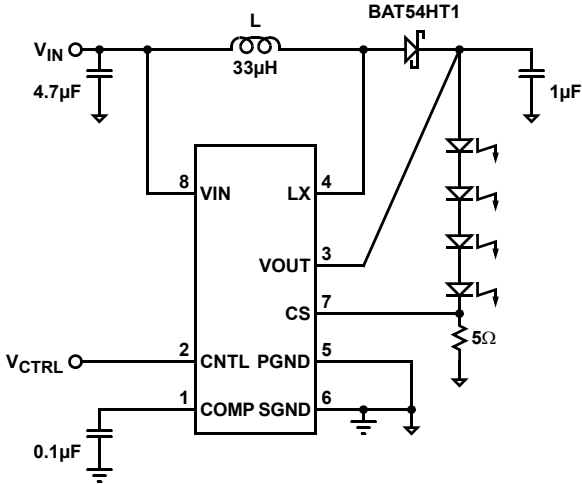

FIGURE 7A. 4 LEDs IN A SERIES

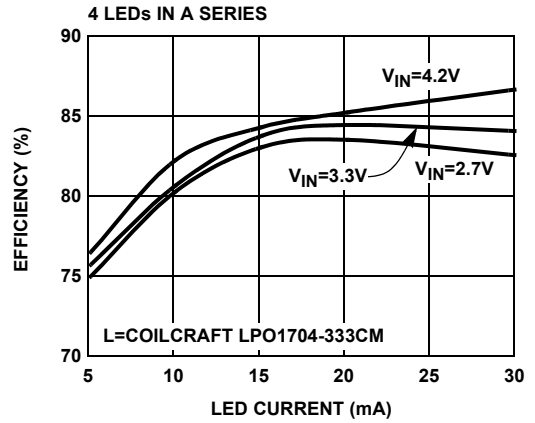

FIGURE 7.

FIGURE 7B. EFFICIENCY vs I_O

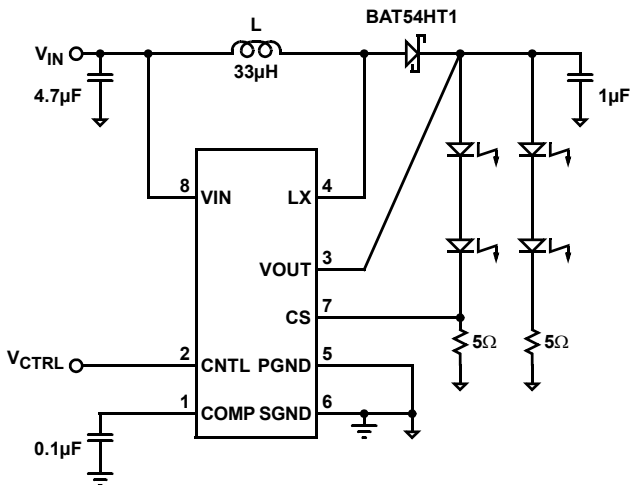

FIGURE 8A. 2 LEGS OF 2 LEDs IN A SERIES

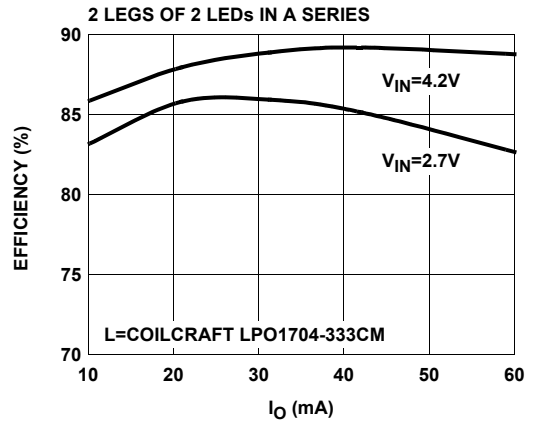

FIGURE 8.

FIGURE 8B. EFFICIENCY vs I_O

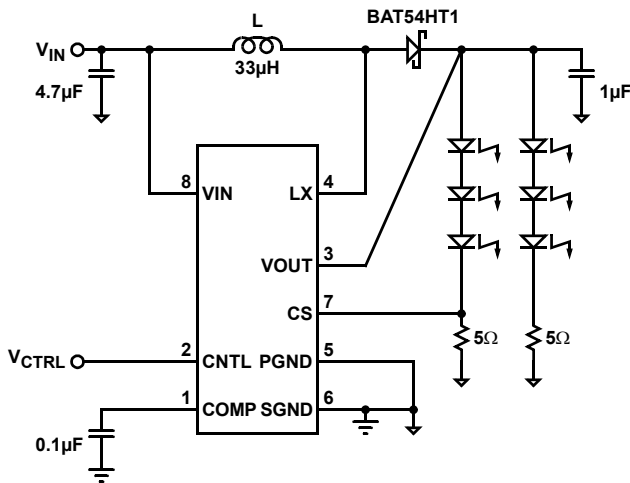

FIGURE 9A. 2 LEGS OF 3 LEDs IN A SERIES

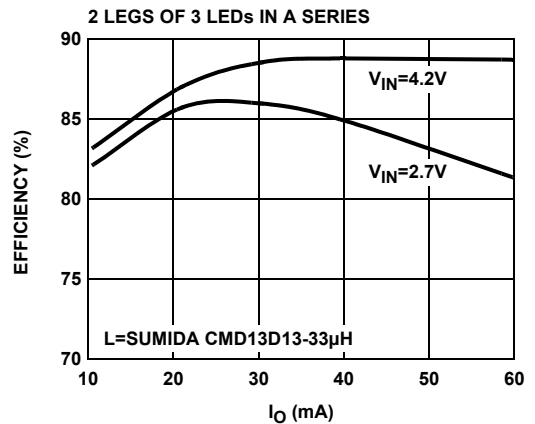

FIGURE 9.

FIGURE 9B. EFFICIENCY vs I_O

Typical Performance Curves (Continued)

All performance curves and waveforms are taken with $C_1 = 4.7\mu\text{F}$, $C_2 = 1\mu\text{F}$, $C_3 = 0.1\mu\text{F}$, $L = 33\mu\text{H}$, $V_{IN} = 3.3\text{V}$, $V_{CNTL} = 1\text{V}$, $R_1 = 5\Omega$, 4 LEDs in a series; unless otherwise specified.

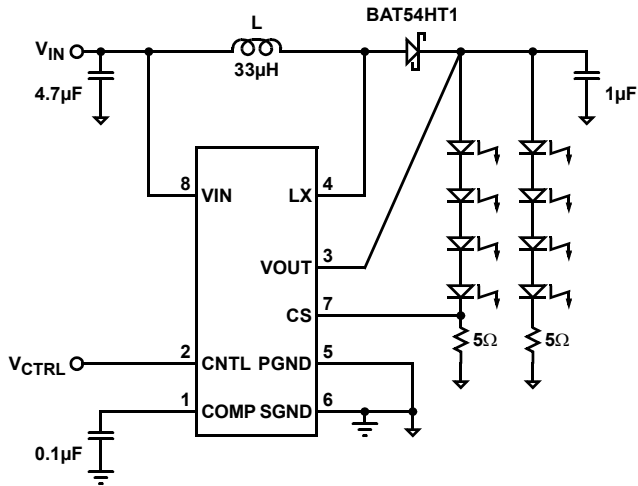

FIGURE 10A. 2 LEGS OF 4 LEDs IN A SERIES

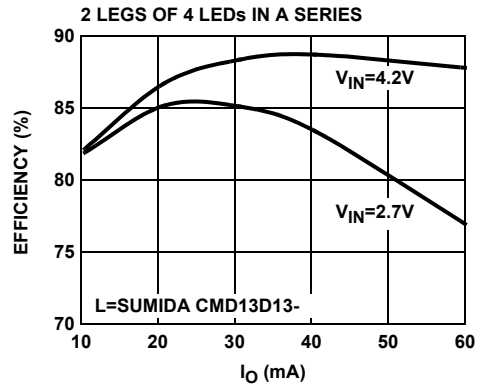

FIGURE 10.

FIGURE 10B. EFFICIENCY vs I_O

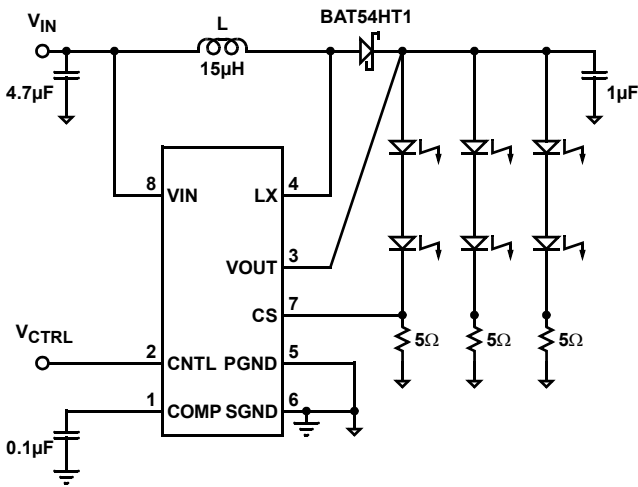

FIGURE 11A. 3 LEGS OF 2 LEDs IN A SERIES

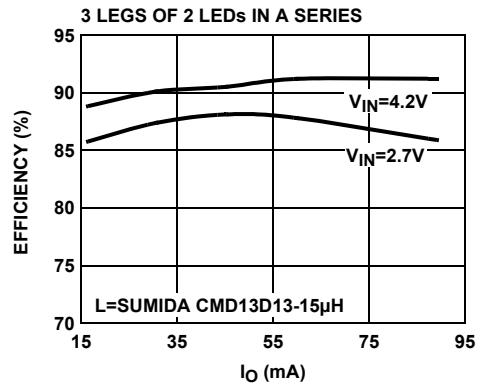

FIGURE 11.

FIGURE 11B. EFFICIENCY vs I_O

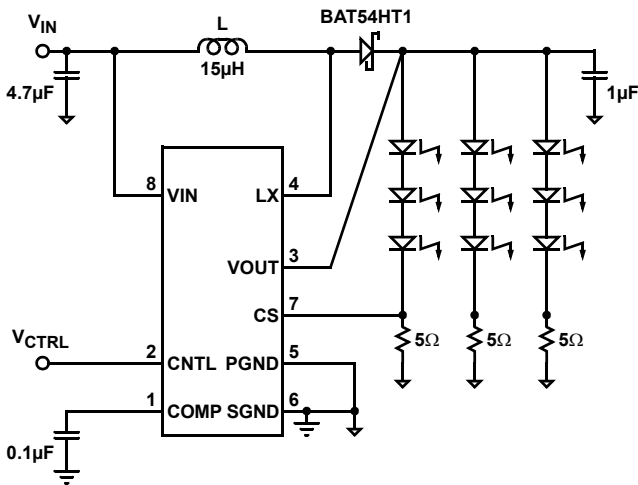

FIGURE 12A. 3 LEGS OF 3 LEDs IN A SERIES

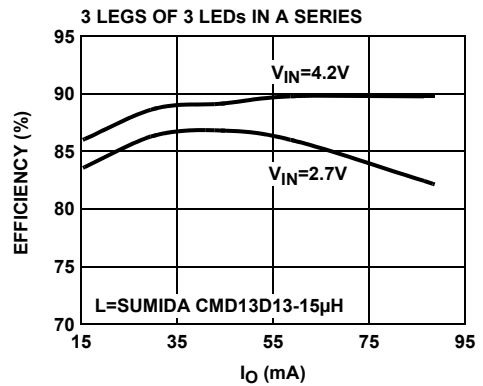

FIGURE 12.

FIGURE 12B. EFFICIENCY vs I_O

Typical Performance Curves (Continued)

All performance curves and waveforms are taken with $C_1 = 4.7\mu\text{F}$, $C_2 = 1\mu\text{F}$, $C_3 = 0.1\mu\text{F}$, $L = 33\mu\text{H}$, $V_{\text{IN}} = 3.3\text{V}$, $V_{\text{CNTL}} = 1\text{V}$, $R_1 = 5\Omega$, 4 LEDs in a series; unless otherwise specified.

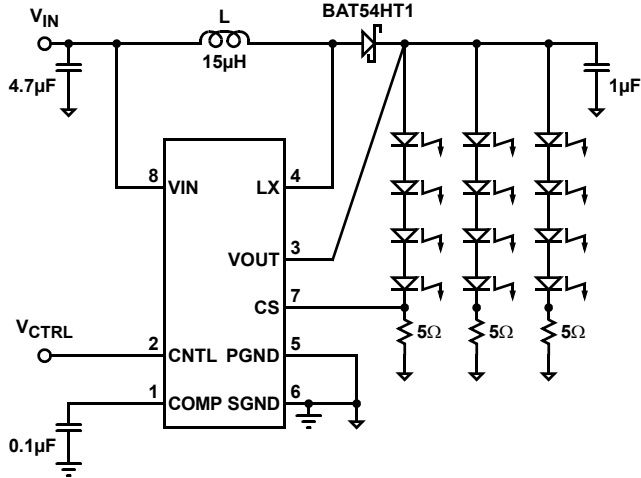

FIGURE 13A. 3 LEGS of 4 LEDs in a SERIES

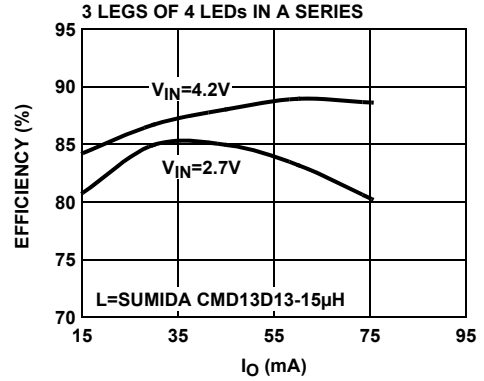

FIGURE 13.

FIGURE 13B. EFFICIENCY vs I_O

Waveforms

All performance curves and waveforms are taken with $C_1 = 4.7\mu\text{F}$, $C_2 = 1\mu\text{F}$, $C_3 = 0.1\mu\text{F}$, $L = 33\mu\text{H}$, $V_{\text{IN}} = 3.3\text{V}$, $V_{\text{CNTL}} = 1\text{V}$, $R_1 = 5\Omega$, 4 LEDs in a series; unless otherwise specified.

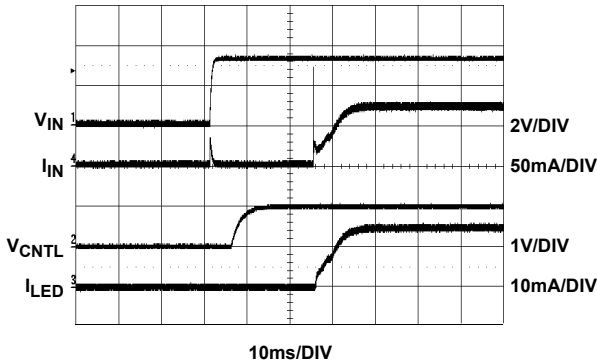

FIGURE 14. START-UP

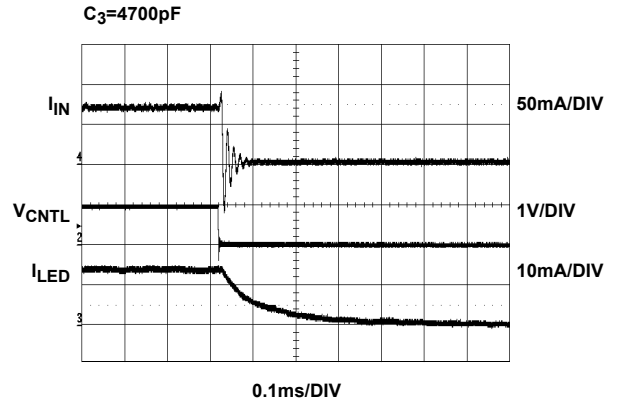

FIGURE 15. SHUT-DOWN

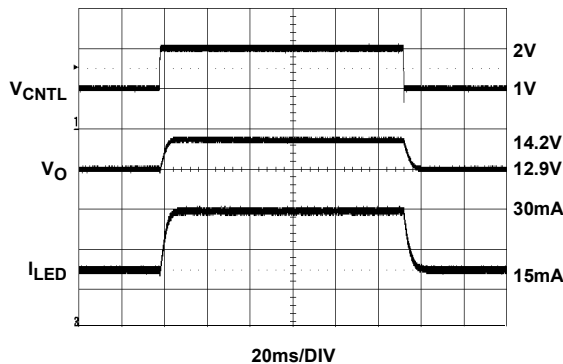

FIGURE 16. TRANSIENT RESPONSE

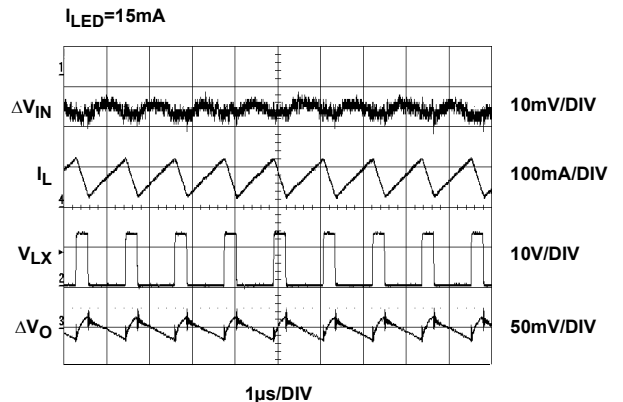

FIGURE 17. CONTINUOUS CONDUCTION MODE

Waveforms (Continued)

All performance curves and waveforms are taken with $C_1 = 4.7\mu\text{F}$, $C_2 = 1\mu\text{F}$, $C_3 = 0.1\mu\text{F}$, $L = 33\mu\text{F}$, $V_{\text{IN}} = 3.3\text{V}$, $V_{\text{CNTL}} = 1\text{V}$, $R_1 = 5\Omega$, 4 LEDs in a series; unless otherwise specified.

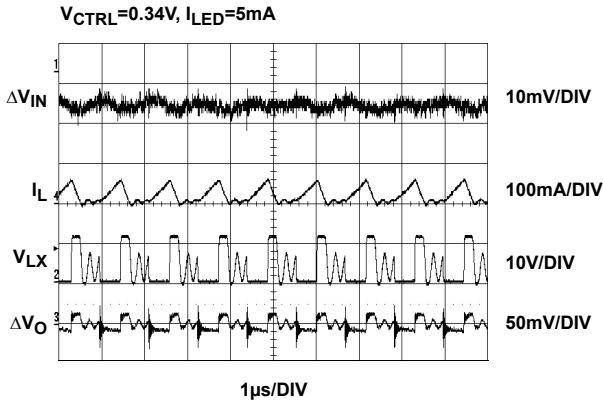

FIGURE 18. DISCONTINUOUS CONDUCTION MODE

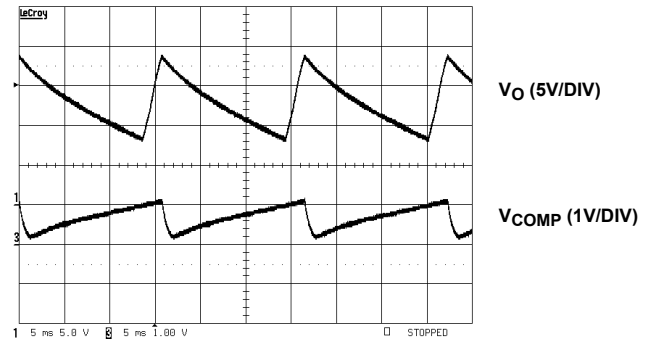

FIGURE 19. OVER VOLTAGE PROTECTION (LED DISCONNECTED)

Detailed Description

The EL7513 is a constant current boost regulator specially designed for driving white LEDs. It can drive up to 4 LEDs in series or 12 LEDs in parallel/series configuration and achieves efficiency up to 91%.

The brightness of the LEDs is adjusted through a voltage level on the CNTL pin. When the level falls below 0.1V, the chip goes into shut-down mode and consumes less than 1μA of current for V_{IN} less than 5.5V.

Steady-State Operation

EL7513 is operated in constant frequency PWM. The switching is around 1MHz. Depending on the input voltage, the inductance, the type of LEDs driven, and the LED's current, the converter operates at either continuous conduction mode or discontinuous conduction mode (see waveforms). Both are normal.

Brightness Control

LED's current is controlled by the voltage level on CNTL pin (V_{CNTL}). This voltage can be either a DC or a PWM signal with frequency less than 200Hz (for $C_3=4700\text{pF}$). When a higher frequency PWM is used, an RC filter is recommended before the CNTL pin (see Figure 20).

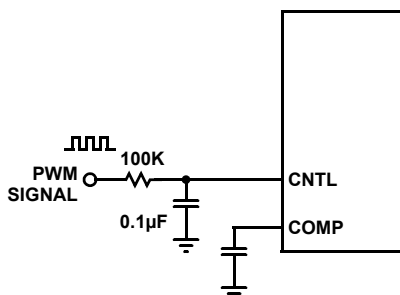

FIGURE 20. PWM BRIGHTNESS CONTROL

The relationship between the LED current and CNTL voltage level is as follows:

$$I_{\text{LED}} = \frac{V_{\text{CNTL}}}{13.33 \times R_1}$$

When R_1 is 5Ω, 1V of V_{CNTL} conveniently sets I_{LED} to 15mA. The range of V_{CNTL} is 250mV to 5.5V.

Shut-Down

When V_{CNTL} is less than 100mV, the converter is in shut-down mode. The max current consumed by the chip is less than 1μA for V_{IN} less than 5.5V.

Over-Voltage Protection

When an LED string is disconnected from the output, V_{O} will continue to rise because of no current feedback. When V_{O} reaches 18V (nominal), the chip will shut down. The output voltage will drop. When V_{O} drops below 16V (nominal), the chip will boost output voltage again until it reaches 18V. This hiccup continues until LED is applied or converter is shut down.

When designing the converter, caution should be taken to ensure the highest operating LED voltage does not exceed 17V, the minimum shut-down voltage. There is no external component required for this function.

Component Selection

The input and output capacitors are not very important for the converter to operate normally. The input capacitance is normally 0.22μF - 4.7μF and output capacitance 0.22μF - 1μF. Higher capacitance is allowed to reduce the voltage/current ripple, but at added cost. Use X5R or X7R type (for its good temperature characteristics) of ceramic capacitors with correct voltage rating and maximum height.

When choosing an inductor, make sure the inductor can handle the average and peak currents giving by following formulas (80% efficiency assumed):

$$I_{LAVG} = \frac{I_O \times V_O}{0.8 \times V_{IN}}$$

$$I_{LPK} = I_{LAVG} + \frac{1}{2} \times \Delta I_L$$

$$\Delta I_L = \frac{V_{IN} \times (V_O - V_{IN})}{L \times V_O \times F_S}$$

where:

- ΔI_L is the peak-to-peak inductor current ripple in Ampere
- L inductance in μH
- F_S switching frequency, typical 1MHz

A wide range of inductance (6.8 μH - 68 μH) can be used for the converter to function correctly. For the same series of inductors, the lower inductance has lower DC resistance (DCR), which has less conducting loss. But the ripple current is bigger, which generates more RMS current loss. Figure 11 shows the efficiency of the demo board under different inductance for a specific series of inductor. For optimal efficiency in an application, it is a good exercise to check several adjacent inductance values of your preferred series of inductors.

For the same inductance, higher overall efficiency can be obtained by using lower DCR inductor.

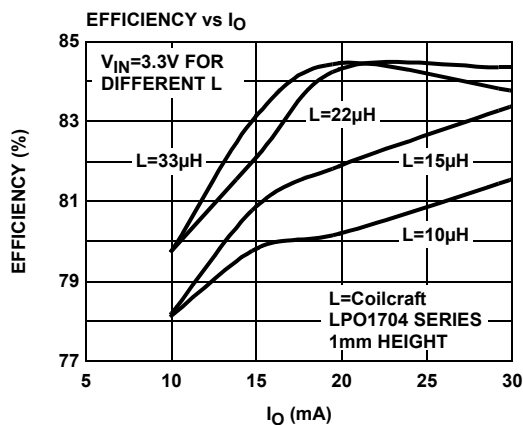

FIGURE 21. EFFICIENCY OF DIFFERENT INDUCTANCE (4 LEDs IN A SERIES)

The diode should be Schottky type with minimum reverse voltage of 20V. The diode's peak current is the same as inductor's peak current, the average current is I_O , and RMS current is:

$$I_{DRMS} = \sqrt{I_{LAVG} \times I_O}$$

Ensure the diode's ratings exceed these current requirements.

White LED Connections

One leg of LEDs connected in series will ensure the uniformity of the brightness. 18V maximum voltage enables 4 LEDs can be placed in series.

However, placing LEDs into series/parallel connection can give higher efficiency as shown in the efficiency curves. One of the ways to ensure the brightness uniformity is to pre-screen the LEDs.

PCB Layout Considerations

The layout is very important for the converter to function properly. Power Ground (\downarrow) and Signal Ground (\perp) should be separated to ensure the high pulse current in the power ground does not interference with the sensitive signals connected to Signal Ground. Both grounds should only be connected at one point right at the chip. The heavy current paths (V_{IN} -L-L χ pin-PGND, and V_{IN} -L-D-C $_2$ -PGND) should be as short as possible.

The trace connected to the CS pin is most important. The current sense resistor R_1 should be very close to the pin. When the trace is long, use a small filter capacitor close to the CS pin.

The heat of the IC is mainly dissipated through the PGND pin. Maximizing the copper area around the plane is preferable. In addition, a solid ground plane is always helpful for the EMI performance.

The demo board is a good example of layout based on the principle. Please refer to the EL7513 Application Brief for the layout.

Package Outline Drawing

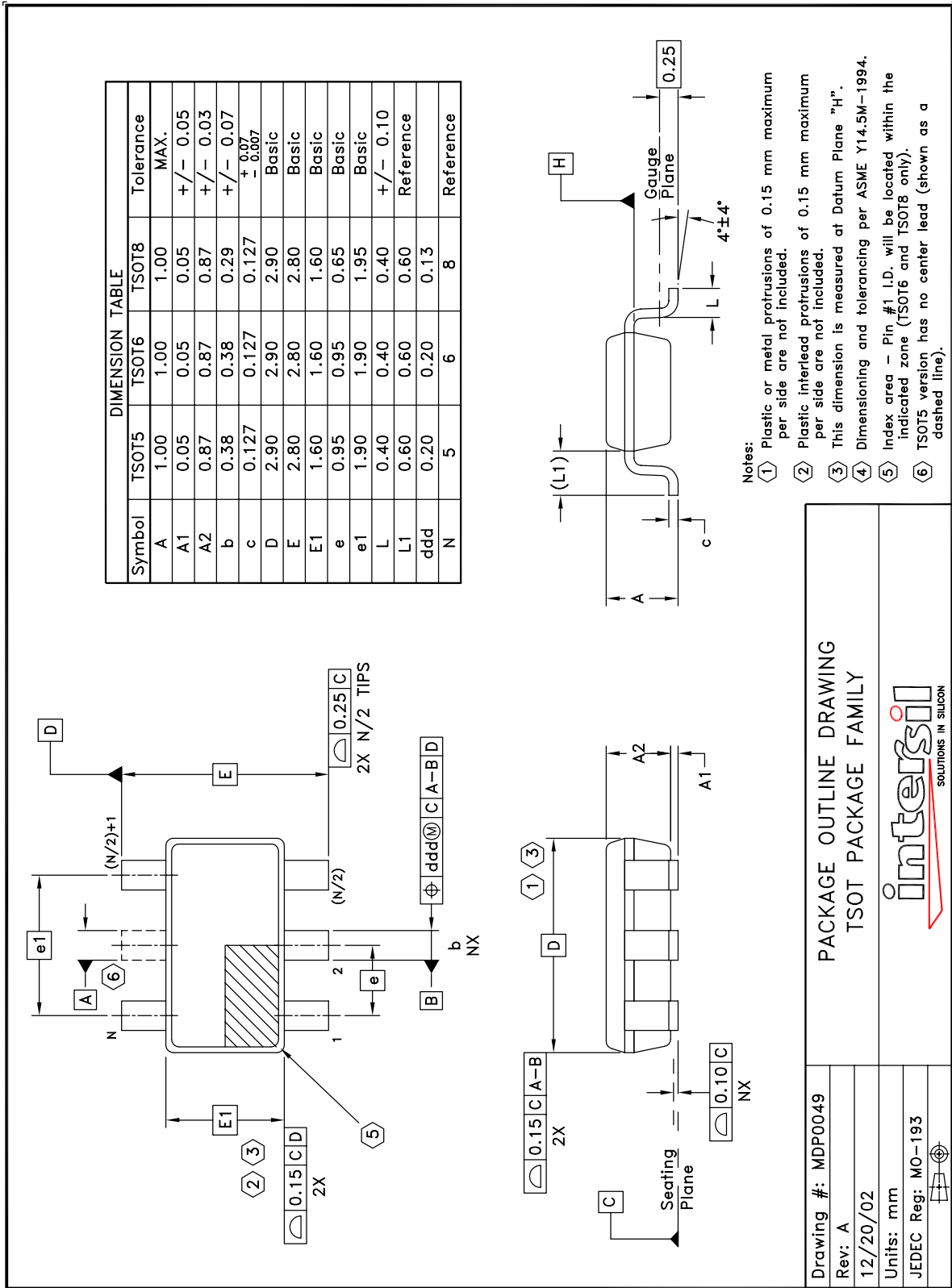

NOTE: The package drawing shown here may not be the latest version. To check the latest revision, please refer to the Intersil website at <<http://www.intersil.com/design/packages/index.asp>>

PACKAGE OUTLINE DRAWING
TSOT PACKAGE FAMILY

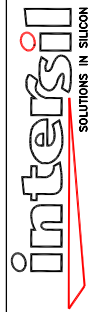

Drawing #: MDP0049

Rev: A

12/20/02

Units: mm

JEDEC Reg: MO-193



Package Outline Drawing

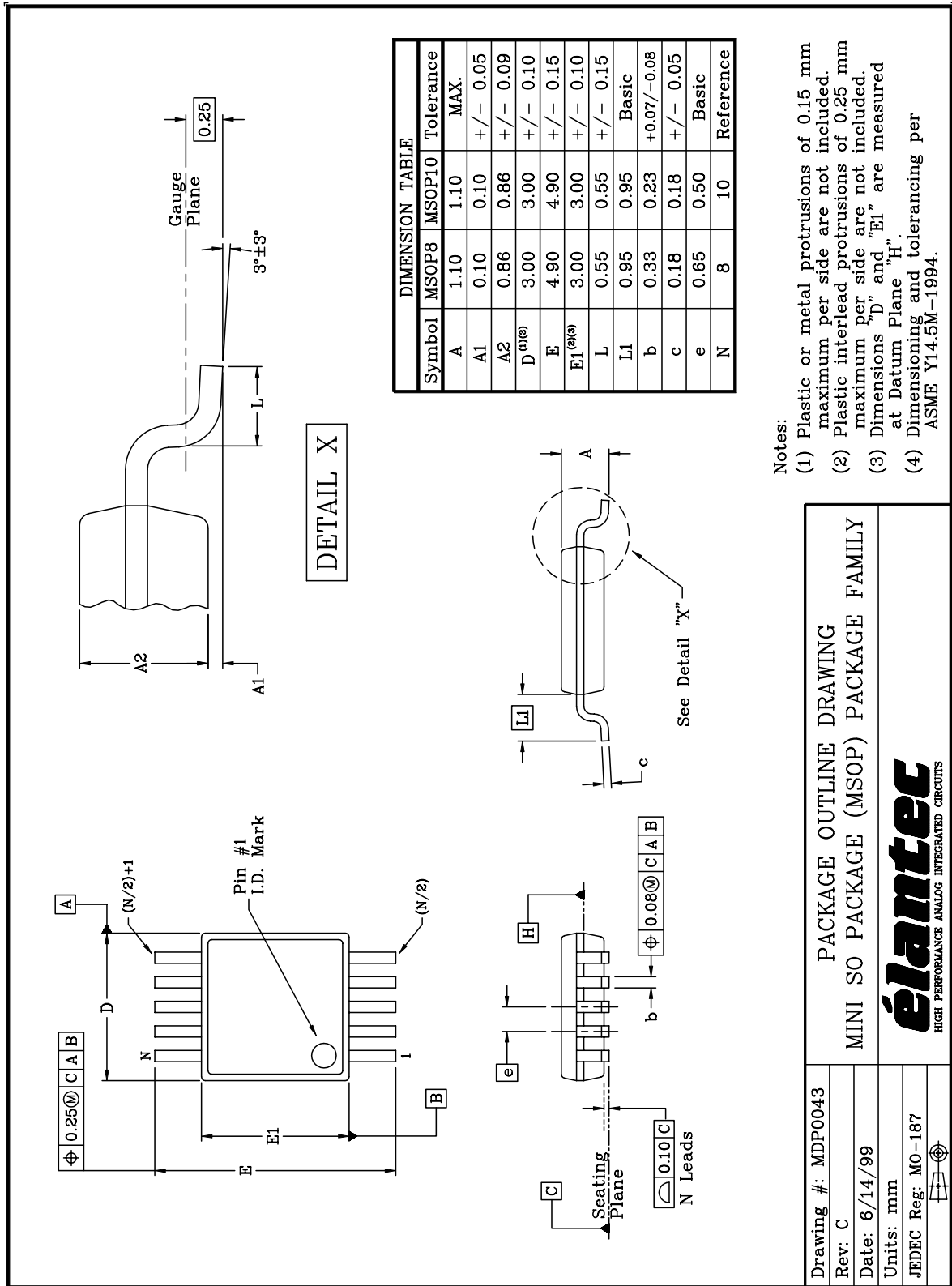

Drawing #: MDP0043	PACKAGE OUTLINE DRAWING MINI SO PACKAGE (MSOP) PACKAGE FAMILY
Rev: C	
Date: 6/14/99	 HIGH PERFORMANCE ANALOG INTEGRATED CIRCUITS
Units: mm	
JEDEC Reg: MO-187	

NOTE: The package drawing shown here may not be the latest version. To check the latest revision, please refer to the Intersil website at <<http://www.intersil.com/design/packages/index.asp>>

EL7513

All Intersil U.S. products are manufactured, assembled and tested utilizing ISO9000 quality systems.
Intersil Corporation's quality certifications can be viewed at www.intersil.com/design/quality

Intersil products are sold by description only. Intersil Corporation reserves the right to make changes in circuit design, software and/or specifications at any time without notice. Accordingly, the reader is cautioned to verify that data sheets are current before placing orders. Information furnished by Intersil is believed to be accurate and reliable. However, no responsibility is assumed by Intersil or its subsidiaries for its use; nor for any infringements of patents or other rights of third parties which may result from its use. No license is granted by implication or otherwise under any patent or patent rights of Intersil or its subsidiaries.

For information regarding Intersil Corporation and its products, see www.intersil.com
