

EM128L08 Family

128Kx8 Bit Ultra-Low Power Asynchronous Static RAM

Overview

The EM128L08 is an integrated memory device containing a low power 1 Mbit Static Random Access Memory organized as 131,072 words by 8 bits. The device is fabricated using NanoAmp's advanced CMOS process and high-speed/low-power circuit technology. This device is designed for very low voltage operation making it quite suitable for battery powered devices. It is also designed for both very low operating and standby-currents. The device pinout is compatible with other standard 128Kx8 SRAMs.

Features

- **Wide Voltage Range:**
2.3 to 3.6 Volts
- **Extended Temperature Range:**
-40 to +85 °C
- **Fast Cycle Time:**
 $T_{ACC} < 55 \text{ ns @ } 3.0\text{V}$
- **Very Low Operating Current:**
 $I_{CC} < 10 \text{ mA typical at } 3\text{V, } 10 \text{ Mhz}$
- **Very Low Standby Current:**
 $I_{SB} < 10 \mu\text{A @ } 55 \text{ }^\circ\text{C}$
- **32-Pin TSOP, STSOP, Packages Available**

FIGURE 1: Typical Operating Current Curves

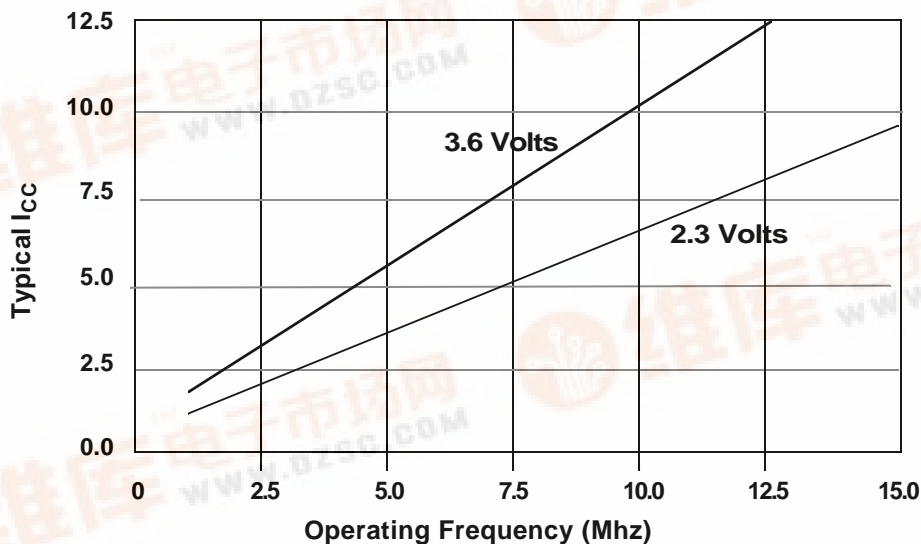

FIGURE 1: Pin Configuration



FIGURE 2: Functional Block Diagram

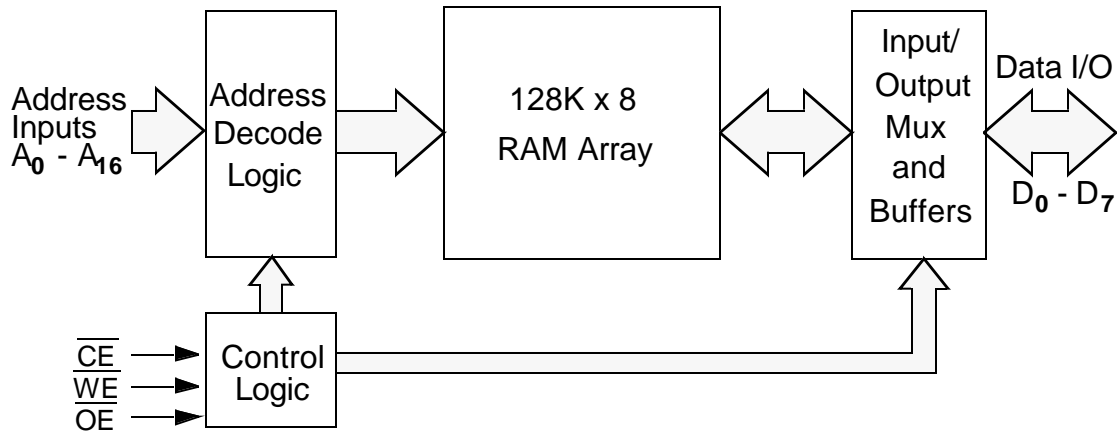

TABLE 1: Pin Description

Pin Name	Pin Function	Pin Name	Pin Function
A0-A16	Address Inputs	\overline{WE}	Write Enable (Active Low)
D0-D7	Data Inputs/Outputs	V _{CC}	Power
\overline{CE}	Chip Enable (Active Low)	V _{SS}	Ground
OE	Output Enable (Active Low)	NC	Not Connected (Do not connect signal)

TABLE 2: Functional Description

$\overline{CE}1$	CE2	\overline{WE}	\overline{OE}	D0-D7	MODE	POWER
H	X	X	X	High Z	Standby	Standby
X	L	X	X	High Z	Standby	Standby
L	H	L	X	Data In	Write	Active -> Standby*
L	H	H	L	Data Out	Read	Active -> Standby*
L	H	H	H	High Z	Active	Standby*

*The device will consume active power in this mode whenever addresses are changed

TABLE 3: Absolute Maximum Ratings*

Item	Symbol	Rating	Unit
Voltage on any pin relative to V_{SS}	$V_{IN,OUT}$	-0.3 to $V_{CC}+0.3$	V
Voltage on V_{CC} Supply Relative to V_{SS}	V_{CC}	-0.3 to 4.0	V
Power Dissipation	P_D	500	mW
Storage Temperature	T_{STG}	-40 to 125	°C
Operating Temperature	T_A	-40 to +85	°C
Soldering Temperature and Time	T_{SOLDER}	260 °C, 10sec(Lead only)	°C

* Stresses greater than those listed above may cause permanent damage to the device. This is a stress rating only and functional operation of the device at these or any other conditions above those indicated in the operating section of this specification is not implied. Exposure to absolute maximum rating conditions for extended periods may affect reliability.

TABLE 4: Operating Characteristics (Over specified Temperature Range)

Item	Symbol	Test Conditions	Min	Typ	Max	Unit
Supply Voltage	V_{CC}		2.3		3.6	V
Data Retention Voltage	V_{DR}	Chip Disabled (Note 3)	1.8		3.6	V
Input High Voltage	V_{IH}		$0.7V_{CC}$		$V_{CC}+0.5$	V
Input Low Voltage	V_{IL}		-0.5		$0.3V_{CC}$	V
Output High Voltage	V_{OH}	$I_{OH} = 0.2mA$	$V_{CC}-0.2$			V
Output Low Voltage	V_{OL}	$I_{OL} = -0.2mA$			0.2	V
Input Leakage Current	I_{LI}	$V_{IN} = 0$ to V_{CC}			0.5	μA
Output Leakage Current	I_{LO}	$\overline{OE} = V_{IH}$ or Chip Disabled			0.5	μA
Read/Write Operating Supply Current @ 1 μS Cycle Time	I_{CC1}	$V_{CC}=3.6V$, $V_{IN}=V_{IH}$ or V_{IL} Chip Enabled, $I_{OL} = 0$			3.0	mA
Read/Write Operating Supply Current @ 70 nS Cycle Time	I_{CC2}	$V_{CC}=3.6V$, $V_{IN}=V_{IH}$ or V_{IL} Chip Enabled, $I_{OL} = 0$			14.0	mA
Read/Write Quiescent Operating Supply Current (Note 1)	I_{CC3}	$V_{IN} = V_{CC}$ or $0V$ Chip Enabled, $I_{OL} = 0$ $f = 0$, $t_A = 85^\circ C$, $V_{CC} = 3.3V$			20	μA
Operating Standby Current (Note 1)	I_{SB1}	$V_{IN} = V_{CC}$ or $0V$ Chip Disabled $t_A = 55^\circ C$, $V_{CC} = 3.3V$			10	μA
Maximum Standby Current (Note 1)	I_{SB2}	$V_{IN} = V_{CC}$ or $0V$ Chip Disabled $t_A = 85^\circ C$, $V_{CC} = 3.3V$			20	μA
Maximum Data Retention Current (Note 1)	I_{DR}	$V_{CC} = 2.0V$, $V_{IN} = V_{CC}$ or 0 Chip Disabled, $t_A = 85^\circ C$			10	μA

Note 1. This device assumes a standby mode if either $\overline{CE1}$ is disabled (high) or $CE2$ is disabled (low). It will also automatically go into a standby mode whenever all input signals are quiescent (not toggling) regardless of the state of $CE1$ or $CE2$. In order to achieve low standby current in the enabled mode ($CE1$ low and $CE2$ high), all inputs must be within 0.2 volts of either V_{CC} or V_{SS} .

TABLE 5: Timing Test Conditions

Item	
Input Pulse Level	0.1V _{CC} to 0.9 V _{CC}
Input Rise and Fall Time	5ns
Input and Output Timing Reference Levels	0.5 V _{CC}
Output Load	CL = 30pF
Operating Temperature	-40 to +85°C

TABLE 6: Timing

Item	Symbol	2.3 - 3.6 V		3.0 - 3.6 V		Units
		Min.	Max.	Min.	Max.	
Read Cycle Time	t _{RC}	70		55		ns
Address Access Time	t _{AA}		70		55	ns
Chip Enable to Valid Output	t _{CO}		70		55	ns
Output Enable to Valid Output	t _{OE}		25		20	ns
Chip Enable to Low-Z output	t _{LZ}	10		10		ns
Output Enable to Low-Z Output	t _{OLZ}	5		5		ns
Chip Disable to High-Z Output	t _{HZ}	0	20	0	15	ns
Output Disable to High-Z Output	t _{OHZ}	0	20	0	15	ns
Output Hold from Address Change	t _{OH}	10		10		ns
Write Cycle Time	t _{WC}	70		55		ns
Chip Enable to End of Write	t _{CW}	50		45		ns
Address Valid to End of Write	t _{AW}	50		45		ns
Write Pulse Width	t _{WP}	40		35		ns
Address Setup Time	t _{AS}	0		0		ns
Write Recovery Time	t _{WR}	0		0		ns
Write to High-Z Output	t _{WHZ}		20		15	ns
Data to Write Time Overlap	t _{DW}	40		35		ns
Data Hold from Write Time	t _{DH}	0		0		ns
End Write to Low-Z Output	t _{OW}	5		5		ns

FIGURE 3: Read Cycle Timing ($\overline{WE} = V_{IH}$)

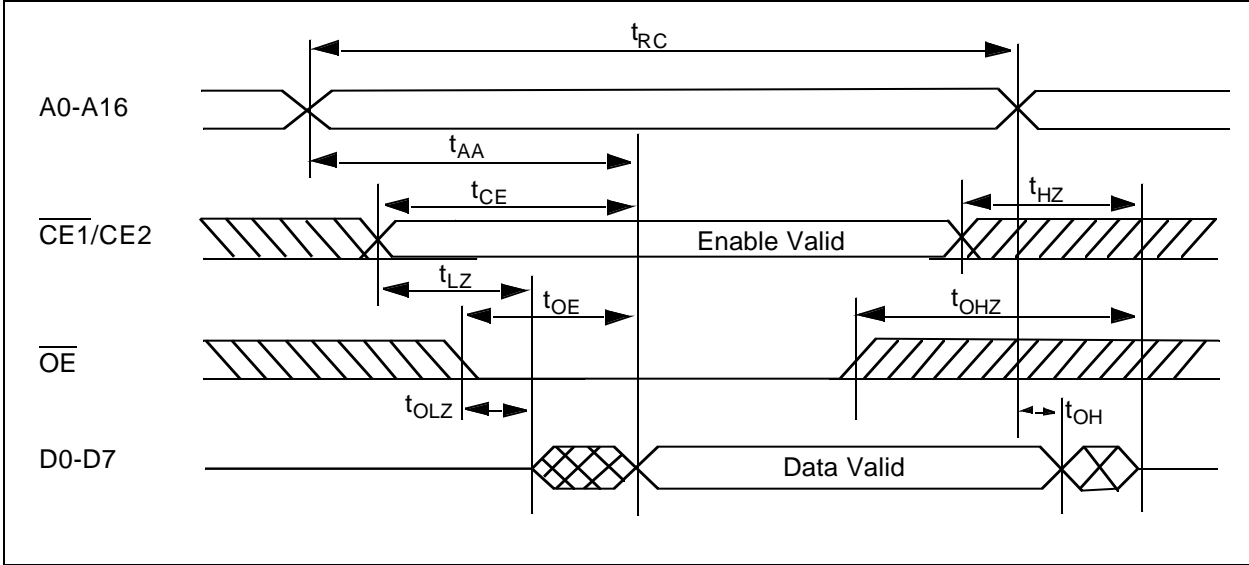

FIGURE 4: Write Cycle Timing (\overline{OE} clock)

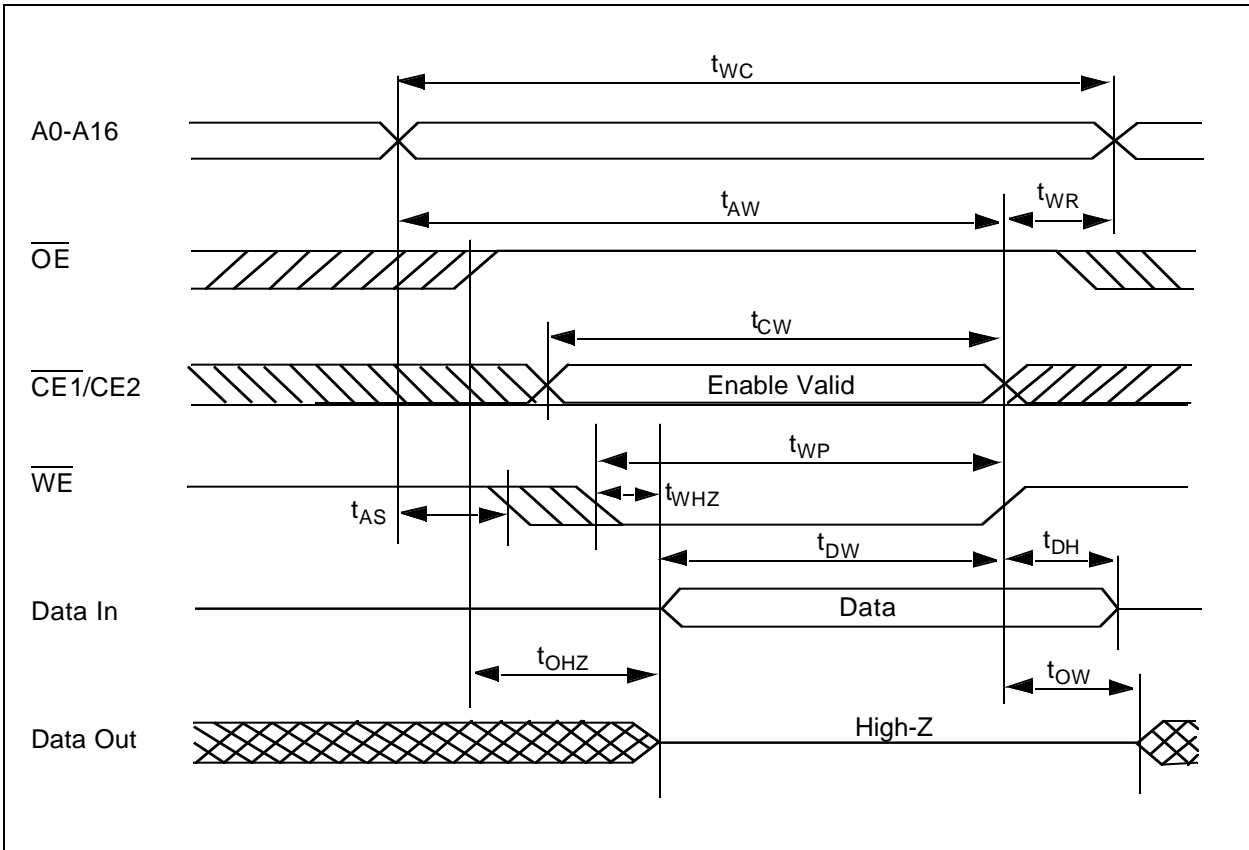

FIGURE 5: Write Cycle Timing (\overline{OE} fixed)

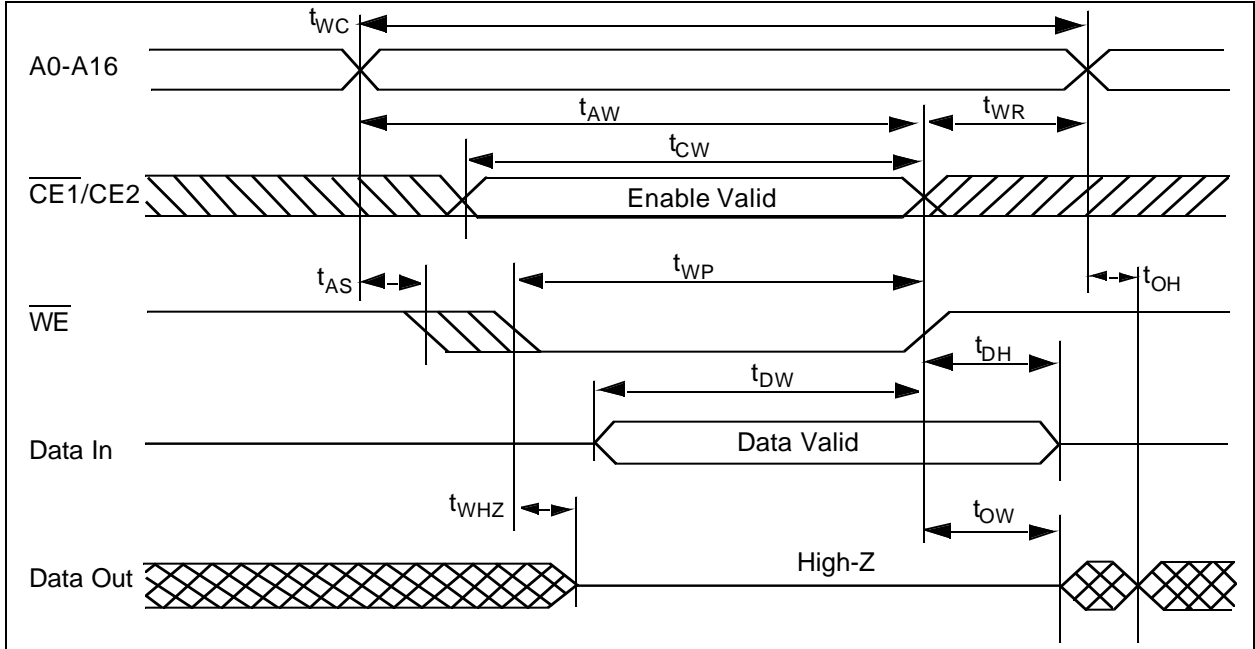

TABLE 7: Ordering Information

Part Number	Package	Temperature Range	Voltage Range	Speed
EM128L08T	32 pin TSOP	-40 to +85°C	2.3 to 3.6 V	55 ns @ 3.0 V
EM128L08N	32 pin STSOP	-40 to +85°C	2.3 to 3.6 V	55 ns @ 3.0 V

TABLE 8: Revision History

Revision #	Date	Change Description
A	Jan. 2001	Initial Advance Release