



## PSD835G2

### Configurable Memory System on a Chip for 8-Bit Microcontrollers

PRELIMINARY DATA

#### FEATURES SUMMARY

- 5 V±10% Single Supply Voltage:
- Up to 4 Mbit of Primary Flash Memory (8 uniform sectors)
- 256Kbit Secondary Flash Memory (4 uniform sectors)
- Up to 64 Kbit SRAM
- Over 3,000 Gates of PLD: DPLD and CPLD
- 52 Reconfigurable I/O ports
- Enhanced JTAG Serial Port
- Programmable power management
- High Endurance:
  - 100,000 Erase/Write Cycles of Flash Memory
  - 1,000 Erase/Write Cycles of PLD

Figure 1. Packages

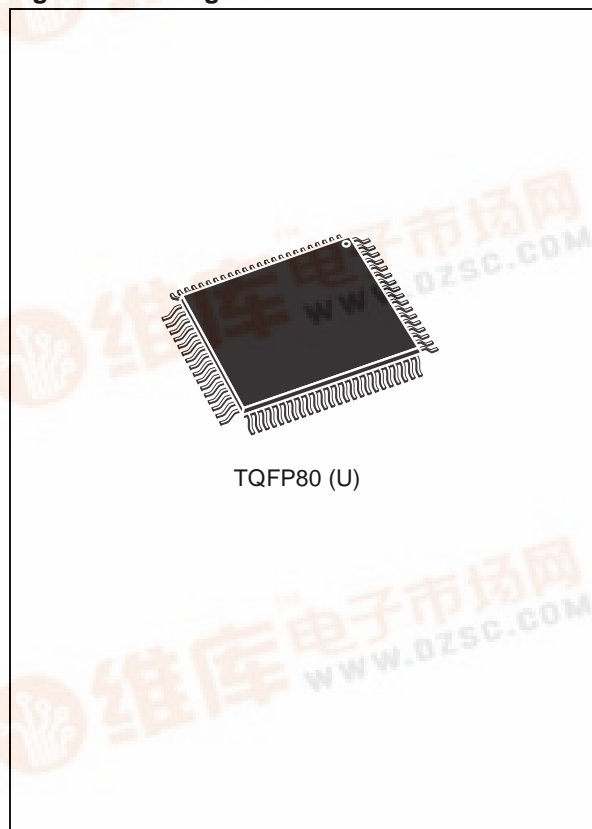



# PSD8XX Family

## PSD835G2

### Configurable Memory System on a Chip for 8-Bit Microcontrollers

#### 1.0 Introduction

The PSD8XX series of Programmable Microcontroller (MCU) Peripherals brings In-System-Programmability (ISP) to Flash memory and programmable logic. The result is a simple and flexible solution for embedded designs. PSD8XX devices combine many of the peripheral functions found in MCU based applications:

- 4 Mbit of Flash memory
- A secondary Flash memory for boot or data
- Over 3,000 gates of Flash programmable logic
- 64 Kbit SRAM
- Reconfigurable I/O ports
- Programmable power management.

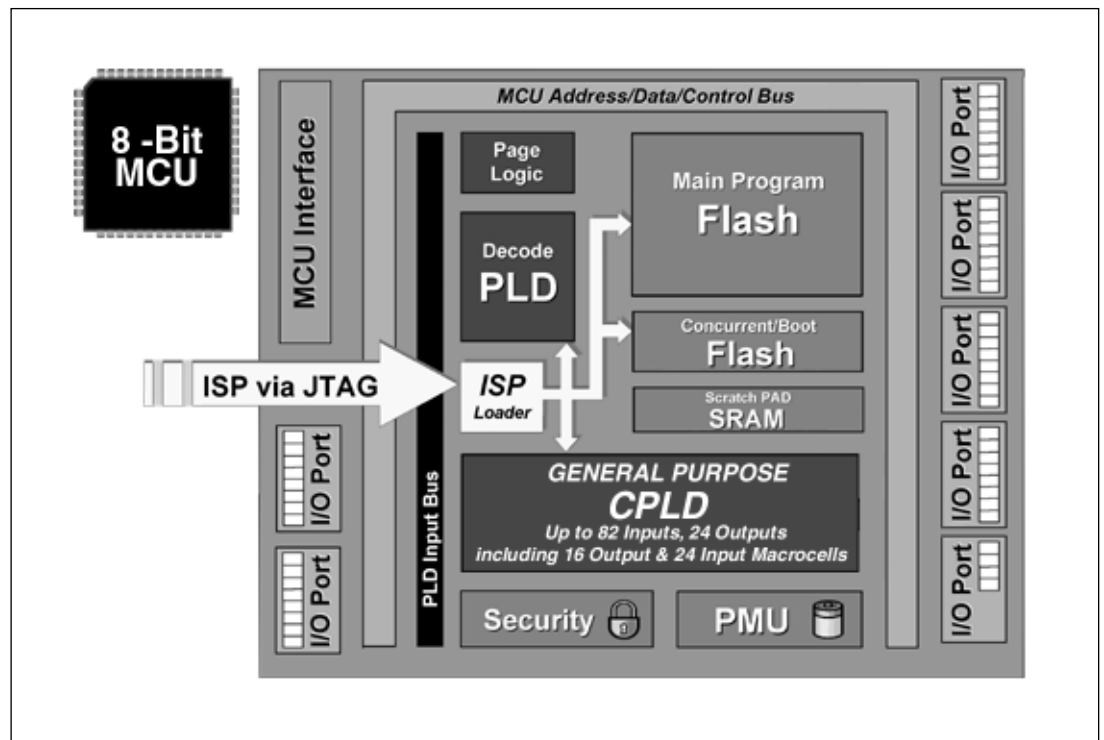

## 1.0 Introduction

(Cont.)

The PSD835G2 device offers two methods to program PSD Flash memory while the PSD is soldered to a circuit board.

In-System Programming (ISP) via JTAG

An IEEE 1149.1 compliant JTAG-ISP interface is included on the PSD enabling the entire device (both flash memories, the PLD, and all configuration) to be rapidly programmed while soldered to the circuit board. This requires no MCU participation, which means the PSD can be programmed anytime, even while completely blank.

The innovative JTAG interface to flash memories is an industry first, solving key problems faced by designers and manufacturing houses, such as:

- **First time programming** – How do I get firmware into the flash the very first time? JTAG is the answer, program the PSD while blank with no MCU involvement.
- **Inventory build-up of pre-programmed devices** – How do I maintain an accurate count of pre-programmed flash memory and PLD devices based on customer demand? How many and what version? JTAG is the answer, build your hardware with blank PSDs soldered directly to the board and then custom program just before they are shipped to customer. No more labels on chips and no more wasted inventory.
- **Expensive sockets** – How do I eliminate the need for expensive and unreliable sockets? JTAG is the answer. Solder the PSD directly to the circuit board. Program first time and subsequent times with JTAG. No need to handle devices and bend the fragile leads.

In-Application re-Programming (IAP)

Two independent flash memory arrays are included so the MCU can execute code from one memory while erasing and programming the other. Robust product firmware updates in the field are possible over any communication channel (CAN, Ethernet, UART, J1850, etc) using this unique architecture. Designers are relieved of these problems:

- **Simultaneous read and write to flash memory** – How can the MCU program the same memory from which it is executing code? It cannot. The PSD allows the MCU to operate the two flash memories concurrently, reading code from one while erasing and programming the other during IAP.
- **Complex memory mapping** – How can I map these two memories efficiently? A Programmable Decode PLD is embedded in the PSD. The concurrent PSD memories can be mapped anywhere in MCU address space, segment by segment with extremely high address resolution. As an option, the secondary flash memory can be swapped out of the system memory map when IAP is complete. A built-in page register breaks the MCU address limit.
- **Separate program and data space** – How can I write to flash memory while it resides in “program” space during field firmware updates, my 80C51 won’t allow it. The flash PSD provides means to “reclassify” flash memory as “data” space during IAP, then back to “program” space when complete.

PSDsoft – ST’s software development tool – guides you through the design process step-by-step making it possible to complete an embedded MCU design capable of ISP/IAP in just hours. Select your MCU and PSDsoft will take you through the remainder of the design with point and click entry, covering...PSD selection, pin definitions, programmable logic inputs and outputs, MCU memory map definition, ANSI C code generation for your MCU, and merging your MCU firmware with the PSD design. When complete, two different device programmers are supported directly from PSDsoft – FlashLINK (JTAG) and PSDpro.

The PSD835G2 is available in an 80-pin TQFP package.

Please refer to the revision block at the end of this document for updated information.

## 2.0 Key Features

- ❑ A simple interface to 8-bit microcontrollers that use either multiplexed or non-multiplexed busses. The bus interface logic uses the control signals generated by the microcontroller automatically when the address is decoded and a read or write is performed. A partial list of the MCU families supported include:
  - Intel 8031, 80196, 80188, 80C251
  - Motorola 68HC11 and 68HC16
  - Philips 8031 and 80C51XA
  - Zilog Z80, Z8 and Z180
  - Infineon C500 family
- ❑ 4 Mbit Flash memory. This is the main Flash memory. It is divided into eight equal-sized blocks that can be accessed with user-specified addresses.
- ❑ Internal secondary 256 Kbit Flash boot memory. It is divided into four equal-sized blocks that can be accessed with user-specified addresses. This secondary memory brings the ability to execute code and update the main Flash **concurrently**.
- ❑ 64 Kbit SRAM. The SRAM's contents can be protected from a power failure by connecting an external battery.
- ❑ CPLD with 16 Output Micro⇌Cells (OMCs) and 24 Input Micro⇌Cells (IMCs). The CPLD may be used to efficiently implement a variety of logic functions for internal and external control. Examples include state machines, loadable shift registers, and loadable counters. The CPLD can also generate eight external chip selects.
- ❑ Decode PLD (DPLD) that decodes address for selection of internal memory blocks.
- ❑ 52 individually configurable I/O port pins that can be used for the following functions:
  - MCU I/Os
  - PLD I/Os
  - Latched MCU address output
  - Special function I/Os.
  - I/O ports may be configured as open-drain outputs.
- ❑ Standby current as low as 50  $\mu$ A for 5 V devices.
- ❑ Built-in JTAG compliant serial port allows full-chip In-System Programmability (ISP). With it, you can program a blank device or reprogram a device in the factory or the field.
- ❑ Internal page register that can be used to expand the microcontroller address space by a factor of 256.
- ❑ Internal programmable Power Management Unit (PMU) that supports a low power mode called Power Down Mode. The PMU can automatically detect a lack of microcontroller activity and put the PSD8XX into Power Down Mode.
- ❑ Erase/Write cycles:
  - Flash memory – 100,000 minimum
  - PLD – 1,000 minimum

## 3.0 PSD8XX Series

Table 1. PSD8XX Product Matrix

Part #	Device	I/O Pins	PLD Inputs	Input Macrocells	Output Macrocells	PLD Outputs	Flash Serial ISP JTAG/ISP Port	Flash Main Memory Kbit 8 Sectors	Boot Memory Kbit (4 Sectors)	SRAM Kbit	Supply Voltage
PSD8XX	PSD835G2	52		24	16	24	Yes	4096	256	64	5V
	PSD813F2	27	57	24	16	19	Yes	1024	256	16	5V
	PSD834F2	27	57	24	16	19	Yes	2048	256	64	5V
	PSD833F2	27	57	24	16	19	Yes	1024	256	64	5V

Figure 1. PSD835G2 Block Diagram

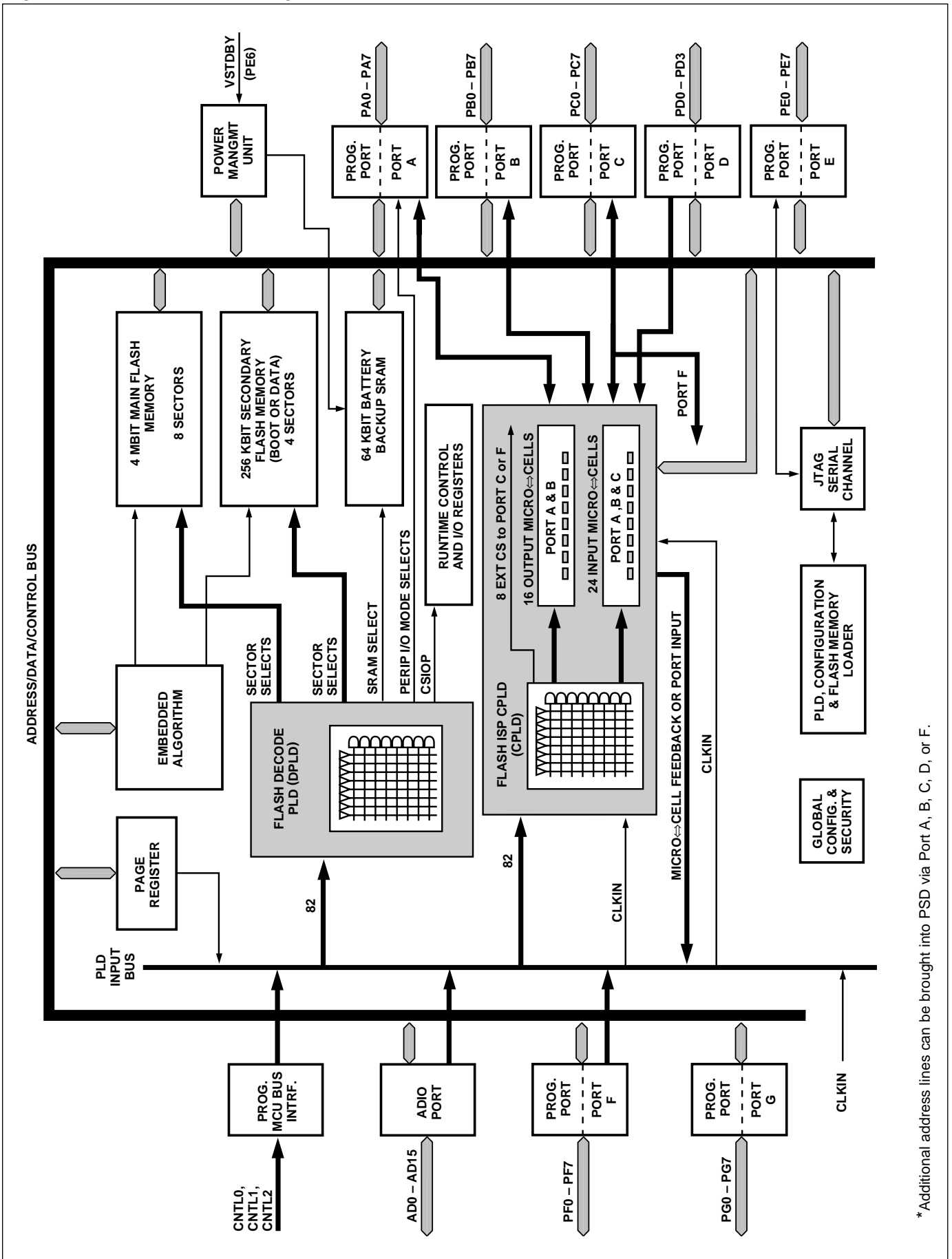

\* Additional address lines can be brought into PSD via Port A, B, C, D, or F.



## 4.0 PSD8XX Architectural Overview

PSD8XX devices contain several major functional blocks. Figure 1 on page 3 shows the architecture of the PSD8XX device family. The functions of each block are described briefly in the following sections. Many of the blocks perform multiple functions and are user configurable.

### 4.1 Memory

The PSD835G2 contains the following memories:

- 4 Mbit Flash
- A secondary 256 Kbit Flash memory for boot or data
- 64 Kbit SRAM.

Each of the memories is briefly discussed in the following paragraphs. A more detailed discussion can be found in section 9.

The 4 Mbit Flash is the main memory of the PSD835G2. It is divided into eight equally-sized sectors that are individually selectable.

The 256 Kbit secondary Flash memory is divided into four equally-sized sectors. Each sector is individually selectable.

The 64 Kbit SRAM is intended for use as a scratchpad memory or as an extension to the microcontroller SRAM. If an external battery is connected to the PSD8XX's Vstby pin, data will be retained in the event of a power failure.

Each block of memory can be located in a different address space as defined by the user. The access times for all memory types includes the address latching and DPLD decoding time.

### 4.2 PLDs

The device contains two PLD blocks, each optimized for a different function, as shown in Table 2. The functional partitioning of the PLDs reduces power consumption, optimizes cost/performance, and eases design entry.

The Decode PLD (DPLD) is used to decode addresses and generate chip selects for the PSD835G2 internal memory and registers. The CPLD can implement user-defined logic functions. The DPLD has combinatorial outputs. The CPLD has 16 Output Micro $\leftrightarrow$ Cells and 8 combinatorial outputs. The PSD835G2 also has 24 Input Micro $\leftrightarrow$ Cells that can be configured as inputs to the PLDs. The PLDs receive their inputs from the PLD Input Bus and are differentiated by their output destinations, number of Product Terms, and Micro $\leftrightarrow$ Cells.

The PLDs consume minimal power by using Zero-Power design techniques. The speed and power consumption of the PLD is controlled by the Turbo Bit in the PMMR0 register and other bits in the PMMR2 registers. These registers are set by the microcontroller at runtime. There is a slight penalty to PLD propagation time when invoking the non-Turbo bit.

### 4.3 I/O Ports

The PSD835G2 has 52 I/O pins divided among seven ports (Port A, B, C, D, E, F and G). Each I/O pin can be individually configured for different functions. Ports can be configured as standard MCU I/O ports, PLD I/O, or latched address outputs for microcontrollers using multiplexed address/data busses.

The JTAG pins can be enabled on Port E for In-System Programming (ISP). Ports F and G can also be configured as a data port for a non-multiplexed bus.

### 4.4 Microcontroller Bus Interface

The PSD835G2 easily interfaces with most 8-bit microcontrollers that have either multiplexed or non-multiplexed address/data busses. The device is configured to respond to the microcontroller's control signals, which are also used as inputs to the PLDs. Section 9.3.5 contains microcontroller interface examples.

Table 2. PLD I/O Table

Name	Abbreviation	Inputs	Outputs	Product Terms
Decode PLD	DPLD	82	17	43
Complex PLD	CPLD	82	24	150

## PSD8XX Architectural Overview (cont.)

### 4.5 ISP via JTAG Port

In-System Programming can be performed through the JTAG pins on Port E. This serial interface allows complete programming of the entire PSD835G2 device. A blank device can be completely programmed. The JTAG signals (TMS, TCK, TSTAT,  $\overline{\text{TERR}}$ , TDI, TDO) can be multiplexed with other functions on Port E. Table 3 indicates the JTAG signals pin assignments.

### 4.6 In-System Programming (ISP)

Using the JTAG signals on Port E, the entire PSD835G2 (memory, logic, configuration) device can be programmed or erased without the use of the microcontroller.

Table 3. JTAG Signals on Port E

Port E Pins	JTAG Signal
PE0	TMS
PE1	TCK
PE2	TDI
PE3	TDO
PE4	TSTAT
PE5	$\overline{\text{TERR}}$

### 4.7 In-Application re-Programming (IAP)

The main Flash memory can also be programmed in-system by the microcontroller executing the programming algorithms out of the secondary Flash memory, or SRAM. Since this is a sizable separate block, the application can also continue to operate. The secondary Flash boot memory can be programmed the same way by executing out of the main Flash memory. Table 4 indicates which programming methods can program different functional blocks of the PSD8XX.

Table 4. Methods of Programming Different Functional Blocks of the PSD835G2

Functional Block	JTAG-ISP	Device Programmer	IAP
Main Flash memory	Yes	Yes	Yes
Flash Boot memory	Yes	Yes	Yes
PLD Array (DPLD and CPLD)	Yes	Yes	No
PSD Configuration	Yes	Yes	No

### 4.8 Page Register

The eight-bit Page Register expands the address range of the microcontroller by up to 256 times. The paged address can be used as part of the address space to access external memory and peripherals or internal memory and I/O. The Page Register can also be used to change the address mapping of blocks of Flash memory into different memory spaces for IAP.

### 4.9 Power Management Unit

The Power Management Unit (PMU) in the PSD835G2 gives the user control of the power consumption on selected functional blocks based on system requirements. The PMU includes an Automatic Power Down unit (APD) that will turn off device functions due to microcontroller inactivity. The APD unit has a Power Down Mode that helps reduce power consumption.

The PSD835G2 also has some bits that are configured at run-time by the MCU to reduce power consumption of the CPLD. The turbo bit in the PMMR0 register can be turned off and the CPLD will latch its outputs and go to standby until the next transition on its inputs. Additionally, bits in the PMMR2 register can be set by the MCU to block signals from entering the CPLD to reduce power consumption. See section 9.5.

## 5.0 Development System

The PSD8XX series is supported by PSDsoft a Windows-based (95, 98, NT) software development tool. A PSD design is quickly and easily produced in a point and click environment. The designer does not need to enter Hardware Definition Language (HDL) equations (unless desired) to define PSD pin functions and memory map information. The general design flow is shown in Figure 2 below. PSDsoft is available from our web site ([www.st.com/psm](http://www.st.com/psm)) or other distribution channels.

PSDsoft directly supports two low cost device programmers from ST. PSDpro and FlashLINK (JTAG). Both of these programmers may be purchased through your local rep/distributor, or directly from our web site using a credit card. The PSD8XX is also supported by third party device programmers, see web site for current list.

Figure 2. PSDsoft Development Tool

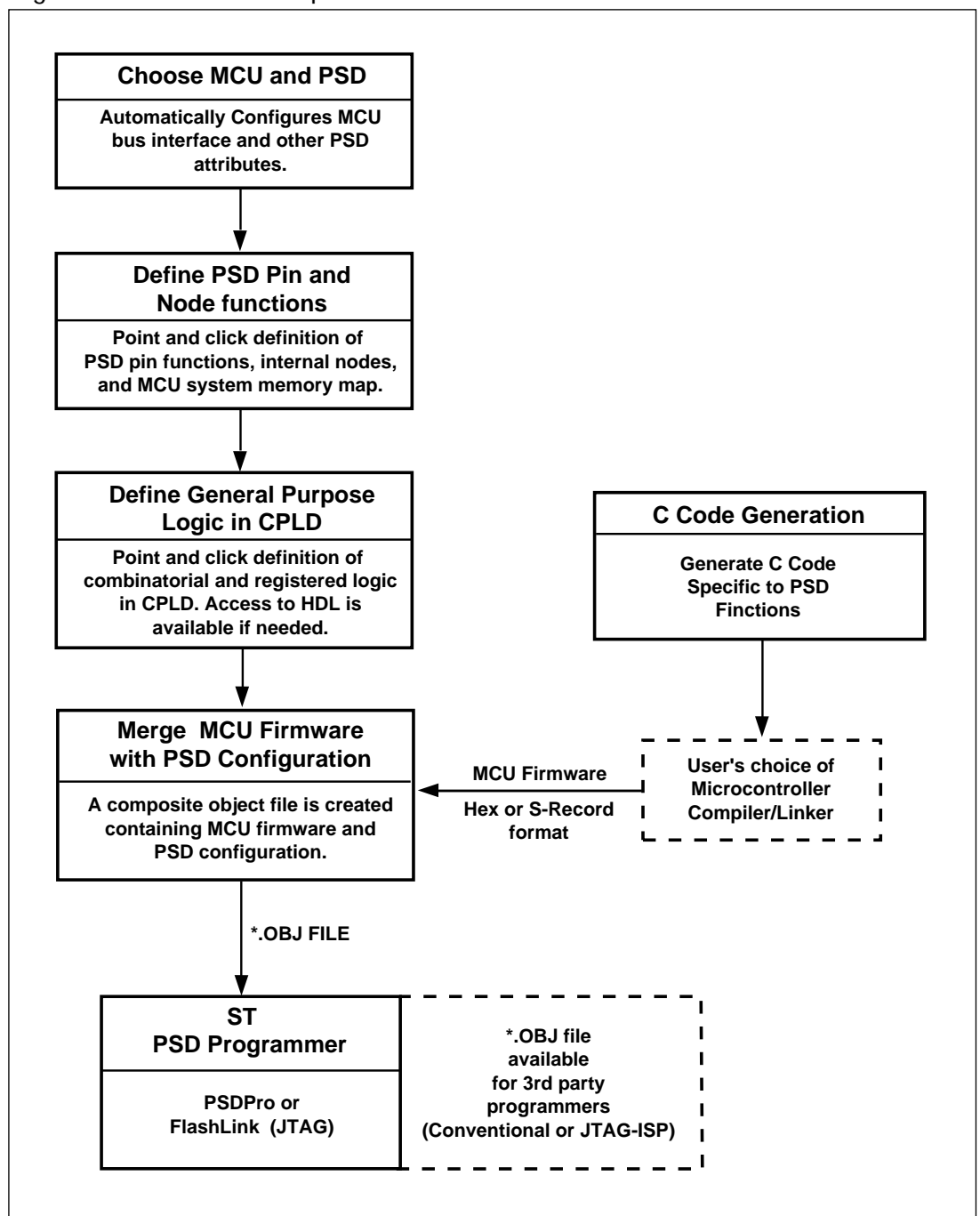

6.0  
Table 5.  
PSD835G2  
Pin  
Descriptions

The following table describes the pin names and pin functions of the PSD835G2. Pins that have multiple names and/or functions are defined using PSDsoft.

Pin Name	Pin* (TQFP Pkg.)	Type	Description
ADIO0-7	3-7 10-12	I/O	This is the lower Address/Data port. Connect your MCU address or address/data bus according to the following rules: 1. If your MCU has a multiplexed address/data bus where the data is multiplexed with the lower address bits, connect AD[0:7] to this port. 2. If your MCU does not have a multiplexed address/data bus, connect A[0:7] to this port. 3. If you are using an 80C51XA in burst mode, connect A4/D0 through A11/D7 to this port. ALE or AS latches the address. The PSD drives data out only if the read signal is active and one of the PSD functional blocks was selected. The addresses on this port are passed to the PLDs.
ADIO8-15	13-20	I/O	This is the upper Address/Data port. Connect your MCU address or address/data bus according to the following rules: 1. If your MCU has a multiplexed address/data bus where the data is multiplexed with the lower address bits, connect A[8:15] to this port. 2. If your MCU does not have a multiplexed address/data bus, connect A[8:15] to this port. 3. If you are using an 80C251 in page mode, connect AD[8:15] to this port 4. If you are using an 80C51XA in burst mode, connect A[12:19] to this port. ALE or AS latches the address. The PSD drives data out only if the read signal is active and one of the PSD functional blocks was selected. The addresses on this port are passed to the PLDs.
CNTL0	59	I	The following control signals can be connected to this port, based on your MCU: 1. $\overline{WR}$ — active-low write input. 2. $\overline{R\_W}$ — active-high read/active low write input. This pin is connected to the PLDs. Therefore, these signals can be used in decode and other logic equations.
CNTL1	60	I	The following control signals can be connected to this port, based on your MCU: 1. $\overline{RD}$ — active-low read input. 2. $\overline{E}$ — E clock input. 3. $\overline{DS}$ — active-low data strobe input. 4. $\overline{PSEN}$ — connect $\overline{PSEN}$ to this port when it is being used as an active-low read signal. For example, when the 80C251 outputs more than 16 address bits, $\overline{PSEN}$ is actually the read signal. This pin is connected to the PLDs. Therefore, these signals can be used in decode and other logic equations.
CNTL2	40	I	This pin can be used to input the $\overline{PSEN}$ (Program Select Enable) signal from any MCU that uses this signal for code exclusively. If your MCU does not output a Program Select Enable signal, this port can be used as a generic input. This port is connected to the PLD as input.
$\overline{Reset}$	39	I	Active low input. Resets I/O Ports, PLD Micro $\leftrightarrow$ Cells, some of the configuration registers and JTAG registers. Must be active at power up. Reset also aborts the Flash programming/erase cycle that is in progress.

Table 5.  
PSD835G2  
Pin  
Descriptions  
(cont.)

Pin Name	Pin* (TQFP Pkg.)	Type	Description
PA0-PA7	51-58	I/O CMOS or Open Drain	Port A, PA0-7. This port is pin configurable and has multiple functions: 1. MCU I/O — standard output or input port 2. CPLD Micro $\leftrightarrow$ Cell (MCell A0-7) output. 3. Latched, transparent or registered PLD input.
PB0-PB7	61-68	I/O CMOS or Open Drain	Port B, PB0-7. This port is pin configurable and has multiple functions: 1. MCU I/O — standard output or input port. 2. CPLD Micro $\leftrightarrow$ Cell (MCell B0-7) output. 3. Latched, transparent or registered PLD input.
PC0-PC7	41-48	I/O CMOS or Slew Rate	Port C, PC0-7. This port is pin configurable and has multiple functions: 1. MCU I/O — standard output or input port. 2. External chip select (ECS0-7) output. 3. Latched, transparent or registered PLD input.
PD0	79	I/O CMOS or Open Drain	Port D pin PD0 can be configured as: 1. $\overline{ALE}$ or AS input — latches addresses on ADIO0-15 pins 2. $\overline{AS}$ input — latches addresses on ADIO0-15 pins on the rising edge. 3. Input to the PLD. 4. Transparent PLD input.
PD1	80	I/O CMOS or Open Drain	Port D pin PD1 can be configured as: 1. MCU I/O 2. Input to the PLD. 3. CLKIN clock input — clock input to the CPLD Micro $\leftrightarrow$ Cells, the APD power down counter and CPLD AND Array.
PD2	1	I/O CMOS or Open Drain	Port D pin PD2 can be configured as: 1. MCU I/O 2. Input to the PLD. 3. $\overline{CSI}$ input — chip select input. When low, the $\overline{CSI}$ enables the internal PSD memories and I/O. When high, the internal memories are disabled to conserve power. $\overline{CSI}$ trailing edge can get the part out of power-down mode.
PD3	2	I/O CMOS or Open Drain	Port D pin PD3 can be configured as: 1. MCU I/O 2. Input to the PLD.
PE0	71	I/O CMOS or Open Drain	Port E, PE0. This port is pin configurable and has multiple functions: 1. MCU I/O — standard output or input port. 2. Latched address output. 3. TMS input for JTAG/ISP interface.
PE1	72	I/O CMOS or Open Drain	Port E, PE1. This port is pin configurable and has multiple functions: 1. MCU I/O — standard output or input port. 2. Latched address output. 3. TCK input for JTAG/ISP interface (Schmidt Trigger).
PE2	73	I/O CMOS or Open Drain	Port E, PE2. This port is pin configurable and has multiple functions: 1. MCU I/O — standard output or input port. 2. Latched address output. 3. TDI input for JTAG/ISP interface.

Table 5.  
PSD835G2  
Pin  
Descriptions  
(cont.)

Pin Name	Pin* (TQFP Pkg.)	Type	Description
PE3	74	I/O CMOS or Open Drain	Port E, PE3. This port is pin configurable and has multiple functions: 1. MCU I/O — standard output or input port. 2. Latched address output. 3. TDO output for JTAG/ISP interface.
PE4	75	I/O CMOS or Open Drain	Port E, PE4. This port is pin configurable and has multiple functions: 1. MCU I/O — standard output or input port. 2. Latched address output. 3. TSTAT output for the ISP interface. 4. Rdy/Bsy — for in-circuit Parallel Programming.
PE5	76	I/O CMOS or Open Drain	Port E, PE5. This port is pin configurable and has multiple functions: 1. MCU I/O — standard output or input port. 2. Latched address output. 3. TERR active low output for ISP interface.
PE6	77	I/O CMOS or Open Drain	Port E, PE6. This port is pin configurable and has multiple functions: 1. MCU I/O — standard output or input port. 2. Latched address output. 3. Vstby — SRAM standby voltage input for battery backup SRAM
PE7	78	I/O CMOS or Open Drain	Port E, PE7. This port is pin configurable and has multiple functions: 1. MCU I/O — standard output or input port. 2. Latched address output. 3. Vbaton — battery backup indicator output. Goes high when power is drawn from an external battery.
PF0-PF7	31-38	I/O CMOS or Open Drain	Port F, PF0-7. This port is pin configurable and has multiple functions: 1. MCU I/O — standard output or input port. 2. Input to the PLD. 3. Latched address outputs. 4. As address A0-3 inputs in 80C51XA mode 5. As data bus port (D0-7) in non-multiplexed bus configuration
PG0-PG7	21-28	I/O CMOS or Open Drain	Port G, PG0-7. This port is pin configurable and has multiple functions: 1. MCU I/O — standard output or input port. 2. Latched address outputs.
GND	8,30, 49,50, 70		
V <sub>CC</sub>	9,29, 69		

## 7.0 PSD835G2 Register Description and Address Offset

Table 6 shows the offset addresses to the PSD835G2 registers relative to the CSIOP base address. The CSIOP space is the 256 bytes of address that is allocated by the user to the internal PSD835G2 registers. Table 6 provides brief descriptions of the registers in CSIOP space. For a more detailed description, refer to section 9.

Table 6. Register Address Offset

Register Name	Port A	Port B	Port C	Port D	Port E	Port F	Port G	Other *	Description
Data In	00	01	10	11	30	40	41		Reads Port pin as input, MCU I/O input mode
Control					32	42	43		Selects mode between MCU I/O or Address Out
Data Out	04	05	14	15	34	44	45		Stores data for output to Port pins, MCU I/O output mode
Direction	06	07	16	17	36	46	47		Configures Port pin as input or output
Drive Select	08	09	18	19	38	48	49		Configures Port pins as either CMOS or Open Drain on some pins, while selecting high slew rate on other pins.
Input Micro↔Cell	0A	0B		1A					Reads Input Micro↔Cells
Enable Out	0C	0D	1C			4C			Reads the status of the output enable to the I/O Port driver
Output Micro↔Cells A	20								Read – reads output of Micro↔Cells A Write – loads Micro↔cell Flip-Flops
Output Micro↔Cells B		21							Read – reads output of Micro↔Cells B Write – loads Micro↔cell Flip-Flops
Mask Micro↔Cells A	22								Blocks writing to the Output Micro↔Cells A
Mask Micro↔Cells B		23							Blocks writing to the Output Micro↔Cells B
Flash Protection								C0	Read only – Flash Sector Protection
Flash Boot Protection								C2	Read only – PSD Security and Flash Boot Sector Protection
JTAG Enable								C7	Enables JTAG Port
PMMR0								B0	Power Management Register 0
PMMR2								B4	Power Management Register 2
Page								E0	Page Register
VM								E2	Places PSD memory areas in Program and/or Data space on an individual basis.
Memory_ID0								F0	Read only – Flash and SRAM size
Memory_ID1								F1	Read only – Boot type and size

## 8.0 Register Bit Definition

All the registers in the PSD835G2 are included here for reference. Detail description of the registers are found in the Functional Block section of the Data Sheet.

Data In Registers – Port A, B, C, D, E, F and G

Bit 7	Bit 6	Bit 5	Bit 4	Bit 3	Bit 2	Bit 1	Bit 0
Port Pin 7	Port Pin 6	Port Pin 5	Port Pin 4	Port Pin 3	Port Pin 2	Port Pin 1	Port Pin 0

**Bit definitions:**

Read only registers, read Port pin status when Port is in MCU I/O input Mode.

Data Out Registers – Port A, B, C, D, E, F and G

Bit 7	Bit 6	Bit 5	Bit 4	Bit 3	Bit 2	Bit 1	Bit 0
Port Pin 7	Port Pin 6	Port Pin 5	Port Pin 4	Port Pin 3	Port Pin 2	Port Pin 1	Port Pin 0

**Bit definitions:**

Latched data for output to Port pin when pin is configured in MCU I/O output mode.

Direction Registers – Port A, B, C, D, E, F and G

Bit 7	Bit 6	Bit 5	Bit 4	Bit 3	Bit 2	Bit 1	Bit 0
Port Pin 7	Port Pin 6	Port Pin 5	Port Pin 4	Port Pin 3	Port Pin 2	Port Pin 1	Port Pin 0

**Bit definitions:**

Set Register Bit to 0 = configure corresponding Port pin in Input mode (default).

Set Register Bit to 1 = configure corresponding Port pin in Output mode.

Control Registers – Ports E, F and G

Bit 7	Bit 6	Bit 5	Bit 4	Bit 3	Bit 2	Bit 1	Bit 0
Port Pin 7	Port Pin 6	Port Pin 5	Port Pin 4	Port Pin 3	Port Pin 2	Port Pin 1	Port Pin 0

**Bit definitions:**

Set Register Bit to 0 = configure corresponding Port pin in MCU I/O mode (default).

Set Register Bit to 1 = configure corresponding Port pin in Latched Address Out mode.

Drive Registers – Ports A, B, D, E, and G

Bit 7	Bit 6	Bit 5	Bit 4	Bit 3	Bit 2	Bit 1	Bit 0
Port Pin 7	Port Pin 6	Port Pin 5	Port Pin 4	Port Pin 3	Port Pin 2	Port Pin 1	Port Pin 0

**Bit definitions:**

Set Register Bit to 0 = configure corresponding Port pin in CMOS output driver (default).

Set Register Bit to 1 = configure corresponding Port pin in Open Drain output driver.

Drive Registers – Ports C and F

Bit 7	Bit 6	Bit 5	Bit 4	Bit 3	Bit 2	Bit 1	Bit 0
Port Pin 7	Port Pin 6	Port Pin 5	Port Pin 4	Port Pin 3	Port Pin 2	Port Pin 1	Port Pin 0

**Bit definitions:**

Set Register Bit to 0 = configure corresponding Port pin as CMOS output driver (default).

Set Register Bit to 1 = configure corresponding Port pin in Slew Rate mode.

Enable Out Registers – Ports A, B, C and F

Bit 7	Bit 6	Bit 5	Bit 4	Bit 3	Bit 2	Bit 1	Bit 0
Port Pin 7	Port Pin 6	Port Pin 5	Port Pin 4	Port Pin 3	Port Pin 2	Port Pin 1	Port Pin 0

**Bit definitions: Read Only Registers**

Register Bit <j> = 0 indicates Port pin driver is in tri-state mode (default).

Register Bit <j> = 1 indicates Port pin driver is enabled.

## 8.0 Register Bit Definition (cont.)

### Input Micro↔Cells – Ports A, B and C

Bit 7	Bit 6	Bit 5	Bit 4	Bit 3	Bit 2	Bit 1	Bit 0
IMcell7	IMcell6	IMcell5	IMcell4	IMcell3	IMcell2	IMcell1	IMcell0

#### Bit definitions: Read Only Registers

Read Input Micro↔Cell[7:0] status on Ports A, B and C.

### Output Micro↔Cells A Register

Bit 7	Bit 6	Bit 5	Bit 4	Bit 3	Bit 2	Bit 1	Bit 0
Mcella7	Mcella6	Mcella5	Mcella4	Mcella3	Mcella2	Mcella1	Mcella0

#### Bit definitions:

**Write Register:** Load Micro↔CellA[7:0] with 0 or 1.

**Read Register:** Read Micro↔CellA[7:0] output status.

### Output Micro↔Cells B Register

Bit 7	Bit 6	Bit 5	Bit 4	Bit 3	Bit 2	Bit 1	Bit 0
Mcellb7	Mcellb6	Mcellb5	Mcellb4	Mcellb3	Mcellb2	Mcellb1	Mcellb0

#### Bit definitions:

**Write Register:** Load Micro↔CellB[7:0] with 0 or 1.

**Read Register:** Read Micro↔CellB[7:0] output status.

### Mask Micro↔Cells A Register

Bit 7	Bit 6	Bit 5	Bit 4	Bit 3	Bit 2	Bit 1	Bit 0
Mcella7	Mcella6	Mcella5	Mcella4	Mcella3	Mcella2	Mcella1	Mcella0

#### Bit definitions:

Register Bit <j> to 0 = allow Micro↔CellA<j> flip flop to be loaded by MCU (default).

Register Bit <j> to 1 = does not allow Micro↔CellA<j> flip flop to be loaded by MCU.

### Mask Micro↔Cells B Register

Bit 7	Bit 6	Bit 5	Bit 4	Bit 3	Bit 2	Bit 1	Bit 0
Mcellb7	Mcellb6	Mcellb5	Mcellb4	Mcellb3	Mcellb2	Mcellb1	Mcellb0

#### Bit definitions:

Register Bit <j> to 0 = allow Micro↔CellB<j> flip flop to be loaded by MCU (default).

Register Bit <j> to 1 = does not allow Micro↔CellB<j> flip flop to be loaded by MCU.

### Flash Protection Register

Bit 7	Bit 6	Bit 5	Bit 4	Bit 3	Bit 2	Bit 1	Bit 0
Sec7_Prot	Sec6_Prot	Sec5_Prot	Sec4_Prot	Sec3_Prot	Sec2_Prot	Sec1_Prot	Sec0_Prot

#### Bit definitions: Read Only Register

Sec<i>\_Prot 1 = Flash Sector <i> is write protected.

Sec<i>\_Prot 0 = Flash Sector <i> is not write protected.

### Flash Boot Protection Register

Bit 7	Bit 6	Bit 5	Bit 4	Bit 3	Bit 2	Bit 1	Bit 0
Security_Bit	*	*	*	Sec3_Prot	Sec2_Prot	Sec1_Prot	Sec0_Prot

#### Bit definitions:

Sec<i>\_Prot 1 = Boot Block Sector <i> is write protected.

Sec<i>\_Prot 0 = Boot Block Sector <i> is not write protected.

Security\_Bit 0 = Security Bit in device has not been set.

1 = Security Bit in device has been set.

## 8.0 Register Bit Definition (cont.)

### JTAG Enable Register

Bit 7	Bit 6	Bit 5	Bit 4	Bit 3	Bit 2	Bit 1	Bit 0
*	*	*	*	*	*	*	JTAG_Enable

#### Bit definitions:

JTAG\_Enable 1 = JTAG Port is Enabled.  
0 = JTAG Port is Disabled.

### Page Register

Bit 7	Bit 6	Bit 5	Bit 4	Bit 3	Bit 2	Bit 1	Bit 0
Pgr7	Pgr6	Pgr5	Pgr4	Pgr3	Pgr2	Pgr1	Pgr0

#### Bit definitions:

Configure Page input to PLD. Default Pgr[7:0] = 00.

### PMMR0 Register

Bit 7	Bit 6	Bit 5	Bit 4	Bit 3	Bit 2	Bit 1	Bit 0
*	*	PLD Mcells clk	PLD array-clk	PLD Turbo	*	APD enable	*

\*Not used bit should be set to zero.

#### Bit definitions: (default is 0)

Bit 1 0 = Automatic Power Down (APD) is disabled.  
1 = Automatic Power Down (APD) is enabled.

Bit 3 0 = PLD Turbo is on.  
1 = PLD Turbo is off, saving power.

Bit 4 0 = CLKIN input to the PLD AND array is connected.  
Every CLKIN change will power up the ZPLD when Turbo bit is off.  
1 = CLKIN input to PLD AND array is disconnected, saving power.

Bit 5 0 = CLKIN input to the PLD Micro↔Cells is connected.  
1 = CLKIN input to the PLD Micro↔Cells is disconnected, saving power.

### PMMR1 Register

Bit 7	Bit 6	Bit 5	Bit 4	Bit 3	Bit 2	Bit 1	Bit 0
*	PLD array WRh	PLD array Ale	PLD array Cntl2	PLD array Cntl1	PLD array Cntl0	*	*

\*Not used bit should be set to zero.

#### Bit definitions (default is 0):

Bit 0 0 = Address A[7:0] are connected into the PLD array.  
1 = Address A[7:0] are blocked from the PLD array, saving power.  
Note: in XA mode, A3-0 come from PF3-0 and A7-4 come from ADIO7-4.

Bit 2 0 = Cntl0 input to the PLD AND array is connected.  
1 = Cntl0 input to the PLD AND array is disconnected, saving power.

Bit 3 0 = Cntl1 input to the PLD AND array is connected.  
1 = Cntl1 input to the PLD AND array is disconnected, saving power.

Bit 4 0 = Cntl2 input to the PLD AND array is connected.  
1 = Cntl2 input to the PLD AND array is disconnected, saving power.

Bit 5 0 = Ale input to the PLD AND array is connected.  
1 = Ale input to the PLD AND array is disconnected, saving power.

Bit 6 0 = WRh/DBE input to the PLD AND array is connected.  
1 = WRh/DBE input to the PLD AND array is disconnected, saving power.

## 8.0 Register Bit Definition (cont.)

### VM Register

Bit 7	Bit 6	Bit 5	Bit 4	Bit 3	Bit 2	Bit 1	Bit 0
Periph-mode	*	*	FL_data	Boot_data	FL_code	Boot_code	SR_code

**Note:** Upon reset, Bit1-Bit4 are loaded to configurations selected by the user in PSDsoft. Bit 0 and Bit 7 are always cleared by reset. Bit 0 to Bit 4 are active only when the device is configured in Philips 80C51XA mode.

\* Not used bit should be set to zero

#### Bit definitions:

Bit 0 0 =  $\overline{\text{PSEN}}$  can't access SRAM in 80C51XA modes.  
1 =  $\overline{\text{PSEN}}$  can access SRAM in 80C51XA modes.

Bit 1 0 =  $\overline{\text{PSEN}}$  can't access Boot in 80C51XA modes.  
1 =  $\overline{\text{PSEN}}$  can access Boot in 80C51XA modes.

Bit 2 0 =  $\overline{\text{PSEN}}$  can't access main Flash in 80C51XA modes.  
1 =  $\overline{\text{PSEN}}$  can access main Flash in 80C51XA modes.

Bit 3 0 =  $\overline{\text{RD}}$  can't access Boot in 80C51XA modes.  
1 =  $\overline{\text{RD}}$  can access Boot in 80C51XA modes.

Bit 4 0 =  $\overline{\text{RD}}$  can't access main Flash in 80C51XA modes.  
1 =  $\overline{\text{RD}}$  can access main Flash in 80C51XA modes.

Bit 7 0 = Peripheral mode of Port F is disabled.  
1 = Peripheral mode of Port F is enabled.

### Memory\_ID0 Register

Bit 7	Bit 6	Bit 5	Bit 4	Bit 3	Bit 2	Bit 1	Bit 0
S_size 3	S_size 2	S_size 1	S_size 0	F_size 3	F_size 2	F_size 1	F_size 0

#### Bit definitions:

F\_size[3:0] = 4h, main Flash size is 2M bit.

F\_size[3:0] = 5h, main Flash size is 8M bit.

S\_size[3:0] = 0h, SRAM size is 0K bit.

S\_size[3:0] = 1h, SRAM size is 16K bit.

S\_size[3:0] = 3h, SRAM size is 64K bit.

### Memory\_ID1 Register

Bit 7	Bit 6	Bit 5	Bit 4	Bit 3	Bit 2	Bit 1	Bit 0
*	*	B_type 1	B_type 0	B_size 3	B_size 2	B_size 1	B_size 0

\*Not used bit should be set to zero.

#### Bit definitions:

B\_size[3:0] = 0h, Boot block size is 0K bit.

B\_size[3:0] = 2h, Boot block size is 256K bit.

B\_type[1:0] = 0h, Boot block is Flash memory.

## 9.0 The PSD835G2 Functional Blocks

As shown in Figure 1, the PSD835G2 consists of six major types of functional blocks:

- Memory Blocks
- PLD Blocks
- Bus Interface
- I/O Ports
- Power Management Unit
- JTAG-ISP Interface

The functions of each block are described in the following sections. Many of the blocks perform multiple functions, and are user configurable.

### 9.1 Memory Blocks

The PSD835G2 has the following memory blocks:

- The main Flash memory
- Secondary Flash memory
- SRAM.

The memory select signals for these blocks originate from the Decode PLD (DPLD) and are user-defined in PSDsoft.

Table 7 summarizes which versions of the PSD835G2 contain which memory blocks.

Table 7. Memory Blocks

Device	Main Flash		Secondary Flash		SRAM
	Flash Size	Sector Size	Block Size	Sector Size	
PSD835G2	512KB	64KB	32KB	8KB	8KB

#### 9.1.1 Main Flash and Secondary Flash Memory Description

The main Flash memory block is divided evenly into eight sectors. The secondary Flash memory is divided into four sectors of eight Kbytes each. Each sector of either memory can be separately protected from program and erase operations.

Flash memory may be erased on a sector-by-sector basis and programmed word-by-word. Flash sector erasure may be suspended while data is read from other sectors of memory and then resumed after reading.

During a program or erase of Flash, the status can be output on the Rdy/Bsy pin of Port PE4. This pin is set up using PSDsoft.

##### 9.1.1.1 Memory Block Selects

The decode PLD in the PSD835G2 generates the chip selects for all the internal memory blocks (refer to the PLD section). Each of the eight Flash memory sectors have a Flash Select signal (FS0-FS7) which can contain up to three product terms. Each of the four Secondary Flash memory sectors have a Select signal (CSBOOT0-3) which can contain up to three product terms. Having three product terms for each sector select signal allows a given sector to be mapped in different areas of system memory. When using a microcontroller (80C51) with separate Program and Data space, these flexible select signals allow dynamic re-mapping of sectors from one space to the other before and after IAP.

## The PSD835G2 Functional Blocks (cont.)

### 9.1.1.2 Upper and Lower Block IN MAIN FLASH SECTOR

The PSD835G2's main Flash has eight 64K bytes sector. The 64K byte sector size may cause some difficulty in code mapping for an 8-bit MCU with only 64K byte address space. To resolve this mapping issue, the PSD835G2 provides additional logic (Figure 3) for the user to split the 8 sectors such that each sector has a lower and upper 32K byte block, and the two blocks can reside in different pages but in the same address range.

If your design works with 64KB sectors, you don't need to configure this logic. If the design requires 32KB blocks in each sector, you need to define a "FA15" PLD equation in PSDsoft as the A15 address input to the main Flash module. FA15 consists of 3 product terms and will control whether the MCU is accessing the lower or upper 32KB in the selected sector. Below is an example for Flash sector chip select FS0. A typical equation is FA15 = pgr4 of the Page Register. When pgr4 is 0 (page 00), the lower 32KB is selected. When pgr4 is switched to 1 by the user, the upper 32KB is selected. PSDsoft will automatically generate the PLD equations shown, based on your point and click selections.

page = [pgr7...pgr0]; "Page Register output  
"Sector Chip Select Equation

FS0 = ((0000h <= address <= 7FFFh) & page = 00h) # "select first 32KB block  
(0000h <= address <= 7FFFh) & page = 10h); "select second 32KB block

FA15 = pgr4; "as address A15 input to the main Flash

If no FA15 equation is defined in PSDsoft, the A15 that comes from the MCU address bus will be routed as input to the main Flash instead of FA15. The FA15 equation has no impact in the Sector Erase operation. Note: FA15 affects all eight sectors of the main Flash simultaneously, you cannot direct FA15 to a particular Flash sector only.

### 9.1.1.3 The Ready/Busy Pin (PE4)

Pin PE4 can be used to output the Ready/Busy status of the PSD835G2. The output on the pin will be a '0' (Busy) when Flash memory blocks are being written to, or when the Flash memory block is being erased. The output will be a '1' (Ready) when no write or erase operation is in progress.

Figure 3. Selecting the Upper or Lower Block in a Main Flash Sector

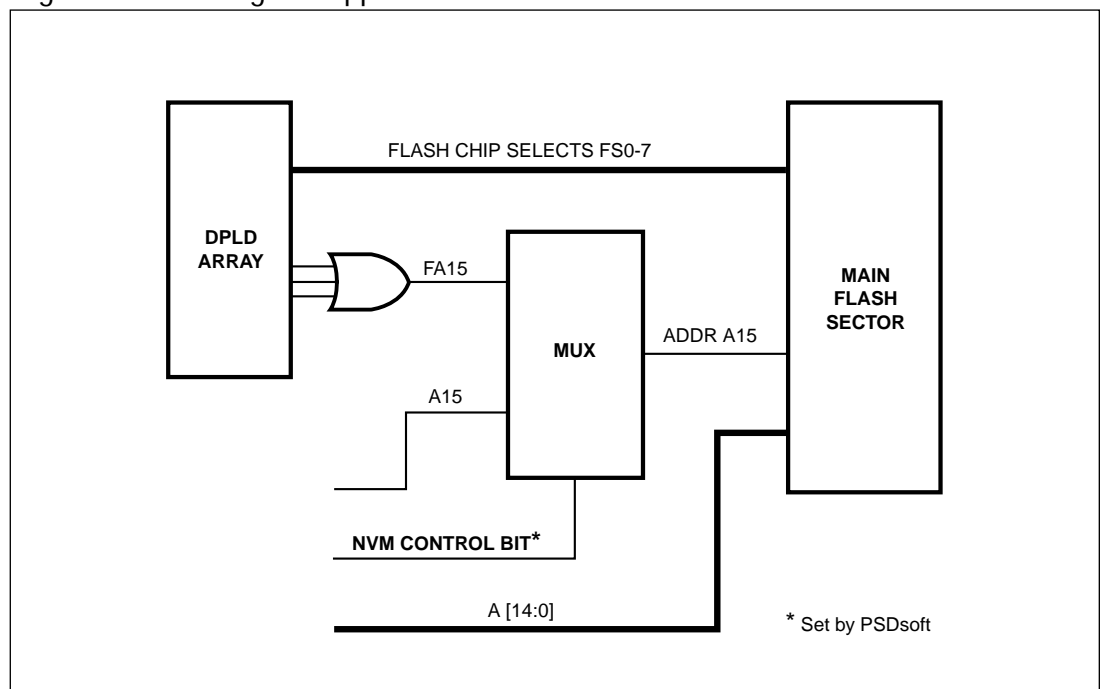

## The PSD835G2 Functional Blocks (cont.)

### 9.1.1.4 Memory Operation

The main Flash and secondary Flash memories are addressed through the microcontroller interface on the PSD835G2 device. The microcontroller can access these memories in one of two ways:

- The microcontroller can execute a typical bus write or read **operation** just as it would if accessing a RAM or ROM device using standard bus cycles.
- The microcontroller can execute a specific **instruction** that consists of several write and read operations. This involves writing specific data patterns to special addresses within the Flash to invoke an embedded algorithm. These instructions are summarized in Table 8.

Typically, Flash memory can be read by the microcontroller using read operations, just as it would read a ROM device. However, Flash memory can only be erased and programmed with specific instructions. For example, the microcontroller cannot write a single byte directly to Flash memory as one would write a byte to RAM. To program a byte into Flash memory, the microcontroller must execute a program instruction sequence, then test the status of the programming event. This status test is achieved by a read operation or polling the Rdy/Busy pin (PE4).

The Flash memory can also be read by using special instructions to retrieve particular Flash device information (sector protect status and ID).

#### 9.1.1.4.1 Instructions

An instruction is defined as a sequence of specific operations. Each received byte is sequentially decoded by the PSD and not executed as a standard write operation. The instruction is executed when the correct number of bytes are properly received and the time between two consecutive bytes is shorter than the time-out value. Some instructions are structured to include read operations after the initial write operations.

The sequencing of any instruction must be followed exactly. Any invalid combination of instruction bytes or time-out between two consecutive bytes while addressing Flash memory will reset the device logic into a read array mode (Flash memory reads like a ROM device).

The PSD835G2 main Flash and secondary Flash support these instructions (see Table 8):

- Erase memory by chip or sector
- Suspend or resume sector erase
- Program a byte
- Reset to read array mode
- Read Main Flash Identifier value
- Read sector protection status
- Bypass Instruction

These instructions are detailed in Table 8. For efficient decoding of the instructions, the first two bytes of an instruction are the coded cycles and are followed by a command byte or confirmation byte. The coded cycles consist of writing the data AAh to address X555h during the first cycle and data 55h to address XAAAh during the second cycle (unless the Bypass Instruction feature is used. See 9.1.1.7). Address lines A15-A12 are don't care during the instruction write cycles. However, the appropriate sector select signal (FSi or CSBOOTi) must be selected.

The main Flash and the secondary Flash Block have the same set of instructions (except Read main Flash ID). The chip selects of the Flash memory will determine which Flash will receive and execute the instruction. The main Flash is selected if any one of the FS0-7 is active, and the secondary Flash Block is selected if any one of the CSBOOT0-3 is active.

The  
PSD835G2  
Functional  
Blocks  
(cont.)

Table 8. Instructions

Instruction	FS0-7 or CSBOOT0-3	Cycle 1	Cycle 2	Cycle 3	Cycle 4	Cycle5	Cycle 6	Cycle 7
Read (Note 5)	1	"Read" RA RD						
Read Main Flash ID (Notes 6,13)	1	AAh @555h	55h @AAAh	90h @555h	"Read" ID @x01h			
Read Sector Protection (Notes 6,8,13)	1	AAh @555h	55h @AAAh	90h @555h	"Read" 00h or 01h @x02h			
Program a Flash Byte	1	AAh @555h	55h @AAAh	A0h @555h	PD@PA			
Erase One Flash Sector	1	AAh @555h	55h @AAAh	80h @555h	AAh @555h	55h @AAAh	30h @SA	30h @next SA (Note 7)
Erase Flash Block (Bulk Erase)	1	AAh @555h	55h @AAAh	80h @555h	AAh @555h	55h @AAAh	10h @555h	
Suspend Sector Erase (Note 11)	1	B0h @xxxh						
Resume Sector Erase (Note 12)	1	30h @xxxh						
Reset (Note 6)	1	F0 @ any address						
Unlock Bypass	1	AAh @555h	55h @AAAh	20h @555h				
Unlock Bypass Program (Note 9)	1	A0h @xxxh	PD@PA					
Unlock Bypass Reset (Note 10)	1	90h @xxxh	00h @xxxh					

X = Don't Care.

RA = Address of the memory location to be read.

RD = Data read from location RA during read operation.

PA = Address of the memory location to be programmed. Addresses are latched on the falling edge of the WR# (CNTL0) pulse.

PD = Data to be programmed at location PA. Data is latched on the rising edge of WR# (CNTL0) pulse.

SA = Address of the sector to be erased or verified. The chip select (FS0-7 or CSBOOT0-3) of the sector to be erased must be active (high).

**NOTES:**

- All bus cycles are write bus cycle except the ones with the "read" label.
- All values are in hexadecimal.
- FS0-7 and CSBOOT0-3 are active high and are defined in PSDsoft.
- Only Address bits A11-A0 are used in Instruction decoding. A15-12 (or A16-A12) are don't care.
- No unlock or command cycles required when device is in read mode.
- The Reset command is required to return to the read mode after reading the Flash ID, Sector Protect status or if DQ5 (error flag) goes high.
- Additional sectors to be erased must be entered within 80µs.
- The data is 00h for an unprotected sector and 01h for a protected sector. In the fourth cycle, the sector chip select is active and (A1 = 1, A0 = 0).
- The Unlock Bypass command is required prior to the Unlock Bypass Program command.
- The Unlock Bypass Reset command is required to return to reading array data when the device is in the Unlock Bypass mode.
- The system may read and program functions in non-erasing sectors, read the Flash ID or read the Sector Protect status, when in the Erase Suspend mode. The erase Suspend command is valid only during a sector erase operation.
- The Erase Resume command is valid only during the Erase Suspend mode.
- The MCU cannot invoke these instructions while executing code from the same Flash memory for which the instruction is intended. The MCU must fetch, for example, codes from the secondary block when reading the Sector Protection Status of the main Flash.

## The PSD835G2 Functional Blocks (cont.)

### 9.1.1.5 Power-Up Condition

The PSD835G2 internal logic is reset upon power-up to the read array mode. The FSi and CSBOOTi select signals, along with the write strobe signal, must be in the false state during power-up for maximum security of the data contents and to remove the possibility of data being written on the first edge of a write strobe signal. Any write cycle initiation is locked when  $V_{CC}$  is below VLKO.

### 9.1.1.6 Read

Under typical conditions, the microcontroller may read the Flash, or secondary Flash memories using read operations just as it would a ROM or RAM device. Alternately, the microcontroller may use read operations to obtain status information about a program or erase operation in progress. Lastly, the microcontroller may use instructions to read special data from these memories. The following sections describe these read functions.

#### 9.1.1.6.1 Read the Contents of Memory

Main Flash and secondary Flash memories are placed in the read array mode after power-up, chip reset, or a Reset Flash instruction (see Table 8). The microcontroller can read the memory contents of main Flash or secondary Flash by using read operations any time the read operation is not part of an instruction sequence.

#### 9.1.1.6.2 Read the Main Flash Memory Identifier

The main Flash memory identifier is read with an instruction composed of 4 operations: 3 specific write operations and a read operation (see Table 8). The PSD835G2 main Flash memory ID is E8h.

#### 9.1.1.6.3 Read the Flash Memory Sector Protection Status

The Flash memory sector protection status is read with an instruction composed of 4 operations: 3 specific write operations and a read operation (see Table 8). The read operation will produce 01h if the Flash sector is protected, or 00h if the sector is not protected.

The sector protection status for all NVM blocks (main Flash or secondary Flash) can also be read by the microcontroller accessing the Flash Protection and Flash Boot Protection registers in PSD I/O space. See section 9.1.1.9.1 for register definitions.

#### 9.1.1.6.4 Read the Erase/Program Status Bits

The PSD835G2 provides several status bits to be used by the microcontroller to confirm the completion of an erase or programming instruction of Flash memory. These status bits minimize the time that the microcontroller spends performing these tasks and are defined in Table 9. The status bits can be read as many times as needed.

Table 9. Status Bits

	FSi/ CSBOOTi	DQ7	DQ6	DQ5	DQ4	DQ3	DQ2	DQ1	DQ0
Flash	$V_{IH}$	Data Polling	Toggle Flag	Error Flag	X	Erase Time- out	X	X	X

**NOTES:** 1. X = Not guaranteed value, can be read either 1 or 0.  
2. DQ7-DQ0 represent the Data Bus bits, D7-D0.  
3. FSi/CSBOOTi are active high.

For Flash memory, the microcontroller can perform a read operation to obtain these status bits while an erase or program instruction is being executed by the embedded algorithm. See section 9.1.1.7 for details.

## The PSD835G2 Functional Blocks (cont.)

### 9.1.1.6.5 Data Polling Flag DQ7

When Erasing or Programming the Flash memory bit DQ7 outputs the complement of the bit being entered for Programming/Writing on DQ7. Once the Program instruction or the Write operation is completed, the true logic value is read on DQ7 (in a Read operation). Flash memory specific features:

- Data Polling is effective after the fourth Write pulse (for programming) or after the sixth Write pulse (for Erase). It must be performed at the address being programmed or at an address within the Flash sector being erased.
- During an Erase instruction, DQ7 outputs a '0'. After completion of the instruction, DQ7 will output the last bit programmed (it is a '1' after erasing).
- If the location to be programmed is in a protected Flash sector, the instruction is ignored.
- If all the Flash sectors to be erased are protected, DQ7 will be set to '0' for about 100  $\mu$ s, and then return to the previous addressed location. No erasure will be performed.

### 9.1.1.6.6 Toggle Flag DQ6

The PSD835G2 offers another way for determining when the Flash memory Program instruction is completed. During the internal Write operation and when either the FSi or CSBOOTi is true, the DQ6 will toggle from '0' to '1' and '1' to '0' on subsequent attempts to read any byte of the memory.

When the internal cycle is complete, the toggling will stop and the data read on the Data Bus D0-7 is the addressed memory location. The device is now accessible for a new Read or Write operation. The operation is finished when two successive reads yield the same output data. Flash memory specific features:

- The Toggle bit is effective after the fourth Write pulse (for programming) or after the sixth Write pulse (for Erase).
- If the location to be programmed belongs to a protected Flash sector, the instruction is ignored.
- If all the Flash sectors selected for erasure are protected, DQ6 will toggle to '0' for about 100  $\mu$ s and then return to the previous addressed location.

### 9.1.1.6.7 Error Flag DQ5

During a correct Program or Erase, the Error bit will set to '0'. This bit is set to '1' when there is a failure during Flash programming, Sector erase, or Bulk Erase.

In the case of Flash programming, the Error Bit indicates the attempt to program a Flash bit(s) from the programmed state (0) to the erased state (1), which is not a valid operation. The Error bit may also indicate a timeout condition while attempting to program a byte.

In case of an error in Flash sector erase or byte program, the Flash sector in which the error occurred or to which the programmed location belongs must no longer be used. Other Flash sectors may still be used. The Error bit resets after the Reset instruction.

### 9.1.1.6.8 Erase Time-out Flag DQ3

The Erase Timer bit reflects the time-out period allowed between two consecutive Sector Erase instructions. The Erase timer bit is set to '0' after a Sector Erase instruction for a time period of 100  $\mu$ s + 20% unless an additional Sector Erase instruction is decoded. After this time period or when the additional Sector Erase instruction is decoded, DQ3 is set to '1'.

## The PSD835G2 Functional Blocks (cont.)

### 9.1.1.7 Programming Flash Memory

Flash memory must be erased prior to being programmed. The MCU may erase Flash memory all at once or by-sector. Flash memory sector erases to all logic ones (FF hex), and its bits are programmed to logic zeros. Although erasing Flash memory occurs on a sector basis, programming Flash memory occurs on a word basis.

The PSD835G2 main Flash and secondary Flash memories require the MCU to send an instruction to program a word or perform an erase function (see Table 8).

Once the MCU issues a Flash memory program or erase instruction, it must check for the status of completion. The embedded algorithms that are invoked inside the PSD835G2 support several means to provide status to the MCU. Status may be checked using any of three methods: Data Polling, Data Toggle, or the Ready/Busy output pin.

#### 9.1.1.7.1 Data Polling

Polling on DQ7 is a method of checking whether a Program or Erase instruction is in progress or has completed. Figure 4 shows the Data Polling algorithm.

When the MCU issues a programming instruction, the embedded algorithm within the PSD835G2 begins. The MCU then reads the location of the word to be programmed in Flash to check status. Data bit DQ7 of this location becomes the compliment of data bit 7 of the original data word to be programmed. The MCU continues to poll this location, comparing DQ7 and monitoring the Error bit on DQ5. When the DQ7 matches data bit 7 of the original data, and the Error bit at DQ5 remains '0', then the embedded algorithm is complete. If the Error bit at DQ5 is '1', the MCU should test DQ7 again since DQ7 may have changed simultaneously with DQ5 (see Figure 4).

The Error bit at DQ5 will be set if either an internal timeout occurred while the embedded algorithm attempted to program the location or if the MCU attempted to program a '1' to a bit that was not erased (not erased is logic '0').

It is suggested (as with all Flash memories) to read the location again after the embedded programming algorithm has completed to compare the word that was written to Flash with the word that was intended to be written.

When using the Data Polling method after an erase instruction, Figure 4 still applies. However, DQ7 will be '0' until the erase operation is complete. A '1' on DQ5 will indicate a timeout failure of the erase operation, a '0' indicates no error. The MCU can read any location within the sector being erased to get DQ7 and DQ5.

PSDsoft generates ANSI C code functions which implement these Data Polling algorithms.

The  
PSD835G2  
Functional  
Blocks  
(cont.)

Figure 4. Data Polling Flow Chart

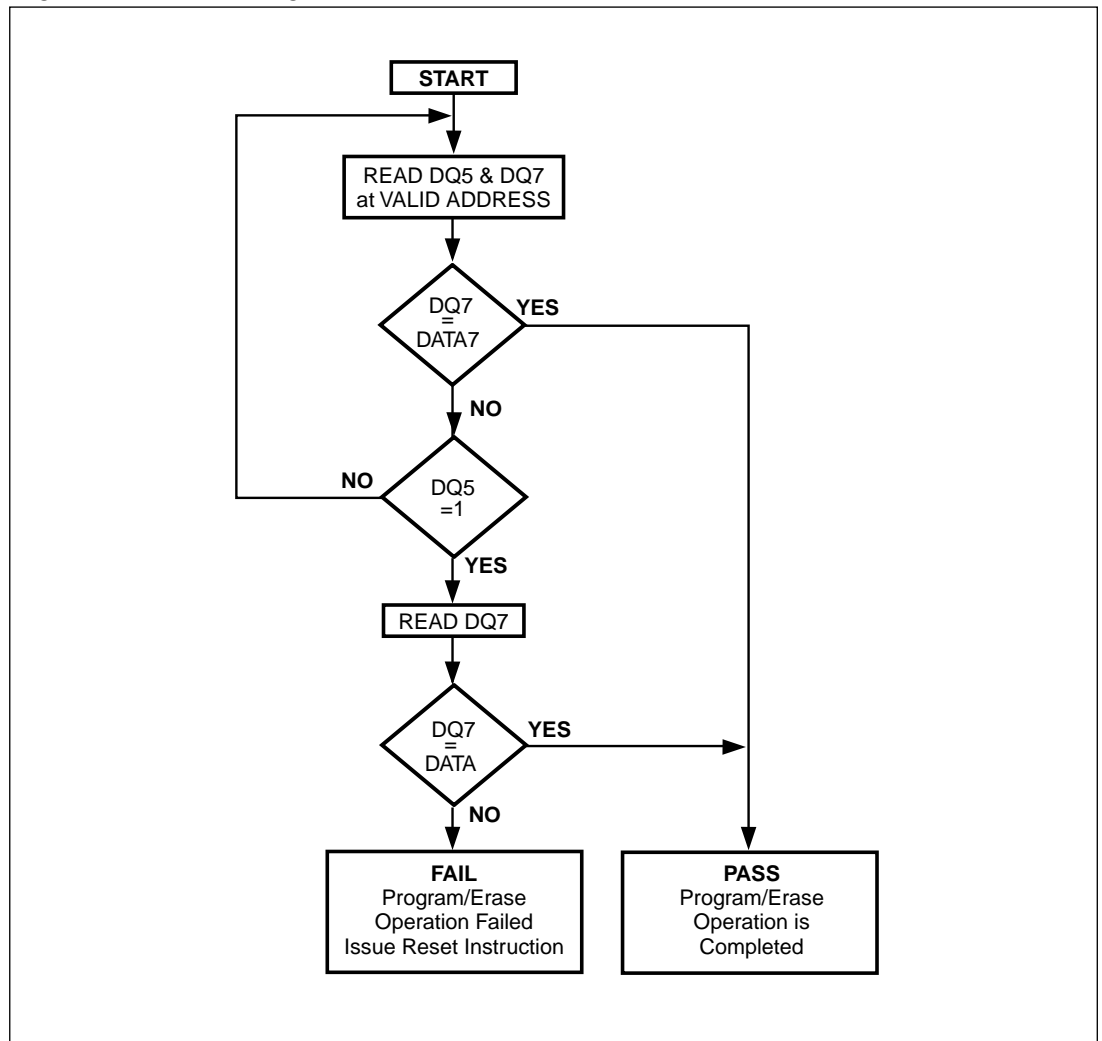

#### 9.1.1.7.2 Data Toggle

Checking the Data Toggle bit on DQ6 is a method of determining whether a Program or Erase instruction is in progress or has completed. Figure 5 shows the Data Toggle algorithm.

When the MCU issues a programming instruction, the embedded algorithm within the PSD835G2 begins. The MCU then reads the location to be programmed in Flash to check status. Data bit DQ6 of this location will toggle each time the MCU reads this location until the embedded algorithm is complete. The MCU continues to read this location, checking DQ6 and monitoring the Error bit on DQ5. When DQ6 stops toggling (two consecutive reads yield the same value), and the Error bit on DQ5 remains '0', then the embedded algorithm is complete. If the Error bit on DQ5 is '1', the MCU should test DQ6 again, since DQ6 may have changed simultaneously with DQ5 (see Figure 5).

The Error bit at DQ5 will be set if either an internal timeout occurred while the embedded algorithm attempted to program, or if the MCU attempted to program a '1' to a bit that was not erased (not erased is logic '0').

The PSD835G2 Functional Blocks (cont.)

9.1.1.7.2 Data Toggle (cont.)

It is suggested (as with all Flash memories) to read the location again after the embedded programming algorithm has completed to compare the word that was written to Flash with the word that was intended to be written.

When using the Data Toggle method after an erase instruction, Figure 5 still applies. DQ6 will toggle until the erase operation is complete. A '1' on DQ5 will indicate a timeout failure of the erase operation, a '0' indicates no error. The MCU can read any even location within the sector being erased to get DQ6 and DQ5.

PSDsoft generates ANSI C code functions which implement these Data Toggling algorithms.

Figure 5. Data Toggle Flow Chart

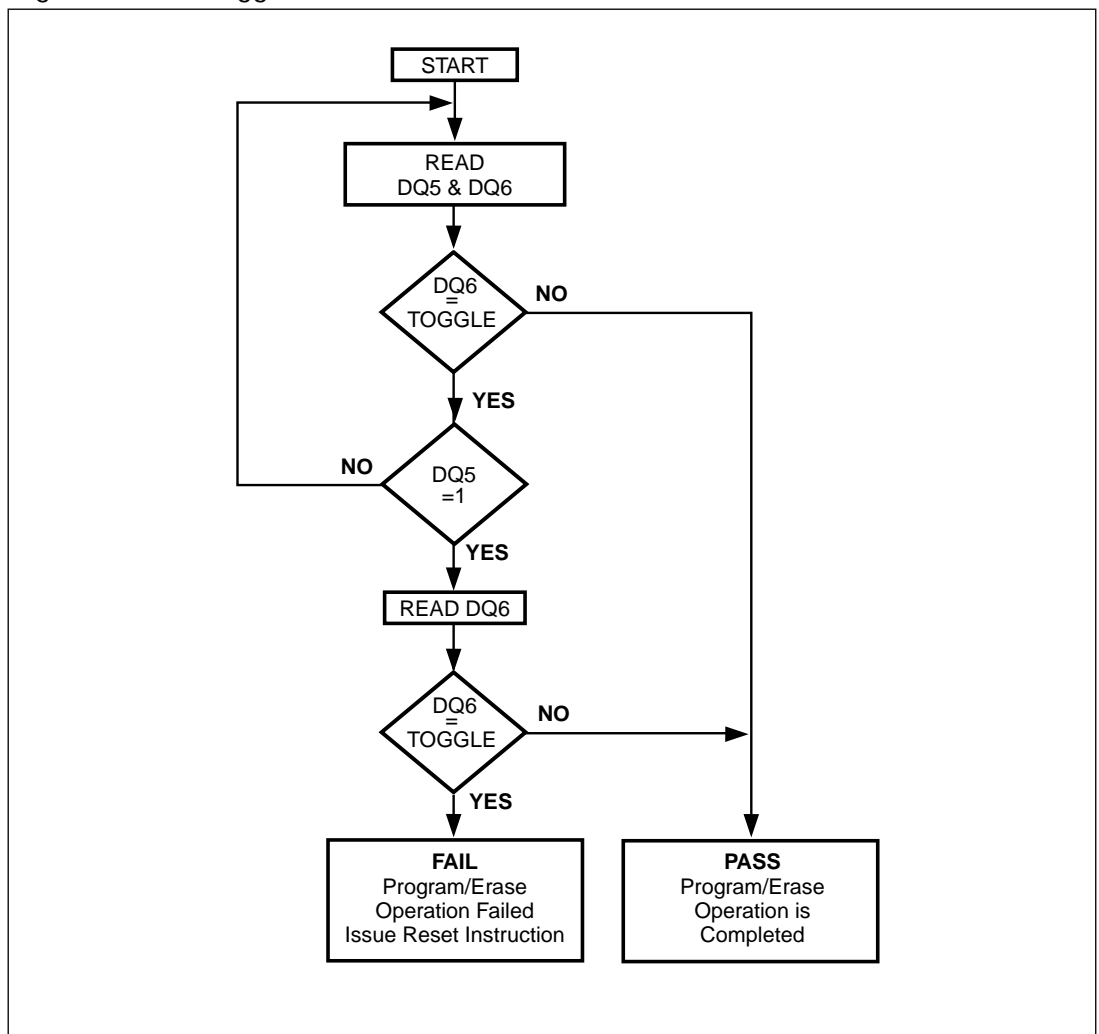

The  
PSD835G2  
Functional  
Blocks  
(cont.)

### 9.1.1.8 Unlock Bypass Instruction

The unlock bypass feature allows the system to program words to the flash memories faster than using the standard program instruction. The unlock bypass instruction is initiated by first writing two unlock cycles. This is followed by a third write cycle containing the unlock bypass command, 20h (see Table 8). The flash memory then enters the unlock bypass mode. A two-cycle Unlock Bypass Program instruction is all that is required to program in this mode. The first cycle in this instruction contains the unlock bypass programm command, A0h; the second cycle contains the program address and data. Additional data is programmed in the same manner. This mode dispenses with the initial two unlock cycles required in the standard program instruction, resulting in faster total programming time. During the unlock bypass mode, only the Unlock Bypass Program and Unlock Bypass Reset instructions are valid. To exit the unlock bypass mode, the system must issue the two-cycle unlock bypass reset instruction. The first cycle must contain the data 90h; the second cycle the data 00h. Addresses are don't care for both cycles. The Flash memory then returns to reading array data mode.

### 9.1.1.9 Erasing Flash Memory

#### 9.1.1.9.1. Flash Bulk Erase Instruction

The Flash Bulk Erase instruction uses six write operations followed by a Read operation of the status register, as described in Table 8. If any byte of the Bulk Erase instruction is wrong, the Bulk Erase instruction aborts and the device is reset to the Read Flash memory status.

During a Bulk Erase, the memory status may be checked by reading status bits DQ5, DQ6, and DQ7, as detailed in section 9.1.1.7. The Error bit (DQ5) returns a '1' if there has been an Erase Failure (maximum number of erase cycles have been executed).

It is not necessary to program the array with 00h because the PSD835G2 will automatically do this before erasing to 0FFh.

During execution of the Bulk Erase instruction, the Flash memory will not accept any instructions.

#### 9.1.1.9.2 Flash Sector Erase Instruction

The Sector Erase instruction uses six write operations, as described in Table 8. Additional Flash Sector Erase confirm commands and Flash sector addresses can be written subsequently to erase other Flash sectors in parallel, without further coded cycles, if the additional instruction is transmitted in a shorter time than the timeout period of about 100  $\mu$ s. The input of a new Sector Erase instruction will restart the time-out period.

The status of the internal timer can be monitored through the level of DQ3 (Erase time-out bit). If DQ3 is '0', the Sector Erase instruction has been received and the timeout is counting. If DQ3 is '1', the timeout has expired and the PSD835G2 is busy erasing the Flash sector(s). Before and during Erase timeout, any instruction other than Erase suspend and Erase Resume will abort the instruction and reset the device to Read Array mode. It is not necessary to program the Flash sector with 00h as the PSD835G2 will do this automatically before erasing.

During a Sector Erase, the memory status may be checked by reading status bits DQ5, DQ6, and DQ7, as detailed in section 9.1.1.7.

During execution of the erase instruction, the Flash block logic accepts only Reset and Erase Suspend instructions. Erasure of one Flash sector may be suspended, in order to read data from another Flash sector, and then resumed.

## The PSD835G2 Functional Blocks (cont.)

### 9.1.1.9.3 Flash Erase Suspend Instruction

When a Flash Sector Erase operation is in progress, the Erase Suspend instruction will suspend the operation by writing 0B0h to any even address when an appropriate Chip Select (FSi or CSBOOTi) is true. (See Table 8). This allows reading of data from another Flash sector after the Erase operation has been suspended. Erase suspend is accepted only during the Flash Sector Erase instruction execution and defaults to read array mode. An Erase Suspend instruction executed during an Erase timeout will, in addition to suspending the erase, terminate the time out.

The Toggle Bit DQ6 stops toggling when the PSD835G2 internal logic is suspended. The toggle Bit status must be monitored at an address within the Flash sector being erased. The Toggle Bit will stop toggling between 0.1  $\mu$ s and 15  $\mu$ s after the Erase Suspend instruction has been executed. The PSD835G2 will then automatically be set to Read Flash Block Memory Array mode.

If an Erase Suspend instruction was executed, the following rules apply:

- Attempting to read from a Flash sector that was being erased will output invalid data.
- Reading from a Flash sector that was **not** being erased is valid.
- The Flash memory **cannot** be programmed, and will only respond to Erase Resume and Reset instructions (read is an operation and is OK).
- If a Reset instruction is received, data in the Flash sector that was being erased will be invalid.

### 9.1.1.9.4 Flash Erase Resume Instruction

If an Erase Suspend instruction was previously executed, the erase operation may be resumed by this instruction. The Erase Resume instruction consists of writing 030h to any even address while an appropriate Chip Select (FSi or CSBOOTi) is true. (See Table 8.)

## 9.1.1.10 Specific Features

### 9.1.1.10.1 Main Flash and Secondary Flash Sector Protect

Each sector of main Flash and secondary Flash memory can be separately protected against Program and Erase functions. Sector Protection provides additional data security because it disables all program or erase operations. This mode can be activated (or deactivated) through the JTAG-ISP Port or a Device Programmer.

Sector protection can be selected for each sector using the PSDsoft program. This will automatically protect selected sectors when the device is programmed through the JTAG Port or a Device Programmer. Flash sectors can be unprotected to allow updating of their contents using the JTAG Port or a Device Programmer. The microcontroller can read (but cannot change) the sector protection bits.

Any attempt to program or erase a protected Flash sector will be ignored by the device. The Verify operation will result in a read of the protected data. This allows a guarantee of the retention of the Protection status.

The sector protection status can either be read by the MCU through the Flash protection and secondary Flash protection registers (CSIOP) or use the read sector protection instruction (Table 8).

The  
PSD835G2  
Functional  
Blocks  
(cont.)

Table 10. Sector Protection/Security Bit Definition

Flash Protection Register

Bit 7	Bit 6	Bit 5	Bit 4	Bit 3	Bit 2	Bit 1	Bit 0
Sec7_Prot	Sec6_Prot	Sec5_Prot	Sec4_Prot	Sec3_Prot	Sec2_Prot	Sec1_Prot	Sec0_Prot

Bit Definitions:

**Sec<i>\_Prot** 1 = Main Flash Sector <i> is write protected.**Sec<i>\_Prot** 0 = Main Flash Sector <i> is not write protected.

Flash Boot Protection Register

Bit 7	Bit 6	Bit 5	Bit 4	Bit 3	Bit 2	Bit 1	Bit 0
Security_ Bit	*	*	*	Sec3_Prot	Sec2_Prot	Sec1_Prot	Sec0_Prot

\*: Not used.

Bit Definitions:

**Sec<i>\_Prot** 1 = Flash Boot Sector <i> is write protected.**Sec<i>\_Prot** 0 = Flash Boot Sector <i> is not write protected.**Security\_Bit** 0 = Security Bit in device has not been set.

1 = Security Bit in device has been set.

## 9.1.1.10.2 Reset Instruction

The Reset instruction consists of one write cycle (see Table 8). It can also be optionally preceded by the standard two write decoding cycles (writing AAh to AAAh and 55h to 554h).

The Reset instruction must be executed after:

1. Reading the Flash Protection status or Flash ID using the Flash instruction.
2. When an error condition occurs (DQ5 goes high) during a Flash programming or erase cycle.

The Reset instruction will reset the Flash to normal Read Mode immediately. However, if there is an error condition (DQ5 goes high), the Flash memory will return to the Read Mode in 25  $\mu$ Seconds after the Reset instruction is issued.

The Reset instruction is ignored when it is issued during a Flash programming or Bulk Erase cycle. The Reset instruction will abort the on going sector erase cycle and return the Flash memory to normal Read Mode in 25  $\mu$ Seconds.

## 9.1.1.10.3 Reset Pin Input

The reset pulse input from the pin will abort any operation in progress and reset the Flash memory to Read Mode. When the reset occurs during a programming or erase cycle, the Flash memory will take up to 25  $\mu$ Seconds to return to Read Mode. It is recommended that the reset pulse (except power on reset, see Reset Section) be at least 25  $\mu$ Seconds such that the Flash memory will always be ready for the MCU to fetch the boot code after reset is over.

## The PSD835G2 Functional Blocks (cont.)

### 9.1.2 SRAM

The SRAM is enabled when RS0—the SRAM chip select output from the DPLD—is high. RS0 can contain up to three product terms, allowing flexible memory mapping.

The SRAM can be backed up using an external battery. The external battery should be connected to the Vstby pin (PE6). If you have an external battery connected to the PSD835G2, the contents of the SRAM will be retained in the event of a power loss. The contents of the SRAM will be retained so long as the battery voltage remains at 2V or greater. If the supply voltage falls below the battery voltage, an internal power switchover to the battery occurs.

Pin PE7 can be configured as an output that indicates when power is being drawn from the external battery. This Vbaton signal will be high with the supply voltage falls below the battery voltage and the battery on PE6 is supplying power to the internal SRAM.

The chip select signal (RS0) for the SRAM, Vstby, and Vbaton are all configured using PSDsoft.

### 9.1.3 Memory Select Signals

The main Flash (FSi), secondary Flash (CSBOOTi), and SRAM (RS0) memory select signals are all outputs of the DPLD. They are defined using PSDsoft. The following rules apply to the equations for the internal chip select signals:

1. Main Flash memory and secondary Flash memory sector select signals must **not** be larger than the physical sector size.
2. Any main Flash memory sector must **not** be mapped in the same memory space as another Main Flash sector.
3. A secondary Flash memory sector must **not** be mapped in the same memory space as another Flash Boot sector.
4. SRAM and I/O spaces must **not** overlap.
5. A secondary Flash memory sector **may** overlap a main Flash memory sector. In case of overlap, priority will be given to the Flash Boot sector.
6. SRAM and I/O spaces **may** overlap any other memory sector. Priority will be given to the SRAM and I/O.

#### Example

FS0 is valid when the address is in the range of 8000h to BFFFh, CSBOOT0 is valid from 8000h to 9FFFh, and RS0 is valid from 8000h to 87FFh. Any address in the range of RS0 will always access the SRAM. Any address in the range of CSBOOT0 greater than 87FFh (and less than 9FFFh) will automatically address Boot memory segment 0. Any address greater than 9FFFh will access the Flash memory segment 0. You can see that half of the Flash memory segment 0 and one-fourth of Boot segment 0 can not be accessed in this example. Also note that an equation that defined FS1 to anywhere in the range of 8000h to BFFFh would **not** be valid.

Figure 6 shows the priority levels for all memory components. Any component on a higher level can overlap and has priority over any component on a lower level. Components on the same level must **not** overlap. Level one has the highest priority and level 3 has the lowest.

The PSD835G2 Functional Blocks (cont.)

Figure 6. Priority Level of Memory and I/O Components

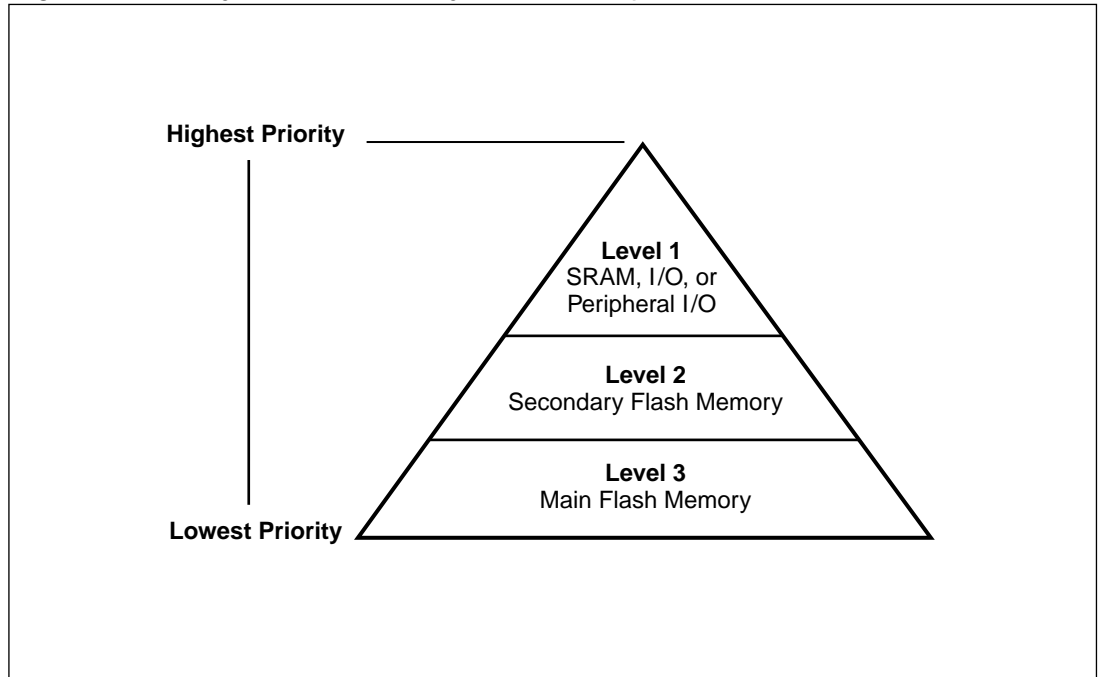

9.1.3.1. Memory Select Configuration for MCUs with Separate Program and Data Spaces

The 80C51 and compatible family of microcontrollers, can be configured to have separate address spaces for code memory (selected using PSEN) and data memory (selected using RD). Any of the memories within the PSD835G2 can reside in either space or both spaces. This is controlled through manipulation of the VM register that resides in the PSD’s CSIOP space.

The VM register is set using PSDsoft to have an initial value. It can subsequently be changed by the microcontroller so that memory mapping can be changed on-the-fly. For example, you may wish to have SRAM and main Flash in Data Space at boot, and secondary Flash memory in Program Space at boot, and later swap main and secondary Flash memory. This is easily done with the VM register by using PSDsoft to configure it for boot up and having the microcontroller change it when desired.

Table 11 describes the VM Register.

Table 11. VM Register

Bit 7 PIO_EN	Bit 6*	Bit 5*	Bit 4 FL_Data	Bit 3 Boot_Data	Bit 2 FL_Code	Bit 1 Boot_Code	Bit 0 SRAM_Code
0 = disable PIO mode	*	*	0 = RD can't access Flash	0 = RD can't access Boot Flash	0 = PSEN can't access Flash	0 = PSEN can't access Boot Flash	0 = PSEN can't access SRAM
1 = enable PIO mode	*	*	1 = RD access Flash	1 = RD access Boot Flash	1 = PSEN access Flash	1 = PSEN access Boot Flash	1 = PSEN access SRAM

**NOTE:** Bits 6-5 are not used.

The PSD835G2 Functional Blocks (cont.)

9.1.3.2 Configuration Modes for MCUs with Separate Program and Data Spaces

9.1.3.2.1 Separate Space Modes

Code memory space is separated from data memory space. For example, the PSEN signal is used to access the program code from the main Flash Memory, while the RD signal is used to access data from the secondary Flash memory, SRAM and I/O Ports. This configuration requires the VM register to be set to 0Ch.

9.1.3.2.2 . Combined Space Modes

The program and data memory spaces are combined into one space that allows the main Flash Memory, secondary Flash memory, and SRAM to be accessed by either PSEN or RD. For example, to configure the main Flash memory in combined space mode, bits 2 and 4 of the VM register are set to "1".

9.1.3.3 80C51XA Memory Map Example

See Application Notes for examples.

Figure 7. 80C51 Memory Modes – Separate Space Mode

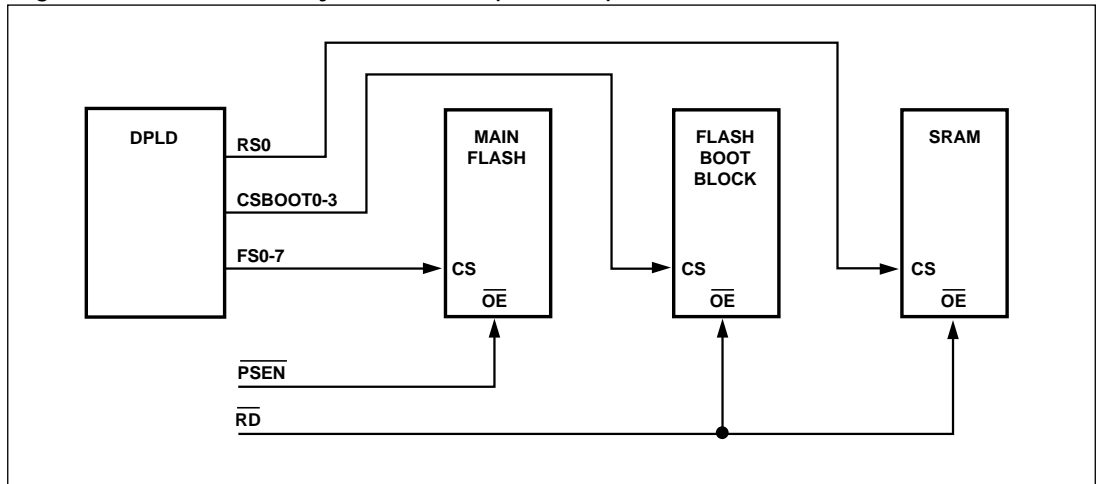
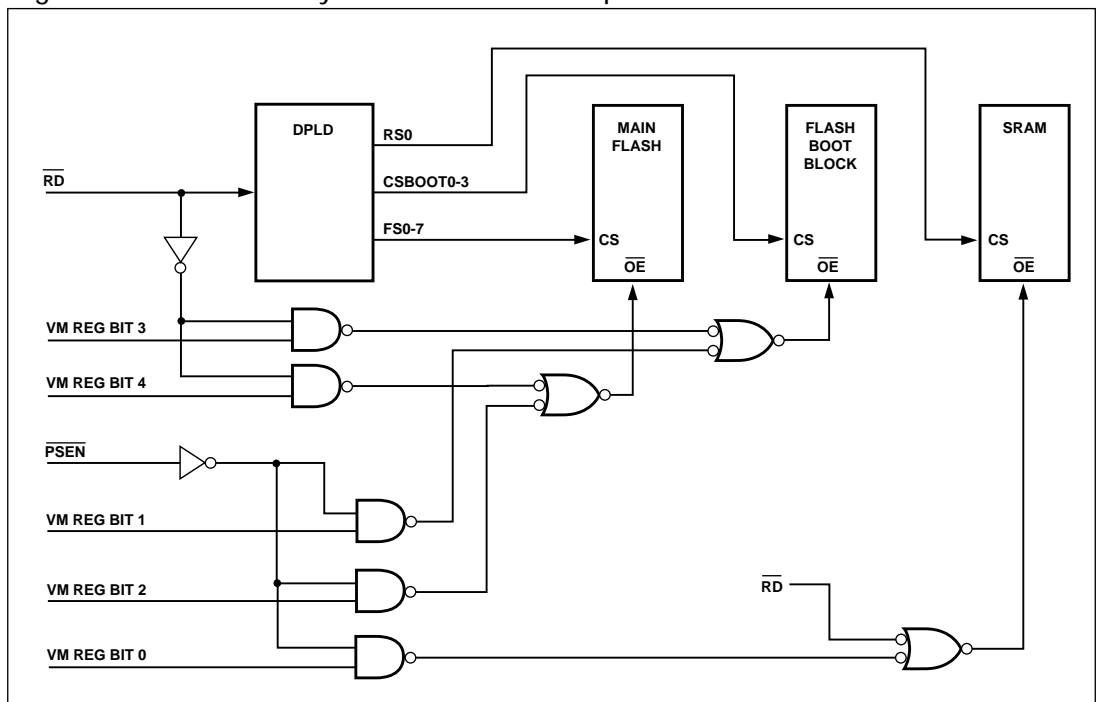

Figure 8. 80C51 Memory Mode – Combined Space Mode



The  
PSD835G2  
Functional  
Blocks  
(cont.)

### 9.1.4 Page Register

The eight bit Page Register increases the addressing capability of the microcontroller by a factor of up to 256. The contents of the register can also be read by the microcontroller. The outputs of the Page Register (PGR0-PGR7) are inputs to the PLD decoder and can be included in the Flash Memory, secondary Flash memory, and SRAM chip select equations.

If memory paging is not needed, or if not all 8 page register bits are needed for memory paging, then these bits may be used in the PLD for general logic. See Application Notes.

Figure 9 shows the Page Register. The eight flip flops in the register are connected to the internal data bus D0-D7. The microcontroller can write to or read from the Page Register. The Page Register can be accessed at address location CSIOP + E0h.

Figure 9. Page Register

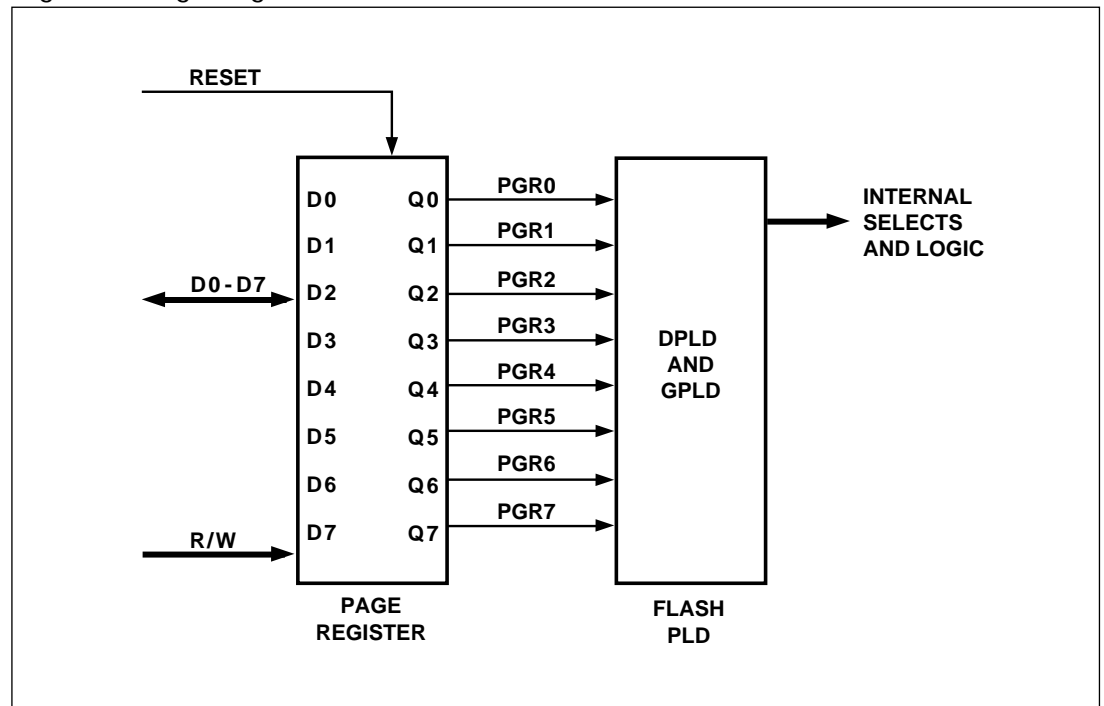

The  
PSD835G2  
Functional  
Blocks  
(cont.)

### 9.1.5 Memory ID Registers

The 8-bit read only memory status registers are included in the CSIOP space. The user can determine the memory configuration of the PSD device by reading the Memory ID0 and Memory ID1 registers. The content of the registers are defined as follow:

Memory\_ID0 Register

Bit 7	Bit 6	Bit 5	Bit 4	Bit 3	Bit 2	Bit 1	Bit 0
S_size 3	S_size 2	S_size 1	S_size 0	F_size 3	F_size 2	F_size 1	F_size 0

Bit Definition

F_size3	F_size2	F_size1	F_size0	Main Flash Size (Bit)
0	0	0	0	none
0	0	0	1	256K
0	0	1	0	512K
0	0	1	1	1M
0	1	0	0	2M
0	1	0	1	4M
0	1	1	0	8M

S_size3	S_size2	S_size1	S_size0	SRAM Size (Bit)
0	0	0	0	none
0	0	0	1	16K
0	0	1	0	32K
0	0	1	1	64K

Memory\_ID1 Register

Bit 7	Bit 6	Bit 5	Bit 4	Bit 3	Bit 2	Bit 1	Bit 0
*	*	B_type 1	B_type 0	B_size 3	B_size 2	B_size 1	B_size 0

\*Not used bit should be set to zero.

Bit Definition

B_size3	B_size2	B_size1	B_size0	Boot Block Size (Bit)
0	0	0	0	none
0	0	0	1	128K
0	0	1	0	256K
0	0	1	1	512K

B_type1	B_type0	Boot Block Type
0	0	Flash
0	1	EEPROM

The  
PSD835G2  
Functional  
Blocks  
(cont.)

## 9.2 PLDs

The PLDs bring programmable logic functionality to the PSD835G2. After specifying the logic for the PLDs in PSDsoft, the logic is programmed into the device and available upon power-up.

The PSD835G2 contains two PLDs: the Decode PLD (DPLD), and the Complex PLD (CPLD). The PLDs are briefly discussed in the next few paragraphs, and in more detail in sections 9.2.1 and 9.2.2. Figure 10 shows the configuration of the PLDs.

The DPLD performs address decoding for internal components, such as memory, registers, and I/O port selects.

The CPLD can be used for logic functions, such as loadable counters and shift registers, state machines, and encoding and decoding logic. These logic functions can be constructed using the 16 Output Micro↔Cells (OMCs), 24 Input Micro↔Cells (IMCs), and the AND array. The CPLD can also be used to generate external chip selects.

The AND array is used to form product terms. These product terms are specified using PSDsoft. An Input Bus consisting of 82 signals is connected to the PLDs. The signals are shown in Table 12.

Table 12. DPLD and CPLD Inputs

Input Source	Input Name	Number of Signals
MCU Address Bus	A[15:0]*	16
MCU Control Signals	CNTL[2:0]	3
Reset	RST	1
Power Down	PDN	1
Port A Input Micro↔Cells	PA[7:0]	8
Port B Input Micro↔Cells	PB[7:0]	8
Port C Input Micro↔Cells	PC[7:0]	8
Port D Inputs	PD[3:0]	4
Port F Inputs	PF[7:0]	8
Page Register	PGR(7:0)	8
Micro↔Cell A Feedback	MCELLA.FB[7:0]	8
Micro↔Cell B Feedback	MCELLB.FB[7:0]	8
Flash Programming Status Bit	Rdy/Bsy	1

**NOTE:** The address inputs are A[19:4] in 80C51XA mode.

### The Turbo Bit

The PLDs in the PSD835G2 can minimize power consumption by switching to standby when inputs remain unchanged for an extended time of about 70 ns. Setting the Turbo mode bit to off (Bit 3 of the PMMR0 register) automatically places the PLDs into standby if no inputs are changing. Turbo-off mode increases propagation delays while reducing power consumption. Refer to the Power Management Unit section on how to set the Turbo Bit. Additionally, five bits are available in the PMMR2 register to block MCU control signals from entering the PLDs. This reduces power consumption and can be used only when these MCU control signals are not used in PLD logic equations.

Figure 10. PLD Block Diagram

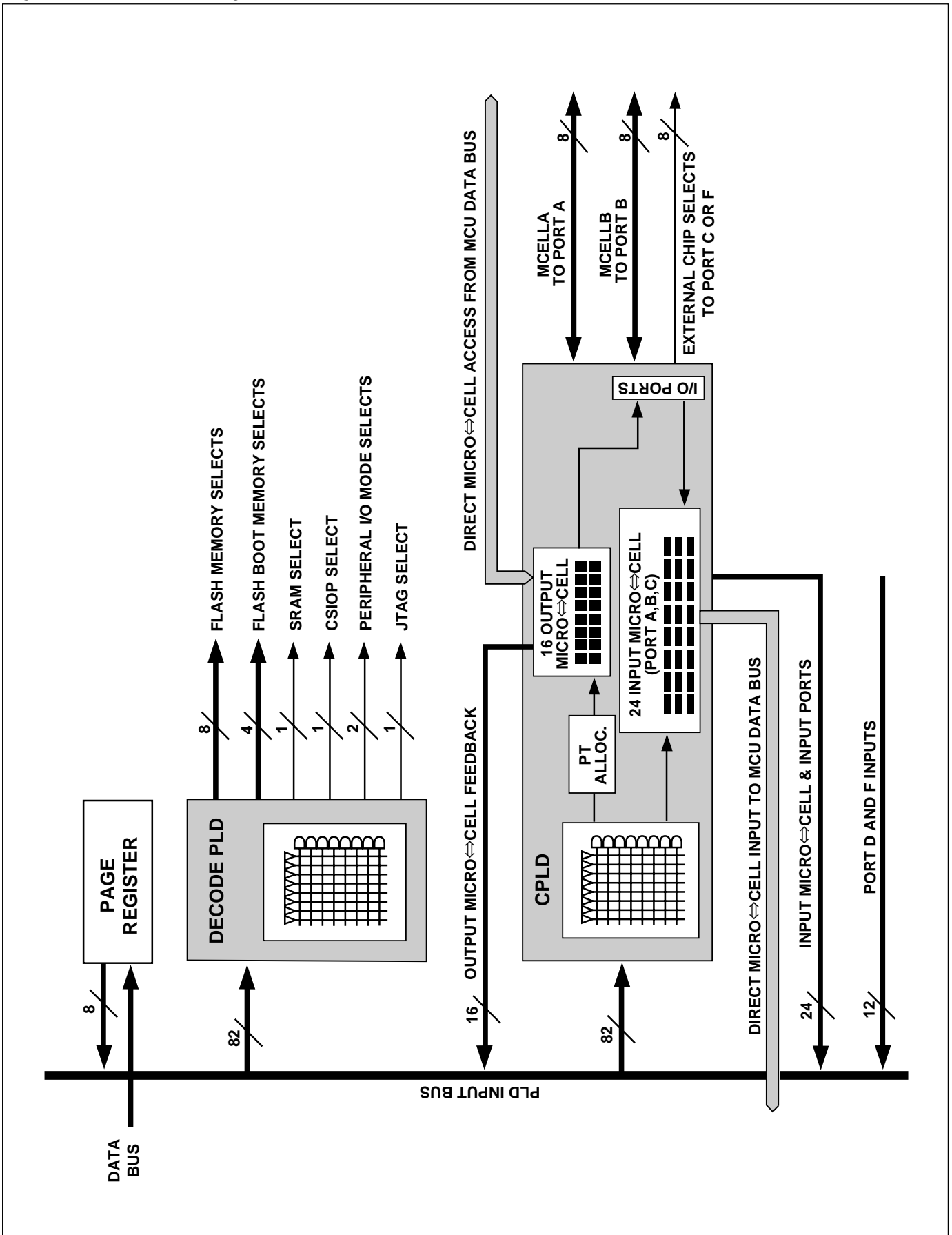

## The PSD835G2 Functional Blocks (cont.)

Each of the two PLDs has unique characteristics suited for its applications. They are described in the following sections.

### 9.2.1 Decode PLD (DPLD)

The DPLD, shown in Figure 11, is used for decoding the address for internal and external components. The DPLD can generate the following decode signals:

- 8 sector selects for the main Flash memory (three product terms each)
- 4 sector selects for the Flash Boot memory (three product terms each)
- 1 internal SRAM select signal (three product terms)
- 1 internal CSIOP (PSD configuration register) select signal
- 1 JTAG select signal (enables JTAG-ISP on Port E)
- 2 internal peripheral select signals (peripheral I/O mode).

### 9.2.2 Complex PLD (CPLD)

The CPLD can be used to implement system logic functions, such as loadable counters and shift registers, system mailboxes, handshaking protocols, state machines, and random logic. The CPLD can also be used to generate 8 external chip selects, routed to Port C or F. Although external chip selects can be produced by any Output Micro $\leftrightarrow$ Cell, these eight external chip selects on Port C or F do not consume any Output Micro $\leftrightarrow$ Cells.

As shown in Figure 10, the CPLD has the following blocks:

- 24 Input Micro $\leftrightarrow$ Cells (IMCs)
- 16 Output Micro $\leftrightarrow$ Cells (OMCs)
- Product Term Allocator
- AND array capable of generating up to 196 product terms
- Four I/O ports.

Each of the blocks are described in the subsections that follow.

The Input and Output Micro $\leftrightarrow$ Cells are connected to the PSD835G2 internal data bus and can be directly accessed by the microcontroller. This enables the MCU software to load data into the Output Micro $\leftrightarrow$ Cells or read data from both the Input and Output Micro $\leftrightarrow$ Cells. This feature allows efficient implementation of system logic and eliminates the need to connect the data bus to the AND logic array as required in most standard PLD macrocell architectures.

Figure 11. DPLD Logic Array

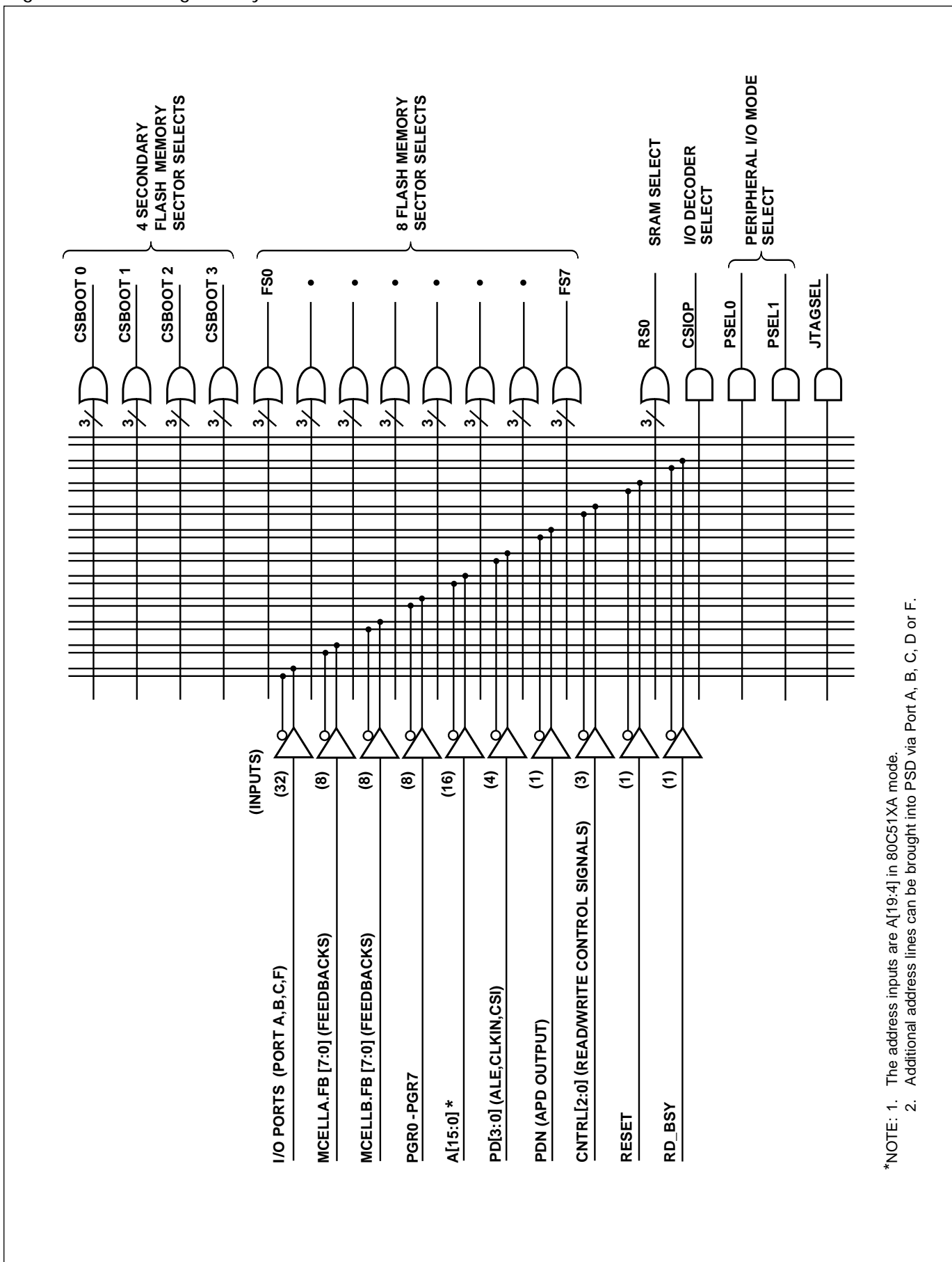
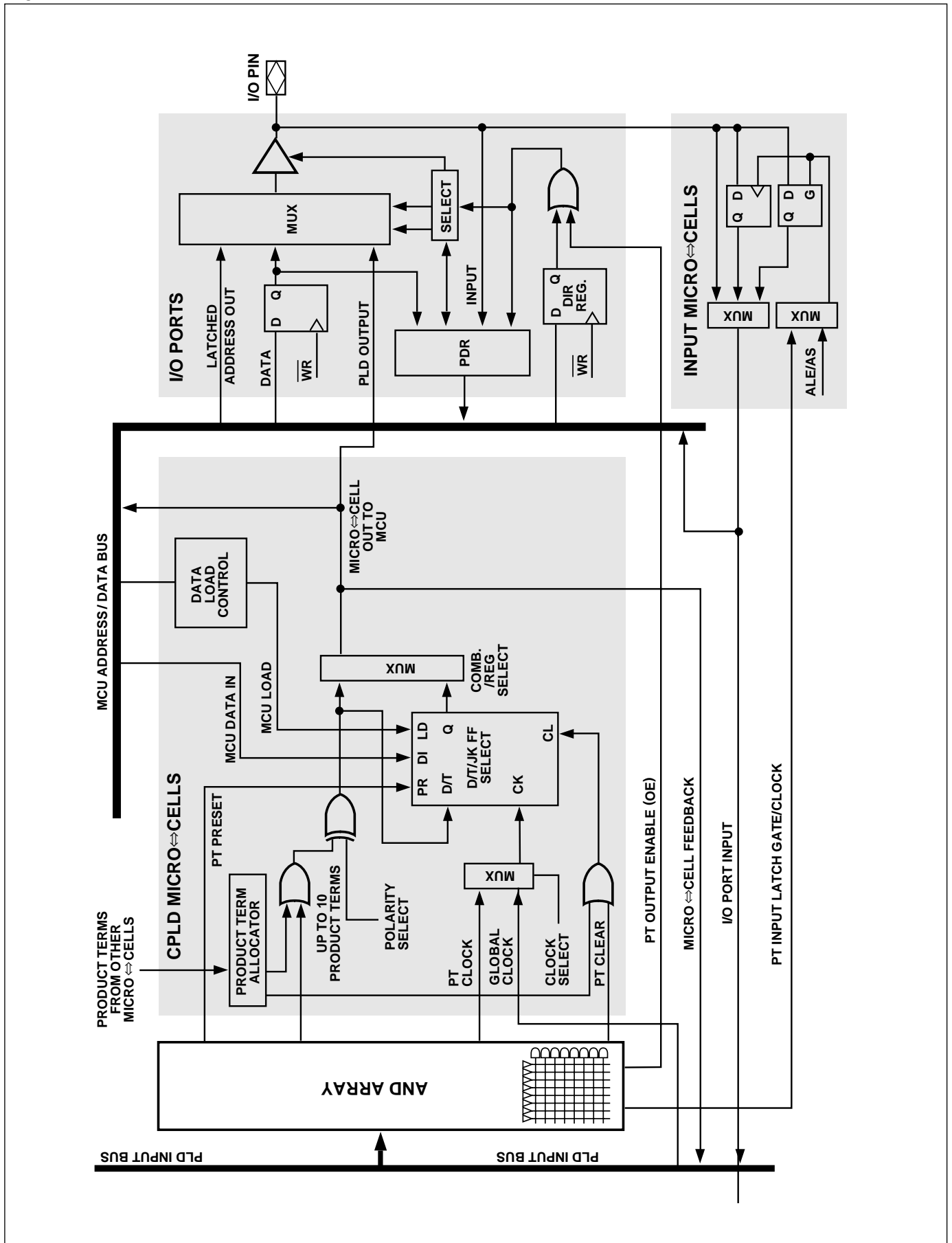

Figure 12. The Micro↔Cell and I/O Port



The  
PSD835G2  
Functional  
Blocks  
(cont.)

### 9.2.2.1 Output Micro $\leftrightarrow$ Cell

Eight of the Output Micro $\leftrightarrow$ Cells are connected to Port A pins are named as McellA0-7. The other eight Micro $\leftrightarrow$ Cells are connected to Port B pins are named as McellB0-7.

Table 13. Output Micro $\leftrightarrow$ Cell Port and Data Bit Assignments

Output Micro $\leftrightarrow$ Cell	Port Assignment	Native Product Terms	Maximum Borrowed Product Terms	Data Bit for Loading or Reading
McellA0	Port A0	3	6	D0
McellA1	Port A1	3	6	D1
McellA2	Port A2	3	6	D2
McellA3	Port A3	3	6	D3
McellA4	Port A4	3	6	D4
McellA5	Port A5	3	6	D5
McellA6	Port A6	3	6	D6
McellA7	Port A7	3	6	D7
McellB0	Port B0	4	5	D0
McellB1	Port B1	4	5	D1
McellB2	Port B2	4	5	D2
McellB3	Port B3	4	5	D3
McellB4	Port B4	4	6	D4
McellB5	Port B5	4	6	D5
McellB6	Port B6	4	6	D6
McellB7	Port B7	4	6	D7

The Output Micro $\leftrightarrow$ Cell (OMC) architecture is shown in Figure 13. As shown in the figure, there are native product terms available from the AND array, and borrowed product terms available (if unused) from other OMCs. The polarity of the product term is controlled by the XOR gate. The OMC can implement either sequential logic, using the flip-flop element, or combinatorial logic. The multiplexer selects between the sequential or combinatorial logic outputs. The multiplexer output can drive a Port pin and has a feedback path to the AND array inputs.

The flip-flop in the OMC can be configured as a D, T, JK, or SR type in the PSDsoft program. The flip-flop's clock, preset, and clear inputs may be driven from a product term of the AND array. Alternatively, the external CLKIN signal can be used for the clock input to the flip-flop. The flip-flop is clocked on the rising edge of the clock input. The preset and clear are active-high inputs. Each clear input can use up to two product terms.

## The PSD835G2 Functional Blocks (cont.)

### 9.2.2.2 The Product Term Allocator

The CPLD has a Product Term Allocator. The PSDsoft uses the Allocator to borrow and place product terms from one Micro $\leftrightarrow$ Cell to another. The following list summarizes how product terms are allocated:

- McellA0-7 all have three native product terms and may borrow up to six more
- McellB0-3 all have four native product terms and may borrow up to five more
- McellB4-7 all have four native product terms and may borrow up to six more.

Each Micro $\leftrightarrow$ Cell may only borrow product terms from certain other Micro $\leftrightarrow$ Cells. Product terms already in use by one Micro $\leftrightarrow$ Cell will not be available for a different Micro $\leftrightarrow$ Cell.

If an equation requires more product terms than what is available to it, then “external” product terms will be required, which will consume other OMCs. If external product terms are used, extra delay will be added for the equation that required the extra product terms. This is called product term expansion. PSDsoft will perform this expansion as needed.

### 9.2.2.3 Loading and Reading the Output Micro $\leftrightarrow$ Cells (OMCs)

The OMCs occupy a memory location in the MCU address space, as defined by the CSIOP (refer to the I/O section). The flip-flops in each of the 16 OMCs can be loaded from the data bus by a microcontroller. Loading the OMCs with data from the MCU takes priority over internal functions. As such, the preset, clear, and clock inputs to the flip-flop can be overridden by the MCU. The ability to load the flip-flops and read them back is useful in such applications as loadable counters and shift registers, mailboxes, and handshaking protocols. Data is loaded to the OMCs on the trailing edge of the WR signal .

### 9.2.2.4 The OMC Mask Register

There is one Mask Register for each of the two groups of eight OMCs. The Mask Registers can be used to block the loading of data to individual OMCs. The default value for the Mask Registers is 00h, which allows loading of the OMCs. When a given bit in a Mask Register is set to a ‘1’, the MCU will be blocked from writing to the associated OMC. For example, suppose McellA0-3 are being used for a state machine. You would not want a MCU write to McellA to overwrite the state machine registers. Therefore, you would want to load the Mask Register for McellA (Mask Micro $\leftrightarrow$ Cell A) with the value 0Fh.

### 9.2.2.5 The Output Enable of the OMC

The OMC can be connected to an I/O port pin as a PLD output. The output enable of each Port pin driver is controlled by a single product term from the AND array, ORed with the Direction Register output. The pin is enabled upon power up if no output enable equation is defined and if the pin is declared as a PLD output in PSDsoft.

If the OMC output is declared as an internal node and not as a Port pin output in the PSDabel file, then the Port pin can be used for other I/O functions. The internal node feedback can be routed as an input to the AND array.

The PSD835G2 Functional Blocks (cont.)

Figure 13. CPLD Output Micro↔Cell

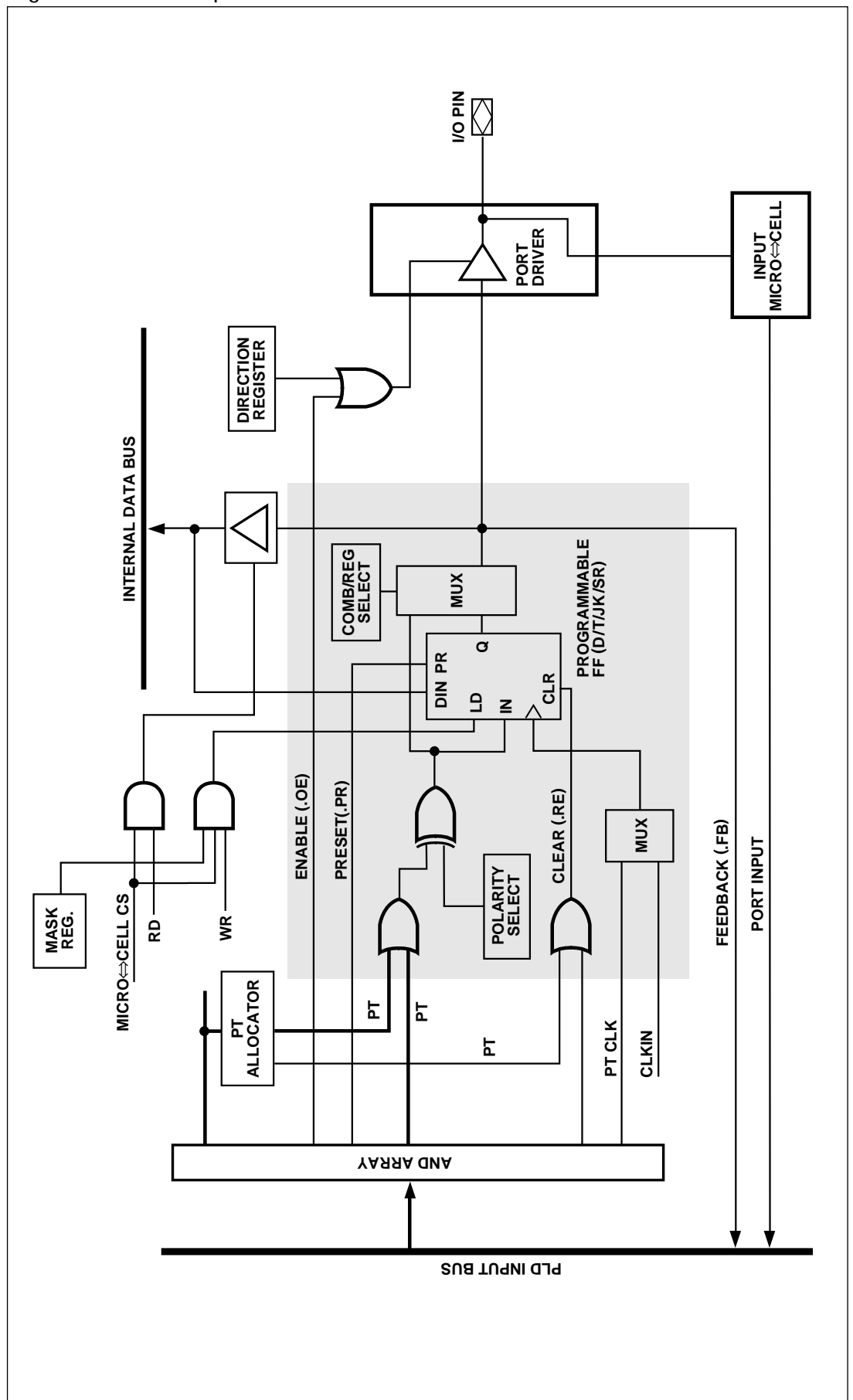

The PSD835G2 Functional Blocks (cont.)

9.2.2.6 Input Micro⇔Cells (IMCs)

The CPLD has 24 IMCs, one for each pin on Ports A, B, and C. The architecture of the IMC is shown in Figure 14. The IMCs are individually configurable, and can be used as a latch, register, or to pass incoming Port signals prior to driving them onto the PLD input bus. The outputs of the IMCs can be read by the microcontroller through the internal data bus.

The enable for the latch and clock for the register are driven by a multiplexer whose inputs are a product term from the CPLD AND array or the MCU address strobe (ALE/AS). Each product term output is used to latch or clock four IMCs. Port inputs 3-0 can be controlled by one product term and 7-4 by another.

Configurations for the IMCs are specified by PSDsoft. Outputs of the IMCs can be read by the MCU via the IMC buffer. See the I/O Port section on how to read the IMCs.

IMCs can use the address strobe to latch address bits higher than A15. Any latched addresses are routed to the PLDs as inputs.

IMCs are particularly useful with handshaking communication applications where two processors pass data back and forth through a common mailbox. Figure 15 shows a typical configuration where the Master MCU writes to the Port A Data Out Register. This, in turn, can be read by the Slave MCU via the activation of the "Slave-Read" output enable product term. The Slave can also write to the Port A IMCs and the Master can then read the IMCs directly. Note that the "Slave-Read" and "Slave-Wr" signals are product terms that are derived from the Slave MCU inputs RD, WR, and Slave\_CS.

Figure 14. Input Micro⇔Cell

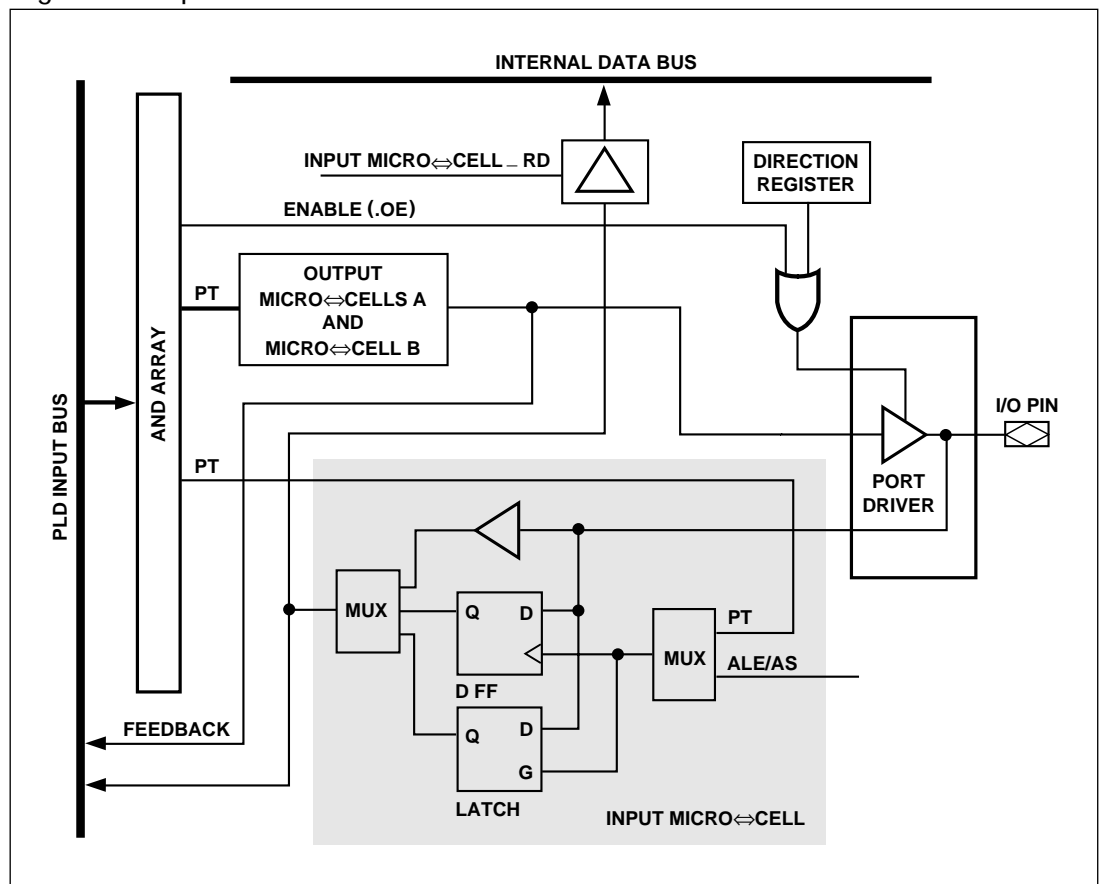

The PSD835G2 Functional Blocks (cont.)

Figure 15. Handshaking Communication Using Input Micro⇌Cells

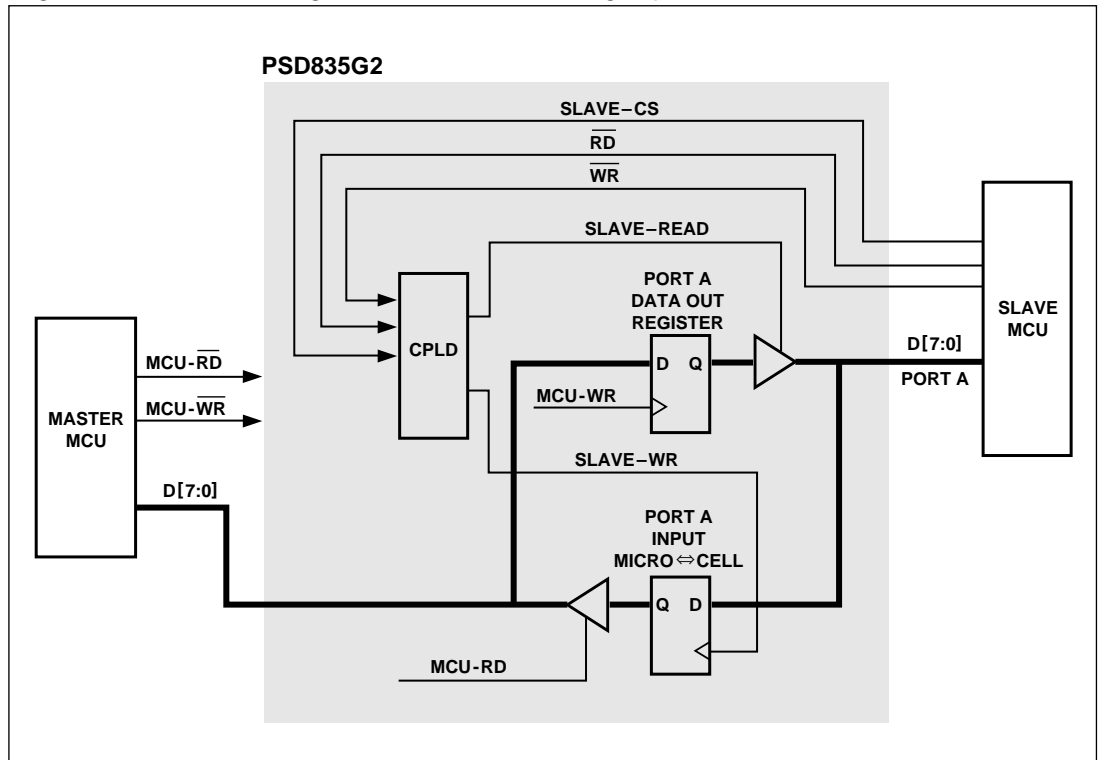

9.2.2.7 External Chip Select

The CPLD also provides eight chip select outputs that can be used to select external devices. The chip selects can be routed to either Port C or Port F, depending on the pin declaration in the PSDsoft. Each chip select (ECS0-7) consists of one product term that can be configured active high or low.

The output enable of the pin is controlled by either the output enable product term or the Direction Register. (See Figure 16).

Figure 16. External Chip Select

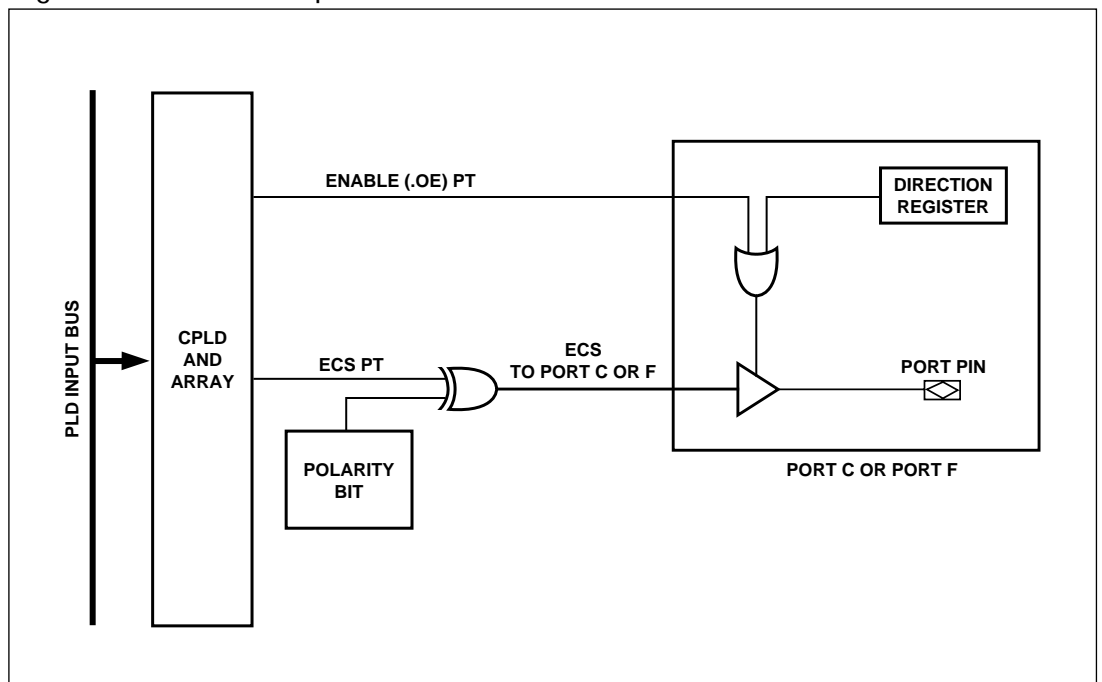

The  
PSD835G2  
Functional  
Blocks  
(cont.)

### 9.3 Microcontroller Bus Interface

The “no-glue logic” PSD835G2 Microcontroller Bus Interface can be directly connected to most popular microcontrollers and their control signals. Key 8-bit microcontrollers with their bus types and control signals are shown in Table 14. The MCU interface type is specified using the PSDsoft.

Table 14. Microcontrollers and their Control Signals

MCU	Data Bus Width	CNTL0	CNTL1	CNTL2	PC7	PD0**	ADIO0	PF3-PF0	PF7-PF4
8031/8051	8	$\overline{WR}$	$\overline{RD}$	$\overline{PSEN}$	*	ALE	A0	*	*
80C51XA	8	$\overline{WR}$	$\overline{RD}$	$\overline{PSEN}$	*	ALE	A4	A3-A0	*
80C251	8	$\overline{WR}$	$\overline{PSEN}$	*	*	ALE	A0	*	*
80C251	8	$\overline{WR}$	$\overline{RD}$	$\overline{PSEN}$	*	ALE	A0	*	*
80198	8	$\overline{WR}$	$\overline{RD}$	*	*	ALE	A0	*	*
68HC11	8	$R/\overline{W}$	E	*	*	AS	A0	*	*
68HC05C0	8	$\overline{WR}$	$\overline{RD}$	*	*	AS	A0	*	*
68HC912	8	$R/\overline{W}$	E	*	$\overline{DBE}$	AS	A0	*	*
Z80	8	$\overline{WR}$	$\overline{RD}$	*	*	*	A0	D3-D0	D7-D4
Z8	8	$R/\overline{W}$	$\overline{DS}$	*	*	$\overline{AS}$	A0	*	*
68330	8	$R/\overline{W}$	$\overline{DS}$	*	*	AS	A0	*	*
M37702M2	8	$R/\overline{W}$	$\overline{E}$	*	*	ALE	A0	D3-D0	D7-D4

\*Unused CNTL2 pin can be configured as PLD input. Other unused pins (PD3-0, PA3-0) can be configured for other I/O functions.

\*\*ALE/AS input is optional for microcontrollers with a non-multiplexed bus

#### 9.3.1. PSD835G2 Interface to a Multiplexed Bus

Figure 17 shows an example of a system using a microcontroller with a 8-bit multiplexed bus and a PSD835G2. The ADIO port on the PSD835G2 is connected directly to the microcontroller address/data bus. ALE latches the address lines internally. Latched addresses can be brought out to Port E, F or G. The PSD835G2 drives the ADIO data bus only when one of its internal resources is accessed and the RD input is active. Should the system address bus exceed sixteen bits, Ports A, B, C, or F may be used as additional address inputs.

#### 9.3.2. PSD835G2 Interface to a Non-Multiplexed Bus

Figure 18 shows an example of a system using a microcontroller with a 8-bit non-multiplexed bus and a PSD835G2. The address bus is connected to the ADIO Port, and the data bus is connected to Port F. Port F is in tri-state mode when the PSD835G2 is not accessed by the microcontroller. Should the system address bus exceed sixteen bits, Ports A, B or C may be used for additional address inputs.

The PSD835G2 Functional Blocks (cont.)

Figure 17. An Example of a Typical 8-Bit Multiplexed Bus Interface

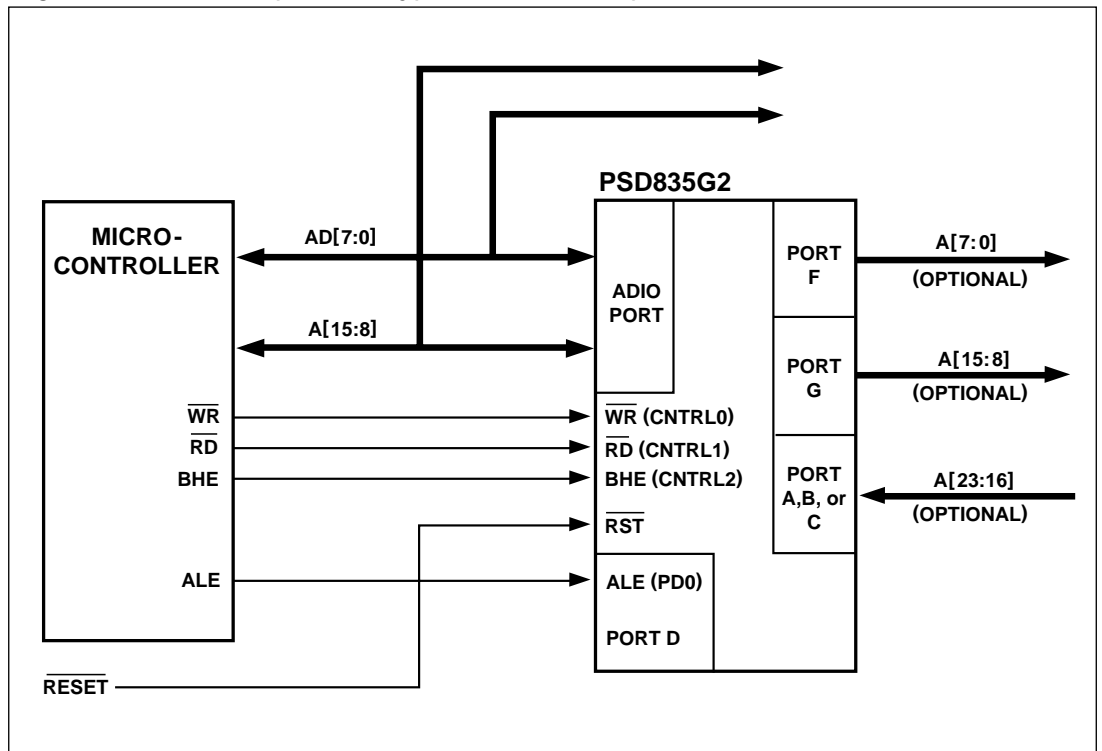
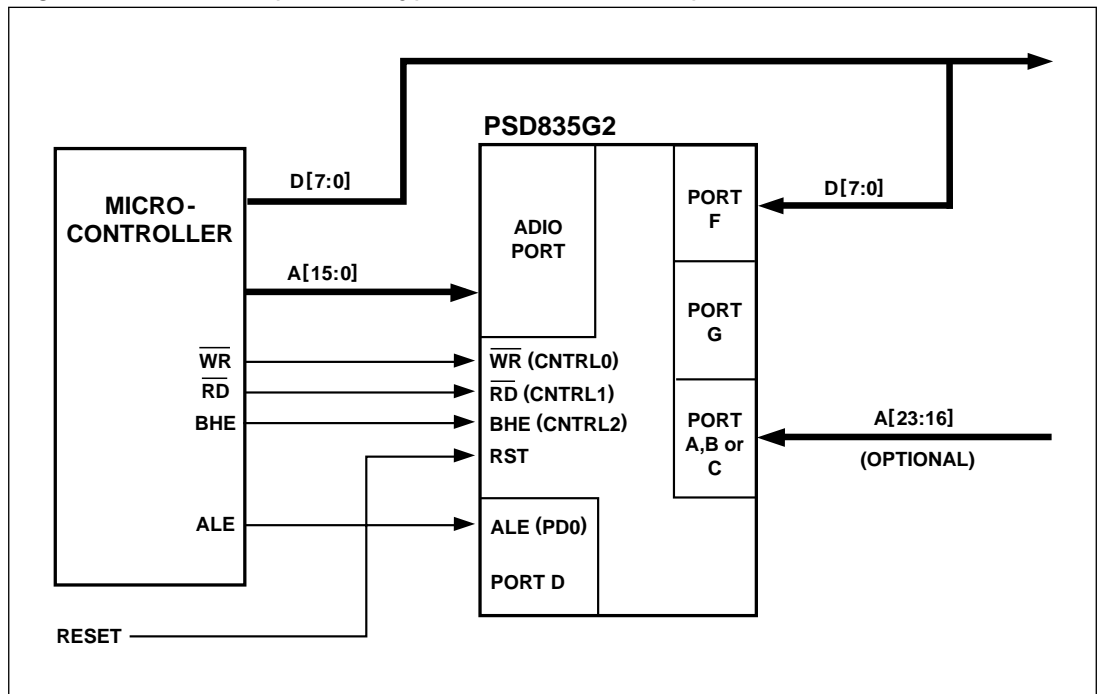

Figure 18. An Example of a Typical 8-Bit Non-Multiplexed Bus Interface



---

The  
PSD835G2  
Functional  
Blocks  
(cont.)

### 9.3.3 Microcontroller Interface Examples

Figures 19 through 23 show examples of the basic connections between the PSD835G2 and some popular microcontrollers. The PSD835G2 Control input pins are labeled as to the microcontroller function for which they are configured. The MCU interface is specified using the PSDsoft.

#### 9.3.3.1 80C31

Figure 19 shows the interface to the 80C31, which has an 8-bit multiplexed address/data bus. The lower address byte is multiplexed with the data bus. The microcontroller control signals PSEN, RD, and WR may be used for accessing the internal memory components and I/O Ports. The ALE input (pin PD0) latches the address.

#### 9.3.3.2 80C251

The Intel 80C251 microcontroller features a user-configurable bus interface with four possible bus configurations, as shown in Table 15.

Configuration 1 is 80C31 compatible, and the bus interface to the PSD835G2 is identical to that shown in Figure 19. Configurations 2 and 3 have the same bus connection as shown in Figure 20. There is only one read input (PSEN) connected to the Cntl1 pin on the PSD835G2. The A16 connection to the PA0 pin allows for a larger address input to the PSD835G2. Configuration 4 is shown in Figure 21. The RD signal is connected to Cntl1 and the PSEN signal is connected to the CNTL2.

The 80C251 has two major operating modes: Page Mode and Non-Page Mode. In Non-Page Mode, the data is multiplexed with the lower address byte, and ALE is active in every bus cycle. In Page Mode, data D[7:0] is multiplexed with address A[15:8]. In a bus cycle where there is a Page hit, the ALE signal is not active and only addresses A[7:0] are changing. The PSD835G2 supports both modes. In Page Mode, the PSD bus timing is identical to Non-Page Mode except the address hold time and setup time with respect to ALE is not required. The PSD access time is measured from address A[7:0] valid to data in valid.

The  
PSD835G2  
Functional  
Blocks  
(cont.)

Table 15. 80C251 Configurations

Configuration	80C251 Read/Write Pins	Connecting to PSD835G2 Pins	Page Mode
1	$\overline{WR}$ $\overline{RD}$ $\overline{PSEN}$	CNTL0 CNTL1 CNTL2	Non-Page Mode, 80C31 compatible A[7:0] multiplex with D[7:0]
2	$\overline{WR}$ $\overline{PSEN}$ only	CNTL0 CNTL1	Non-Page Mode A[7:0] multiplex with D[7:0]
3	$\overline{WR}$ $\overline{PSEN}$ only	CNTL0 CNTL1	Page Mode A[15:8] multiplex with D[7:0]
4	$\overline{WR}$ $\overline{RD}$ $\overline{PSEN}$	CNTL0 CNTL1 CNTL2	Page Mode A[15:8] multiplex with D[7:0]

## 9.3.3.3 80C51XA

The Philips 80C51XA microcontroller family supports an 8- or 16-bit multiplexed bus that can have burst cycles. Address bits A[3:0] are not multiplexed, while A[19:4] are multiplexed with data bits D[15:0] in 16-bit mode. In 8-bit mode, A[11:4] are multiplexed with data bits D[7:0].

The 80C51XA can be configured to operate in eight-bit data mode. (shown in Figure 22). The 80C51XA improves bus throughput and performance by executing Burst cycles for code fetches. In Burst Mode, address A19-4 are latched internally by the PSD835G2, while the 80C51XA changes the A3-0 lines to fetch up to 16 bytes of code. The PSD access time is then measured from address A3-A0 valid to data in valid. The PSD bus timing requirement in Burst Mode is identical to the normal bus cycle, except the address setup and hold time with respect to ALE does not apply.

## 9.3.3.4 68HC11

Figure 23 shows an interface to a 68HC11 where the PSD835G2 is configured in 8-bit multiplexed mode with  $\overline{E}$  and R/W settings. The DPLD can generate the READ and WR signals for external devices.

Figure 19. Interfacing the PSD835G2 with an 80C31

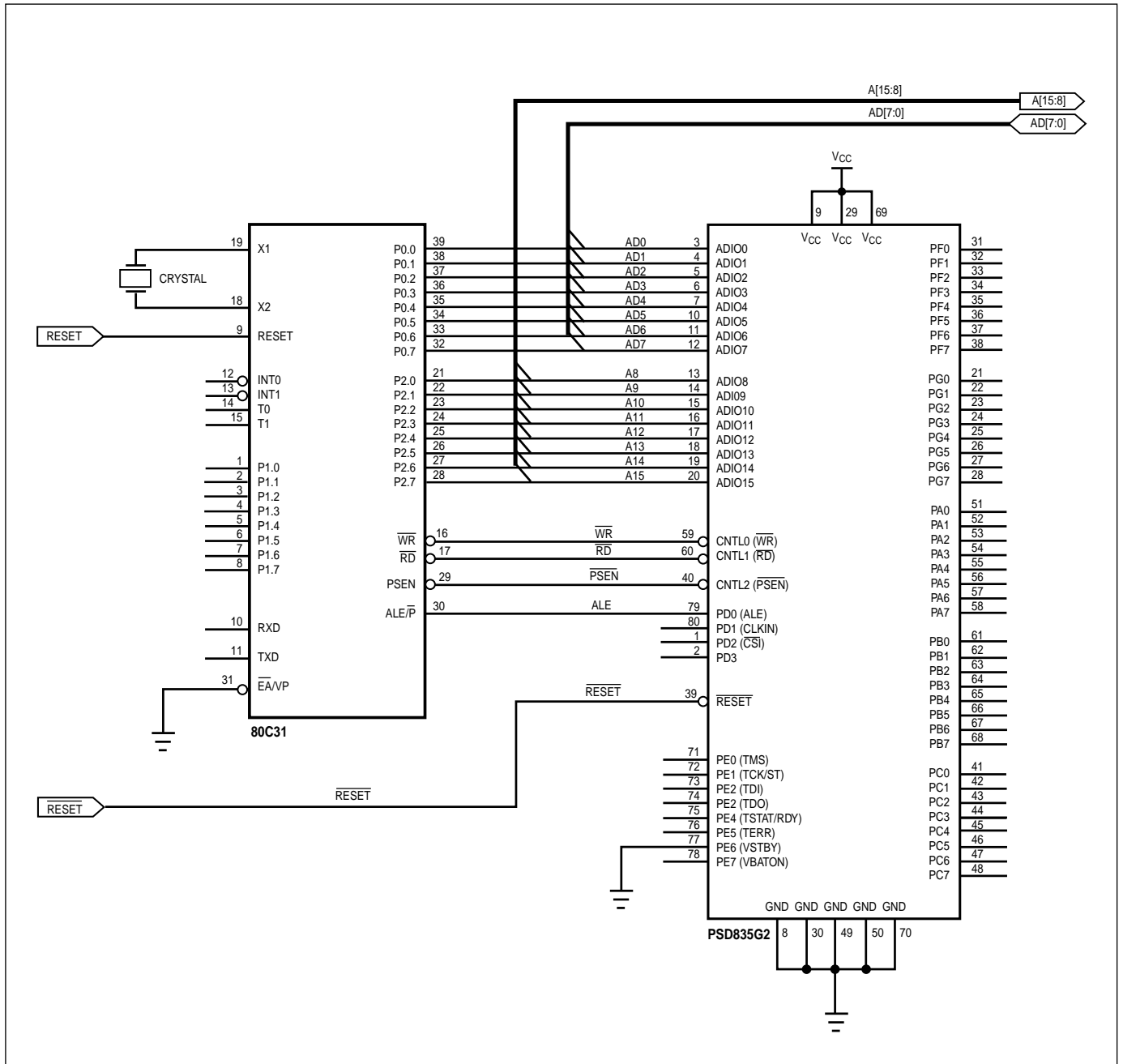

Figure 20. Interfacing the PSD835G2 to the 80C251, with One Read Input

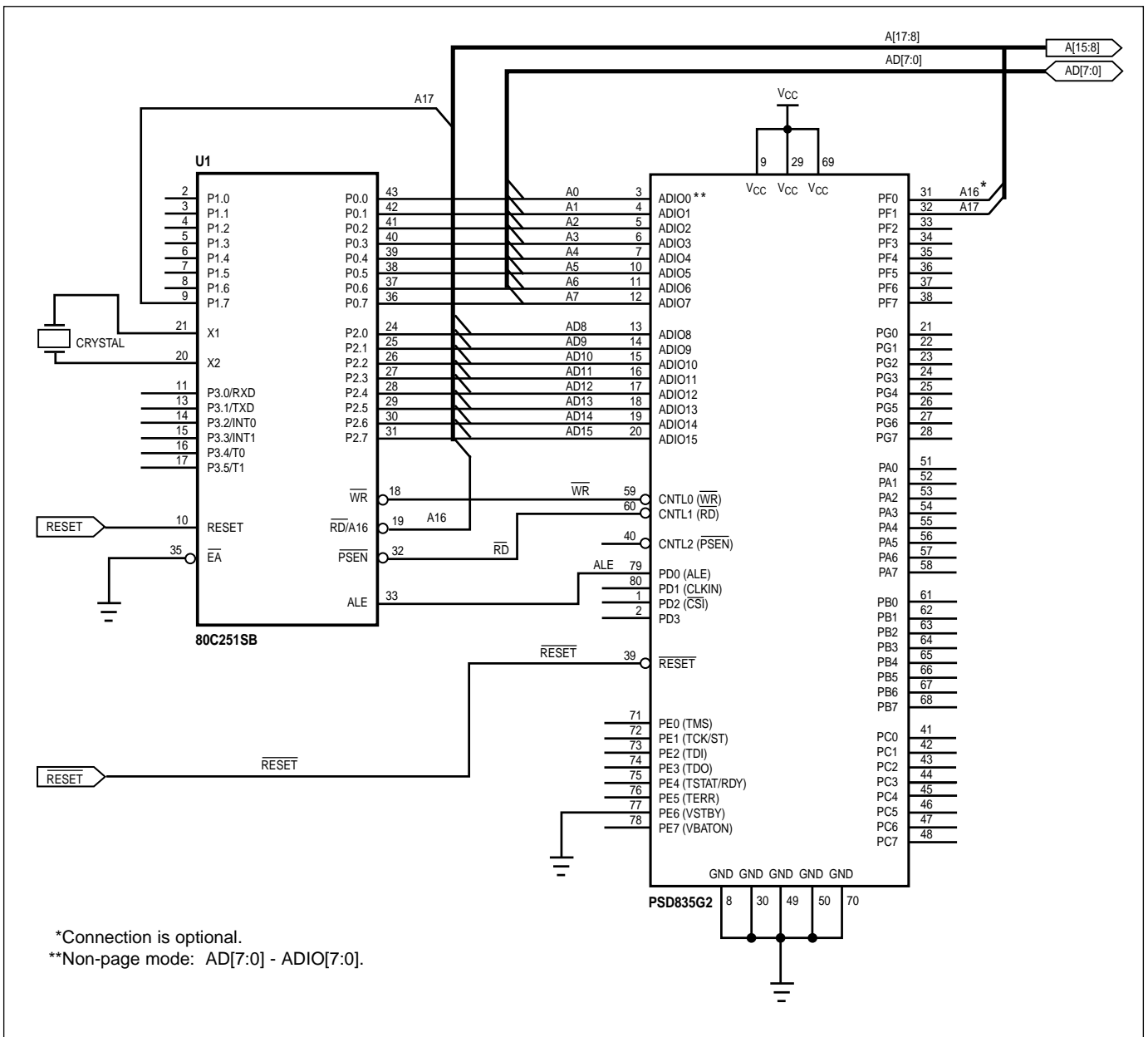

Figure 21. Interfacing the PSD835G2 to the 80C251, with Read and PSEN Inputs

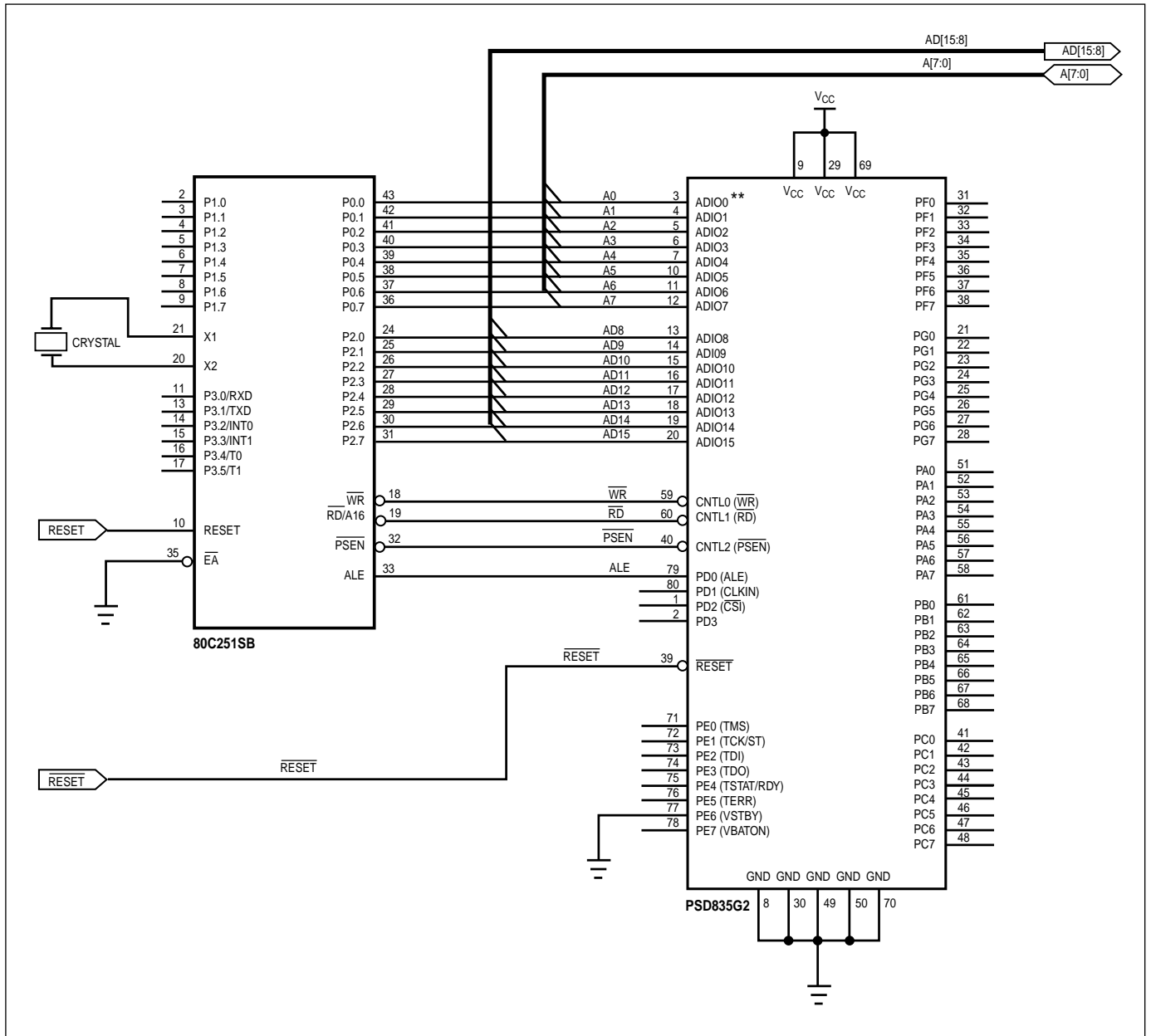

Figure 22. Interfacing the PSD835G2 to the 80C51XA, 8-Bit Data Bus

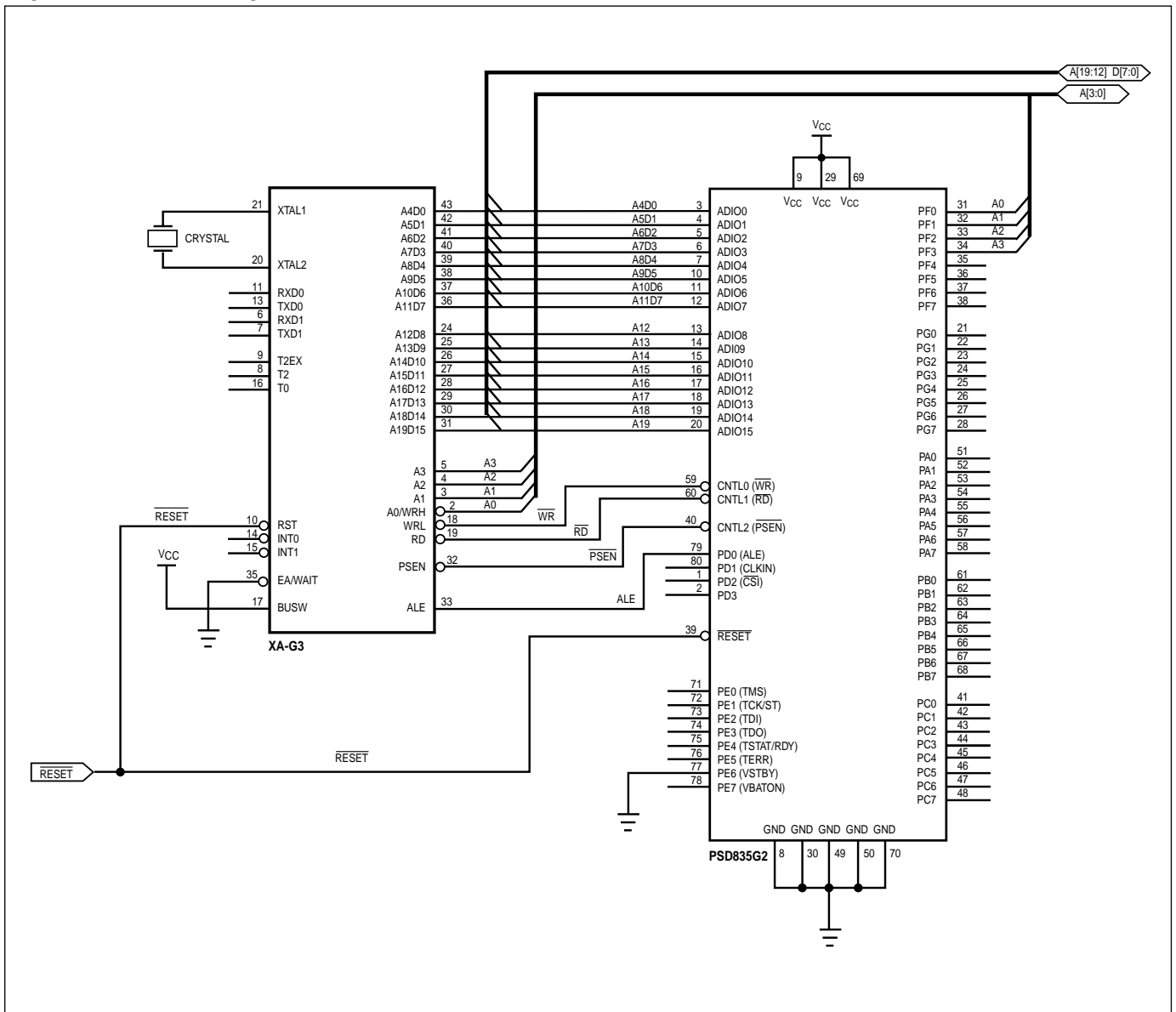
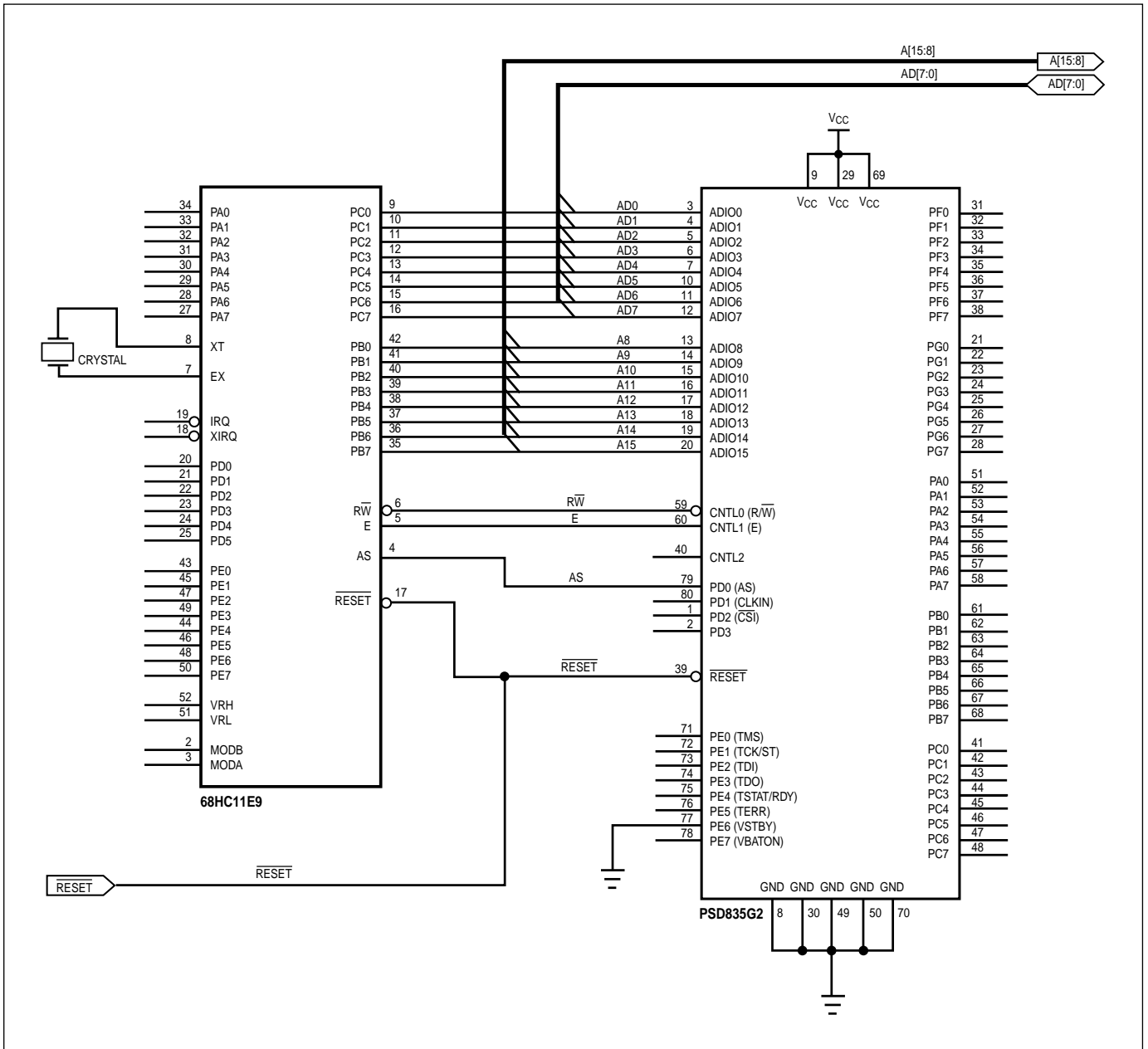

Figure 23. Interfacing the PSD835G2 with a 68HC11E9



## The PSD835G2 Functional Blocks (cont.)

### 9.4 I/O Ports

There are seven programmable I/O ports: Ports A, B, C, D, E, F and G. Each of the ports is eight bits except Port D, which is 4 bits. Each port pin is individually user configurable, thus allowing multiple functions per port. The ports are configured using PSDsoft or by the microcontroller writing to on-chip registers in the CSIOP address space.

The topics discussed in this section are:

- General Port Architecture
- Port Operating Modes
- Port Configuration Registers
- Port Data Registers
- Individual Port Functionality.

#### 9.4.1 General Port Architecture

The general architecture of the I/O Port is shown in Figure 24. Individual Port architectures are shown in Figures 26 through 28. In general, once the purpose for a port pin has been defined, that pin will no longer be available for other purposes. Exceptions will be noted.

As shown in Figure 24, the ports contain an output multiplexer whose selects are driven by the configuration bits in the Control Registers (Ports E, F and G only) and PSDsoft Configuration. Inputs to the multiplexer include the following:

- Output data from the Data Out Register
- Latched address outputs
- CPLD Micro $\leftrightarrow$ Cell output
- External Chip Select from CPLD.

The Port Data Buffer (PDB) is a tri-state buffer that allows only one source at a time to be read. The PDB is connected to the Internal Data Bus for feedback and can be read by the microcontroller. The Data Out and Micro $\leftrightarrow$ Cell outputs, Direction and Control Registers, and port pin input are all connected to the PDB.

The Port pin's tri-state output driver enable is controlled by a two input OR gate whose inputs come from the CPLD AND array enable product term and the Direction Register. If the enable product term of any of the array outputs are not defined and that port pin is not defined as a CPLD output in the PSDlabel file, then the Direction Register has sole control of the buffer that drives the port pin.

The contents of these registers can be altered by the microcontroller. The PDB feedback path allows the microcontroller to check the contents of the registers.

Ports A, B, and C have embedded Input Micro $\leftrightarrow$ Cells (IMCs). The IMCs can be configured as latches, registers, or direct inputs to the PLDs. The latches and registers are clocked by the address strobe (AS/ALE) or a product term from the PLD AND array. The outputs from the IMCs drive the PLD input bus and can be read by the microcontroller. Refer to the IMC subsection of the PLD section.

The  
PSD835G2  
Functional  
Blocks  
(cont.)

Figure 24. General I/O Port Architecture

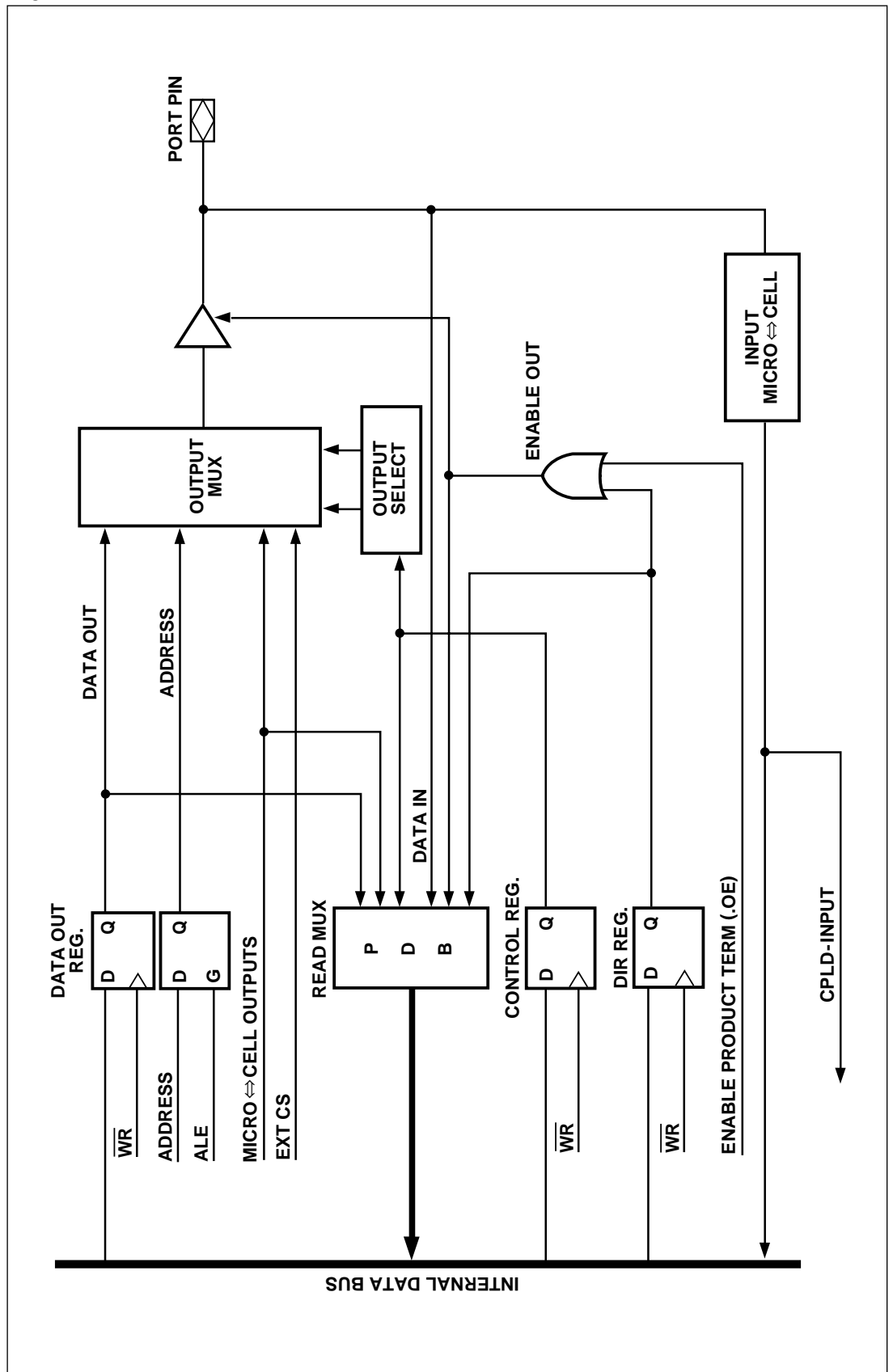

The  
PSD835G2  
Functional  
Blocks  
(cont.)

9.4.2 Port Operating Modes

The I/O Ports have several modes of operation. Some modes can be defined using PSDsoft, some by the microcontroller writing to the Registers in CSIOP space, and some by both. The modes that can only be defined using PSDsoft must be programmed into the device and cannot be changed unless the device is reprogrammed. The modes that can be changed by the microcontroller can be done so dynamically at run-time. The PLD I/O, Data Port, Address Input, Peripheral I/O and MCU Reset modes are the only modes that must be defined before programming the device. All other modes can be changed by the microcontroller at run-time.

Table 16 summarizes which modes are available on each port. Table 17 shows how and where the different modes are configured. Each of the port operating modes are described in the following subsections.

Table 16. Port Operating Modes

Port Mode	Port A	Port B	Port C	Port D	Port E	Port F	Port G
MCU I/O	Yes	Yes	Yes	Yes	Yes	Yes	Yes
PLD I/O							
McellA Outputs	Yes	No	No	No	No	No	No
McellB Outputs	No	Yes	No	No	No	No	No
Additional Ext. CS Outputs	No	No	Yes	No	No	Yes	No
PLD Inputs	Yes	Yes	Yes	Yes	No	Yes	No
Address Out	No	No	No	No	Yes (A7-0)	Yes (A7-0)	Yes (A7-0) or (A15-8)
Address In	Yes	Yes	Yes	Yes	No	Yes	No
Data Port	No	No	No	No	No	Yes	No
Peripheral I/O	No	No	No	No	No	Yes	No
JTAG ISP	No	No	No	No	Yes*	No	No

\*Can be multiplexed with other I/O functions.

The  
PSD835G2  
Functional  
Blocks  
(cont.)

Table 17. Port Operating Mode Settings

Mode	Defined In PSDsoft	Control Register Setting	Direction Register Setting	VM Register Setting	JTAG Enable
MCU I/O	Declare pins only	0 (Note 3)	1 = output, 0 = input (Note 1)	NA	NA
PLD I/O	Declare pins and logic equations	NA	(Note 1)	NA	NA
Data Port (Port F)	Selected for MCU with non-mux bus	NA	NA	NA	NA
Address Out (Port E, F, G)	Declare pins only	1	1 (Note 1)	NA	NA
Address In (Port A,B,C,D,F)	Declare pins or logic equation for input Micro $\leftrightarrow$ Cells	NA	NA	NA	NA
Peripheral I/O (Port F)	Logic equations (PSEL0 & 1)	NA	NA	PIO bit = 1	NA
JTAG ISP (Note 2)	Declare pins only	NA	NA	NA	JTAG_Enable

\*NA = Not Applicable

- NOTE:** 1. The direction of the Port A,B,C, and F pins are controlled by the Direction Register ORed with the individual output enable product term (.oe) from the CPLD AND array.  
2. Any of these three methods will enable JTAG pins on Port E.  
3. Control Register setting is not applicable to Ports A, B and C.

#### 9.4.2.1 MCU I/O Mode

In the MCU I/O Mode, the microcontroller uses the PSD835G2 ports to expand its own I/O ports. By setting up the CSIOP space, the ports on the PSD4000 are mapped into the microcontroller address space. The addresses of the ports are listed in Table 6.

A port pin can be put into MCU I/O mode by writing a '0' to the corresponding bit in the Control Register (Port E, F and G). The MCU I/O direction may be changed by writing to the corresponding bit in the Direction Register, or by the output enable product term. See the subsection on the Direction Register in the "Port Registers" section. When the pin is configured as an output, the content of the Data Out Register drives the pin. When configured as an input, the microcontroller can read the port input through the Data In buffer. See Figure 22.

Ports A, B and C do not have Control Registers, and are in MCU I/O mode by default. They can be used for PLD I/O if they are specified in PSDsoft.

#### 9.4.2.2 PLD I/O Mode

The PLD I/O Mode uses a port as an input to the CPLD's Input Micro $\leftrightarrow$ Cells, and/or as an output from the CPLD's Output Micro $\leftrightarrow$ Cells. The output can be tri-stated with a control signal. This output enable control signal can be defined by a product term from the PLD, or by setting the corresponding bit in the Direction Register to '0'. The corresponding bit in the Direction Register must not be set to '1' if the pin is defined as a PLD input pin in PSDsoft. The PLD I/O Mode is specified in PSDsoft by declaring the port pins, and then specifying an equation in PSDsoft.

The  
PSD835G2  
Functional  
Blocks  
(cont.)

#### 9.4.2.3 Address Out Mode

For microcontrollers with a multiplexed address/data bus, Address Out Mode can be used to drive latched addresses onto the port pins. These port pins can, in turn, drive external devices. Either the output enable or the corresponding bits of both the Direction Register and Control Register must be set to a '1' for pins to use Address Out Mode. This must be done by the MCU at run-time. See Table 18 for the address output pin assignments on Ports E, F and F for various MCUs.

**Note:** Do not drive address lines with Address Out Mode to an external memory device if it is intended for the MCU to boot from the external device. The MCU must first boot from PSD memory so the Direction and Control register bits can be set.

Table 18. I/O Port Latched Address Output Assignments

MCU	Port E (3:0)	Port E (7:4)	Port F (3:0)	Port F (7:4)	Port G (3:0)	Port G (7:4)
80C51XA	N/A*	Addr (7:4)	N/A*	Addr (7:4)	Addr (11:8)	N/A
80C251 (Page Mode)	N/A	N/A	N/A	N/A	Addr (11:8)	Addr (15:12)
All Other Eight-Bit Multiplexed	Addr (3:0)	Addr (7:4)	Addr (3:0)	Addr (7:4)	Addr (3:0)	Addr (7:4)
8-Bit Non-Mux Bus	N/A	N/A	N/A	N/A	Addr (3:0)	Addr (7:4)

#### 9.4.2.4 Address In Mode

For microcontrollers that have more than 16 address lines, the higher addresses can be connected to Ports A, B, C, D or F and are routed as inputs to the PLDs. The address input can be latched in the Input Micro $\leftrightarrow$ Cell by the address strobe (ALE/AS). Any input that is included in the DPLD equations for the Main Flash, Boot Flash, or SRAM is considered to be an address input.

#### 9.4.2.5 Data Port Mode

Port F can be used as a data bus port for a microcontroller with a non-multiplexed address/data bus. The Data Port is connected to the data bus of the microcontroller. The general I/O functions are disabled in Port F if the ports are configured as Data Port. Data Port Mode is automatically configured in PSDsoft when a non-multiplexed bus MCU is selected.

#### 9.4.2.6 Peripheral I/O Mode

Peripheral I/O Mode can be used to interface with external 8-bit peripherals. In this mode, all of Port F serves as a tri-stateable, bi-directional data buffer for the microcontroller. Peripheral I/O Mode is enabled by setting Bit 7 of the VM Register to a '1'. Figure 25 shows how Port A acts as a bi-directional buffer for the microcontroller data bus if Peripheral I/O Mode is enabled. An equation for PSEL0 and/or PSEL1 must be specified in PSDsoft. The buffer is tri-stated when PSEL 0 or 1 is not active.

#### 9.4.2.7 JTAG ISP

Port E is JTAG compliant, and can be used for In-System Programming (ISP). You can multiplex JTAG operations with other functions on Port E because ISP is not performed during normal system operation. For more information on the JTAG Port, refer to section 9.6.

The  
PSD835G2  
Functional  
Blocks  
(cont.)

Figure 25. Peripheral I/O Mode

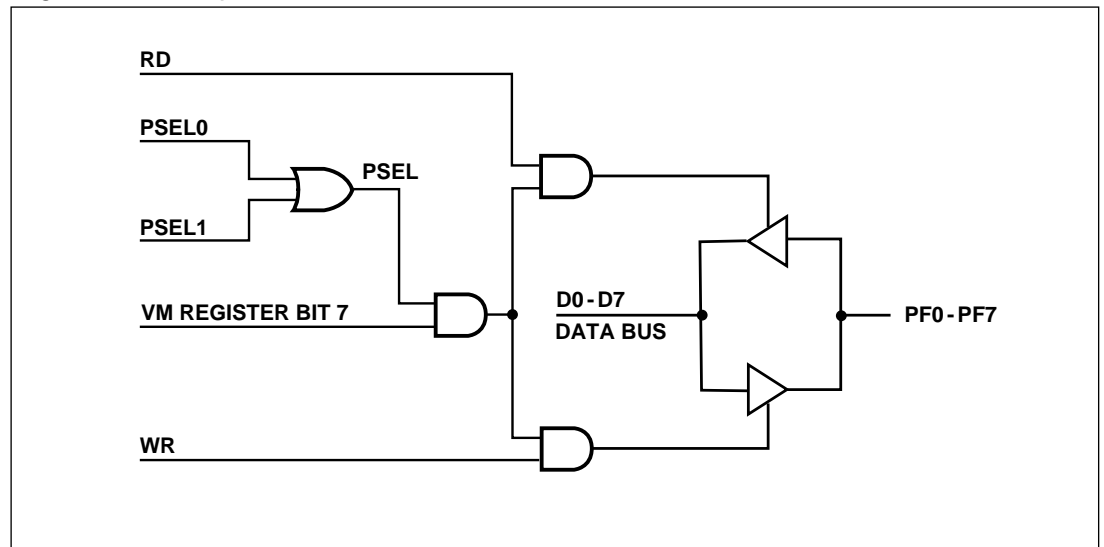

#### 9.4.3 Port Configuration Registers (PCRs)

Each port has a set of PCRs used for configuration. The contents of the registers can be accessed by the microcontroller through normal read/write bus cycles at the addresses given in Table 6. The addresses in Table 6 are the offsets in hex from the base of the CSIOP register.

The pins of a port are individually configurable and each bit in the register controls its respective pin. For example, Bit 0 in a register refers to Bit 0 of its port. The three PCRs, shown in Table 22, are used for setting the port configurations. The default power-up state for each register in Table 19 is 00h.

Table 19. Port Configuration Registers

Register Name	Port	MCU Access
Control	E,F,G	Write/Read
Direction	A,B,C,D,E,F,G	Write/Read
Drive Select*	A,B,C,D,E,F,G	Write/Read

\*NOTE: See Table 26 for Drive Register bit definition.

The PSD835G2 Functional Blocks (cont.)

9.4.3.1 Control Register

Any bit set to '0' in the Control Register sets the corresponding Port pin to MCU I/O Mode, and a '1' sets it to Address Out Mode. The default mode is MCU I/O. Only Ports E, F and G have an associated Control Register.

9.4.3.2 Direction Register

The Direction Register controls the direction of data flow in the I/O Ports. Any bit set to '1' in the Direction Register will cause the corresponding pin to be an output, and any bit set to '0' will cause it to be an input. The default mode for all port pins is input.

Figures 26 and 28 show the Port Architecture diagrams for Ports A/B/C and E/F/G respectively. The direction of data flow for Ports A, B, C and F are controlled not only by the direction register, but also by the output enable product term from the PLD AND array. If the output enable product term is not active, the Direction Register has sole control of a given pin's direction.

An example of a configuration for a port with the three least significant bits set to output and the remainder set to input is shown in Table 22. Since Port D only contains four pins, the Direction Register for Port D has only the four least significant bits active.

Table 20. Port Pin Direction Control, Output Enable P.T. Not Defined

Direction Register Bit	Port Pin Mode
0	Input
1	Output

Table 21. Port Pin Direction Control, Output Enable P.T. Defined

Direction Register Bit	Output Enable P.T.	Port Pin Mode
0	0	Input
0	1	Output
1	0	Output
1	1	Output

Table 22. Port Direction Assignment Example

Bit 7	Bit 6	Bit 5	Bit 4	Bit 3	Bit 2	Bit 1	Bit 0
0	0	0	0	0	1	1	1

## The PSD835G2 Functional Blocks

(cont.)

### 9.4.3.3 Drive Select Register

The Drive Select Register configures the pin driver as Open Drain or CMOS for some port pins, and controls the slew rate for the other port pins. An external pull-up resistor should be used for pins configured as Open Drain.

A pin can be configured as Open Drain if its corresponding bit in the Drive Select Register is set to a '1'. The default pin drive is CMOS.

**Aside:** the slew rate is a measurement of the rise and fall times of an output. A higher slew rate means a faster output response and may create more electrical noise. A pin operates in a high slew rate when the corresponding bit in the Drive Register is set to '1'. The default rate is slow slew.

Table 23 shows the Drive Register for Ports A, B, C, D, E, F and G. It summarizes which pins can be configured as Open Drain outputs and which pins the slew rate can be set for.

Table 23. Drive Register Pin Assignment

Drive Register	Bit 7	Bit 6	Bit 5	Bit 4	Bit 3	Bit 2	Bit 1	Bit 0
Port A	Open Drain	Open Drain	Open Drain	Open Drain	Open Drain	Open Drain	Open Drain	Open Drain
Port B	Open Drain	Open Drain	Open Drain	Open Drain	Open Drain	Open Drain	Open Drain	Open Drain
Port C	Slew Rate	Slew Rate	Slew Rate	Slew Rate	Slew Rate	Slew Rate	Slew Rate	Slew Rate
Port D					Open Drain	Open Drain	Open Drain	Open Drain
Port E	Open Drain	Open Drain	Open Drain	Open Drain	Open Drain	Open Drain	Open Drain	Open Drain
Port F	Slew Rate	Slew Rate	Slew Rate	Slew Rate	Slew Rate	Slew Rate	Slew Rate	Slew Rate
Port G	Open Drain	Open Drain	Open Drain	Open Drain	Open Drain	Open Drain	Open Drain	Open Drain

The  
PSD835G2  
Functional  
Blocks  
(cont.)

#### 9.4.4 Port Data Registers

The Port Data Registers, shown in Table 24, are used by the microcontroller to write data to or read data from the ports. Table 24 shows the register name, the ports having each register type, and microcontroller access for each register type. The registers are described below.

##### 9.4.4.1 Data In

Port pins are connected directly to the Data In buffer. In MCU I/O input mode, the pin input is read through the Data In buffer.

##### 9.4.4.2 Data Out Register

Stores output data written by the MCU in the MCU I/O output mode. The contents of the Register are driven out to the pins if the Direction Register or the output enable product term is set to "1". The contents of the register can also be read back by the microcontroller.

##### 9.4.4.3 Output Micro $\leftrightarrow$ Cells (OMCs)

The CPLD OMCs occupy a location in the microcontroller's address space. The microcontroller can read the output of the OMCs. If the Mask Micro $\leftrightarrow$ Cell Register bits are not set, writing to the Micro $\leftrightarrow$ Cell loads data to the Micro $\leftrightarrow$ Cell flip flops. Refer to the PLD section for more details.

##### 9.4.4.4 Mask Micro $\leftrightarrow$ Cell Register

Each Mask Register bit corresponds to an OMC flip flop. When the Mask Register bit is set to a "1", loading data into the OMC flip flop is blocked. The default value is "0" or unblocked.

##### 9.4.4.5 Input Micro $\leftrightarrow$ Cells (IMCs)

The IMCs can be used to latch or store external inputs. The outputs of the IMCs are routed to the PLD input bus, and can be read by the microcontroller. Refer to the PLD section for a detailed description.

##### 9.4.4.6 Enable Out

The Enable Out register can be read by the microcontroller. It contains the output enable values for a given port. A "1" indicates the driver is in output mode. A "0" indicates the driver is in tri-state and the pin is in input mode.

Table 24. Port Data Registers

Register Name	Port	MCU Access
Data In	A,B,C,D,E,F,G	Read – input on pin
Data Out	A,B,C,D,E,F,G	Write/Read
Output Micro $\leftrightarrow$ Cell	A,B	Read – outputs of Micro $\leftrightarrow$ Cells Write – loading Micro $\leftrightarrow$ Cells Flip-Flop
Mask Micro $\leftrightarrow$ Cell	A,B	Write/Read – prevents loading into a given Micro $\leftrightarrow$ Cell
Input Micro $\leftrightarrow$ Cell	A,B,C	Read – outputs of the Input Micro $\leftrightarrow$ Cells
Enable Out	A,B,C,F	Read – the output enable control of the port driver

The PSD835G2 Functional Blocks (cont.)

9.4.5 Ports A, B and C – Functionality and Structure

Ports A and B have similar functionality and structure, as shown in Figure 26. The two ports can be configured to perform one or more of the following functions:

- ❑ MCU I/O Mode
- ❑ CPLD Output – Micro⇔Cells McellA[7:0] can be connected to Port A. McellB[7:0] can be connected to Port B. External chip select ECS [7:0] can be connected to Port C.
- ❑ CPLD Input – Via the input Micro⇔Cells.
- ❑ Address In – Additional high address inputs using the Input Micro⇔Cells.
- ❑ Open Drain/Slew Rate – pins PC[7:0] can be configured to fast slew rate, pins PA[7:0] and PB[7:0] can be configured to Open Drain Mode.

Figure 26. Port A, B and C

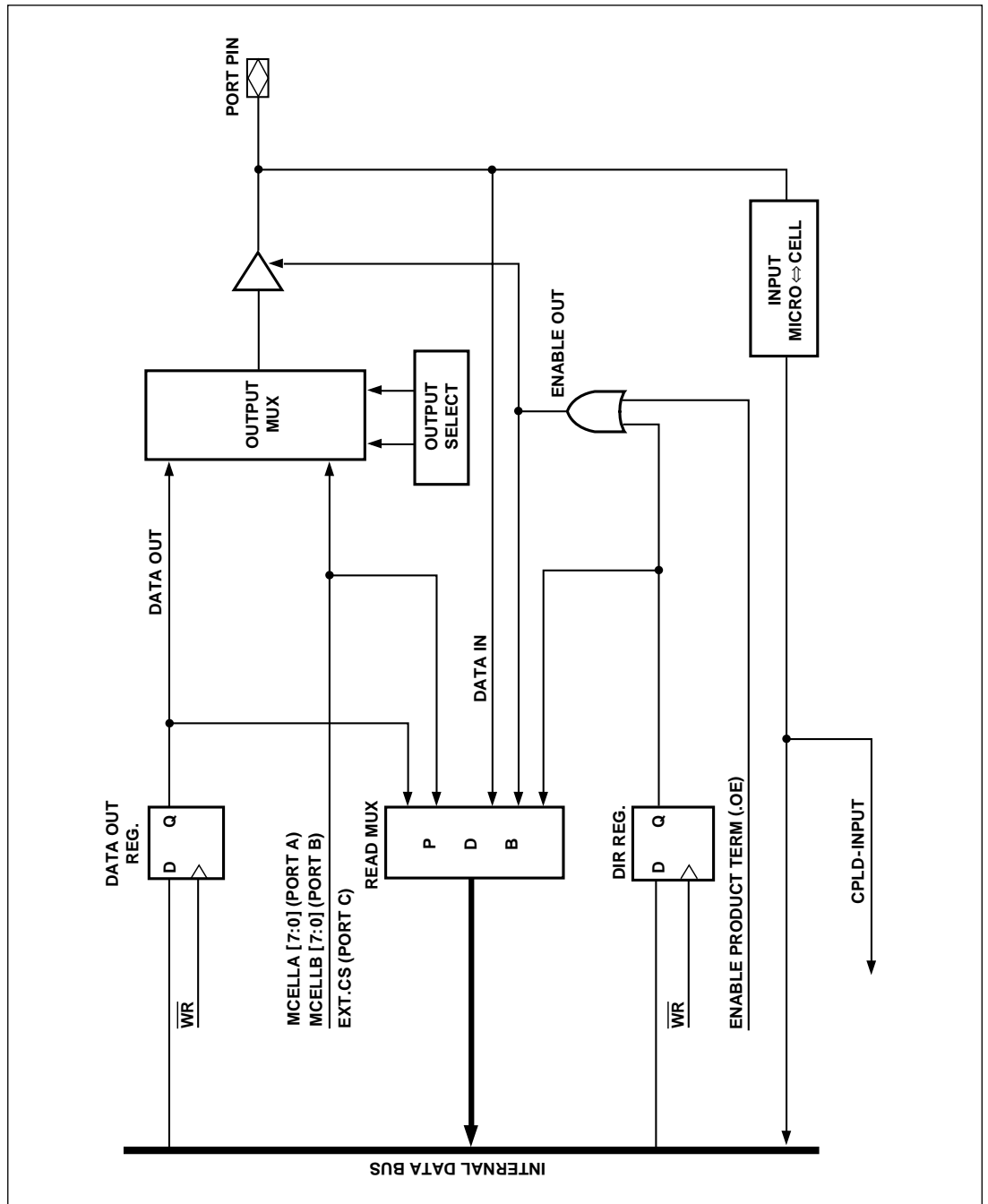

The PSD835G2 Functional Blocks (cont.)

9.4.6 Port D – Functionality and Structure

Port D has four I/O pins. See Figure 27. Port D can be configured to program one more of the following functions:

- MCU I/O Mode
- CPLD Input – direct input to CPLD, no Input Micro⇌Cells

Port D pins can be configured in PSDsoft as input pins for other dedicated functions:

- PD0 – ALE, as address strobe input
- PD1 – CLKIN, as clock input to the Micro⇌Cells Flip Flops and APD counter
- PD2 – CSI, as active low chip select input. A high input will disable the Flash/SRAM and CSIOP.
- PD3 – as DBE input from 68HC912

9.4.7 Port E – Functionality and Structure

Port E can be configured to perform one or more of the following functions (see Figure 28):

- MCU I/O Mode
- In-System Programming – JTAG port can be enabled for programming/erase of the PSD8XX device. (See Section 9.6 for more information on JTAG programming.)
- Open Drain – Port E pins can be configured in Open Drain Mode
- Battery Backup features – PE6 can be configured as a Battery Input (Vstby) pin. PE7 can be configured as a Battery On Indicator output pin, indicating when Vcc is less than Vbat.
- Latched Address Output – Provided latched address (A7-0) output

Figure 27. Port D Structure

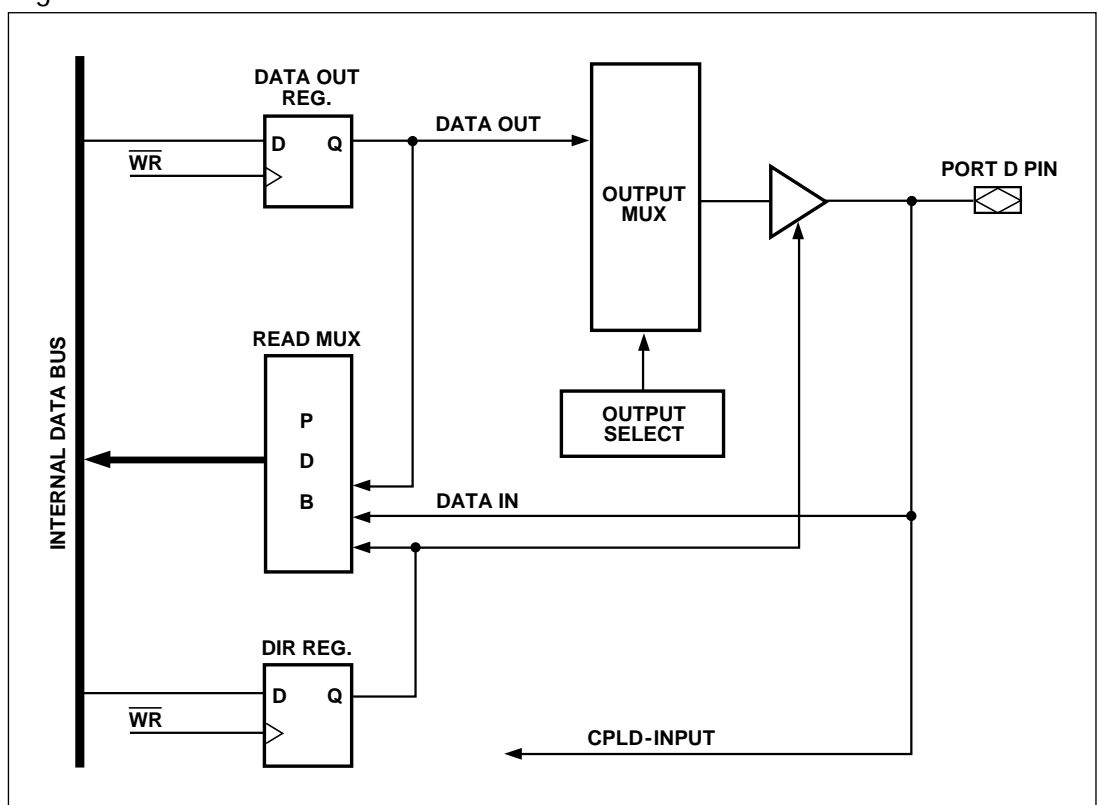

The  
PSD4000  
Functional  
Blocks  
(cont.)

### 9.4.8 Port F – Functionality and Structure

Port F can be configured to perform one or more of the following functions:

- MCU I/O Mode
- CPLD Output – external chip select ECS[7:0] can be connected to Port F (or Port C).
- CPLD Input – as direct input of the CPLD array.
- Address In – additional high address inputs. Direct input to the CPLD array, no Input Micro↔Cells latching is available.
- Latched Address Out – Provide latched address out per Table 29.
- Slew Rate – pins can be set up for fast slew rate.
- Data Port – connected to D[7:0] when Port F is configured as Data Port for a non-multiplexed bus.
- Peripheral I/O Mode

### 9.4.9 Port G – Functionality and Structure

Port G can be configured to perform one or more of the following functions:

- MCU I/O Mode
- Latched Address Out – provide latched address out per Table 29.
- Open Drain – pins can be configured in Open Drain Mode

Figure 28. Ports E, F and G Structure

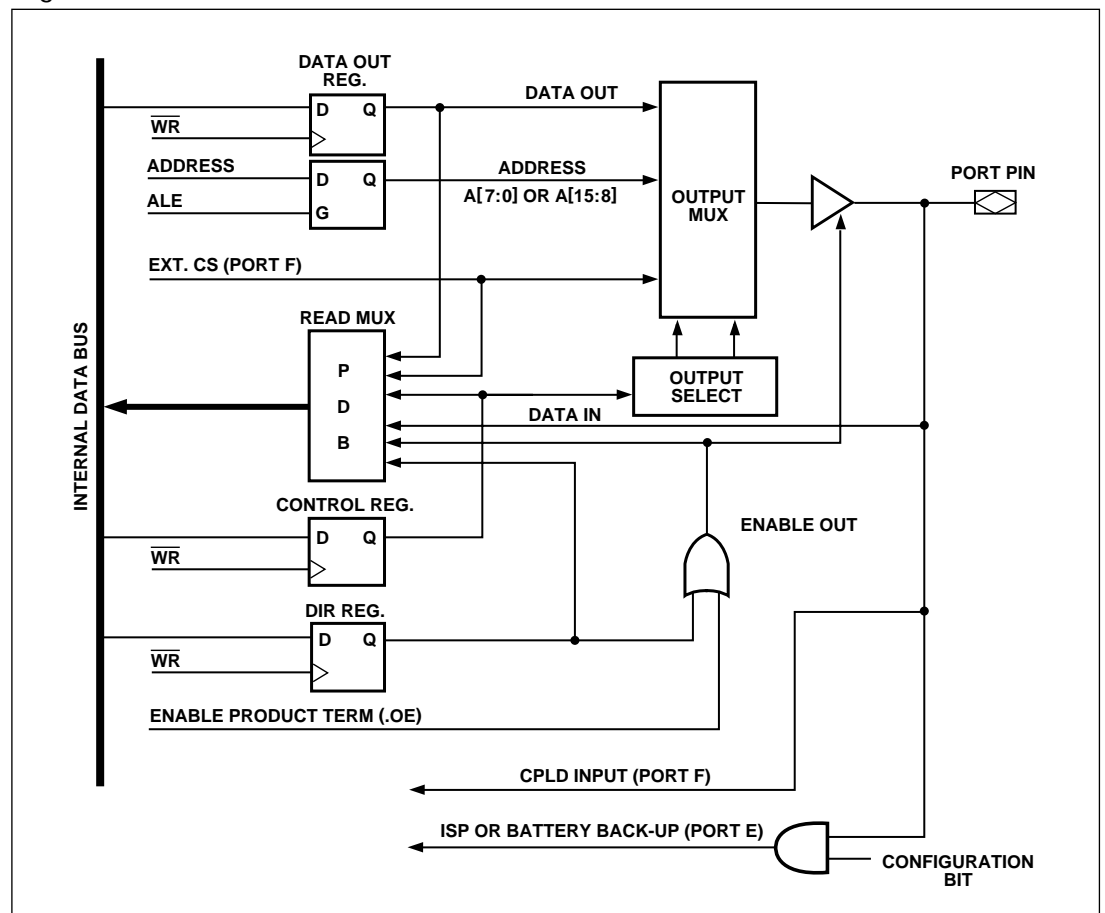

## The PSD835G2 Functional Blocks (cont.)

### 9.5 Power Management

The PSD835G2 offers configurable power saving options. These options may be used individually or in combinations, as follows:

- ❑ All memory types in a PSD (Flash, Secondary Flash, and SRAM) are built with Zero-Power technology. In addition to using special silicon design methodology, Zero-Power technology puts the memories into standby mode when address/data inputs are not changing (zero DC current). As soon as a transition occurs on an input, the affected memory “wakes up”, changes and latches its outputs, then goes back to standby. The designer does **not** have to do anything special to achieve memory standby mode when no inputs are changing—it happens automatically.

The PLD sections can also achieve standby mode when its inputs are not changing, see PMMR registers below.

- ❑ Like the Zero-Power feature, the Automatic Power Down (APD) logic allows the PSD to reduce to standby current automatically. The APD will block MCU address/data signals from reaching the memories and PLDs. This feature is available on all PSD835G2 devices. The APD unit is described in more detail in section 9.5.1.

Built in logic will monitor the address strobe of the MCU for activity. If there is no activity for a certain time period (MCU is asleep), the APD logic initiates Power Down Mode (if enabled). Once in Power Down Mode, all address/data signals are blocked from reaching PSD memories and PLDs, and the memories are deselected internally. This allows the memories and PLDs to remain in standby mode even if the address/data lines are changing state externally (noise, other devices on the MCU bus, etc.). Keep in mind that any unblocked PLD input signals that are changing states keeps the PLD out of standby mode, but not the memories.

- ❑ The PSD Chip Select Input (CSI) can be used to disable the internal memories, placing them in standby mode even if inputs are changing. This feature does not block any internal signals or disable the PLDs. This is a good alternative to using the APD logic, especially if your MCU has a chip select output. There is a slight penalty in memory access time when the CSI signal makes its initial transition from deselected to selected.
- ❑ The PMMR registers can be written by the MCU at run-time to manage power. All PSD devices support “blocking bits” in these registers that are set to block designated signals from reaching both PLDs. Current consumption of the PLDs is directly related to the composite frequency of the changes on their inputs (see Figures 32 and 32a). Significant power savings can be achieved by blocking signals that are not used in PLD logic equations at run time. PSDsoft creates a fuse map that automatically blocks the low address byte (A7-A0) or the control signals (CNTL0-2, ALE and WRH/DBE) if none of these signals are used in PLD logic equations.

The PSD835G2 devices have a Turbo Bit in the PMMR0 register. This bit can be set to disable the Turbo Mode feature (default is Turbo Mode on). While Turbo Mode is disabled, the PLDs can achieve standby current when no PLD inputs are changing (zero DC current). Even when inputs do change, significant power can be saved at lower frequencies (AC current), compared to when Turbo Mode is enabled. Conversely, when the Turbo Mode is enabled, there is a significant DC current component and the AC component is higher.

#### 9.5.1 Automatic Power Down (APD) Unit and Power Down Mode

The APD Unit, shown in Figure 24, puts the PSD into Power Down Mode by monitoring the activity of the address strobe (ALE/AS). If the APD unit is enabled, as soon as activity on the address strobe stops, a four bit counter starts counting. If the address strobe remains inactive for fifteen clock periods of the CLKIN signal, the Power Down (PDN) signal becomes active, and the PSD will enter into Power Down Mode, discussed next.

## The PSD835G2 Functional Blocks (cont.)

### 9.5.1 Automatic Power Down (APD) Unit and Power Down Mode (cont.)

#### Power Down Mode

By default, if you enable the PSD APD unit, Power Down Mode is automatically enabled. The device will enter Power Down Mode if the address strobe (ALE/AS) remains inactive for fifteen CLKIN (pin PD1) clock periods.

The following should be kept in mind when the PSD is in Power Down Mode:

- If the address strobe starts pulsing again, the PSD will return to normal operation. The PSD will also return to normal operation if either the CSI input returns low or the Reset input returns high.
- The MCU address/data bus is blocked from all memories and PLDs.
- Various signals can be blocked (prior to Power Down Mode) from entering the PLDs by setting the appropriate bits in the PMMR registers. The blocked signals include MCU control signals and the common clock (CLKIN). Note that blocking CLKIN from the PLDs will not block CLKIN from the APD unit.
- All PSD memories enter Standby Mode and are drawing standby current. However, the PLDs and I/O ports do **not** go into Standby Mode because you don't want to have to wait for the logic and I/O to "wake-up" before their outputs can change. See Table 25 for Power Down Mode effects on PSD ports.
- Typical standby current is 50  $\mu\text{A}$  for 5 V parts. This standby current value assumes that there are no transitions on any PLD input.

Table 25. Power Down Mode's Effect on Ports

Port Function	Pin Level
MCU I/O	No Change
PLD Out	No Change
Address Out	Undefined
Data Port	Three-State
Peripheral I/O	Three-State

Table 26. PSD835G2 Timing and Standby Current During Power Down Mode

Mode	PLD Propagation Delay	Memory Access Time	Access Recovery Time to Normal Access	5V $V_{CC}$ , Typical Standby Current
Power Down	Normal t <sub>pd</sub> (Note 1)	No Access	t <sub>LVDV</sub>	50 $\mu\text{A}$ (Note 2)

- NOTES:**
1. Power Down does not affect the operation of the PLD. The PLD operation in this mode is based only on the Turbo Bit.
  2. Typical current consumption assuming no PLD inputs are changing state and the PLD Turbo bit is off.

The PSD835G2 Functional Blocks (cont.)

Figure 29. APD Logic Block

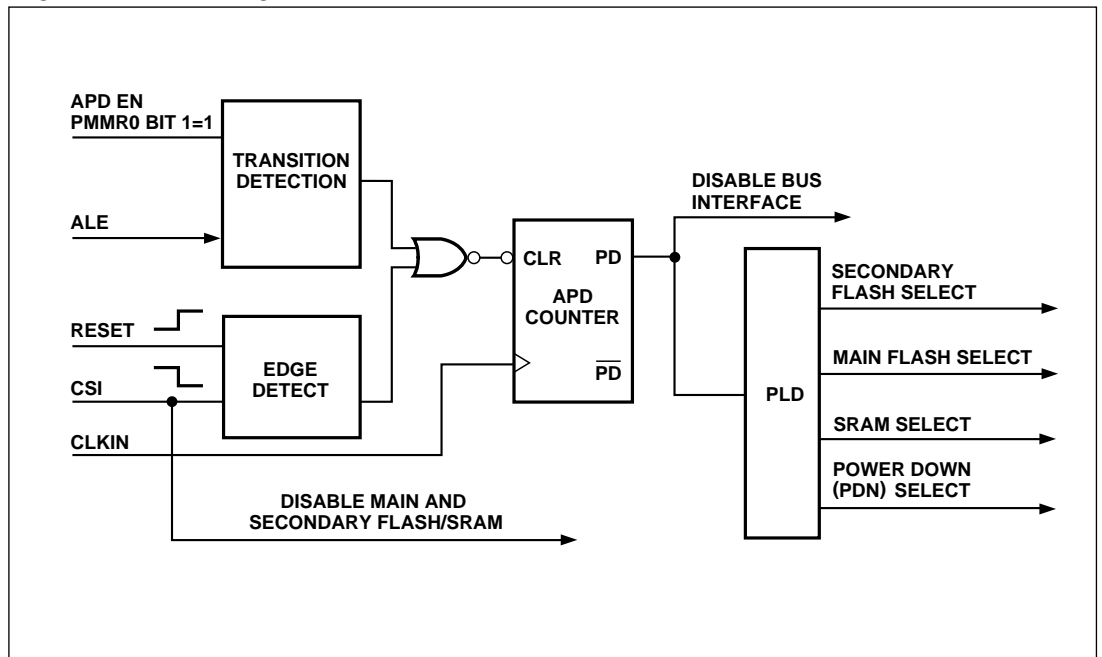
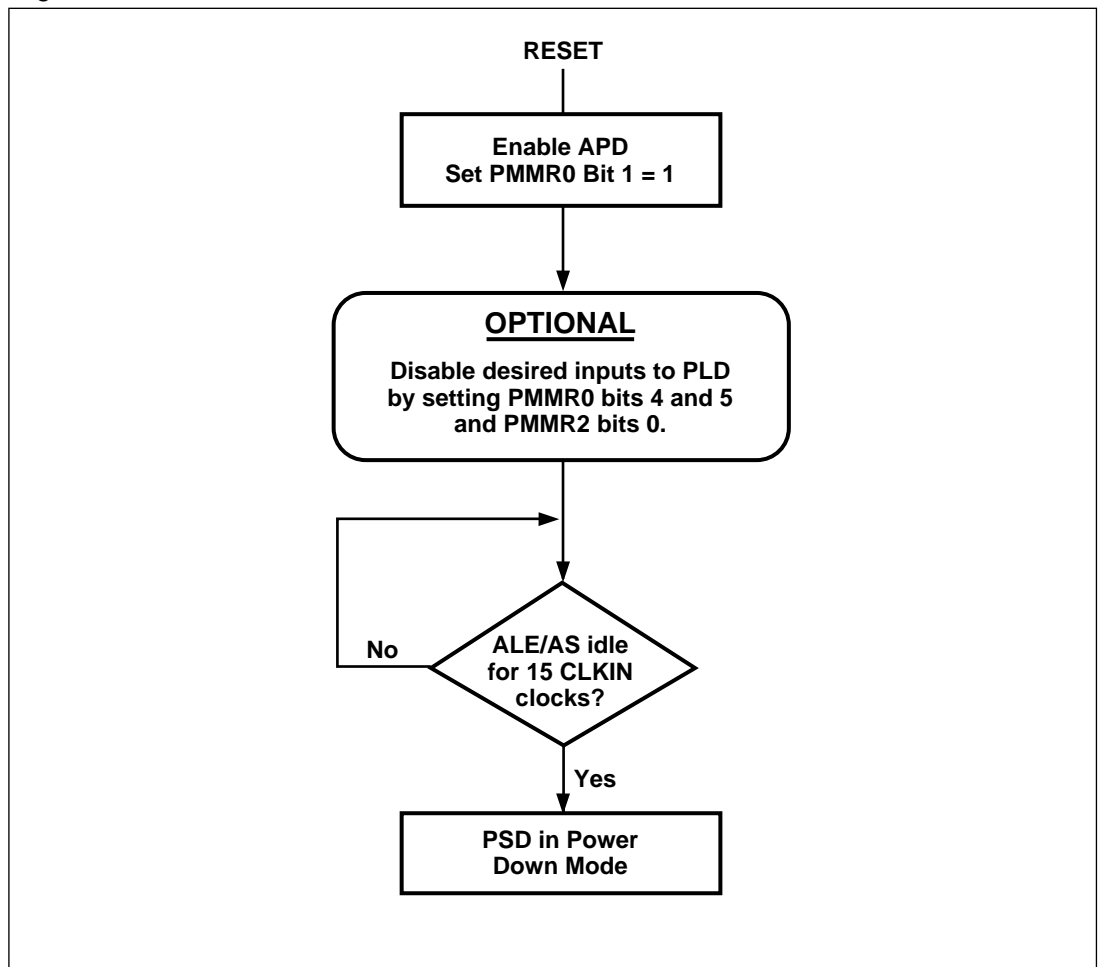

Figure 30. Enable Power Down Flow Chart



The  
PSD835G2  
Functional  
Blocks  
(cont.)

Table 27. Power Management Mode Registers (PMMR0, PMMR2)\*\*

## PMMR0

Bit 7	Bit 6	Bit 5	Bit 4	Bit 3	Bit 2	Bit 1	Bit 0
*	*	PLD Mcell clk	PLD Array clk	PLD Turbo	*	APD Enable	*
		1 = off	1 = off	1 = off		1 = on	

\*Bits 0, 2, 6, and 7 are not used, and should be set to 0.

\*\*The PMMR0, and PMMR2 register bits are cleared to zero following power up. Subsequent reset pulses will not clear the registers.

- Bit 1 0 = Automatic Power Down (APD) is disabled.  
1 = Automatic Power Down (APD) is enabled.
- Bit 3 0 = PLD Turbo is on.  
1 = PLD Turbo is off, saving power.
- Bit 4 0 = CLKIN input to the PLD AND array is connected.  
Every CLKIN change will power up the PLD when Turbo bit is off.  
1 = CLKIN input to PLD AND array is disconnected, saving power.
- Bit 5 0 = CLKIN input to the PLD Micro↔Cells is connected.  
1 = CLKIN input to PLD Micro↔Cells is disconnected, saving power.

## PMMR2

Bit 7	Bit 6	Bit 5	Bit 4	Bit 3	Bit 2	Bit 1	Bit 0
*	PLD array DBE	PLD array ALE	PLD** array CNTL2	PLD** array CNTL1	PLD** array CNTL0	*	PLD array Addr.
	1 = off	1 = off	1 = off	1 = off	1 = off		1 = off

\*Unused bits should be set to 0.

\*\*Refer to Table 14 the signals that are blocked on pins CNTL0-2.

- Bit 0 0 = Address A[7:0] inputs to the PLD AND array are connected.  
1 = Address A[7:0] inputs to the PLD AND array are disconnected, saving power.  
**Note:** In 80C51 mode, A[7:1] comes from Port F (PF1-PF3) and AD10 [3:0].
- Bit 2 0 = Cntl0 input to the PLD AND array is connected.  
1 = Cntl0 input to PLD AND array is disconnected, saving power.
- Bit 3 0 = Cntl1 input to the PLD AND array is connected.  
1 = Cntl1 input to PLD AND array is disconnected, saving power.
- Bit 4 0 = Cntl2 input to the PLD AND array is connected.  
1 = Cntl2 input to PLD AND array is disconnected, saving power.
- Bit 5 0 = ALE input to the PLD AND array is connected.  
1 = ALE input to PLD AND array is disconnected, saving power.
- Bit 6 0 = DBE input to the PLD AND array is connected.  
1 = DBE input to PLD AND array is disconnected, saving power.

Table 28. APD Counter Operation

APD Enable Bit	ALE PD Polarity	ALE Level	APD Counter
0	X	X	Not Counting
1	X	Pulsing	Not Counting
1	1	1	Counting (Generates PDN after 15 Clocks)
1	0	0	Counting (Generates PDN after 15 Clocks)

### 9.5.2 Other Power Saving Options

The PSD835G2 offers other reduced power saving options that are independent of the Power Down Mode. Except for the SRAM Standby and CSI input features, they are enabled by setting bits in the PMMR0 and PMMR2 registers.

#### 9.5.2.1 Zero Power PLD

The power and speed of the PLDs are controlled by the Turbo bit (bit 3) in the PMMR0. By setting the bit to “1”, the Turbo mode is disabled and the PLDs consume Zero Power current when the inputs are not switching for an extended time of 70 ns. The propagation delay time will be increased after the Turbo bit is set to “1” (turned off) when the inputs change at a composite frequency of less than 15 MHz. When the Turbo bit is set to a “0” (turned on), the PLDs run at full power and speed. The Turbo bit affects the PLD’s D.C. power, AC power, and propagation delay. Refer to AC/DC spec for PLD timings.

**Note:** Blocking MCU control signals with PMMR2 bits can further reduce PLD AC power consumption.

#### 9.5.2.2 SRAM Standby Mode (Battery Backup)

The PSD835G2 supports a battery backup operation that retains the contents of the SRAM in the event of a power loss. The SRAM has a Vstby pin (PE6) that can be connected to an external battery. When  $V_{CC}$  becomes lower than Vstby then the PSD will automatically connect to Vstby as a power source to the SRAM. The SRAM Standby Current (Istby) is typically 0.5  $\mu$ A. The SRAM data retention voltage is 2 V minimum. The battery-on indicator (Vbaton) can be routed to PE7. This signal indicates when the  $V_{CC}$  has dropped below the Vstby voltage and that the SRAM is running on battery power.

#### 9.5.2.3 The CSI Input

Pin PD2 of Port D can be configured in PSDsoft as the CSI input. When low, the signal selects and enables the internal Flash, Boot Block, SRAM, and I/O for read or write operations involving the PSD835G2. A high on the CSI pin will disable the Flash memory, Boot Block, and SRAM, and reduce the PSD power consumption. However, the PLD and I/O pins remain operational when CSI is high. **Note:** there may be a timing penalty when using the CSI pin depending on the speed grade of the PSD that you are using. See the timing parameter  $t_{SLQV}$  in the AC/DC specs.

#### 9.5.2.4 Input Clock

The PSD4000 provides the option to turn off the CLKIN input to the PLD to save AC power consumption. The CLKIN is an input to the PLD AND array and the Output Micro $\leftrightarrow$ Cells. During Power Down Mode, or, if the CLKIN input is not being used as part of the PLD logic equation, the clock should be disabled to save AC power. The CLKIN will be disconnected from the PLD AND array or the Micro $\leftrightarrow$ Cells by setting bits 4 or 5 to a “1” in PMMR0.

#### 9.5.2.5 MCU Control Signals

The PSD835G2 provides the option to turn off the address input (A7-0) and input control signals (CNTL0-2, ALE, and DBE) to the PLD to save AC power consumption. These signals are inputs to the PLD AND array. During Power Down Mode, or, if any of them are not being used as part of the PLD logic equation, these control signals should be disabled to save AC power. They will be disconnected from the PLD AND array by setting bits 0, 2, 3, 4, 5, and 6 to a “1” in the PMMR2.

The  
PSD835G2  
Functional  
Blocks  
(cont.)

### 9.5.3 Reset and Power On Requirement

#### 9.5.3.1 Power On Reset

Upon power up the PSD835G2 requires a reset pulse of  $t_{NLNH-PO}$  (minimum 1 ms) after  $V_{CC}$  is steady. During this time period the device loads internal configurations, clears some of the registers and sets the Flash into operating mode. After the rising edge of reset, the PSD835G2 remains in the reset state for an additional  $t_{OPR}$  (maximum 120 ns) nanoseconds before the first memory access is allowed.

The PSD835G2 Flash memory is reset to the read array mode upon power up. The  $FSi$  and  $CSBOOTi$  select signals along with the write strobe signal must be in the false state during power-up reset for maximum security of the data contents and to remove the possibility of data being written on the first edge of a write strobe signal. Any Flash memory write cycle initiation is prevented automatically when  $V_{CC}$  is below  $V_{LKO}$ .

#### 9.5.3.2 Warm Reset

Once the device is up and running, the device can be reset with a much shorter pulse of  $t_{NLNH}$  (minimum 150 ns). The same  $t_{OPR}$  time is needed before the device is operational after warm reset. Figure 31 shows the timing of the power on and warm reset.

Figure 31. Power On and Warm Reset Timing

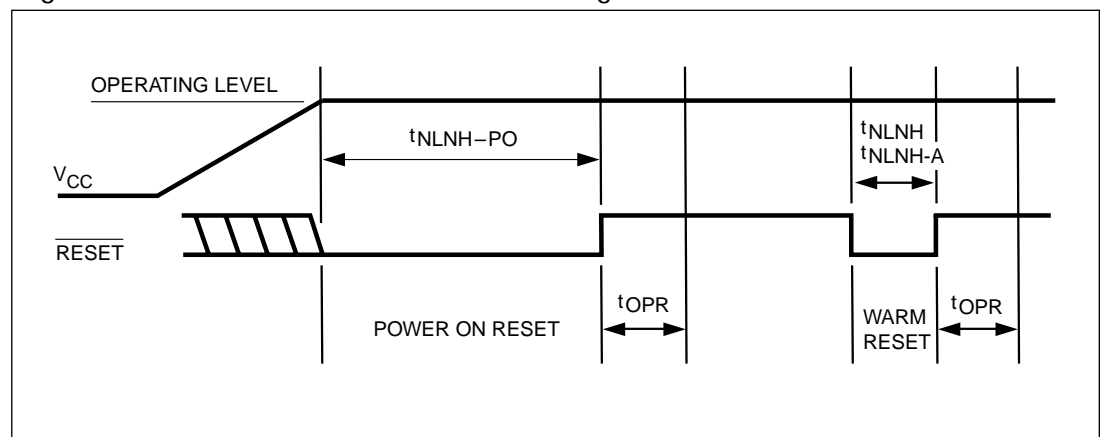

#### 9.5.3.3 I/O Pin, Register and PLD Status at Reset

Table 29 shows the I/O pin, register and PLD status during power on reset, warm reset and power down mode. PLD outputs are always valid during warm reset, and they are valid in power on reset once the internal PSD configuration bits are loaded. This loading of PSD is completed typically long before the  $V_{CC}$  ramps up to operating level. Once the PLD is active, the state of the outputs are determined by the equations specified in PSDsoft.

The  
PSD835G2  
Functional  
Blocks  
(cont.)

Table 29. Status During Power On Reset, Warm Reset and Power Down Mode

Port Configuration	Power On Reset	Warm Reset	Power Down Mode
MCU I/O	Input Mode	Input Mode	Unchanged
PLD Output	Valid after internal PSD configuration bits are loaded	Valid	Depend on inputs to PLD (address are blocked in PD mode)
Address Out	Tri-stated	Tri-stated	Not defined
Data Port	Tri-stated	Tri-stated	Tri-stated
Peripheral I/O	Tri-stated	Tri-stated	Tri-stated

Register	Power On Reset	Warm Reset	Power Down Mode
PMMR0, 2	Cleared to "0"	Unchanged	Unchanged
Micro $\leftrightarrow$ Cells Flip Flop status	Cleared to "0" by internal power on reset	Depend on .re and .pr equations	Depend on .re and .pr equations
VM Register*	Initialized based on the selection in PSDsoft Configuration Menu.	Initialized based on the selection in PSDsoft Configuration Menu.	Unchanged
All other registers	Cleared to "0"	Cleared to "0"	Unchanged

\*SR\_cod and Periph Mode bits in the VM Register are always cleared to zero on power on or warm reset.

#### 9.5.3.4 Reset of Flash Erase and Programming Cycles

An external reset on the RESET pin will also reset the internal Flash memory state machine. When the Flash is in programming or erase mode, the RESET pin will terminate the programming or erase operation and return the Flash back to read mode in tNLNH-A (minimum 25  $\mu$ s) time.

## 9.6 Programming In-Circuit using the JTAG-ISP Interface

The JTAG-ISP interface on the PSD835G2 can be enabled on Port E (see Table 30). All memory (Flash and Flash Boot Block), PLD logic, and PSD configuration bits may be programmed through the JTAG-ISC interface. A blank part can be mounted on a printed circuit board and programmed using JTAG-ISP.

The standard JTAG signals (IEEE 1149.1) are TMS, TCK, TDI, and TDO. Two additional signals, TSTAT and  $\overline{\text{TERR}}$ , are optional JTAG extensions used to speed up program and erase operations.

By default, on a blank PSD (as shipped from factory or after erasure), four pins on Port E are enabled for the basic JTAG signals TMS, TCK, TDI, and TDO.

See ST Application Note AN1153 for more details on JTAG In-System-Programming.

Table 30. JTAG Port Signals

Port E Pin	JTAG Signals	Description
PE0	TMS	Mode Select
PE1	TCK	Clock
PE2	TDI	Serial Data In
PE3	TDO	Serial Data Out
PE4	TSTAT	Status
PE5	$\overline{\text{TERR}}$	Error Flag

The  
PSD835G2  
Functional  
Blocks  
(cont.)

### 9.6.1 Standard JTAG Signals

The standard JTAG signals (TMS, TCK, TDI, and TDO) can be enabled by any of three different conditions that are logically ORed. When enabled, TDI, TDO, TCK, and TMS are inputs, waiting for a serial command from an external JTAG controller device (such as FlashLink or Automated Test Equipment). When the enabling command is received from the external JTAG controller, TDO becomes an output and the JTAG channel is fully functional inside the PSD. The same command that enables the JTAG channel may optionally enable the two additional JTAG pins, TSTAT and  $\overline{\text{TERR}}$ .

The following symbolic logic equation specifies the conditions enabling the four basic JTAG pins (TMS, TCK, TDI, and TDO) on their respective Port E pins. For purposes of discussion, the logic label JTAG\_ON will be used. When JTAG\_ON is true, the four pins are enabled for JTAG. When JTAG\_ON is false, the four pins can be used for general PSD I/O.

```
JTAG_ON = PSDsoft_enabled +
          /* An NVM configuration bit inside the PSD is set by the designer
           in the PSDsoft Configuration utility. This dedicates the pins for
           JTAG at all times (compliant with IEEE 1149.1) */

          Microcontroller_enabled +
          /* The microcontroller can set a bit at run-time by writing to the
           PSD register, JTAG Enable. This register is located at address
           CSIOP + offset C7h. Setting the JTAG_ENABLE bit in this
           register will enable the pins for JTAG use. This bit is cleared
           by a PSD reset or the microcontroller. See Table 31 for bit
           definition. */

          PSD_product_term_enabled;
          /* A dedicated product term (PT) inside the PSD can be used to
           enable the JTAG pins. This PT has the reserved name
           JTAGSEL. Once defined as a node in PSDabel, the designer
           can write an equation for JTAGSEL. This method is used when
           the Port E JTAG pins are multiplexed with other I/O signals.
           It is recommended to logically tie the node JTAGSEL to the
           JEN\ signal on the Flashlink cable when multiplexing JTAG
           signals. See Application Note 54 for details.
```

Table 31. JTAG Enable Register

JTAG Enable

Bit 7	Bit 6	Bit 5	Bit 4	Bit 3	Bit 2	Bit 1	Bit 0
*	*	*	*	*	*	*	JTAG_ENABLE

\*Bits 1-7 are not used and should set to 0.

Bit definitions:

JTAG\_ENABLE 1 = JTAG Port is Enabled.  
0 = JTAG Port is Disabled.

**NOTE:**

The state of the PSD reset input signal will not interrupt (or prevent) JTAG operations if the JTAG pins are dedicated by an NVM configuration bit (via PSDsoft). However, the PSD reset input will prevent or interrupt JTAG operations if the JTAG enable register is used to enable the JTAG pins.

## The PSD835G2 Functional Blocks (cont.)

### 9.6.1 Standard JTAG Signals (cont.)

The PSD835G2 supports JTAG-ISP commands, but not Boundary Scan. ST's PSDsoft software tool and FlashLink JTAG programming cable implement these JTAG-ISC commands.

### 9.6.2 JTAG Extensions

TSTAT and  $\overline{\text{TERR}}$  are two JTAG extension signals enabled by a JTAG command received over the four standard JTAG pins (TMS, TCK, TDI, and TDO). They are used to speed programming and erase functions by indicating status on PSD pins instead of having to scan the status out serially using the standard JTAG channel. See Application Note 54.

$\overline{\text{TERR}}$  will indicate if an error has occurred when erasing a sector or programming in Flash memory. This signal will go low (active) when an error condition occurs, and stay low until a special JTAG command is executed or a chip reset pulse is received after an "ISC-DISABLE" command.

TSTAT behaves the same as the Rdy/Bsy signal described in section 9.1.1.2. TSTAT will be high when the PSD835G2 device is in read array mode (Flash memory and Boot Block contents can be read). TSTAT will be low when Flash memory programming or erase cycles are in progress, and also when data is being written to the Flash Boot Block.

TSTAT and  $\overline{\text{TERR}}$  can be configured as open-drain type signals with a JTAG command.

### 9.6.3 Security and Flash Memories Protection

When the security bit is set, the device cannot be read on a device programmer or through the JTAG Port. When using the JTAG Port, only a full chip erase command is allowed. All other program/erase/verify commands are blocked. Full chip erase returns the part to a non-secured blank state. The Security Bit can be set in PSDsoft.

All Flash Memory and Boot sectors can individually be sector protected against erasures. The sector protect bits can be set in PSDsoft.

### 10.0 Absolute Maximum Ratings

Symbol	Parameter	Condition	Min	Max	Unit
$T_{STG}$	Storage Temperature	PLDCC	- 65	+ 125	°C
	Operating Temperature	Commercial	0	+ 70	°C
		Industrial	- 40	+ 85	°C
	Voltage on any Pin	With Respect to GND	- 0.6	+ 7	V
$V_{PP}$	Device Programmer Supply Voltage	With Respect to GND	- 0.6	+ 14	V
$V_{CC}$	Supply Voltage	With Respect to GND	- 0.6	+ 7	V
	ESD Protection		>2000		V

**NOTE:** Stresses above those listed under Absolute Maximum Ratings may cause permanent damage to the device. This is a stress rating only and functional operation of the device at these or any other conditions above those indicated in the operational sections of this specification is not recommended. Exposure to Absolute Maximum Rating conditions for extended periods of time may affect device reliability.

### 11.0 Operating Range

Range	Temperature	$V_{CC}$ Tolerance
Commercial	0° C to +70°C	+ 5 V ± 10%
Industrial	-40° C to +85°C	+ 5 V ± 10%
Commercial	0° C to +70°C	3.0 V to 3.6 V
Industrial	-40° C to +85°C	3.0 V to 3.6 V

### 12.0 Recommended Operating Conditions

Symbol	Parameter	Condition	Min	Typ	Max	Unit
$V_{CC}$	Supply Voltage	All Speeds	4.5	5	5.5	V
$V_{CC}$	Supply Voltage	V-Versions All Speeds	3.0		3.6	V

### AC/DC Parameters

The following tables describe the AD/DC parameters of the PSD8XX family:

- DC Electrical Specification
- AC Timing Specification
  - PLD Timing
    - Combinatorial Timing
    - Synchronous Clock Mode
    - Asynchronous Clock Mode
    - Input Micro⇌Cell Timing
  - Microcontroller Timing
    - Read Timing
    - Write Timing
    - Peripheral Mode Timing
    - Power Down and Reset Timing

Following are issues concerning the parameters presented:

- In the DC specification the supply current is given for different modes of operation. Before calculating the total power consumption, determine the percentage of time that the PSD8XX is in each mode. Also, the supply power is considerably different if the Turbo bit is "OFF".
- The AC power component gives the PLD, Flash memory, and SRAM mA/MHz specification. Figures 32 and 32a show the PLD mA/MHz as a function of the number of Product Terms (PT) used.
- In the PLD timing parameters, add the required delay when Turbo bit is "OFF".

Figure 32. PLD  $I_{CC}$ /FrequencyConsumption ( $V_{CC} = 5\text{ V} \pm 10\%$ )

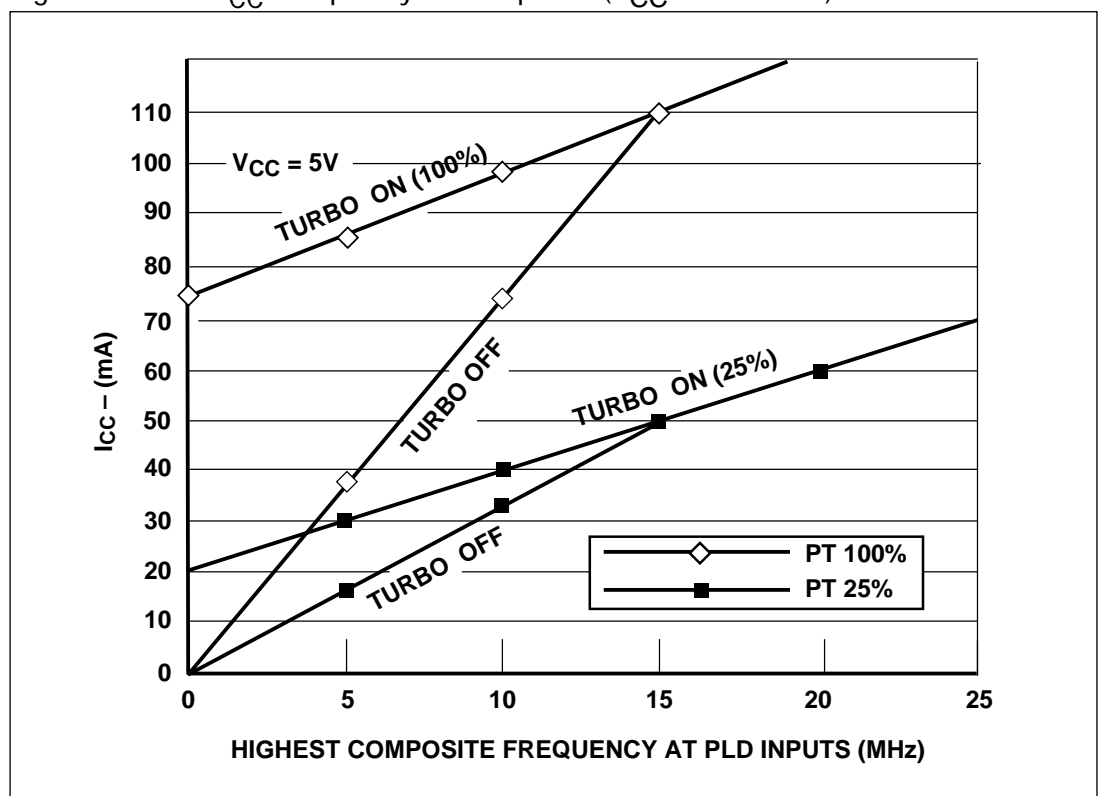

AC/DC  
Parameters  
(cont.)

Figure 30a. PLD  $I_{CC}$ /Frequency Consumption (PSD835G2V Versions,  $V_{CC} = 3\text{ V}$ )

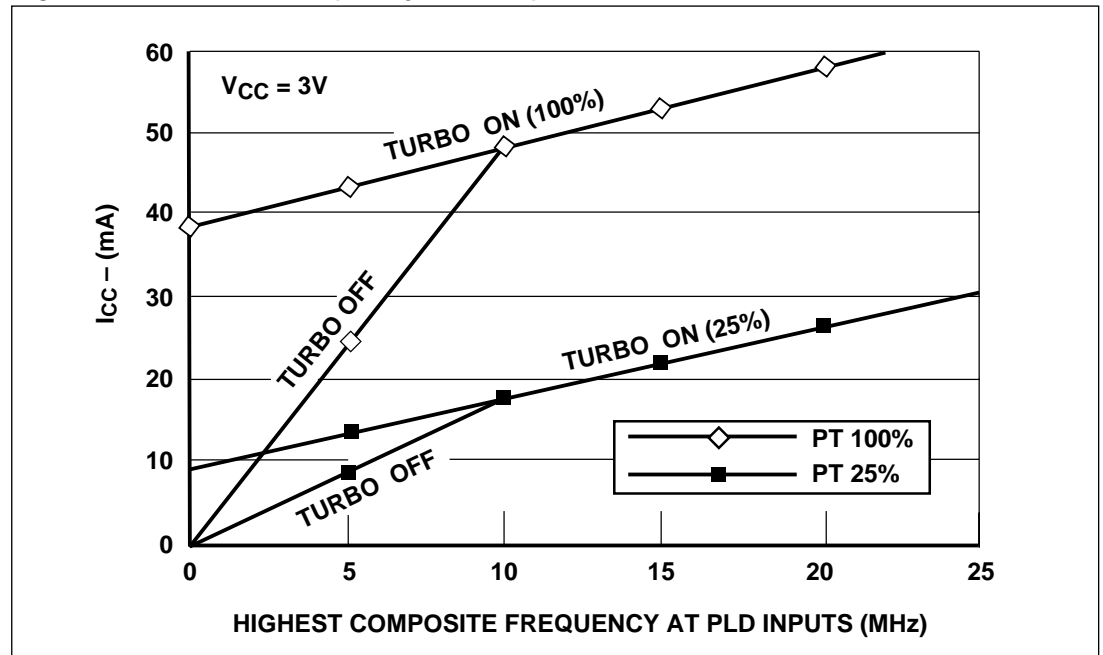

Example of PSD835G2 Typical Power Calculation at  $V_{CC} = 5.0\text{ V}$

Conditions	
Highest Composite PLD input frequency (Freq PLD)	= 8 MHz
MCU ALE frequency (Freq ALE)	= 4 MHz
% Flash Access	= 80%
% SRAM access	= 15%
% I/O access	= 5% (no additional power above base)
Operational Modes	
% Normal	= 10%
% Power Down Mode	= 90%
Number of product terms used (from fitter report)	
	= 45 PT
% of total product terms	= 45/193 = 23.3%
Turbo Mode	= ON
Calculation (typical numbers used)	
$I_{CC\ total} = I_{pwrdown} \times \%pwrdown + \%normal \times (I_{CC\ (ac)} + I_{CC\ (dc)})$ $= I_{pwrdown} \times \%pwrdown + \%normal \times (\%flash \times 2.5\text{ mA/MHz} \times \text{Freq ALE} + \%SRAM \times 1.5\text{ mA/MHz} \times \text{Freq ALE} + \%PLD \times 2\text{ mA/MHz} \times \text{Freq PLD} + \#PT \times 400\ \mu\text{A/PT})$ $= 50\ \mu\text{A} \times 0.90 + 0.1 \times (0.8 \times 2.5\text{ mA/MHz} \times 4\text{ MHz} + 0.15 \times 1.5\text{ mA/MHz} \times 4\text{ MHz} + 2\text{ mA/MHz} \times 8\text{ MHz} + 45 \times 0.4\text{ mA/PT})$ $= 45\ \mu\text{A} + 0.1 \times (8 + 0.9 + 16 + 18\text{ mA})$ $= 45\ \mu\text{A} + 0.1 \times 42.9$ $= 45\ \mu\text{A} + 4.29\text{ mA}$ $= \mathbf{4.34\text{ mA}}$	
This is the operating power with no Flash writes or erases. Calculation is based on $I_{OUT} = 0\text{ mA}$ .	

AC/DC  
Parameters  
(cont.)

Example of Typical Power Calculation at  $V_{CC} = 5.0\text{ V}$  in Turbo Off Mode

Conditions	
Highest Composite PLD input frequency (Freq PLD)	= 8 MHz
MCU ALE frequency (Freq ALE)	= 4 MHz
% Flash Access	= 80%
% SRAM access	= 15%
% I/O access	= 5% (no additional power above base)
Operational Modes	
% Normal	= 10%
% Power Down Mode	= 90%
Number of product terms used	
(from fitter report)	= 45 PT
% of total product terms	= 45/193 = 23.3%
Turbo Mode	= Off
Calculation (typical numbers used)	
$I_{CC\ total} = I_{pwrdown} \times \%pwrdown + \%normal \times (I_{CC\ (ac)} + I_{CC\ (dc)})$ $= I_{pwrdown} \times \%pwrdown + \%normal \times (\%flash \times 2.5\text{ mA/MHz} \times \text{Freq ALE} + \%SRAM \times 1.5\text{ mA/MHz} \times \text{Freq ALE} + \%PLD \times (\text{from graph using Freq PLD}))$ $= 50\ \mu\text{A} \times 0.90 + 0.1 \times (0.8 \times 2.5\text{ mA/MHz} \times 4\text{ MHz} + 0.15 \times 1.5\text{ mA/MHz} \times 4\text{ MHz} + 24\text{ mA})$ $= 45\ \mu\text{A} + 0.1 \times (8 + 0.9 + 24)$ $= 45\ \mu\text{A} + 0.1 \times 32.9$ $= 45\ \mu\text{A} + 3.29\text{ mA}$ $= \mathbf{3.34\text{ mA}}$	
<p>This is the operating power with no Flash writes or erases. Calculation is based on <math>I_{OUT} = 0\text{ mA}</math>.</p>	

PSD835G2 DC Characteristics (5 V  $\pm$  10% Versions)

Symbol	Parameter		Conditions	Min	Typ	Max	Unit
V <sub>CC</sub>	Supply Voltage		All Speeds	4.5	5	5.5	V
V <sub>IH</sub>	High Level Input Voltage		4.5 V < V <sub>CC</sub> < 5.5 V	2		V <sub>CC</sub> +.5	V
V <sub>IL</sub>	Low Level Input Voltage		4.5 V < V <sub>CC</sub> < 5.5 V	-.5		0.8	V
V <sub>IH1</sub>	Reset High Level Input Voltage		(Note 1)	.8 V <sub>CC</sub>		V <sub>CC</sub> +.5	V
V <sub>IL1</sub>	Reset Low Level Input Voltage		(Note 1)	-.5		.2 V <sub>CC</sub> -.1	V
V <sub>HYS</sub>	Reset Pin Hysteresis			0.3			V
V <sub>LKO</sub>	V <sub>CC</sub> Min for Flash Erase and Program			2.5		4.2	V
V <sub>OL</sub>	Output Low Voltage		I <sub>OL</sub> = 20 $\mu$ A, V <sub>CC</sub> = 4.5 V		0.01	0.1	V
			I <sub>OL</sub> = 8 mA, V <sub>CC</sub> = 4.5 V		0.25	0.45	V
V <sub>OH</sub>	Output High Voltage Except V <sub>STBY</sub> On		I <sub>OH</sub> = -20 $\mu$ A, V <sub>CC</sub> = 4.5 V	4.4	4.49		V
			I <sub>OH</sub> = -2 mA, V <sub>CC</sub> = 4.5 V	2.4	3.9		V
V <sub>OH1</sub>	Output High Voltage V <sub>STBY</sub> On		I <sub>OH1</sub> = -1 $\mu$ A	V <sub>SBY</sub> - 0.8			V
V <sub>SBY</sub>	SRAM Standby Voltage			2.0		V <sub>CC</sub>	V
I <sub>SBY</sub>	SRAM Standby Current (V <sub>STBY</sub> Pin)		V <sub>CC</sub> = 0 V		0.5	1	$\mu$ A
I <sub>IDLE</sub>	Idle Current (V <sub>STBY</sub> Pin)		V <sub>CC</sub> > V <sub>SBY</sub>	-0.1		0.1	$\mu$ A
V <sub>DF</sub>	SRAM Data Retention Voltage		Only on V <sub>STBY</sub>	2			V
I <sub>SB</sub>	Standby Supply Current for Power Down Mode		CSI > V <sub>CC</sub> -0.3 V (Notes 2, 3 and 5)		100	200	$\mu$ A
I <sub>LI</sub>	Input Leakage Current		V <sub>SS</sub> < V <sub>IN</sub> < V <sub>CC</sub>	-1	$\pm$ .1	1	$\mu$ A
I <sub>LO</sub>	Output Leakage Current		0.45 < V <sub>IN</sub> < V <sub>CC</sub>	-10	$\pm$ 5	10	$\mu$ A
I <sub>O</sub>	Output Current		Refer to I <sub>OL</sub> and I <sub>OH</sub> in the V <sub>OL</sub> and V <sub>OH</sub> row				
I <sub>CC</sub> (DC) (Note 5)	Operating Supply Current	PLD Only	PLD_TURBO = OFF, f = 0 MHz (Note 3)		0		mA
			PLD_TURBO = ON, f = 0 MHz		400	700	$\mu$ A/PT
		Flash	During Flash Write/Erase Only		15	30	mA
			Read Only, f = 0 MHz		0	0	mA
SRAM	f = 0 MHz		0	0	mA		
I <sub>CC</sub> (AC) (Note 5)	PLD AC Base			Fig. 32 (Note 4)			
	FLASH AC Adder				2.5	3.5	mA/MHz
	SRAM AC Adder				1.5	3.0	mA/MHz

- NOTE:** 1. Reset input has hysteresis. V<sub>IL1</sub> is valid at or below .2V<sub>CC</sub> -.1. V<sub>IH1</sub> is valid at or above .8V<sub>CC</sub>.  
2. CSI deselected or internal Power Down mode is active.  
3. PLD is in non-turbo mode and none of the inputs are switching  
4. Refer to Figure 32 for PLD current calculation.  
5. I<sub>O</sub> = 0 mA

## PSD835G2 AC/DC Parameters – GPLD Timing Parameters (5 V ± 10% Versions)

### GPLD Combinatorial Timing (5 V ± 10%)

Symbol	Parameter	Conditions	-70		-90		PT Aloc	TURBO OFF	Slew Rate (Note 1)	Unit
			Min	Max	Min	Max				
t <sub>PD</sub>	GPLD Input Pin/Feedback to GPLD Combinatorial Output			20		25	Add 2	Add 12	Sub 2	ns
t <sub>EA</sub>	GPLD Input to GPLD Output Enable			21		26		Add 12	Sub 2	ns
t <sub>ER</sub>	GPLD Input to GPLD Output Disable			21		26		Add 12	Sub 2	ns
t <sub>ARP</sub>	GPLD Register Clear or Preset Delay			21		26		Add 12	Sub 2	ns
t <sub>ARPW</sub>	GPLD Register Clear or Preset Pulse Width		10		20			Add 12		ns
t <sub>ARD</sub>	GPLD Array Delay	Any Micro↔Cell		11		16	Add 2			ns

**NOTE:** 1. Fast Slew Rate output available on Port C and F.

### GPLD Micro↔Cell Synchronous Clock Mode Timing (5 V ± 10% Versions)

Symbol	Parameter	Conditions	-70		-90		PT Aloc	TURBO OFF	Slew Rate (Note 1)	Unit
			Min	Max	Min	Max				
f <sub>MAX</sub>	Maximum Frequency External Feedback	1/(t <sub>S</sub> +t <sub>CO</sub> )		34.4		30.30				MHz
	Maximum Frequency Internal Feedback (f <sub>CNT</sub> )	1/(t <sub>S</sub> +t <sub>CO</sub> -10)		52.6		43.48				MHz
	Maximum Frequency Pipelined Data	1/(t <sub>CH</sub> +t <sub>CL</sub> )		83.3		50.00				MHz
t <sub>S</sub>	Input Setup Time		14		15		Add 2	Add 12		ns
t <sub>H</sub>	Input Hold Time		0		0					ns
t <sub>CH</sub>	Clock High Time	Clock Input	6		10					ns
t <sub>CL</sub>	Clock Low Time	Clock Input	6		10					ns
t <sub>CO</sub>	Clock to Output Delay	Clock Input		15		18			Sub 2	ns
t <sub>ARD</sub>	GPLD Array Delay	Any Micro↔Cell		11		16	Add 2			ns
t <sub>MIN</sub>	Minimum Clock Period	t <sub>CH</sub> +t <sub>CL</sub> (Note 2)	12		20					ns

**NOTES:** 1. Fast Slew Rate output available on Port C and F.

2. CLKIN t<sub>CLCL</sub> = t<sub>CH</sub> + t<sub>CL</sub>.

## PSD835G2 AC/DC Parameters – GPLD Timing Parameters (5 V ± 10% Versions)

### GPLD Micro↔Cell Asynchronous Clock Mode Timing (5 V ± 10% Versions)

Symbol	Parameter	Conditions	-70		-90		PT Aloc	TURBO OFF	Slew Rate	Unit
			Min	Max	Min	Max				
f <sub>MAXA</sub>	Maximum Frequency External Feedback	1/(t <sub>SA</sub> +t <sub>COA</sub> )		38.4		26.32				MHz
	Maximum Frequency Internal Feedback (f <sub>CNTA</sub> )	1/(t <sub>SA</sub> +t <sub>COA</sub> -10)		62.5		35.71				MHz
	Maximum Frequency Pipelined Data	1/(t <sub>CHA</sub> +t <sub>CLA</sub> )		47.6		37.03				MHz
t <sub>SA</sub>	Input Setup Time		6		8		Add 2	Add 12		ns
t <sub>HA</sub>	Input Hold Time		7		12					ns
t <sub>CHA</sub>	Clock Input High Time		9		12			Add 12		ns
t <sub>CLA</sub>	Clock Input Low Time		12		15			Add 12		ns
t <sub>COA</sub>	Clock to Output Delay			21		30		Add 12	Sub 2	ns
t <sub>ARDA</sub>	GPLD Array Delay	Any Micro↔Cell		11		16	Add 2			ns
t <sub>MINA</sub>	Minimum Clock Period	1/f <sub>CNTA</sub>	16		28					ns

### Input Micro↔Cell Timing (5 V ± 10% Versions)

Symbol	Parameter	Conditions	-70		-90		PT Aloc	TURBO OFF	Unit
			Min	Max	Min	Max			
t <sub>IS</sub>	Input Setup Time	(Note 1)	0		0				ns
t <sub>IH</sub>	Input Hold Time	(Note 1)	15		20			Add 12	ns
t <sub>INH</sub>	NIB Input High Time	(Note 1)	9		12				ns
t <sub>INL</sub>	NIB Input Low Time	(Note 1)	9		12				ns
t <sub>INO</sub>	NIB Input to Combinatorial Delay	(Note 1)		34		46	Add 2	Add 12	ns

**NOTE:** 1. Inputs from Port A, B, and C relative to register/latch clock from the PLD. ALE latch timings refer to t<sub>AVLX</sub> and t<sub>LXAX</sub>.

Microcontroller  
Interface –  
AC/DC  
Parameters  
(5V ± 10% Versions)

AC Symbols for PLD Timing.

Example:  $t_{AVLX}$  – Time from Address Valid to ALE Invalid.

Signal Letters

- A** – Address Input
- C** – CEout Output
- D** – Input Data
- E** – E Input
- I** – Interrupt Input
- L** – ALE Input
- N** – Reset Input or Output
- P** – Port Signal Output
- R** –  $\overline{UDS}$ ,  $\overline{LDS}$ ,  $\overline{DS}$ ,  $\overline{RD}$ ,  $\overline{PSEN}$  Inputs
- S** – Chip Select Input
- T** –  $\overline{R/W}$  Input
- W** – WR Input
- B** – Vstby Output
- M** – Output Micro $\leftrightarrow$ Cell

Signal Behavior

- t** – Time
- L** – Logic Level Low or ALE
- H** – Logic Level High
- V** – Valid
- X** – No Longer a Valid Logic Level
- Z** – Float
- PW** – Pulse Width

## Microcontroller Interface – PSD835G2 AC/DC Parameters

(5V ± 10% Versions)

## Read Timing (5 V ± 10% Versions)

Symbol	Parameter	Conditions	-70		-90		Turbo Off	Unit
			Min	Max	Min	Max		
t <sub>LVLX</sub>	ALE or AS Pulse Width		15		20			ns
t <sub>AVLX</sub>	Address Setup Time	(Note 3)	4		6			ns
t <sub>LXAX</sub>	Address Hold Time	(Note 3)	7		8			ns
t <sub>AVQV</sub>	Address Valid to Data Valid	(Note 3)		70		90	Add 12	ns
t <sub>SLQV</sub>	CS Valid to Data Valid			75		100		ns
t <sub>RLQV</sub>	$\overline{RD}$ to Data Valid	(Note 5)		24		32		ns
	$\overline{RD}$ or $\overline{PSEN}$ to Data Valid, 80C51 Mode	(Note 2)		31		38		ns
t <sub>RHQX</sub>	$\overline{RD}$ Data Hold Time	(Note 1)	0		0			ns
t <sub>RLRH</sub>	$\overline{RD}$ Pulse Width	(Note 1)	27		32			ns
t <sub>RHQZ</sub>	$\overline{RD}$ to Data High-Z	(Note 1)		20		25		ns
t <sub>EHEL</sub>	E Pulse Width		27		32			ns
t <sub>THEH</sub>	$\overline{R/W}$ Setup Time to Enable		6		10			ns
t <sub>ELTL</sub>	$\overline{R/W}$ Hold Time After Enable		0		0			ns
t <sub>AVPV</sub>	Address Input Valid to Address Output Delay	(Note 4)		20		25		ns

- NOTES:**
1.  $\overline{RD}$  timing has the same timing as  $\overline{DS}$  and  $\overline{PSEN}$  signals.
  2.  $\overline{RD}$  and  $\overline{PSEN}$  have the same timing.
  3. Any input used to select an internal PSD835G2 function.
  4. In multiplexed mode, latched addresses generated from ADIO delay to address output on any Port.
  5.  $\overline{RD}$  timing has the same timing as  $\overline{DS}$ .

## Microcontroller Interface – PSD835G2 AC/DC Parameters

(5V ± 10% Versions)

## Write Timing (5 V ± 10% Versions)

Symbol	Parameter	Conditions	-70		-90		Unit
			Min	Max	Min	Max	
t <sub>LVLX</sub>	ALE or AS Pulse Width		15		20		
t <sub>AVLX</sub>	Address Setup Time	(Note 1)	4		6		ns
t <sub>LXAX</sub>	Address Hold Time	(Note 1)	7		8		ns
t <sub>AVWL</sub>	Address Valid to Leading Edge of $\overline{WR}$	(Notes 1 and 3)	8		15		ns
t <sub>SLWL</sub>	$\overline{CS}$ Valid to Leading Edge of $\overline{WR}$	(Note 3)	12		15		ns
t <sub>DVWH</sub>	$\overline{WR}$ Data Setup Time	(Note 3)	25		35		ns
t <sub>WHDX</sub>	$\overline{WR}$ Data Hold Time	(Notes 3 and 7)	4		5		ns
t <sub>WLWH</sub>	$\overline{WR}$ Pulse Width	(Note 3)	28		35		ns
t <sub>WHAX1</sub>	Trailing Edge of $\overline{WR}$ to Address Invalid	(Note 3)	6		8		ns
t <sub>WHAX2</sub>	Trailing Edge of $\overline{WR}$ to DPLD Address Input Invalid	(Note 3 and 6)	0		0		ns
t <sub>WHPV</sub>	Trailing Edge of $\overline{WR}$ to Port Output Valid Using I/O Port Data Register	(Note 3)		27		30	ns
t <sub>WLMV</sub>	$\overline{WR}$ Valid to Port Output Valid Using Micro $\leftrightarrow$ Cell Register Preset/Clear	(Notes 3 and 4)		48		55	ns
t <sub>DVMV</sub>	Data Valid to Port Output Valid Using Micro $\leftrightarrow$ Cell Register Preset/Clear	(Notes 3 and 5)		42		55	ns
t <sub>AVPV</sub>	Address Input Valid to Address Output Delay	(Note 2)		20		25	ns

- NOTES:**
- Any input used to select an internal PSD8XX function.
  - In multiplexed mode, latched addresses generated from ADIO delay to address output on any Port.
  - $\overline{WR}$  timing has the same timing as E and  $\overline{DS}$  signals.
  - Assuming data is stable before active write signal.
  - Assuming write is active before data becomes valid.
  - t<sub>WHAX2</sub> is Address Hold Time for DPLD inputs that are used to generate chip selects for internal PSD memory.
  - t<sub>WHDX</sub> is 6ns when writing to the Output Micro $\leftrightarrow$ Cell Registers AB and BC.

## Microcontroller Interface – PSD835G2 AC/DC Parameters

(5V ± 10% Versions)

## Port F Peripheral Data Mode Read Timing (5 V ± 10%)

Symbol	Parameter	Conditions	-70		-90		Turbo Off	Unit
			Min	Max	Min	Max		
t <sub>AVQV</sub> (PF)	Address Valid to Data Valid	(Note 3)		30		35	Add 12	ns
t <sub>SLQV</sub> (PF)	$\overline{\text{CSI}}$ Valid to Data Valid			25		35	Add 12	ns
t <sub>RLQV</sub> (PF)	$\overline{\text{RD}}$ to Data Valid	(Notes 1 and 4)		21		32		ns
	$\overline{\text{RD}}$ to Data Valid 8031 Mode			31		38		ns
t <sub>DVQV</sub> (PF)	Data In to Data Out Valid			22		30		ns
t <sub>QXRH</sub> (PF)	$\overline{\text{RD}}$ Data Hold Time		0		0			ns
t <sub>RLRH</sub> (PF)	$\overline{\text{RD}}$ Pulse Width	(Note 1)	27		32			ns
t <sub>RHQZ</sub> (PF)	$\overline{\text{RD}}$ to Data High-Z	(Note 1)		23		25		ns

## Port F Peripheral Data Mode Write Timing (5 V ± 10%)

Symbol	Parameter	Conditions	-70		-90		Unit
			Min	Max	Min	Max	
t <sub>WLQV</sub> (PF)	$\overline{\text{WR}}$ to Data Propagation Delay	(Note 2)		25		35	ns
t <sub>DVQV</sub> (PF)	Data to Port F Data Propagation Delay	(Note 5)		22		30	ns
t <sub>WHQZ</sub> (PF)	$\overline{\text{WR}}$ Invalid to Port F Tri-state	(Note 2)		20		25	ns

- NOTES:**
1.  $\overline{\text{RD}}$  timing has the same timing as  $\overline{\text{DS}}$  and  $\overline{\text{PSEN}}$  signals.
  2.  $\overline{\text{WR}}$  timing has the same timing as E and  $\overline{\text{DS}}$  signals.
  3. Any input used to select Port F Data Peripheral Mode.
  4. Data is already stable on Port F.
  5. Data stable on ADIO pins to data on Port F.

## Microcontroller Interface – PSD835G2 AC/DC Parameters

(5V ± 10% Versions)

## Power Down Timing (5 V ± 10%)

Symbol	Parameter	Conditions	-70		-90		Unit
			Min	Max	Min	Max	
$t_{LVDV}$	ALE Access Time from Power Down			80		90	ns
$t_{CLWH}$	Maximum Delay from APD Enable to Internal PDN Valid Signal	Using CLKIN Input	15 * $t_{CLCL}$ ( $\mu$ s) (Note 1)				$\mu$ s

**NOTE:** 1.  $t_{CLCL}$  is the CLKIN clock period. $V_{stbyon}$  Timing (5 V ± 10%)

Symbol	Parameter	Conditions	Min	Typ	Max	Unit
$t_{BVBH}$	$V_{stby}$ Detection to $V_{stbyon}$ Output High	(Note 1)		20		$\mu$ s
$t_{BXBL}$	$V_{stby}$ Off Detection to $V_{stbyon}$ Output Low	(Note 1)		20		$\mu$ s

**NOTE:** 1.  $V_{stbyon}$  is measured at  $V_{CC}$  ramp rate of 2 ms.

## Reset Pin Timing (5 V ± 10%)

Symbol	Parameter	Conditions	Min	Typ	Max	Unit
$t_{NLNH}$	Warm RESET Active Low Time (Note 1)		150			ns
$t_{OPR}$	RESET High to Operational Device				120	ns
$t_{NLNH-PO}$	Power On Reset Active Low Time		1			ms
$t_{NLNH-A}$	Warm RESET Active Low Time (Note 2)		25			$\mu$ s

**NOTE:** 1. RESET will not abort Flash programming/erase cycles.  
2. RESET will abort Flash programming or erase cycle.

## Microcontroller Interface – PSD835G2 AC/DC Parameters

(5V ± 10% Versions)

## Flash Program, Write and Erase Times (5 V ± 10%)

Symbol	Parameter	Min	Typ	Max	Unit
	Flash Program		8.5		sec
	Flash Bulk Erase (Preprogrammed to 00) (Note 1)		3	30	sec
	Flash Bulk Erase		10		sec
t <sub>WHQV3</sub>	Sector Erase (Preprogrammed to 00)		1	30	sec
t <sub>WHQV2</sub>	Sector Erase		2.2		sec
t <sub>WHQV1</sub>	Word Program		14	1200	µs
	Program/Erase Cycles (Per Sector)	100,000			cycles
t <sub>WHWLO</sub>	Sector Erase Time-Out		100		µs
t <sub>Q7VQV</sub>	DQ7 Valid to Output Valid (Data Polling) (Note 2)			30	ns

**NOTE:** 1. Programmed to all zeros before erase.  
2. The polling status DQ7 is valid t<sub>Q7VQV</sub> ns before the data DQ0-7 is valid for reading.

## ISC Timing (5 V ± 10%)

Symbol	Parameter	Conditions	-70		-90		Unit
			Min	Max	Min	Max	
t <sub>ISCCF</sub>	TCK Clock Frequency (except for PLD)	(Note 1)		20		18	MHz
t <sub>ISCCH</sub>	TCK Clock High Time	(Note 1)	23		26		ns
t <sub>ISCCL</sub>	TCK Clock Low Time	(Note 1)	23		26		ns
t <sub>ISCCF-P</sub>	TCK Clock Frequency (for PLD only)	(Note 2)		2		2	MHz
t <sub>ISCCH-P</sub>	TCK Clock High Time(for PLD only)	(Note 2)	240		240		ns
t <sub>ISCCL-P</sub>	TCK Clock Low Time(for PLD only)	(Note 2)	240		240		ns
t <sub>ISCPsu</sub>	ISC Port Set Up Time		6		8		ns
t <sub>ISCPH</sub>	ISC Port Hold Up Time		5		5		ns
t <sub>ISPCO</sub>	ISC Port Clock to Output			21		23	ns
t <sub>ISCPZV</sub>	ISC Port High-Impedance to Valid Output			21		23	ns
t <sub>ISCPVZ</sub>	ISC Port Valid Output to High-Impedance			21		23	ns

**NOTES:** 1. For “non-PLD” programming, erase or in ISC by-pass mode.  
2. For program or erase PLD only.

## PSD835G2 DC Characteristics (3.0 V to 3.6 V Versions) Advance Information

Symbol	Parameter	Conditions	Min	Typ	Max	Unit	
V <sub>CC</sub>	Supply Voltage	All Speeds	3.0		3.6	V	
V <sub>IH</sub>	High Level Input Voltage	3.0 V < V <sub>CC</sub> < 3.6 V	.7 V <sub>CC</sub>		V <sub>CC</sub> +.5	V	
V <sub>IL</sub>	Low Level Input Voltage	3.0 V < V <sub>CC</sub> < 3.6 V	-.5		0.8	V	
V <sub>IH1</sub>	Reset High Level Input Voltage	(Note 1)	.8 V <sub>CC</sub>		V <sub>CC</sub> +.5	V	
V <sub>IL1</sub>	Reset Low Level Input Voltage	(Note 1)	-.5		.2 V <sub>CC</sub> -.1	V	
V <sub>HYS</sub>	Reset Pin Hysteresis		0.3			V	
V <sub>LKO</sub>	V <sub>CC</sub> Min for Flash Erase and Program		1.5		2.3	V	
V <sub>OL</sub>	Output Low Voltage	I <sub>OL</sub> = 20 μA, V <sub>CC</sub> = 3.0 V		0.01	0.1	V	
		I <sub>OL</sub> = 4 mA, V <sub>CC</sub> = 3.0 V		0.15	0.45	V	
V <sub>OH</sub>	Output High Voltage Except V <sub>STBY</sub> On	I <sub>OH</sub> = -20 μA, V <sub>CC</sub> = 3.0 V	2.9	2.99		V	
		I <sub>OH</sub> = -1 mA, V <sub>CC</sub> = 3.0 V	2.7	2.8		V	
V <sub>OH1</sub>	Output High Voltage V <sub>STBY</sub> On	I <sub>OH1</sub> = 1 μA	V <sub>SBY</sub> - 0.8			V	
V <sub>SBY</sub>	SRAM Standby Voltage		2.0		V <sub>CC</sub>	V	
I <sub>SBY</sub>	SRAM Standby Current (V <sub>STBY</sub> Pin)	V <sub>CC</sub> = 0 V		0.5	1	μA	
I <sub>IDLE</sub>	Idle Current (V <sub>STBY</sub> Pin)	V <sub>CC</sub> > V <sub>SBY</sub>	-0.1		0.1	μA	
V <sub>DF</sub>	SRAM Data Retention Voltage	Only on V <sub>STBY</sub>	2			V	
I <sub>SB</sub>	Standby Supply Current for Power Down Mode	CSI > V <sub>CC</sub> - 0.3 V (Notes 2 and 3)		50	100	μA	
I <sub>LI</sub>	Input Leakage Current	V <sub>SS</sub> < V <sub>IN</sub> < V <sub>CC</sub>	-1	±.1	1	μA	
I <sub>LO</sub>	Output Leakage Current	0.45 < V <sub>IN</sub> < V <sub>CC</sub>	-10	±5	10	μA	
I <sub>O</sub>	Output Current	Refer to I <sub>OL</sub> and I <sub>OH</sub> in the V <sub>OL</sub> and V <sub>OH</sub> row					
I <sub>CC</sub> (DC) (Note 5)	Operating Supply Current	PLD Only	ZPLD_TURBO = OFF, f = 0 MHz (Note 3)		0		mA
			ZPLD_TURBO = ON, f = 0 MHz		200	400	μA/PT
		FLASH	During FLASH Write/Erase Only		10	25	mA
			Read Only, f = 0 MHz		0	0	mA
SRAM	f = 0 MHz		0	0	mA		
I <sub>CC</sub> (AC) (Note 5)	PLD AC Base			(Note 4)		Figure 32a	
	FLASH AC Adder			1.5	2.0	mA/MHz	
	SRAM AC Adder			0.8	1.5	mA/MHz	

- NOTES:**
- Reset input has hysteresis. V<sub>IL1</sub> is valid at or below .2V<sub>CC</sub> -.1. V<sub>IH1</sub> is valid at or above .8V<sub>CC</sub>.
  - CSI deselected or internal PD mode is active.
  - PLD is in non-turbo mode and none of the inputs are switching.
  - Refer to Figure 31a for PLD current calculation.
  - I<sub>O</sub> = 0 mA.

## PSD835G2 AC/DC Parameters – CPLD Timing Parameters

(3.0 V to 3.6 V Versions)

## GPLD Combinatorial Timing (3.0 V to 3.6 V Versions)

Symbol	Parameter	Conditions	-90		-12		PT Alloc	TURBO OFF	Slew Rate (Note 1)	Unit
			Min	Max	Min	Max				
$t_{PD}$	GPLD Input Pin/Feedback to GPLD Combinatorial Output			38		43	Add 4	Add 20	Sub 6	ns
$t_{EA}$	GPLD Input to GPLD Output Enable			43		45		Add 20	Sub 6	ns
$t_{ER}$	GPLD Input to GPLD Output Disable			43		45		Add 20	Sub 6	ns
$t_{ARP}$	GPLD Register Clear or Preset Delay			38		43		Add 20	Sub 6	ns
$t_{ARPW}$	GPLD Register Clear or Preset Pulse Width		28		30			Add 20		ns
$t_{ARD}$	GPLD Array Delay	Any Micro $\leftrightarrow$ Cell		23		27	Add 4			ns

**NOTE:** 1. Fast Slew Rate output available on Port C and F.GPLD Micro $\leftrightarrow$ Cell Synchronous Clock Mode Timing (3.0 V to 3.6 V Versions)

Symbol	Parameter	Conditions	-90		-12		PT Alloc	TURBO OFF	Slew Rate (Note 1)	Unit
			Min	Max	Min	Max				
$f_{MAX}$	Maximum Frequency External Feedback	$1/(t_S+t_{CO})$		24.3		20.4				MHz
	Maximum Frequency Internal Feedback ( $f_{CNT}$ )	$1/(t_S+t_{CO}-10)$		32.2		25.6				MHz
	Maximum Frequency Pipelined Data	$1/(t_{CH}+t_{CL})$		45.0		35.7				MHz
$t_S$	Input Setup Time		18		23	Add 4	Add 20			ns
$t_H$	Input Hold Time		0		0					ns
$t_{CH}$	Clock High Time	Clock Input	11		14					ns
$t_{CL}$	Clock Low Time	Clock Input	11		14					ns
$t_{CO}$	Clock to Output Delay	Clock Input		23		26			Sub 6	ns
$t_{ARD}$	GPLD Array Delay	Any Micro $\leftrightarrow$ Cell		23		27	Add 4			ns
$t_{MIN}$	Minimum Clock Period	$t_{CH}+t_{CL}$ (Note 2)	22		28					ns

**NOTES:** 1. Fast Slew Rate output available on Port C and F.2. CLKIN  $t_{CLCL} = t_{CH} + t_{CL}$ .

## PSD835G2 AC/DC Parameters – GPLD Timing Parameters

(3.0 V to 3.6 V Versions)

## GPLD Micro↔Cell Asynchronous Clock Mode Timing (3.0 V to 3.6 V Versions)

Symbol	Parameter	Conditions	-90		-12		PT Aloc	TURBO OFF	Slew Rate	Unit
			Min	Max	Min	Max				
f <sub>MAXA</sub>	Maximum Frequency External Feedback	1/(t <sub>SA</sub> +t <sub>COA</sub> )		23.8		20.8				MHz
	Maximum Frequency Internal Feedback (f <sub>CNTA</sub> )	1/(t <sub>SA</sub> +t <sub>COA</sub> -10)		31.25		26.3				MHz
	Maximum Frequency Pipelined Data	1/(t <sub>CHA</sub> +t <sub>CLA</sub> )		38.4		30.3				MHz
t <sub>SA</sub>	Input Setup Time		8		10		Add 4	Add 20		ns
t <sub>HA</sub>	Input Hold Time		10		12					ns
t <sub>CHA</sub>	Clock High Time		15		18			Add 20		ns
t <sub>CLA</sub>	Clock Low Time		12		15			Add 20		ns
t <sub>COA</sub>	Clock to Output Delay			34		38		Add 20	Sub 6	ns
t <sub>ARD</sub>	GPLD Array Delay	Any Micro↔Cell		23		27	Add 4			ns
t <sub>MINA</sub>	Minimum Clock Period	1/f <sub>CNTA</sub>	32		38					ns

## Input Micro↔Cell Timing (3.0 V to 3.6 V Versions)

Symbol	Parameter	Conditions	-90		-12		PT Aloc	TURBO OFF	Unit
			Min	Max	Min	Max			
t <sub>IS</sub>	Input Setup Time	(Note 1)	0		0				ns
t <sub>IH</sub>	Input Hold Time	(Note 1)	20		23			Add 20	ns
t <sub>INH</sub>	NIB Input High Time	(Note 1)	13		13				ns
t <sub>INL</sub>	NIB Input Low Time	(Note 1)	12		13				ns
t <sub>INO</sub>	NIB Input to Combinatorial Delay	(Note 1)		46		62	Add 4	Add 20	ns

**NOTE:** 1. Inputs from Port A, B, and C relative to register/latch clock from the PLD. ALE latch timings refer to t<sub>AVLX</sub> and t<sub>LXAX</sub>.

Microcontroller  
Interface –  
PSD835G2  
AC/DC  
Parameters  
(3.0 V to 3.6 V  
Versions)

### AC Symbols for PLD Timing.

Example:  $t_{AVLX}$  – Time from Address Valid to ALE Invalid.

### Signal Letters

- A** – Address Input
- C** – CEout Output
- D** – Input Data
- E** – E Input
- G** – Internal WDOG\_ON signal
- I** – Interrupt Input
- L** – ALE Input
- N** – Reset Input or Output
- P** – Port Signal Output
- Q** – Output Data
- R** –  $\overline{WR}$ ,  $\overline{UDS}$ ,  $\overline{LDS}$ ,  $\overline{DS}$ ,  $\overline{IORD}$ ,  $\overline{PSEN}$  Inputs
- S** – Chip Select Input
- T** –  $\overline{R/W}$  Input
- W** – Internal PDN Signal
- B** – Vstby Output
- M** – Output Micro $\Leftrightarrow$ Cell

### Signal Behavior

- t** – Time
- L** – Logic Level Low or ALE
- H** – Logic Level High
- V** – Valid
- X** – No Longer a Valid Logic Level
- Z** – Float
- PW** – Pulse Width

## Microcontroller Interface – PSD835G2 AC/DC Parameters

(3.0 V to 3.6 V Versions)

## Read Timing (3.0 V to 3.6 V Versions)

Symbol	Parameter	Conditions	-90		-12		Turbo Off	Unit
			Min	Max	Min	Max		
t <sub>LVLX</sub>	ALE or AS Pulse Width		22		24			ns
t <sub>AVLX</sub>	Address Setup Time	(Note 3)	7		9			ns
t <sub>LXAX</sub>	Address Hold Time	(Note 3)	8		10			ns
t <sub>AVQV</sub>	Address Valid to Data Valid	(Note 3)		90		120	Add 20**	ns
t <sub>SLQV</sub>	CS Valid to Data Valid			90		120		ns
t <sub>RLQV</sub>	$\overline{RD}$ to Data Valid	(Note 5)		35		35		ns
	$\overline{RD}$ or $\overline{PSEN}$ to Data Valid, 80C51XA Mode	(Note 2)		45		48		ns
t <sub>RHQX</sub>	$\overline{RD}$ Data Hold Time	(Note 1)	0		0			ns
t <sub>RLRH</sub>	$\overline{RD}$ Pulse Width	(Note 1)	36		40			ns
t <sub>RHQZ</sub>	$\overline{RD}$ to Data High-Z	(Note 1)		38		40		ns
t <sub>EHEL</sub>	E Pulse Width		38		42			ns
t <sub>THEH</sub>	$\overline{R/\overline{W}}$ Setup Time to Enable		10		16			ns
t <sub>ELTL</sub>	$\overline{R/\overline{W}}$ Hold Time After Enable		0		0			ns
t <sub>AVPV</sub>	Address Input Valid to Address Output Delay	(Note 4)		30		35		ns

- NOTES:**
1.  $\overline{RD}$  timing has the same timing as  $\overline{DS}$  and  $\overline{PSEN}$  signals.
  2.  $\overline{RD}$  and  $\overline{PSEN}$  have the same timing for 80C51.
  3. Any input used to select an internal PSD835G2V function.
  4. In multiplexed mode latched address generated from ADIO delay to address output on any Port.
  5.  $\overline{RD}$  timing has the same timing as  $\overline{DS}$ .

## Microcontroller Interface – PSD835G2 AC/DC Parameters

(3.0 V to 3.6 V Versions)

## Write Timing (3.0 V to 3.6 V Versions)

Symbol	Parameter	Conditions	-90		-12		Unit
			Min	Max	Min	Max	
$t_{LVLX}$	ALE or AS Pulse Width		22		24		
$t_{AVLX}$	Address Setup Time	(Note 1)	7		9		ns
$t_{LXAX}$	Address Hold Time	(Note 1)	8		10		ns
$t_{AVWL}$	Address Valid to Leading Edge of $\overline{WR}$	(Notes 1 and 3)	15		18		ns
$t_{SLWL}$	$\overline{CS}$ Valid to Leading Edge of $\overline{WR}$	(Note 3)	15		18		ns
$t_{DVWH}$	$\overline{WR}$ Data Setup Time	(Note 3)	40		45		ns
$t_{WHDX}$	$\overline{WR}$ Data Hold Time	(Notes 3 and 7)	5		8		ns
$t_{WLWH}$	$\overline{WR}$ Pulse Width	(Note 3)	40		45		ns
$t_{WHAX1}$	Trailing Edge of $\overline{WR}$ to Address Invalid	(Note 3)	8		10		ns
$t_{WHAX2}$	Trailing Edge of $\overline{WR}$ to DPLD Address Input Invalid	(Notes 3 and 6)	0		0		ns
$t_{WHPV}$	Trailing Edge of $\overline{WR}$ to Port Output Valid Using I/O Port Data Register	(Note 3)		33		33	ns
$t_{WLMV}$	$\overline{WR}$ Valid to Port Output Valid Using Micro $\leftrightarrow$ Cell Register Preset/Clear	(Notes 3 and 4)		65		70	ns
$t_{DVMV}$	Data Valid to Port Output Valid Using Micro $\leftrightarrow$ Cell Register Preset/Clear	(Notes 3 and 5)		65		68	ns
$t_{AVPV}$	Address Input Valid to Address Output Delay	(Note 2)		30		35	ns

- NOTES:**
1. Any input used to select an internal PSD835G2 function.
  2. In multiplexed mode, latched addresses generated from ADIO delay to address output on any Port.
  3.  $\overline{WR}$  timing has the same timing as E and DS signals.
  4. Assuming data is stable before active write signal.
  5. Assuming write is active before data becomes valid.
  6.  $t_{WHAX2}$  is Address hold time for DPLD inputs that are used to generate chip selects for internal PSD memory.
  7.  $t_{WHDX}$  is 11ns when writing to the Output Micro $\leftrightarrow$ Cell Registers AB and BC.

## Microcontroller Interface – PSD835G2 AC/DC Parameters

(3.0 V to 3.6 V Versions)

## Port F Peripheral Data Mode Read Timing (3.0 V to 3.6 V Versions)

Symbol	Parameter	Conditions	-90		-12		Turbo Off	Unit
			Min	Max	Min	Max		
$t_{AVQV} (PF)$	Address Valid to Data Valid	(Note 3)		50		50	Add 20	ns
$t_{SLQV} (PF)$	$\overline{CS}$ Valid to Data Valid			35		40	Add 20	ns
$t_{RLQV} (PF)$	$\overline{RD}$ to Data Valid	(Notes 1 and 4)		35		40		ns
	$\overline{RD}$ to Data Valid, 8031 Mode			45		45		ns
$t_{DVQV} (PF)$	Data In to Data Out Valid			34		38		ns
$t_{QXRH} (PF)$	$\overline{RD}$ Data Hold Time		0		0			ns
$t_{RLRH} (PF)$	$\overline{RD}$ Pulse Width	(Note 1)	35		36			ns
$t_{RHQZ} (PF)$	$\overline{RD}$ to Data High-Z	(Note 1)		38		40		ns

## Port F Peripheral Data Mode Write Timing (3.0 V to 3.6 V Versions)

Symbol	Parameter	Conditions	-90		-12		Unit
			Min	Max	Min	Max	
$t_{WLQV} (PF)$	$\overline{WR}$ to Data Propagation Delay	(Note 2)		40		43	ns
$t_{DVQV} (PF)$	Data to Port F Data Propagation Delay	(Note 5)		35		38	ns
$t_{WHQZ} (PF)$	$\overline{WR}$ Invalid to Port F Tri-state	(Note 2)		33		33	ns

- NOTES:**
- $\overline{RD}$  timing has the same timing as  $\overline{DS}$  and  $\overline{PSEN}$  signals.
  - $\overline{WR}$  timing has the same timing as E and  $\overline{DS}$  signals.
  - Any input used to select Port F Data Peripheral Mode.
  - Data is already stable on Port F.
  - Data stable on ADIO pins to data on Port F.

## Microcontroller Interface – PSD835G2 AC/DC Parameters

(3.0 V to 3.6 V Versions)

## Power Down Timing (3.0 V to 3.6 V Versions)

Symbol	Parameter	Conditions	-90		-12		Unit
			Min	Max	Min	Max	
$t_{LVDV}$	ALE Access Time from Power Down			128		135	ns
$t_{CLWH}$	Maximum Delay from APD Enable to Internal PDN Valid Signal	Using CLKIN Input	15 * $t_{CLCL}$ ( $\mu$ s) (Note 1)				$\mu$ s

**NOTE:** 1.  $t_{CLCL}$  is the CLKIN clock period. $V_{stbyon}$  Timing (3.0 V to 3.6 V Versions)

Symbol	Parameter	Conditions	Min	Typ	Max	Unit
$t_{BVBH}$	$V_{stby}$ Detection to $V_{stbyon}$ Output High	(Note 1)		20		$\mu$ s
$t_{BXBL}$	$V_{stby}$ Off Detection to $V_{stbyon}$ Output Low	(Note 1)		20		$\mu$ s

**NOTE:** 1.  $V_{stbyon}$  is measured at  $V_{CC}$  ramp rate of 2 ms.

## Reset Pin Timing (3.0 V to 3.6 V Versions)

Symbol	Parameter	Conditions	Min	Typ	Max	Unit
$t_{NLNH}$	Warm RESET Active Low Time (Note 1)		300			ns
$t_{OPR}$	RESET High to Operational Device				300	ns
$t_{NLNH-PO}$	Power On Reset Active Low Time		1			ms
$t_{NLNH-A}$	Warm RESET Active Low Time (Note 2)		25			$\mu$ s

**NOTE:** 1. RESET will not abort Flash programming/erase cycles.

2. RESET will abort Flash programming or erase cycle.

## Microcontroller Interface – PSD835G2 AC/DC Parameters

(3.0 V to 3.6 V Versions)

## Flash Program, Write and Erase Times (3.0 V to 3.6 V Versions)

Symbol	Parameter	Min	Typ	Max	Unit
	Flash Program		8.5		sec
	Flash Bulk Erase (Preprogrammed to 00) (Note 1)		3	30	sec
	Flash Bulk Erase		10		sec
t <sub>WHQV3</sub>	Sector Erase (Preprogrammed to 00)		1	30	sec
t <sub>WHQV2</sub>	Sector Erase		2.2		sec
t <sub>WHQV1</sub>	Word Program		14	1200	µs
	Program/Erase Cycles (Per Sector)	100,000			cycles
t <sub>WHWLO</sub>	Sector Erase Time-Out		100		µs
t <sub>Q7VQV</sub>	DQ7 Valid to Output Valid (Data Polling) (Note 2)			30	ns

**NOTES:** 1. Programmed to all zeros before erase.2. The polling status DQ7 is valid t<sub>Q7VQV</sub> ns before the data DQ0-7 is valid for reading.

## ISC Timing (3.0 V to 3.6 V Versions)

Symbol	Parameter	Conditions	-90		-12		Unit
			Min	Max	Min	Max	
t <sub>ISCCF</sub>	TCK Clock Frequency (except for PLD)	(Note 1)		15		12	MHz
t <sub>ISCH</sub>	TCK Clock High Time	(Note 1)	30		40		ns
t <sub>ISCL</sub>	TCK Clock Low Time	(Note 1)	30		40		ns
t <sub>ISCCF-P</sub>	TCK Clock Frequency (for PLD only)	(Note 2)		2		2	MHz
t <sub>ISCH-P</sub>	TCK Clock High Time (for PLD only)	(Note 2)	240		240		ns
t <sub>ISCL-P</sub>	TCK Clock Low Time (for PLD only)	(Note 2)	240		240		ns
t <sub>ISCP<sub>SU</sub></sub>	ISC Port Set Up Time		11		12		ns
t <sub>ISCP<sub>H</sub></sub>	ISC Port Hold Up Time		5		5		ns
t <sub>ISCP<sub>CO</sub></sub>	ISC Port Clock to Output			26		32	ns
t <sub>ISCP<sub>ZV</sub></sub>	ISC Port High-Impedance to Valid Output			26		32	ns
t <sub>ISCP<sub>VZ</sub></sub>	ISC Port Valid Output to High-Impedance			26		32	ns

**NOTES:** 1. For “non-PLD” programming, erase or in ISC by-pass mode.

2. For program or erase PLD only.

Figure 33. Read Timing

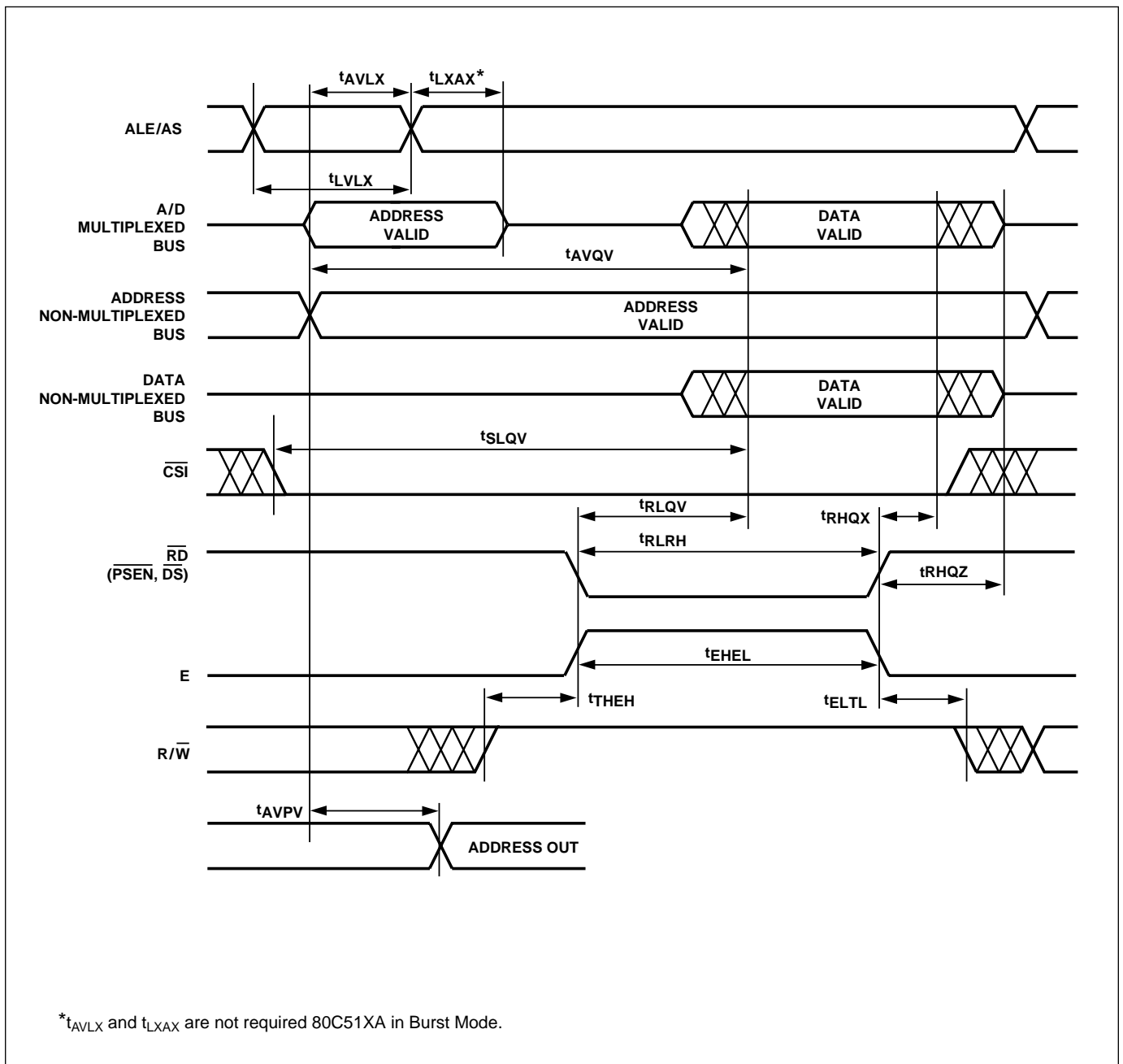

Figure 34. Write Timing

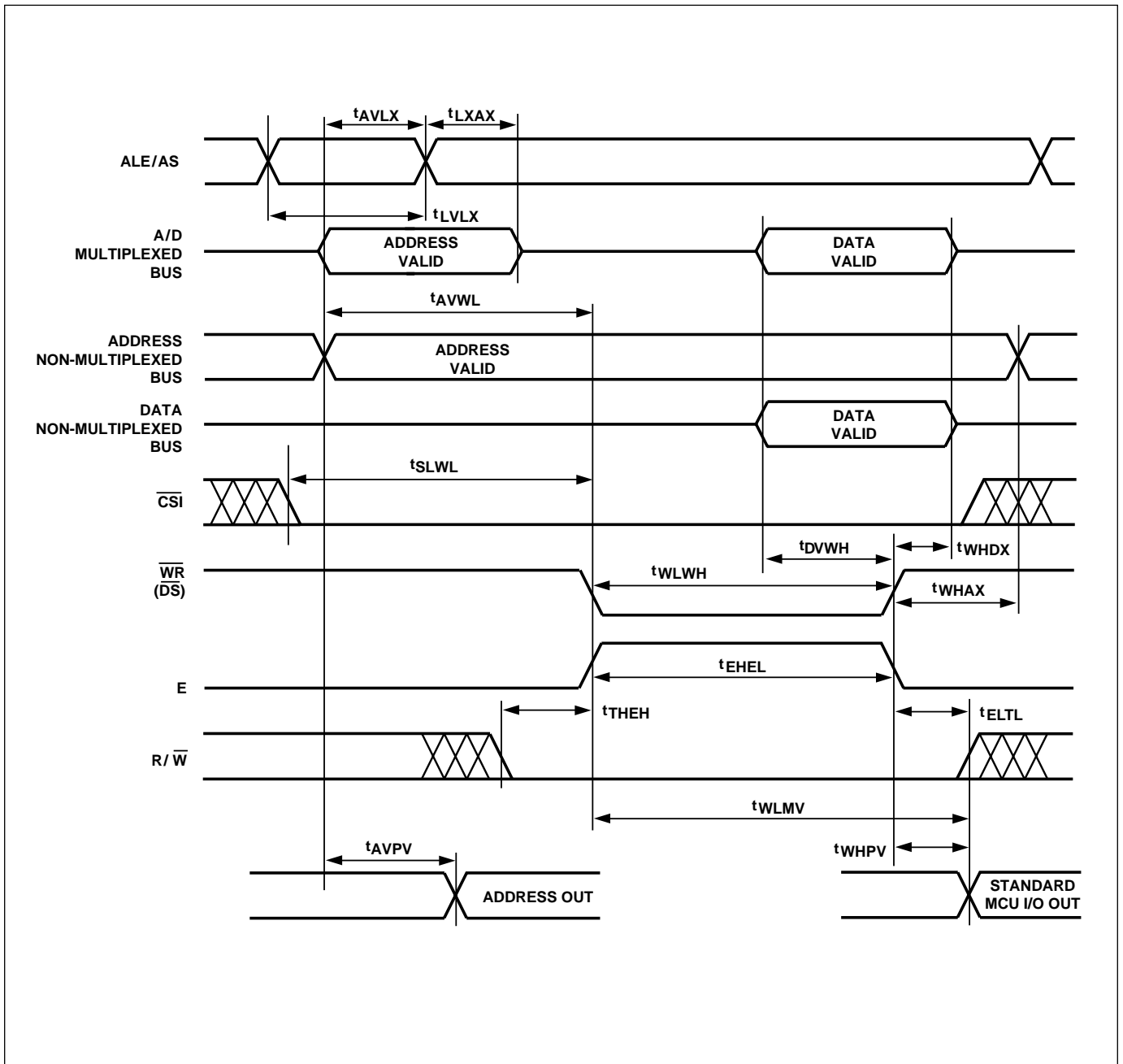

Figure 35. Peripheral I/O Read Timing

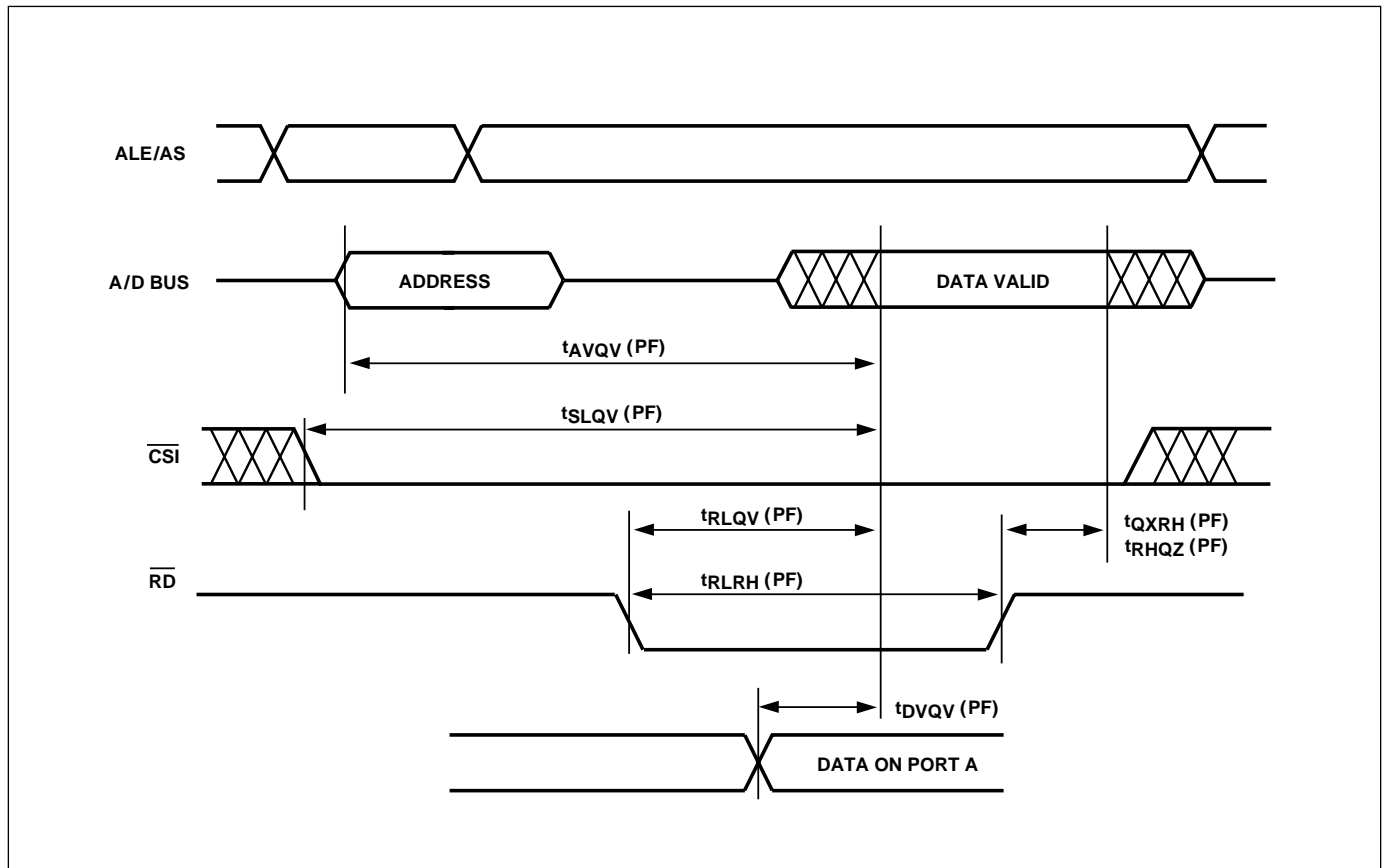

Figure 36. Peripheral I/O Write Timing

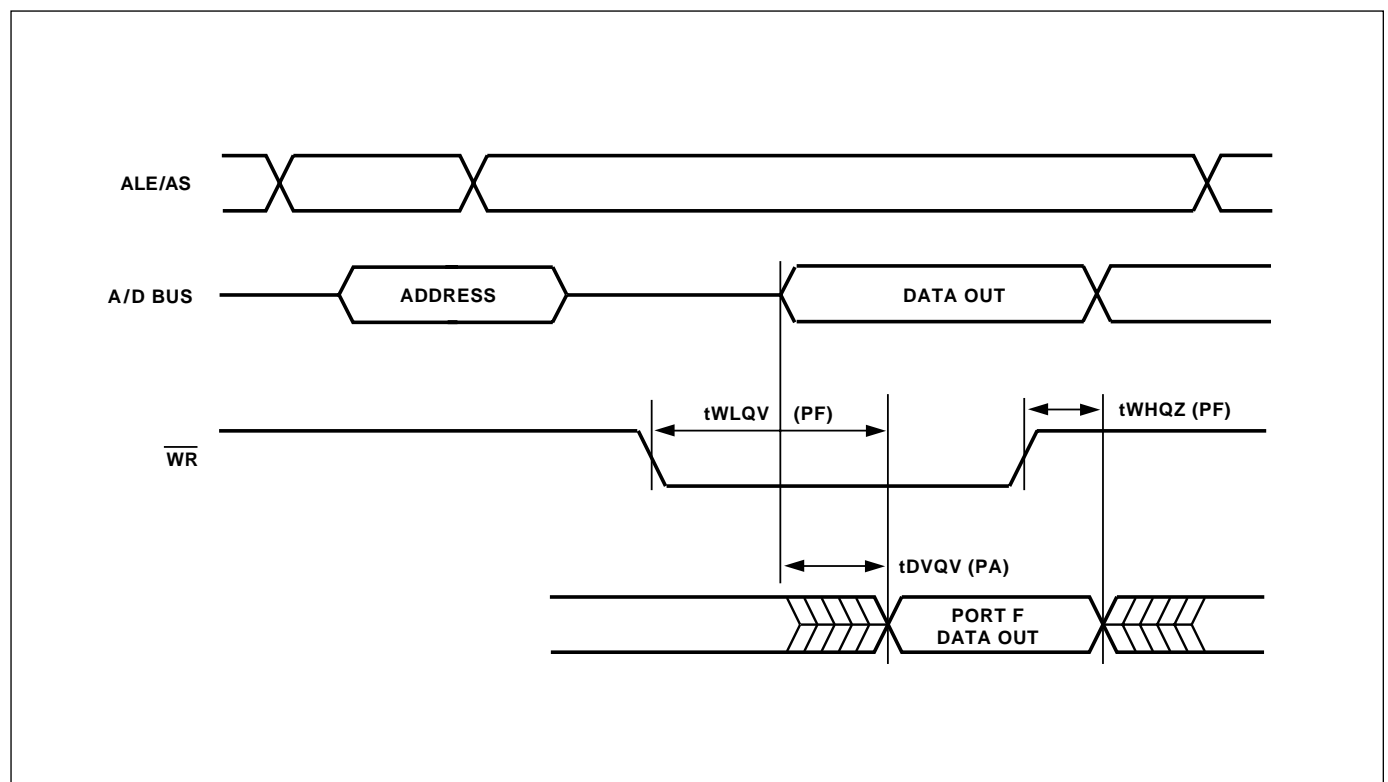

Figure 37. Combinatorial Timing – PLD

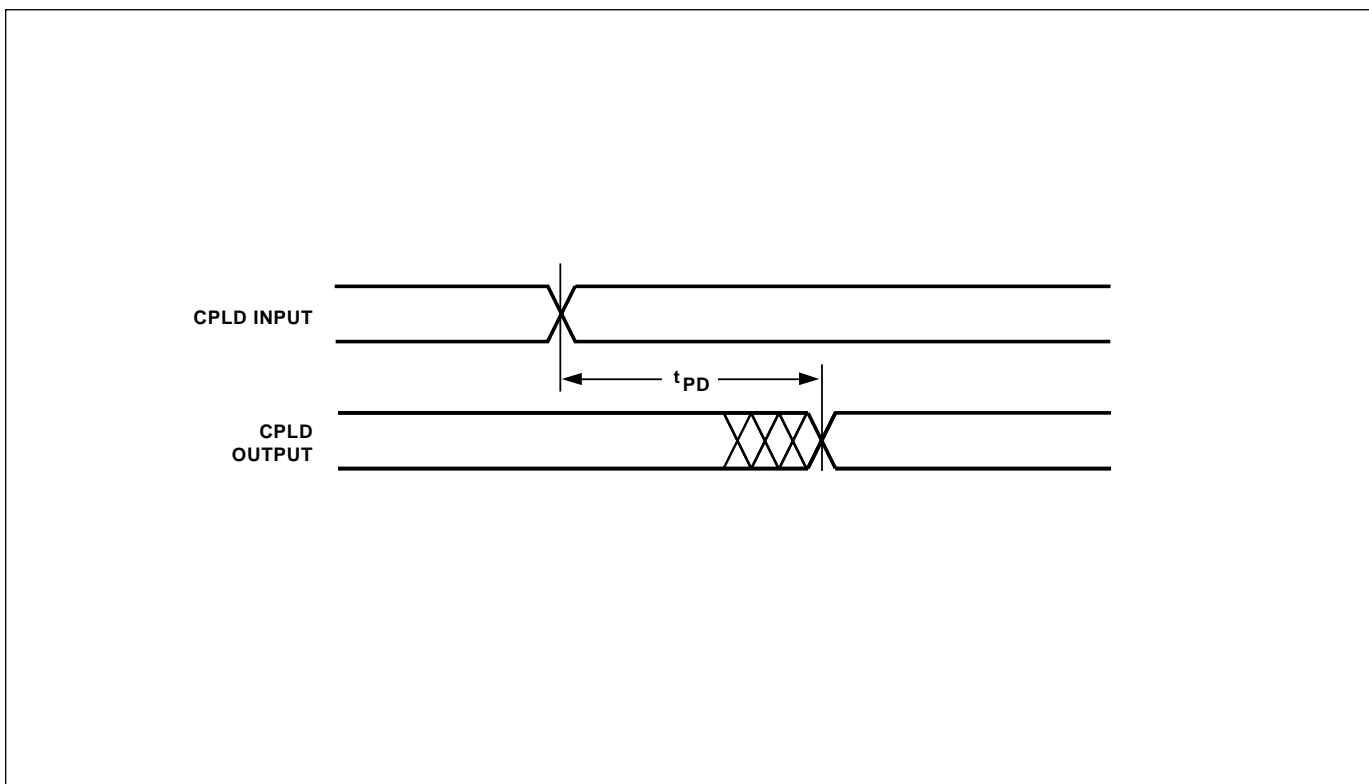

Figure 38. Synchronous Clock Mode Timing – PLD

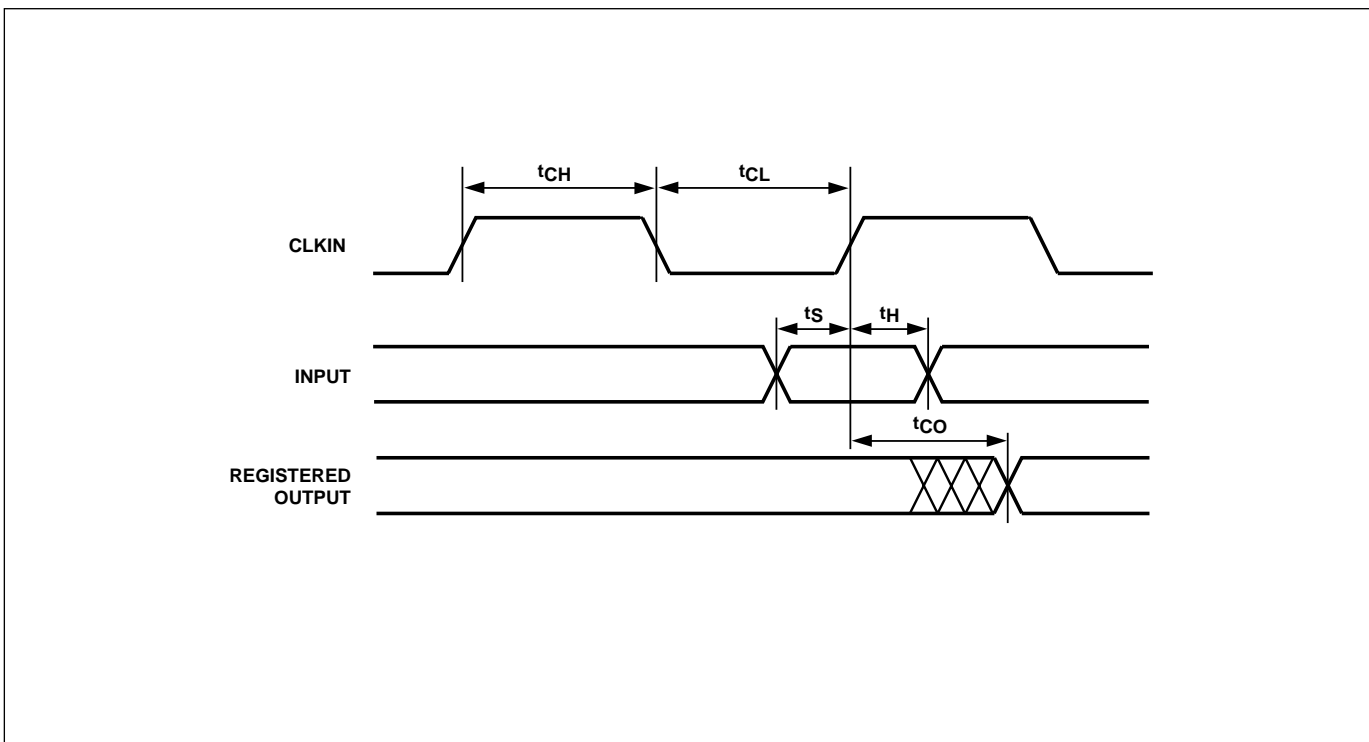

Figure 39. Asynchronous Clock Mode Timing (Product-Term Clock)

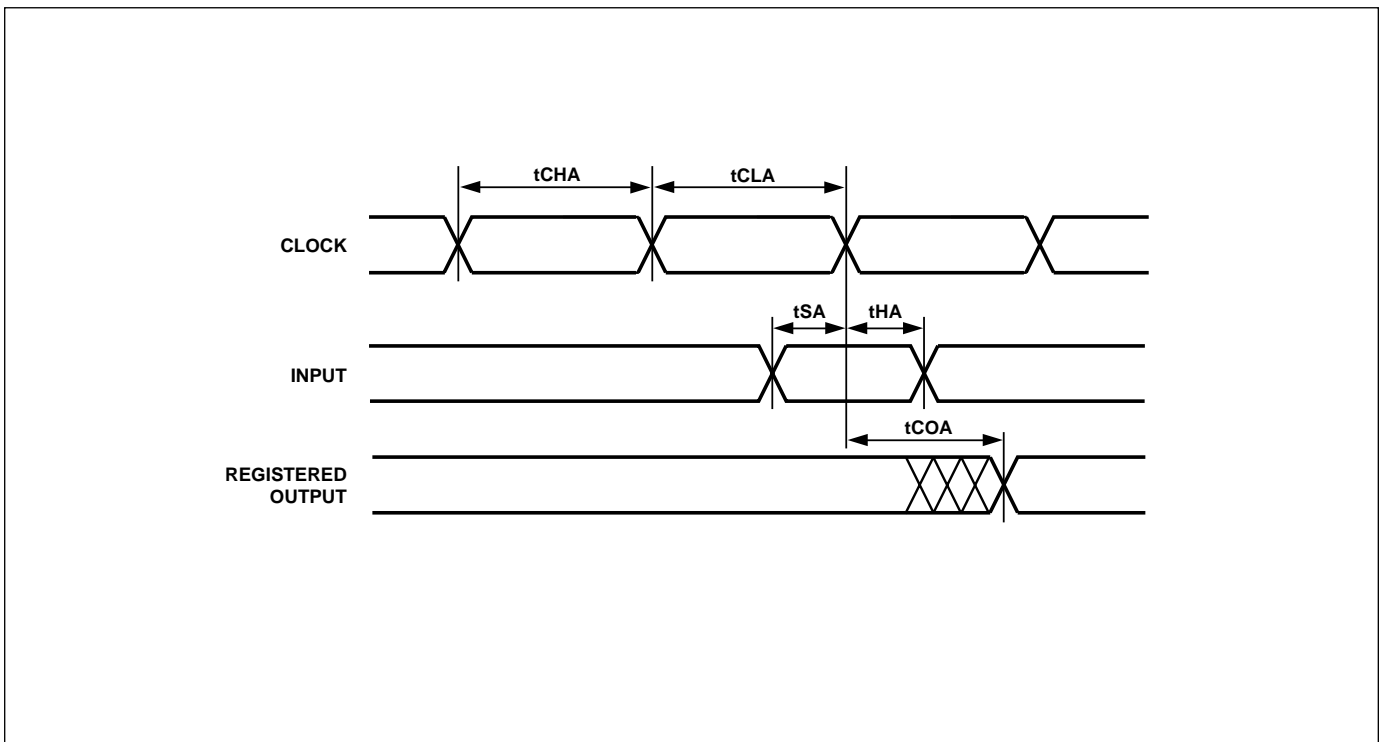

Figure 40. Input Micro↔Cell Timing (Product-Term Clock)

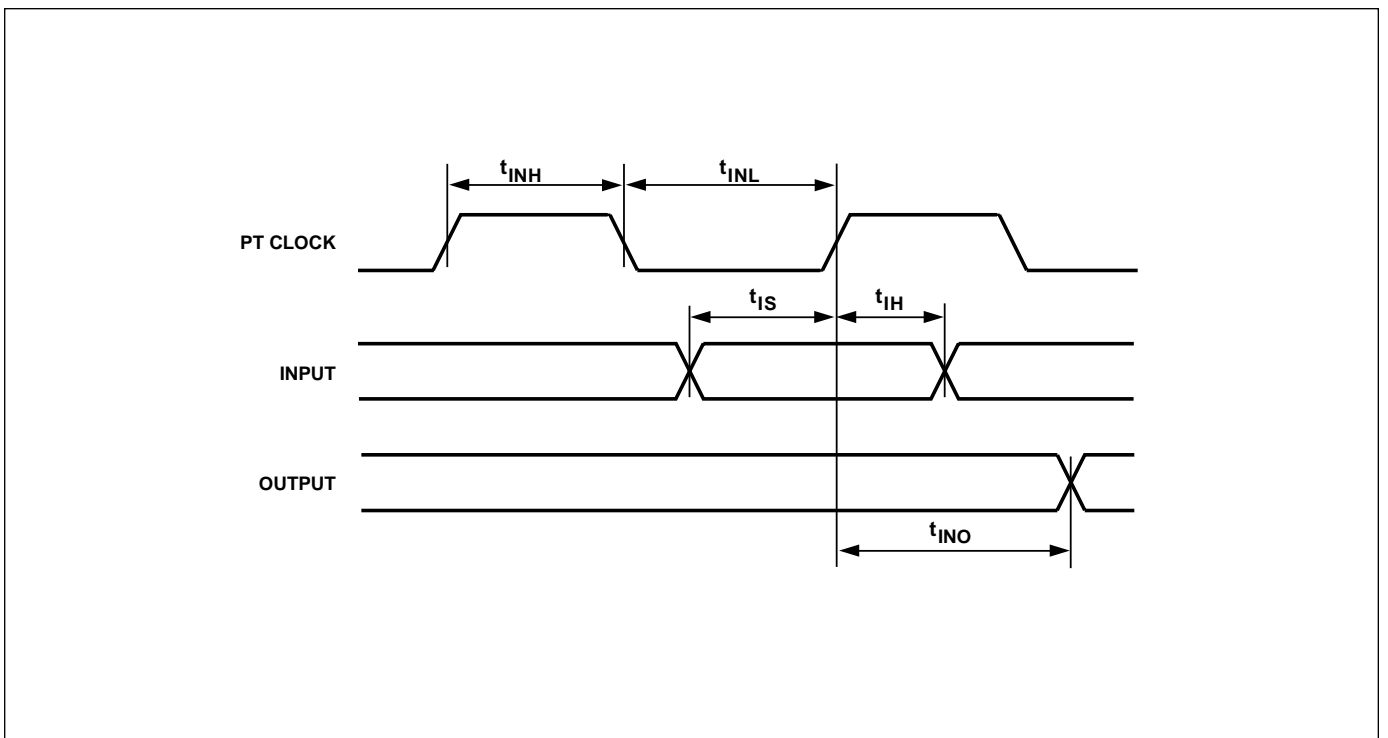

Figure 41. Input to Output Disable/Enable

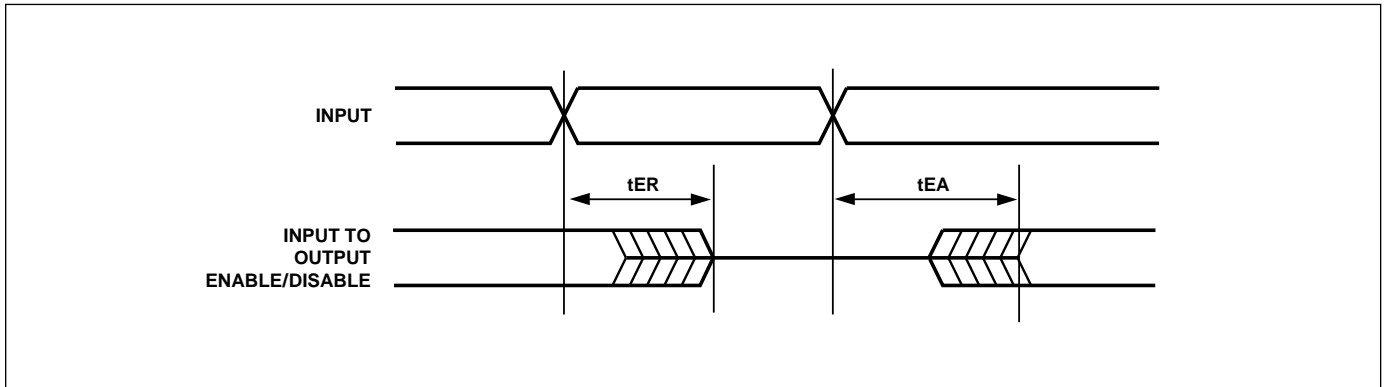

Figure 42. Asynchronous Reset/Preset

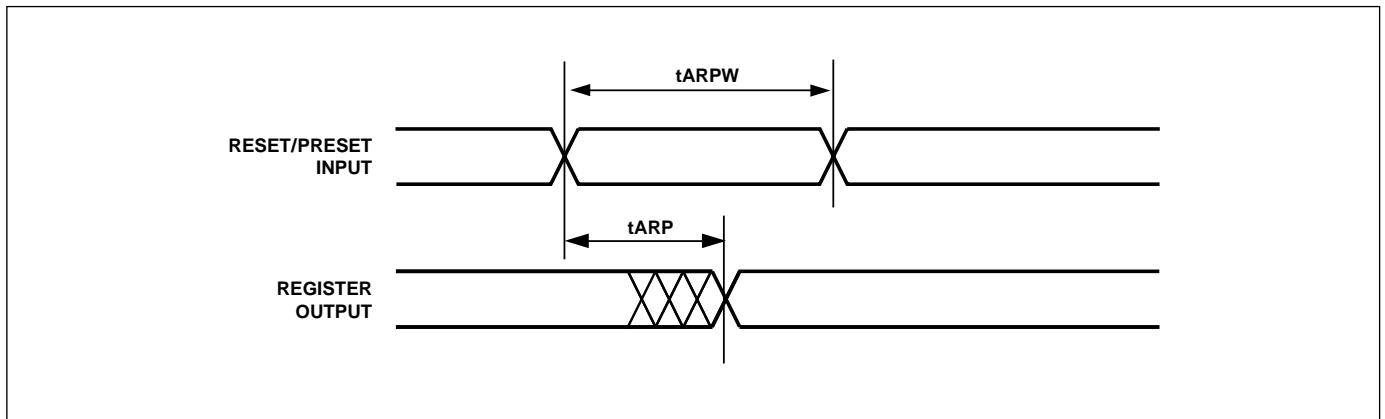

Figure 43. ISC Timing

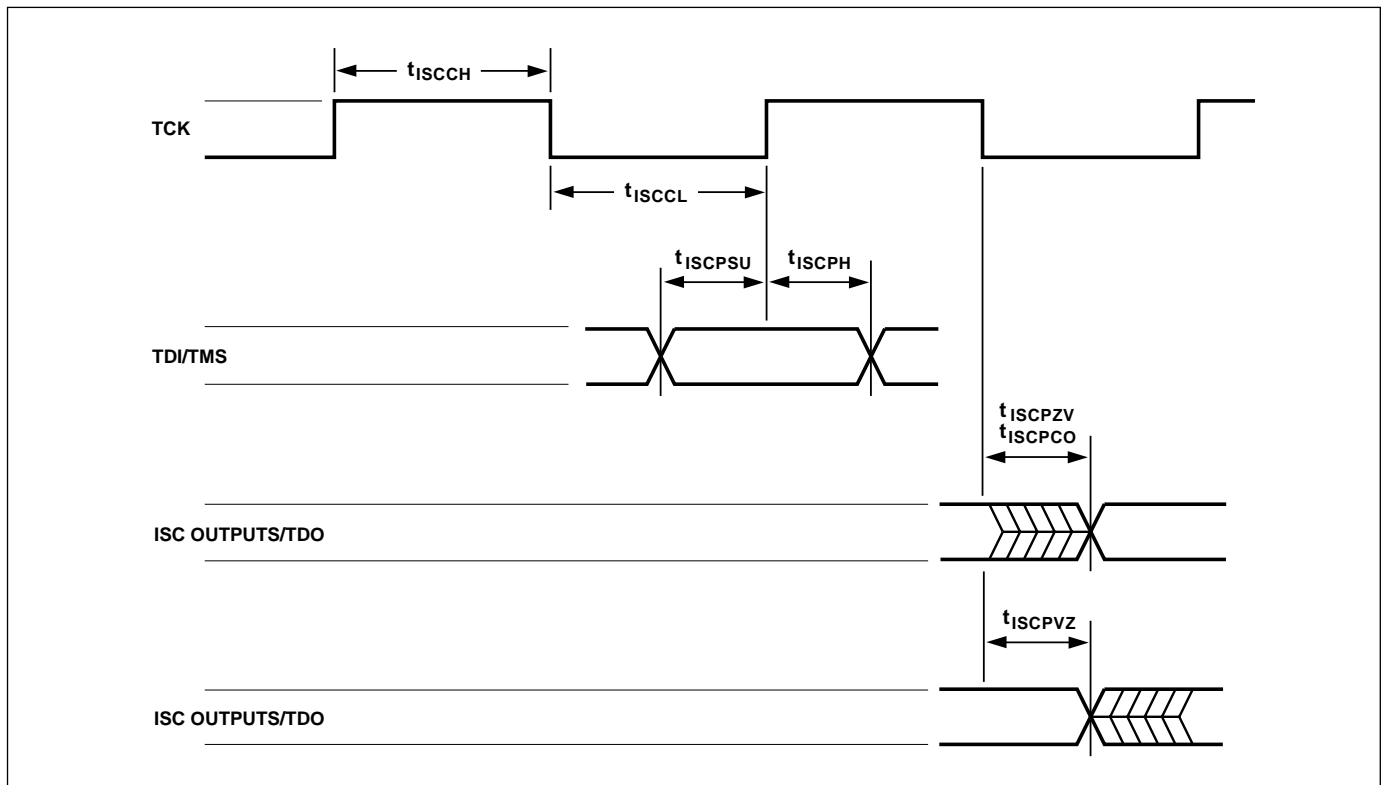

Figure 44. Reset Timing

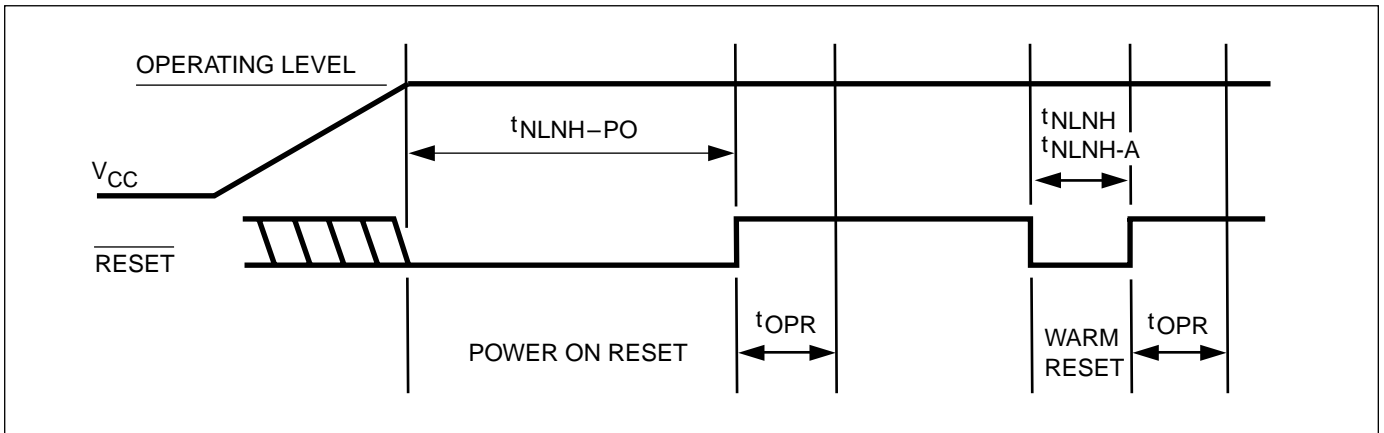

Figure 45. Key to Switching Waveforms

WAVEFORMS	INPUTS	OUTPUTS
	STEADY INPUT	STEADY OUTPUT
	MAY CHANGE FROM HI TO LO	WILL BE CHANGING FROM HI TO LO
	MAY CHANGE FROM LO TO HI	WILL BE CHANGING LO TO HI
	DON'T CARE	CHANGING, STATE UNKNOWN
	OUTPUTS ONLY	CENTER LINE IS TRI-STATE

14.0  
Pin Capacitance

$T_A = 25\text{ }^\circ\text{C}$ ,  $f = 1\text{ MHz}$

Symbol	Parameter <sup>1</sup>	Conditions	Typical <sup>2</sup>	Max	Unit
$C_{IN}$	Capacitance (for input pins only)	$V_{IN} = 0\text{ V}$	4	6	pF
$C_{OUT}$	Capacitance (for input/output pins)	$V_{OUT} = 0\text{ V}$	8	12	pF
$C_{VPP}$	Capacitance (for CNTL2/ $V_{PP}$ )	$V_{PP} = 0\text{ V}$	18	25	pF

**NOTES:** 1. These parameters are only sampled and are not 100% tested.  
2. Typical values are for  $T_A = 25\text{ }^\circ\text{C}$  and nominal supply voltages.

15.0  
Figure 46.  
AC Testing  
Input/Output  
Waveform

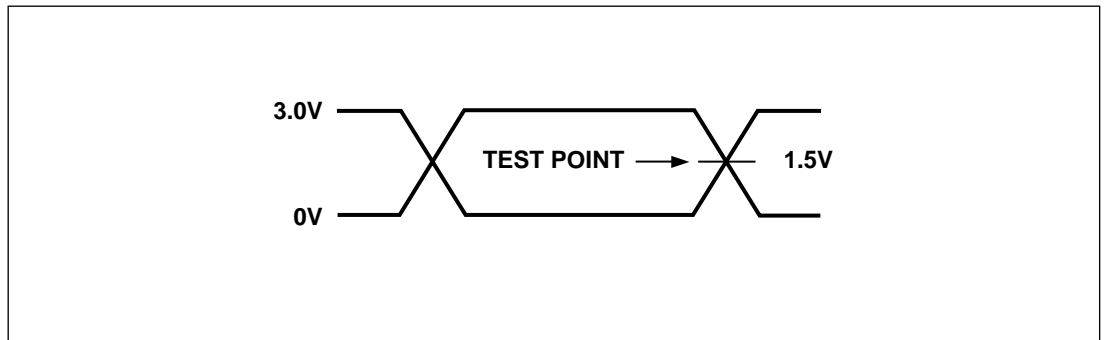

16.0  
Figure 47.  
AC Testing  
Load Circuit

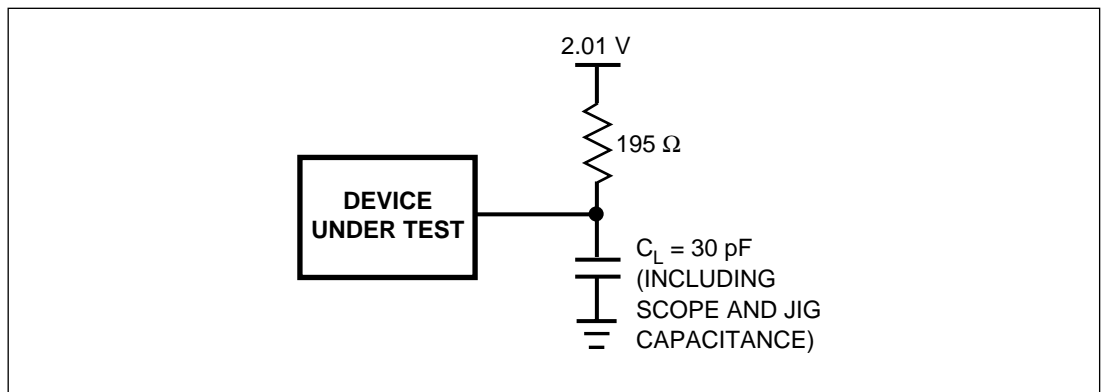

17.0  
Programming

Upon delivery from ST, the PSD835G2 device has all bits in the PLDs and memories in the “1” or high state. The configuration bits are in the “0” or low state. The code, configuration, and PLDs logic are loaded through the procedure of programming.

Information for programming the device is available directly from ST. Please contact your local sales representative. (See the last page.)

18.0  
PSD835G2  
Pin  
Assignments

80-Pin Plastic Thin Quad Flatpack (TQFP) (Package Type U)

Pin No.	Pin Assignments	Pin No.	Pin Assignments
1	PD2	41	PC0
2	PD3	42	PC1
3	AD0	43	PC2
4	AD1	44	PC3
5	AD2	45	PC4
6	AD3	46	PC5
7	AD4	47	PC6
8	GND	48	PC7
9	V <sub>CC</sub>	49	GND
10	AD5	50	GND
11	AD6	51	PA0
12	AD7	52	PA1
13	AD8	53	PA2
14	AD9	54	PA3
15	AD10	55	PA4
16	AD11	56	PA5
17	AD12	57	PA6
18	AD13	58	PA7
19	AD14	59	CNTL0
20	AD15	60	CNTL1
21	PG0	61	PB0
22	PG1	62	PB1
23	PG2	63	PB2
24	PG3	64	PB3
25	PG4	65	PB4
26	PG5	66	PB5
27	PG6	67	PB6
28	PG7	68	PB7
29	V <sub>CC</sub>	69	V <sub>CC</sub>
30	GND	70	GND
31	PF0	71	PE0
32	PF1	72	PE1
33	PF2	73	PE2
34	PF3	74	PE3
35	PF4	75	PE4
36	PF5	76	PE5
37	PF6	77	PE6
38	PF7	78	PE7
39	RESET	79	PD0
40	CNTL2	80	PD1

19.0  
PSD835G2  
Package  
Information

Figure 48. Drawing U5 – 80-Pin Plastic Thin Quad Flatpack (TQFP)  
(Package Type U)

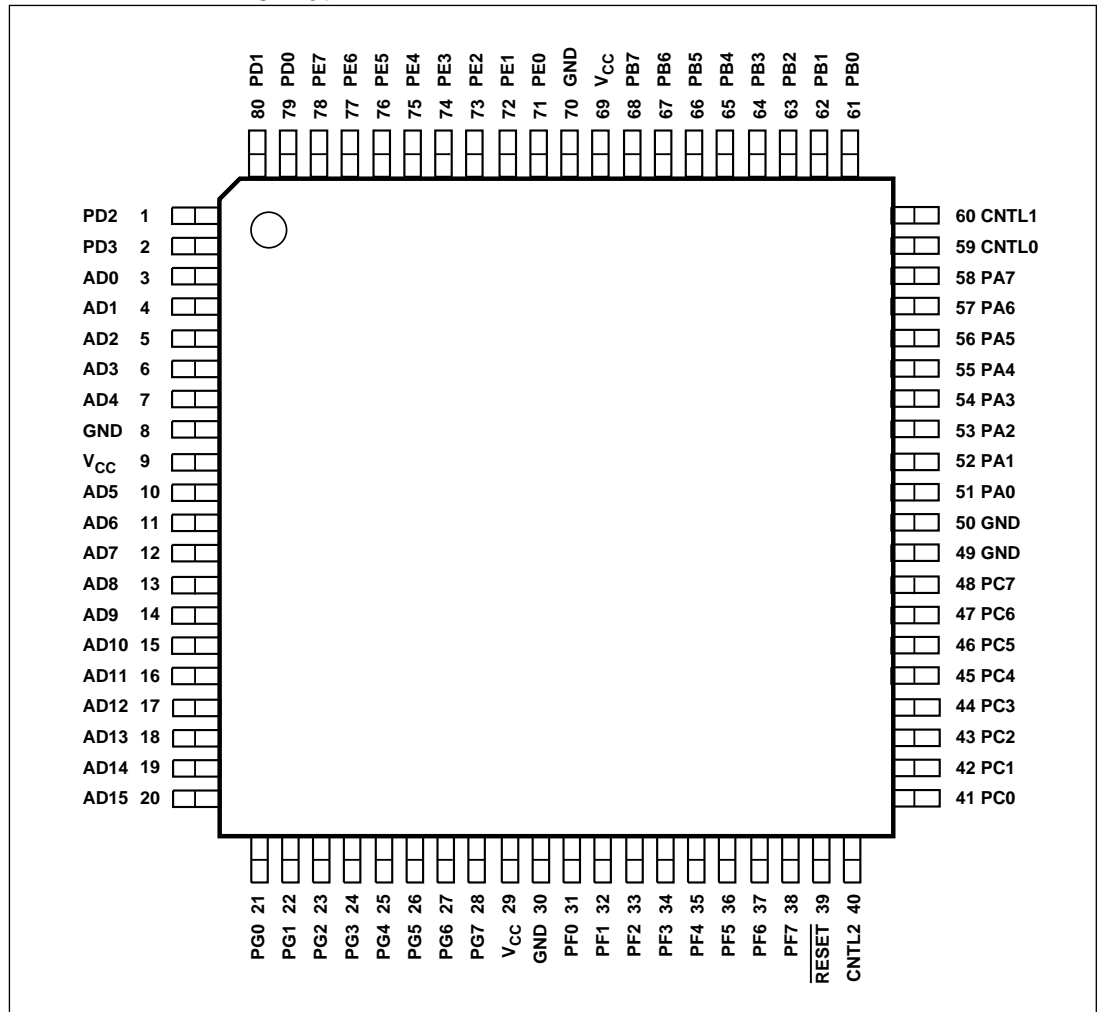
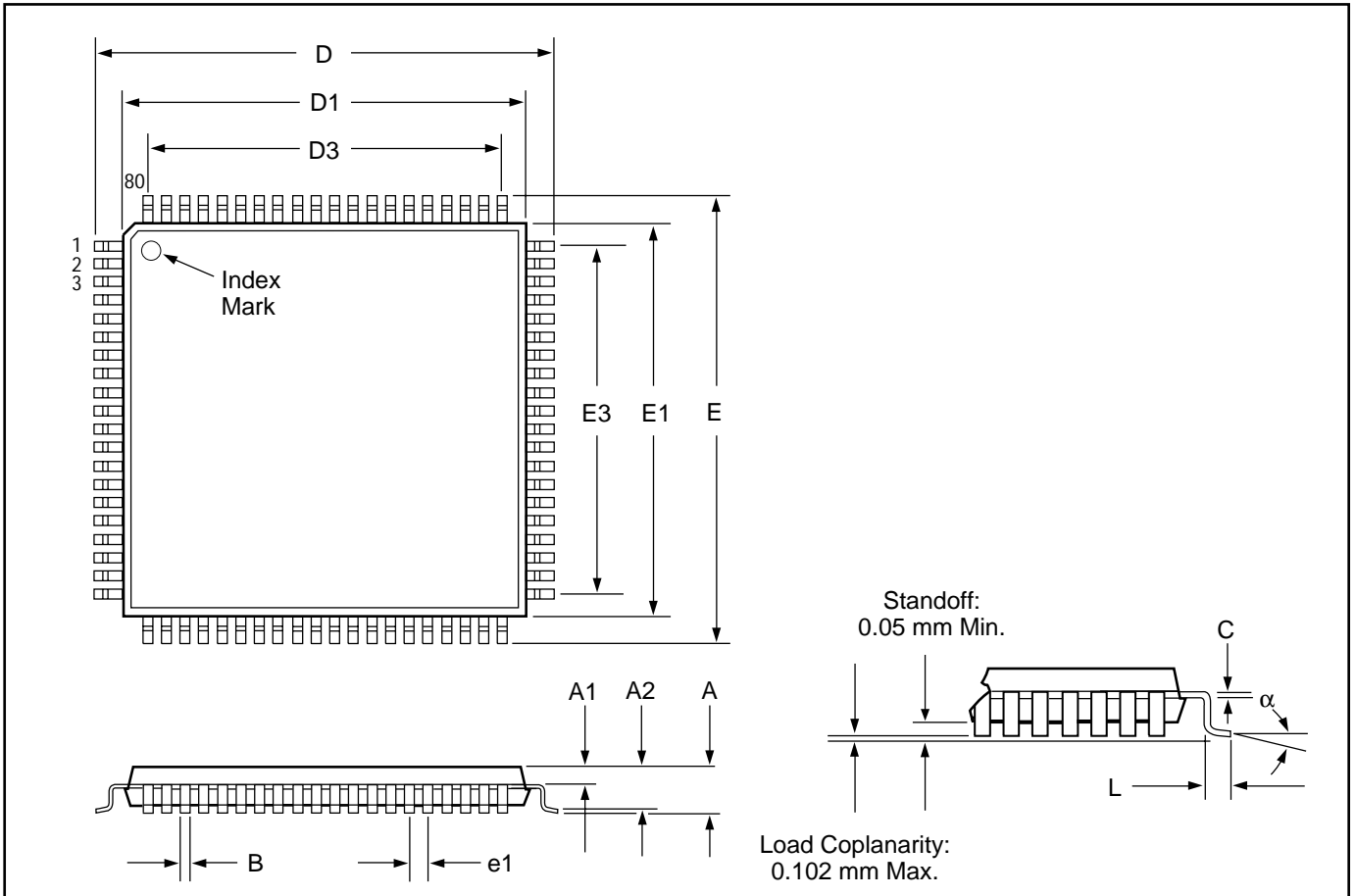

Figure 48A.  
Drawing U5 – 80-Pin Plastic Thin Quad Flatpack (TQFP) (Package Type U)



Family: Plastic Thin Quad Flatpack (TQFP)

Symbol	Millimeters			Inches		
	Min	Max	Notes	Min	Max	Notes
$\alpha$	0°	7°		0°	8°	
A	–	1.20		–	0.047	
A2	0.95	1.05		0.037	0.041	
B	0.17	0.27	Reference	0.007	0.011	
C		0.20			0.008	
D	13.95	14.05		0.512	0.551	
D1	11.95	12.05		0.433	0.472	
D3	9.5		Reference	0.374		Reference
E	13.95	14.05		0.512	0.551	
E1	11.95	12.05		0.433	0.472	
E3	9.5		Reference	0.374		Reference
e1	0.50		Reference	0.019		Reference
L	0.45	0.75		0.018	0.030	
N	80			80		

20.0  
Selector Guide

Selector Guide – PSD8XX Series

Part #	MCU	PLDs/Decoders		I/O	Memory		Other				Software						
		Inputs	Output Macrocells		Flash Program Store	2nd Flash Array	ISP via JTAG	IAP via MCU	Zero Power	Per. Mode		Security	PMU	APD			
5 Volts	Data Path	Output Macrocells		Ports	EEPROM						PSDsoft Express						
			Page Reg.		SRAM w/BB					PSDsoft 2000							
PSD835G2	8	24	24	52	4096Kb	256Kb	-	64Kb	X	X	-	X	X	X	X	X	
PSD813F2	8	73	24	16	1024Kb	256Kb	-	16Kb	X	X	-	X	X	X	X	X	X
PSD834F2	8	73	24	16	2048Kb	256Kb	-	64Kb	X	X	-	X	X	X	X	X	X
PSD833F2	8	73	24	16	2048Kb	256Kb	-	64Kb	X	X	-	X	X	X	X	X	X



### 21.0 Part Number Construction

**Flash PSD Part Number Construction**

CHARACTER #	1	2	3	4	5	6	7	8	9	10	11	12	13	14	15	16	17	18	19
<b>PART NUMBER</b>	P	S	D	4	2	1	3	F	2			-	A	-	1	5	J		
<b>PSD BRAND NAME</b> PSD = Standard Low Power Device																			
<b>FAMILY/SERIES</b> 8 = Flash PSD for 8-bit MCUs  41 = Flash PSD for 16-bit MUCs (with simple PLD)  42 = Flash PSD for 16-bit MUCs (with CPLD)																			
<b>SRAM SIZE</b> 0 = 0Kb 1 = 16Kb 2 = 32Kb 3 = 64Kb																			
<b>NVM SIZE</b> 1 = 256Kb 2 = 512Kb 3 = 1Mb 4 = 2Mb 5 = 4Mb																			
<b>I/O COUNT &amp; OTHER</b> F = 27 I/O G = 52 I/O																			
<b>2ND NVM TYPE, SIZE &amp; CONFIGURATION</b> 1 = EEPROM, 256Kb 2 = FLASH, 256Kb 3 = No 2nd Array																			
<b>TEMP RANGE</b> "Blank" = 0°C to +70°C (Commercial) I = -40°C to +85°C (Industrial)																			
<b>PACKAGE TYPE</b> J = PLCC U = TQFP M = PQFP B81 = BGA																			
<b>SPEED</b> - 70 = 70ns - 90 = 90ns - 12 = 120ns - 15 = 150ns - 20 = 200ns																			
<b>REVISION</b> "Blank" = no rev. - A = Rev. A - B = Rev. B - C = Rev. C																			
<b>V<sub>CC</sub> VOLTAGE</b> "blank" = 5 Volt V = 3.0 Volt																			

### 22.0 Ordering Information

Part Number	Speed (ns)	Package Type	Operating Temperature Range
PSD835G2-70U	70	80 Pin TQFP	Comm'l
PSD835G2-90U	90	80 Pin TQFP	Comm'l
PSD835G2-90UI	90	80 Pin TQFP	Industrial
PSD835G2V-90U	90	80 Pin TQFP	Comm'l
PSD835G2V-12U	120	80 Pin TQFP	Comm'l
PSD835G2V-12UI	120	80 Pin TQFP	Industrial

## PSD835G2

---

### REVISION HISTORY

**Table 1. Document Revision History**

<b>Date</b>	<b>Rev.</b>	<b>Description of Revision</b>
01-Mar-2000	1.0	PSD835G2: Document written in the WSI format. Initial release
30-Nov-2000	1.1	Page 78: changed Turbo Off from add 10 to add 12, changed tCO -70 Max from 13 to 15. Page 79: changed Turbo Off from add 10 to add 12, changed tHA -70 Min from 5 to 7, changed tCLA - 70 Min from 9 to 12, changed tCLA - 90 Min from 12 to 15. Page 81: changed Turbo Off from add 10 to add 12, changed tLXAX -70 Min from 5 to 7. Page 82: changed tLXAX -70 Min from 5 to 7, changed tDVWH -70 Min from 12 to 25, changed tWLWH -70 Min from 25 to 28. Page 83: changed Turbo Off from add 10 to add 12.
31-Jan-2002	1.2	PSD835G2: Configurable Memory System on a Chip for 8-Bit Microcontrollers Front page, and back two pages, in ST format, added to the PDF file Any references to Waferscale, WSI, EasyFLASH and PSDsoft 2000 updated to ST, ST, Flash+PSD and PSDsoft Express

Information furnished is believed to be accurate and reliable. However, STMicroelectronics assumes no responsibility for the consequences of use of such information nor for any infringement of patents or other rights of third parties which may result from its use. No license is granted by implication or otherwise under any patent or patent rights of STMicroelectronics. Specifications mentioned in this publication are subject to change without notice. This publication supersedes and replaces all information previously supplied. STMicroelectronics products are not authorized for use as critical components in life support devices or systems without express written approval of STMicroelectronics.

The ST logo is registered trademark of STMicroelectronics  
All other names are the property of their respective owners

© 2002 STMicroelectronics - All Rights Reserved

STMicroelectronics group of companies Australia - Brazil - Canada - China - Finland - France - Germany - Hong Kong -  
India - Israel - Italy - Japan - Malaysia - Malta - Morocco - Singapore - Spain - Sweden - Switzerland - United Kingdom - United States.

[www.st.com](http://www.st.com)