

FAIRCHILD
SEMICONDUCTOR™

January 1988
Revised July 1999

74F843 9-Bit Transparent Latch

General Description

The 74F843 bus interface latch is designed to eliminate the extra packages required to buffer existing latches and provide extra data width for wider address/data paths or buses carrying parity.

Features

- 3-STATE output

Ordering Code:

Order Number	Package Number	Package Description
74F843SC	M24B	24-Lead Small Outline Integrated Circuit (SOIC), JEDEC MS-013, 0.300 Wide
74F843SPC	N24C	24-Lead Plastic Dual-In-Line Package (PDIP), JEDEC MS-100, 0.300 Wide

Devices also available in Tape and Reel. Specify by appending the suffix letter "X" to the ordering code.

Logic Symbols

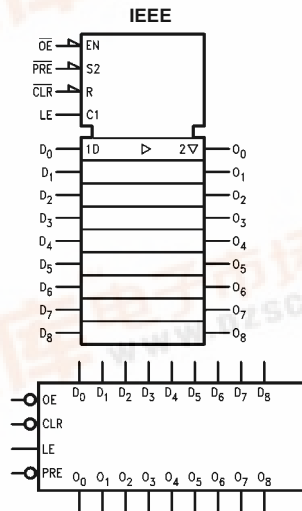

Connection Diagram

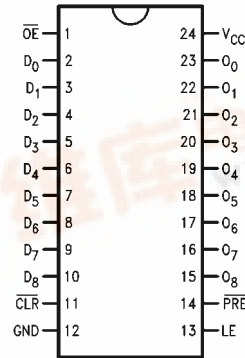

74F843 9-Bit Transparent Latch



Unit Loading/Fan Out

Pin Names	Description	U.L.	
		HIGH/LOW	Input I_{IH}/I_{IL} Output I_{OH}/I_{OL}
D_0-D_8	Data Inputs	1.0/1.0	$20 \mu A/-0.6 \text{ mA}$
\overline{OE}	Output Enable Input	1.0/1.0	$20 \mu A/-0.6 \text{ mA}$
LE	Latch Enable	1.0/1.0	$20 \mu A/-0.6 \text{ mA}$
\overline{CLR}	Clear	1.0/1.0	$20 \mu A/-0.6 \text{ mA}$
\overline{PRE}	Preset	1.0/1.0	$20 \mu A/-0.6 \text{ mA}$
O_0-O_8	3-STATE Data Outputs	150/40	$-3 \text{ mA}/24 \text{ mA}$

Functional Description

The 74F843 consists of nine D-type latches with 3-STATE outputs. The flip-flops appear transparent to the data when Latch Enable (LE) is HIGH. This allows asynchronous operation, as the output transition follows the data in transition. On the LE HIGH-to-LOW transition, the data that meets the setup times is latched. Data appears on the bus when the Output Enable (\overline{OE}) is LOW. When \overline{OE} is HIGH, the bus output is in the high impedance state. In addition to the LE and \overline{OE} pins, the 74F843 has a Clear (CLR) pin and a Preset (\overline{PRE}). These pins are ideal for parity bus interfacing in high performance systems. When CLR is LOW, the outputs are LOW if \overline{OE} is LOW. When \overline{PRE} is HIGH, data can be entered into the latch. When \overline{PRE} is LOW, the Outputs are HIGH if \overline{OE} is LOW. Preset overrides CLR.

Function Table

Inputs					Internal	Output	Function
\overline{CLR}	\overline{PRE}	\overline{OE}	LE	D	Q	O	
H	H	X	X	X	X	Z	High Z
H	H	H	H	L	L	Z	High Z
H	H	H	H	H	H	Z	High Z
H	H	H	L	X	NC	Z	Latched
H	H	L	H	L	L	L	Transparent
H	H	L	H	H	H	H	Transparent
H	H	L	L	X	NC	NC	Latched
H	L	L	X	X	H	H	Preset
L	H	L	X	X	L	L	Clear
L	L	L	X	X	H	H	Preset
L	H	H	L	X	L	Z	Latched
L	L	H	L	X	H	Z	Latched

H = HIGH Voltage Level
 L = LOW Voltage Level
 X = Immaterial
 Z = High Impedance
 NC = No Change

Logic Diagram

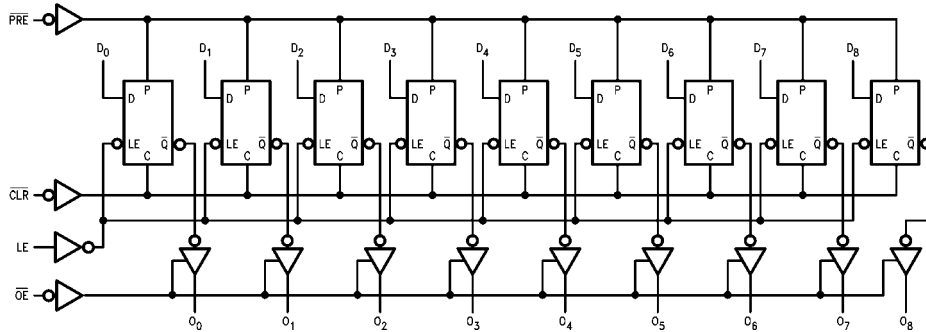

Please note that this diagram is provided only for the understanding of logic operations and should not be used to estimate propagation delays.

Absolute Maximum Ratings(Note 1)

Storage Temperature	-65°C to +150°C
Ambient Temperature under Bias	-55°C to +125°C
Junction Temperature under Bias	-55°C to +150°C
V _{CC} Pin Potential to Ground Pin	-0.5V to +7.0V
Input Voltage (Note 2)	-0.5V to +7.0V
Input Current (Note 2)	-30 mA to +5.0 mA

Voltage Applied to Output

in HIGH State (with V_{CC} = 0V)Standard Output -0.5V to V_{CC}

3-STATE Output -0.5V to +5.5V

Current Applied to Output

in LOW State (Max) twice the rated I_{OL} (mA)**Recommended Operating Conditions**

Free Air Ambient Temperature	0°C to +70°C
Supply Voltage	+4.5V to +5.5V

Note 1: Absolute maximum ratings are values beyond which the device may be damaged or have its useful life impaired. Functional operation under these conditions is not implied.

Note 2: Either voltage limit or current limit is sufficient to protect inputs.

DC Electrical Characteristics

Symbol	Parameter	Min	Typ	Max	Units	V _{CC}	Conditions
V _{IH}	Input HIGH Voltage	2.0			V		Recognized as a HIGH Signal
V _{IL}	Input LOW Voltage			0.8	V		Recognized as a LOW Signal
V _{CD}	Input Clamp Diode Voltage			-1.2	V	Min	I _{IN} = -18 mA
V _{OH}	Output HIGH Voltage	10% V _{CC}	2.5		V	Min	I _{OH} = -1 mA
		10% V _{CC}	2.4	I _{OH} = -3 mA			
		5% V _{CC}	2.7	I _{OH} = -1 mA			
		5% V _{CC}	2.7	I _{OH} = -3 mA			
V _{OL}	Output LOW Voltage	10% V _{CC}		0.5	V	Min	I _{OL} = 24 mA
I _{IH}	Input HIGH Current			5.0	μA	Max	V _{IN} = 2.7V
I _{BVI}	Input HIGH Current Breakdown Test			7.0	μA	Max	V _{IN} = 7.0V
I _{CEX}	Output HIGH Leakage Current			50	μA	Max	V _{OUT} = V _{CC}
V _{ID}	Input Leakage Test	4.75			V	0.0	I _{ID} = 1.9 μA All other pins grounded
I _{OD}	Output Leakage Circuit Current			3.75	μA	0.0	V _{IOD} = 150 mV All other pins grounded
I _{IL}	Input LOW Current			-0.6	mA	Max	V _{IN} = 0.5V
I _{OZH}	Output Leakage Current			50	μA	Max	V _{OUT} = 2.7V
I _{OZL}	Output Leakage Current			-50	μA	Max	V _{OUT} = 0.5V
I _{OS}	Output Short-Circuit Current	-60		-150	mA	Max	V _{OUT} = 0V
I _{ZZ}	Bus Drainage Test			500	μA	0.0V	V _{OUT} = 5.25V
I _{CC}	Power Supply Current		65	90	mA	Max	

AC Electrical Characteristics							
Symbol	Parameter	$T_A = +25^\circ\text{C}$ $V_{CC} = +5.0\text{V}$ $C_L = 50\text{ pF}$			$T_A = 0^\circ\text{C to } +70^\circ\text{C}$ $V_{CC} = +5.0\text{V}$ $C_L = 50\text{ pF}$		Units
		Min	Typ	Max	Min	Max	
t_{PLH}	Propagation Delay D_n to O_n	2.5	5.4	8.0	2.0	9.0	ns
t_{PHL}	Propagation Delay $\overline{D_n}$ to O_n	1.5	4.2	6.5	1.5	7.0	
t_{PLH}	Propagation Delay LE to O_n	5.0	8.5	12.0	4.5	13.5	ns
t_{PHL}	Propagation Delay \overline{LE} to O_n	2.0	4.7	7.5	2.0	8.0	
t_{PLH}	Propagation Delay \overline{PRE} to O_n	3.0	7.3	10.0	2.5	11.0	ns
t_{PHL}	Propagation Delay CLR to O_n	3.0	6.9	10.0	2.5	11.0	
t_{PZH}	Output Enable Time \overline{OE} to O_n	2.5	5.0	8.5	2.0	9.5	ns
t_{PZL}	Output Disable Time \overline{OE} to O_n	2.5	6.1	9.0	2.0	10.0	
t_{PHZ}	Output Enable Time \overline{OE} to O_n	1.0	3.6	6.5	1.0	7.5	ns
t_{PLZ}	Output Disable Time \overline{OE} to O_n	1.0	3.4	6.5	1.0	7.5	
AC Operating Requirements							
Symbol	Parameter	$T_A = +25^\circ\text{C}$ $V_{CC} = +5.0\text{V}$		$T_A = 0^\circ\text{C to } +70^\circ\text{C}$ $V_{CC} = +5.0\text{V}$		Units	
		Min	Max	Min	Max		
$t_S(H)$	Setup Time, HIGH or LOW D_n to LE	2.0		2.5		ns	
$t_S(L)$	Setup Time, HIGH or LOW D_n to LE	2.0		2.5			
$t_H(H)$	Hold Time, HIGH or LOW D_n to LE	2.5		3.0		ns	
$t_H(L)$	Hold Time, HIGH or LOW D_n to LE	3.0		3.5			
$t_W(H)$	LE Pulse Width, HIGH	4.0		4.0		ns	
$t_W(L)$	\overline{PRE} Pulse Width, LOW	5.0		5.0		ns	
$t_W(L)$	CLR Pulse Width, LOW	5.0		5.0		ns	
t_{REC}	\overline{PRE} Recovery Time	10.0		10.0		ns	
t_{REC}	CLR Recovery Time	12.0		13.0		ns	

Physical Dimensions inches (millimeters) unless otherwise noted

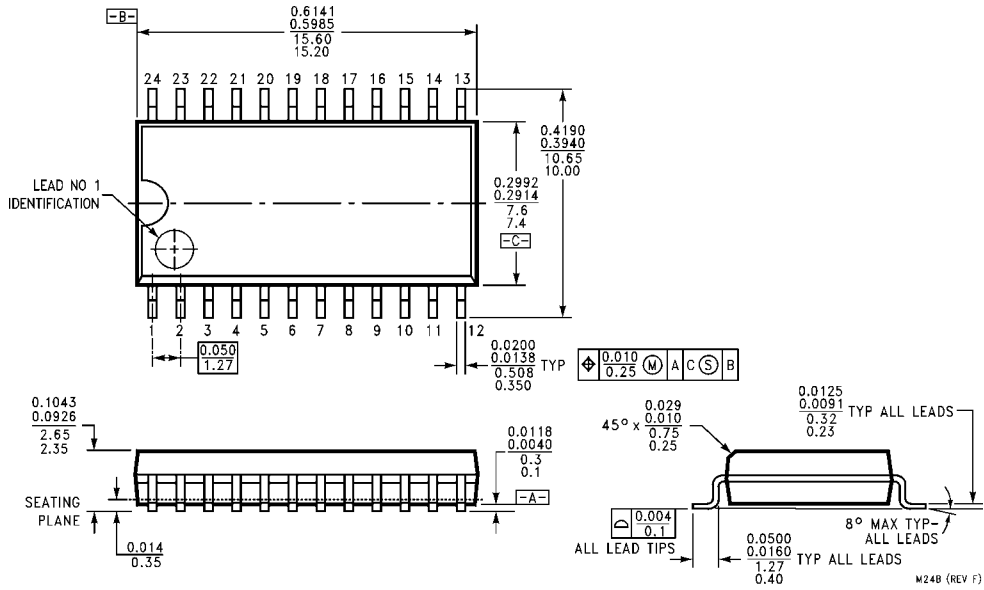

**24-Lead Small Outline Integrated Circuit (SOIC), JEDEC MS-013, 0.300 Wide)
Package Number M24B**

M24B (REV F)

Physical Dimensions inches (millimeters) unless otherwise noted (Continued)

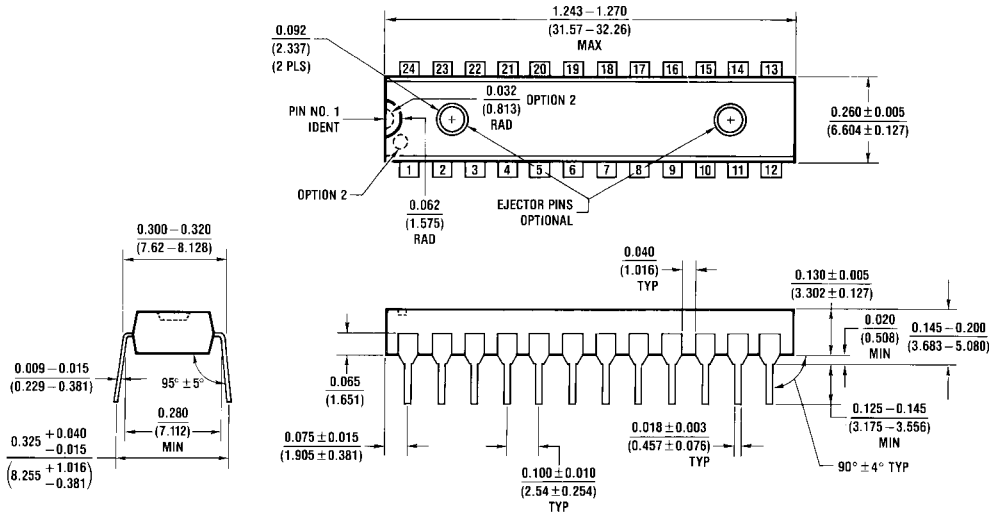

**24-Lead Plastic Dual-In-Line Package (PDIP), JEDEC MS-100, 0.300 Wide
Package Number N24C**

N24C (REV F)

Fairchild does not assume any responsibility for use of any circuitry described, no circuit patent licenses are implied and Fairchild reserves the right at any time without notice to change said circuitry and specifications.

LIFE SUPPORT POLICY

FAIRCHILD'S PRODUCTS ARE NOT AUTHORIZED FOR USE AS CRITICAL COMPONENTS IN LIFE SUPPORT DEVICES OR SYSTEMS WITHOUT THE EXPRESS WRITTEN APPROVAL OF THE PRESIDENT OF FAIRCHILD SEMICONDUCTOR CORPORATION. As used herein:

1. Life support devices or systems are devices or systems which, (a) are intended for surgical implant into the body, or (b) support or sustain life, and (c) whose failure to perform when properly used in accordance with instructions for use provided in the labeling, can be reasonably expected to result in a significant injury to the user.
2. A critical component in any component of a life support device or system whose failure to perform can be reasonably expected to cause the failure of the life support device or system, or to affect its safety or effectiveness.

www.fairchildsemi.com