

### Features

- Glass Passivated Die Construction
- Low Forward Voltage Drop
- High Current Capability
- High Reliability
- High Surge Current Capability
- Ideal for Printed Circuit Boards

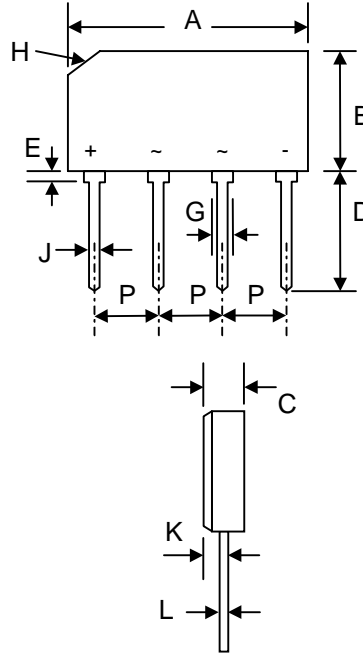

GBL		
Dim	Min	Max
A	19.6	20.6
B	10.7	11.2
C	3.8	4.7
D	15.7	17.3
E	1.65	2.4
G	1.65	2.0
H	3.17 x 45°	
J	0.90	1.14
K	1.14	1.52
L	0.38	0.51
P	4.8	5.3
All Dimensions in mm		

### Mechanical Data

- Case: Molded Plastic
- Terminals: Plated Leads Solderable per MIL-STD-202, Method 208
- Polarity: As Marked on Body
- Weight: 2.0 grams (approx.)
- Mounting Position: Any
- Marking: Type Number

### Maximum Ratings and Electrical Characteristics @ $T_A=25^\circ\text{C}$ unless otherwise specified

Single Phase, half wave, 60Hz, resistive or inductive load.  
For capacitive load, derate current by 20%.

Characteristic	Symbol	GBL 005	GBL 01	GBL 02	GBL 04	GBL 06	GBL 08	GBL 10	Unit
Peak Repetitive Reverse Voltage	$V_{RRM}$								
Working Peak Reverse Voltage	$V_{RWM}$	50	100	200	400	600	800	1000	V
DC Blocking Voltage	$V_R$								
RMS Reverse Voltage	$V_{R(RMS)}$	35	70	140	280	420	560	700	V
Average Rectified Output Current @ $T_C = 50^\circ\text{C}$	$I_o$	4.0							A
Non-Repetitive Peak Forward Surge Current 8.3ms Single half sine-wave superimposed on rated load (JEDEC Method)	$I_{FSM}$	150							A
Forward Voltage (per bridge) @ $I_F = 4.0\text{A}$	$V_{FM}$	1.0							V
Peak Reverse Current @ $T_A = 25^\circ\text{C}$	$I_R$	10							$\mu\text{A}$
At Rated DC Blocking Voltage @ $T_C = 150^\circ\text{C}$		1.0							$\text{mA}$
Typical Thermal Resistance (per leg) (Note 1)	$R_{\theta JA}$	22							$^\circ\text{C/W}$
Typical Thermal Resistance (per leg) (Note 2)	$R_{\theta JC}$	3.5							$^\circ\text{C/W}$
Operating and Storage Temperature Range	$T_j, T_{STG}$	-55 to +150							$^\circ\text{C}$

Note: 1. Thermal resistance junction to ambient, mounted on 7.5 x 7.5 x 0.3cm thick AL plate.  
2. Thermal resistance junction to case, mounted on PCB at 9.5mm lead length.

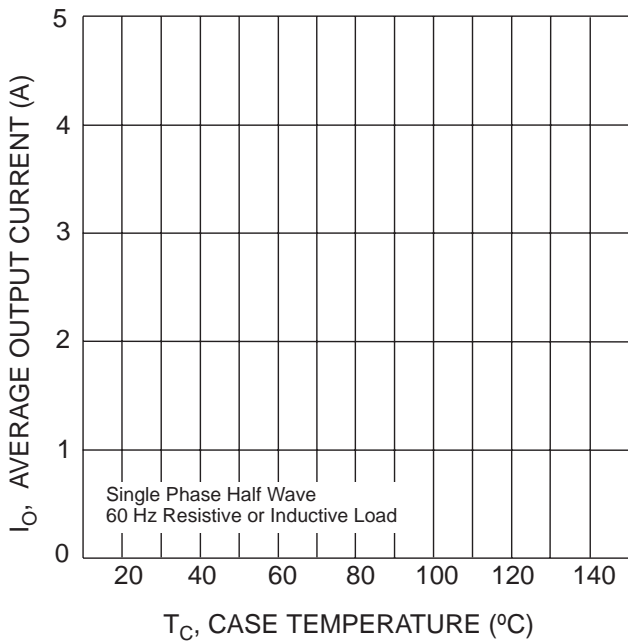

Fig. 1 Forward Current Derating Curve

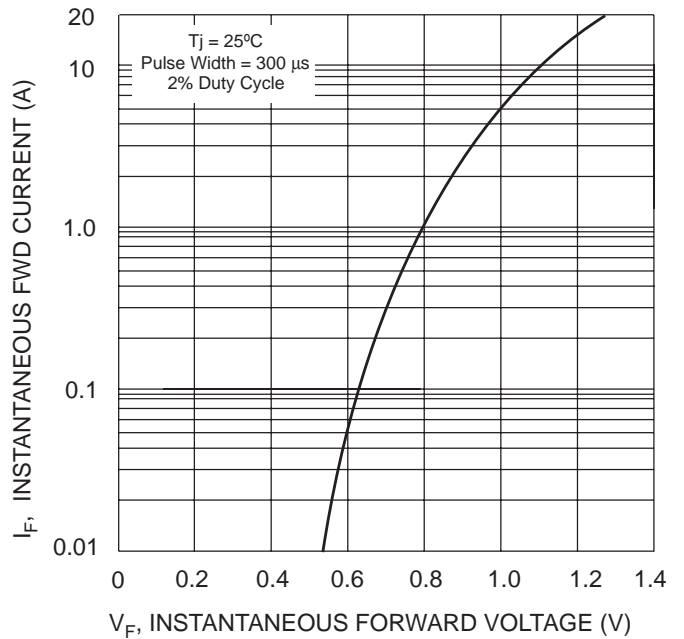

Fig. 2 Typical Forward Characteristics, per element

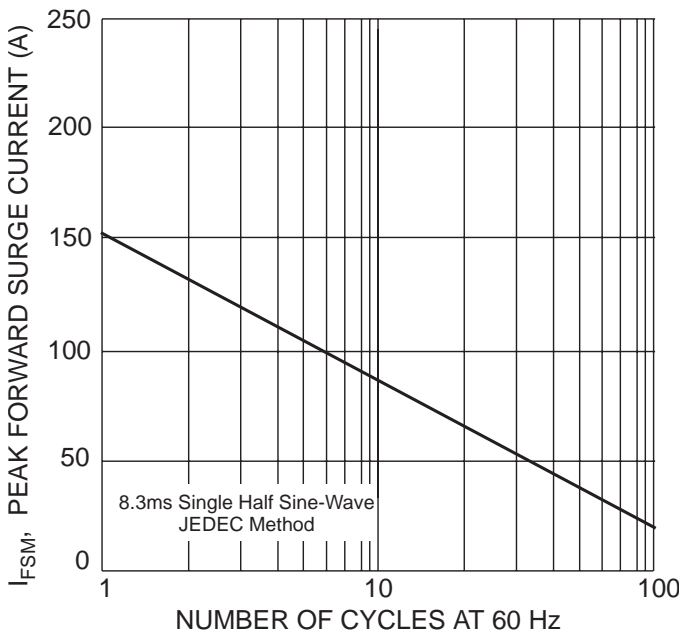

Fig. 3 Max Non-Repetitive Peak Fwd Surge Current

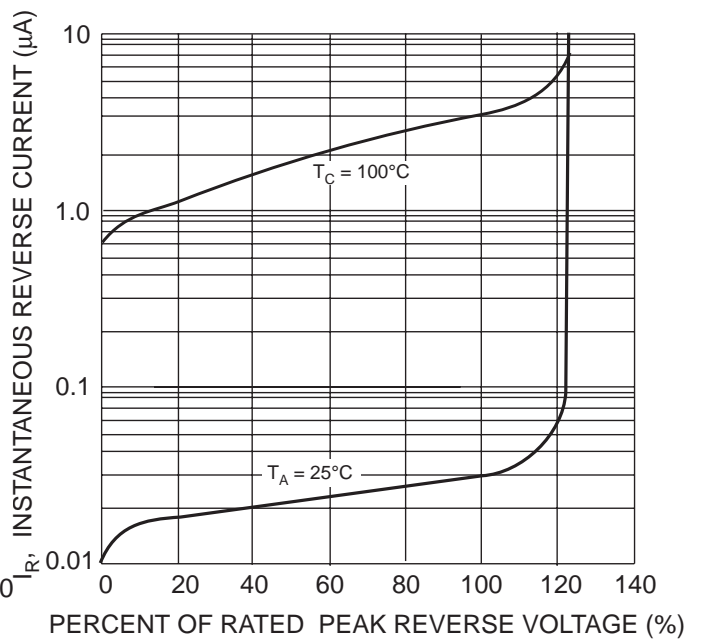

Fig. 4 Typical Reverse Characteristics, per element

## ORDERING INFORMATION

Product No.	Package Type	Shipping Quantity
GBL005	SIL Bridge	500 Units/Box
GBL01	SIL Bridge	500 Units/Box
GBL02	SIL Bridge	500 Units/Box
GBL04	SIL Bridge	500 Units/Box
GBL06	SIL Bridge	500 Units/Box
GBL08	SIL Bridge	500 Units/Box
GBL10	SIL Bridge	500 Units/Box

Shipping quantity given is for minimum packing quantity only. For minimum order quantity, please consult the Sales Department.

Won-Top Electronics Co., Ltd (WTE) has checked all information carefully and believes it to be correct and accurate. However, WTE cannot assume any responsibility for inaccuracies. Furthermore, this information does not give the purchaser of semiconductor devices any license under patent rights to manufacturer. WTE reserves the right to change any or all information herein without further notice.

**WARNING:** DO NOT USE IN LIFE SUPPORT EQUIPMENT. WTE power semiconductor products are not authorized for use as critical components in life support devices or systems without the express written approval.

**Won-Top Electronics Co., Ltd.**

No. 44 Yu Kang North 3rd Road, Chine Chen Dist., Kaohsiung, Taiwan

**Phone:** 886-7-822-5408 or 886-7-822-5410

**Fax:** 886-7-822-5417

**Email:** sales@wontop.com

**Internet:** <http://www.wontop.com>

*We power your everyday.*