

4-Bit Differential ECL Bus/TTL Bus Transceiver

The MC10H/100H680 is a dual supply 4-bit differential ECL bus to TTL bus transceiver. It is designed to allow the system designer to no longer be limited in bus speed associated with standard TTL busses. Using a differential ECL Bus will increase the frequency of operation and increase noise immunity.

Both the TTL and the ECL ports are capable of driving a bus. The ECL outputs have the ability to drive $25\ \Omega$, allowing both ends of the bus line to be terminated in the characteristic impedance of $50\ \Omega$. The TTL outputs are specified to source 15 mA and sink 48 mA, allowing the ability to drive highly capacitive loads.

The ECL output levels are V_{OH} approximately equal to -1.0 V and V_{OL} cutoff equal to -2.0 V (V_{TT}). When the ECL ports are disabled both EIOx and EIOxB go to the V_{OL} cutoff level. The ECL input receivers have special circuitry which detects this disabled condition, prevents oscillation, and forces the TTL output to the low state. The noise margin in this disabled state is greater than 600 mV. Multiple ECL V_{CCO} pins are utilized to minimize switching noise.

The TTL ports have standard levels. The TTL input receivers have PNP input devices to significantly reduce loading. Multiple TTL power and ground pins are utilized to minimize switching noise.

The control pins (EDIR and ECEB) of the 10H version is compatible with MECL 10H ECL logic levels. The control pins of the 100H version are compatible with 100K levels.

- Differential ECL Bus ($25\ \Omega$) I/O Ports
- High Drive TTL Bus I/O Ports
- Extra TTL and ECL Power/Ground Pins to Minimize Switching Noise
- Dual Supply
- Direction and Chip Enable Control Pins

Pinout: 28-Lead PLCC (Top View)

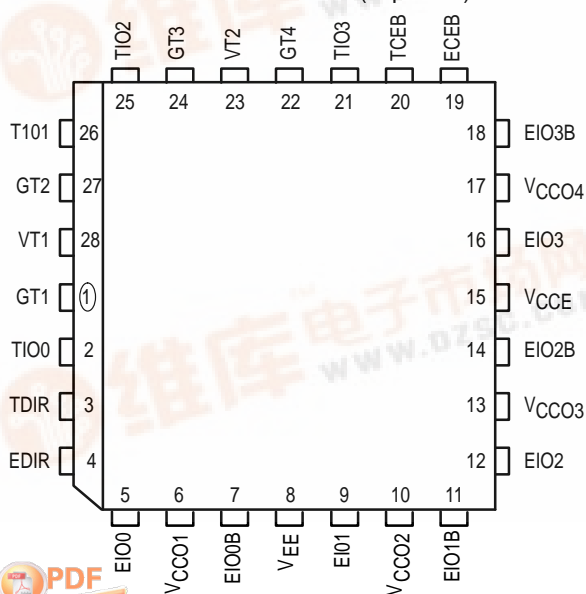

MC10H680
MC100H680

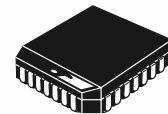

FN SUFFIX
PLASTIC PACKAGE
CASE 776-02

PIN DESCRIPTIONS

Pin	Symbol	Function
1	GT1	TTL Ground 1
2	TIO0	TTL I/O Bit 0
3	TDIR	TTL Direction Control
4	EDIR	ECL Direction Control
5	EIO0	ECL I/O Bit 0
6	VCCO1	ECL VCC 1 (0V) – Outputs
7	EIO0B	ECL I/O Bit 0 Bar
8	VEE	ECL Supply ($-5.2/-4.5\text{V}$)
9	EIO1	ECL I/O Bit 1
10	VCCO2	ECL VCC 2 (0V) – Outputs
11	EIO1B	ECL I/O Bit 1 Bar
12	EIO2	ECL I/O Bit 2
13	VCCO3	ECL VCC 3 (0V) – Outputs
14	EIO2B	ECL I/O Bit 2 Bar
15	VCCE	ECL VCC (0V)
16	EIO3	ECL I/O Bit 3
17	VCCO4	ECL VCC 4 (0V) – Outputs
18	EIO3B	ECL I/O Bit 3 Bar
19	ECEB	ECL Chip Enable Bar Control
20	TCEB	TTL Chip Enable Bar Control
21	TIO3	TTL I/O Bit 3
22	GT4	TTL Ground 4
23	VT2	TTL Supply 2 (5V)
24	GT3	TTL Ground 3
25	TIO2	TTL I/O Bit 2
26	TIO1	TTL I/O Bit 1
27	GT2	TTL Ground 2
28	VT1	TTL Supply 1 (5V)



TRUTH TABLE

TDIR — Direction Control TTL Levels
 EDIR — Direction Control ECL Levels
 TCEB — Chip Enable Bar Control TTL Levels
 ECEB — Chip Enable Bar Control ECL Levels
 TIN — TTL Input
 TOUT — TTL Output
 EIN — ECL Input
 EINB — ECL Input Bar
 EOUT — ECL Output
 EOUTB — ECL Output Bar

H — HIGH
 L — LOW
 LC — ECL Low Cutoff (VTT = -2.0 V)
 X — Don't Care
 Z — High Impedance

ECEB	TCEB	EDIR	TDIR	EIN	EINB	EOUT	EOUTB	TIN	TOUT	COMMENTS
H	X	X	X	X	X	LC	LC	X	Z	ECL and TTL Outputs Disabled
X	H	X	X	X	X	LC	LC	X	Z	ECL and TTL Outputs Disabled
L	L	H	X	H	LC			NA	H	ECL to TTL Direction
L	L	H	X	LC	H			NA	L	ECL to TTL Direction
L	L	H	X	LC	LC			NA	L	ECL to TTL Direction (L-L Cond.)
L	L	X	H	H	LC			NA	H	ECL to TTL Direction
L	L	X	H	LC	H			NA	L	ECL to TTL Direction
L	L	X	H	LC	LC			NA	L	ECL to TTL Direction (L-L Cond.)
L	L	L	L	NA	NA	H	LC	H		TTL to ECL Direction
L	L	L	L	NA	NA	LC	H	L		TTL to ECL Direction

ABSOLUTE RATINGS (Do not exceed):

Power Supply Voltage	V_{EE} (ECL)	-8.0 to 0	Vdc
Power Supply Voltage	V_{CCT} (TTL)	-0.5 to +7.0	Vdc
Input Voltage	V_I (ECL) V_I (TTL)	0.0 to V_{EE} -0.5 to +7.0	Vdc
Disabled 3-State Output	V_{out} (TTL)	0.0 to V_{CCT}	Vdc
Output Source Current Continuous	I_{out} (ECL)	100	mAdc
Output Source Current Surge	I_{out} (ECL)	200	mAdc
Storage Temperature	T_{stg}	-65 to 150	°C
Operating Temperature	T_{amb}	0.0 to +75	°C

MC10H680 MC100H680

ECL DC CHARACTERISTICS: $V_{CCT} = +5.0\text{ V} \pm 10\%$, $V_{EE} = -5.2 \pm 5\%$ (10H Version); $V_{EE} = -4.2\text{ V}$ to -5.5 V (100H Version)

Test Symbol	Parameter	$T_A = 0^\circ\text{C}$		$T_A = 25^\circ\text{C}$		$T_A = 75^\circ\text{C}$		Unit	Condition
		Min	Max	Min	Max	Min	Max		
I_{EE}	Supply Current/ECL		-110		-110		-110	mA	
I_{INH}	Input HIGH Current		225		145		145	μA	
I_{INL}	Input LOW Current	0.5		0.5		0.3		μA	
V_{OH} V_{OL}	Output HIGH Voltage Output LOW Voltage	-1100 -2.1	-840 -2.03	-1100 -2.1	-810 -2.03	-1100 -2.1	-735 -2.03	mV V	25 Ω to -2.1 V

CONTROL INPUTS ONLY

10H ECL DC CHARACTERISTICS: $V_{CCT} = +5.0 \pm 10\%$, $V_{EE} = -5.2 \pm 5\%$

Test Symbol	Parameter	$T_A = 0^\circ\text{C}$		$T_A = 25^\circ\text{C}$		$T_A = 75^\circ\text{C}$		Unit	Condition
		Min	Max	Min	Max	Min	Max		
V_{IH} V_{IL}	Input HIGH Voltage Input LOW Voltage	-1170 -1950	-840 -1480	-1130 -1950	-810 -1480	-1070 -1950	-735 -1450	mV	

CONTROL INPUTS ONLY

100H ECL DC CHARACTERISTICS: $V_{CCT} = +5.0 \pm 10\%$, $V_{EE} = -4.2\text{ V}$ to -5.5 V

Test Symbol	Parameter	$T_A = 0^\circ\text{C}$		$T_A = 25^\circ\text{C}$		$T_A = 75^\circ\text{C}$		Unit	Condition
		Min	Max	Min	Max	Min	Max		
V_{IH} V_{IL}	Input HIGH Voltage Input LOW Voltage	-1165 -1810	-880 -1475	-1165 -1810	-880 -1475	-1165 -1810	-880 -1475	mV	

TTL DC CHARACTERISTICS: $V_{CCT} = +5.0\text{ V} \pm 10\%$, $V_{EE} = -5.2 \pm 5\%$ (10H Version); $V_{EE} = -4.2\text{ V}$ to -5.5 V (100H Version)

Test Symbol	Parameter	$T_A = 0^\circ\text{C}$		$T_A = 25^\circ\text{C}$		$T_A = 75^\circ\text{C}$		Unit	Condition
		Min	Max	Min	Max	Min	Max		
V_{IH} V_{IL}	Standard Input Standard Input	2.0	0.8	2.0	0.8	2.0	0.8	Vdc	
V_{IK}	Input Clamp		-1.2		-1.2		-1.2	Vdc	$I_{IN} = -18\text{ mA}$
V_{OH} V_{OL}	Output HIGH Voltage Output HIGH Voltage	2.5 2.0		2.5 2.0		2.5 2.0		V	$I_{OH} = -3.0\text{ mA}$ $I_{OH} = -15\text{ mA}$
V_{OL}	Output LOW Voltage		0.55		0.55		0.55	V	$I_{OL} = 48\text{ mA}$
I_{IH}^* I_{IL}^*	TTL (Input HIGH) TTL (Input HIGH)		20 100		20 100		20 100	μA	$V_{in} = 2.7\text{ V}$ $V_{in} = 7.0\text{ V}$
I_{IL}^*	TTL (Input LOW)		-0.6		-0.6		-0.6	mA	$V_{in} = 0.5\text{ V}$
I_{CCL}	Supply Current		75		75		75	mA	
I_{CCH}	Supply Current		70		70		70	mA	
I_{CCZ}	Supply Current		70		70		70	mA	
I_{OS}	Output Short Circuit Current	-100	-225	-100	-225	-100	-225	mA	$V_{OUT} = 0\text{ V}$

* NOTE: TTL Control Inputs only

TTL I/O DC CHARACTERISTICS ONLY

Test Symbol	Parameter	$T_A = 0^\circ\text{C}$		$T_A = 25^\circ\text{C}$		$T_A = 75^\circ\text{C}$		Unit	Condition
		Min	Max	Min	Max	Min	Max		
I_{IH}/I_{OZH} I_{IL}/I_{OZL}	Output Disable Current		70 200		70 200		70 200	μA	$V_{OUT} = 2.7\text{ V}$ $V_{OUT} = 0.5\text{ V}$

ECL TO TTL DIRECTION / AC TEST

Test Symbol	Parameter	Waveforms	T _A = 0°C		T _A = 25°C		T _A = 75°C		Unit	Condition
			Min	Max	Min	Max	Min	Max		
t _{PLH} t _{PHL}	Propagation Delay to Output	2, 4	2.7	4.8	2.7	4.8	2.7	4.8	ns	C _L = 50 pF
t _{PZH} t _{PZL}	ECEB to Output Enable Time	2, 5, 6	3.5 3.5	6.5 6.0	3.5 3.5	6.5 6.0	3.7 3.7	6.7 6.4	ns	C _L = 50 pF
t _{PHZ} t _{PLZ}	ECEB to Output Disable Time	2, 5, 6	3.5 3.5	8.6 6.5	3.5 3.5	8.6 6.5	3.7 3.7	8.8 7.3	ns	C _L = 50 pF
t _{PZH} t _{PZL}	TCEB to Output Enable Time	2, 5, 6	5.7 5.4	7.7 6.9	5.7 5.4	7.7 6.9	5.9 5.9	7.9 7.4	ns	C _L = 50 pF
t _{PHZ} t _{PLZ}	TCEB to Output Disable Time	2, 5, 6	4.0 4.0	8.5 5.8	4.1 4.2	8.4 6.0	4.2 4.7	8.3 6.5	ns	C _L = 50 pF
t _r /t _f	1.0 to 2.0 Vdc	3	0.4	1.5	0.4	1.5	0.4	1.5	ns	C _L = 50 pF

TTL TO ECL DIRECTION / AC TEST

Test Symbol	Parameter	Waveforms	T _A = 0°C		T _A = 25°C		T _A = 75°C		Unit	Condition
			Min	Max	Min	Max	Min	Max		
t _{PLH} t _{PHL}	Propagation Delay to Output	1, 4	1.8	4.6	1.8	4.6	2.0	4.9	ns	25 Ω to -2.0 V
t _{PLH} t _{PHL}	ECEB to Output	1, 4	2.9	5.1	3.0	5.2	3.4	5.7	ns	25 Ω to -2.0 V
t _{PLH} t _{PHL}	TCEB to Output	1, 4	3.4	6.3	3.5	6.6	3.8	7.4	ns	25 Ω to -2.0 V
t _r /t _f	Output Rise/Fall Time 20%–80%	1, 3	1.0	3.4	1.0	3.4	1.0	3.4	ns	25 Ω to -2.0 V

MC10H680 MC100H680

BLOCK DIAGRAM

CONTROL INPUTS

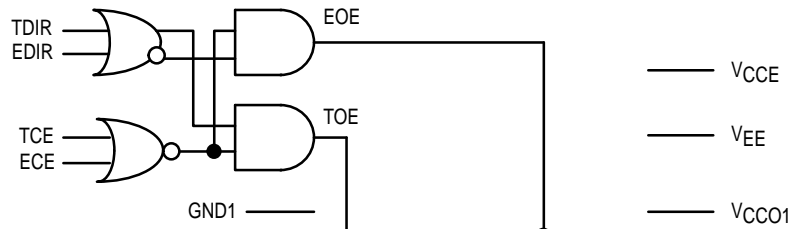

TTL I/O

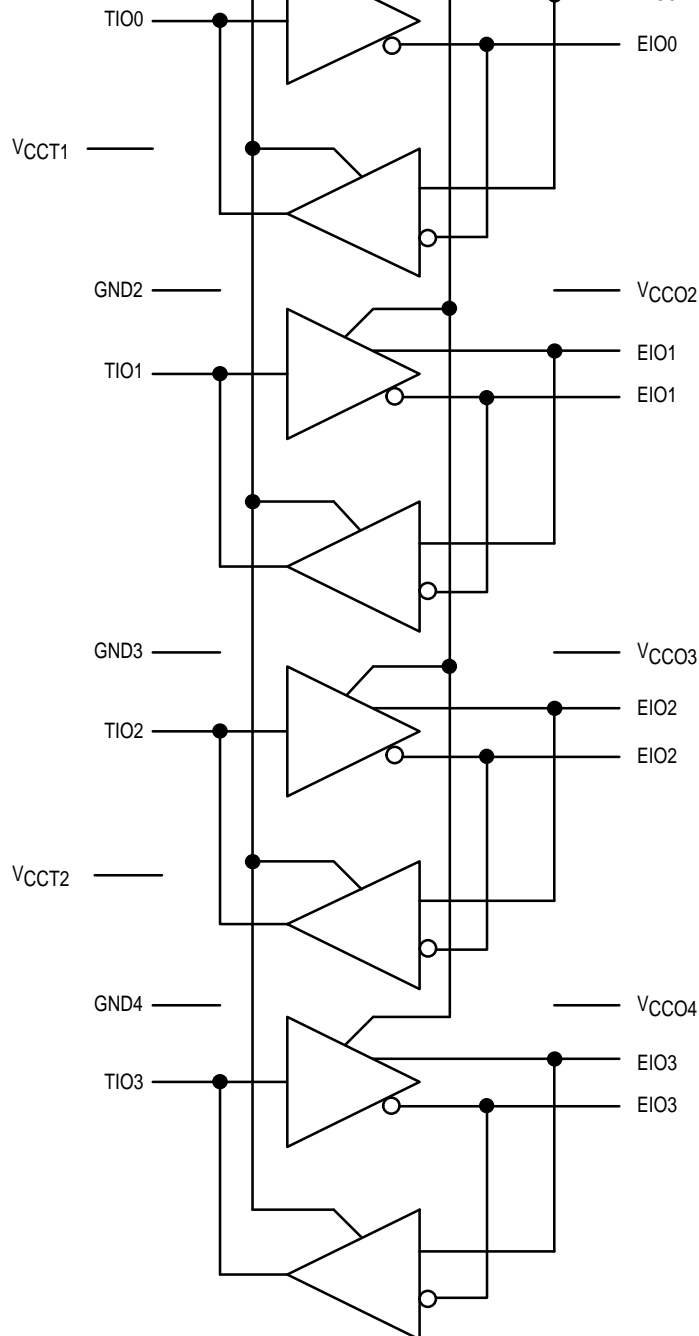

ECL I/O

SWITCHING CIRCUIT AND WAVEFORMS

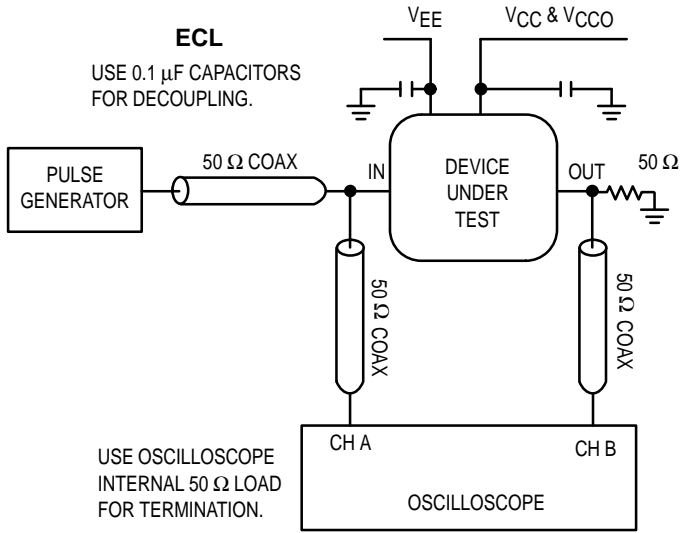

Figure 1. Switching Circuit ECL

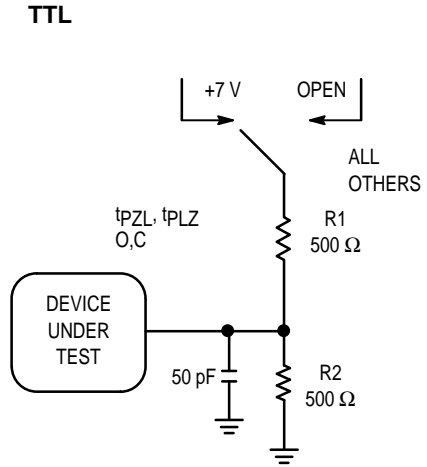

Figure 2.

ECL/TTL

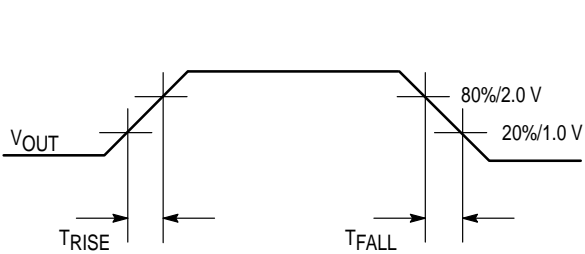

Figure 3. WAVEFORMS: Rise and Fall Times

ECL/TTL

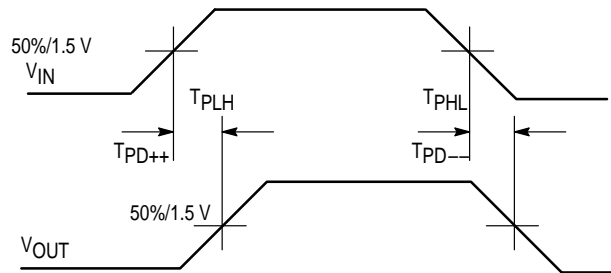

Figure 4. Propagation Delay — Single Ended

TTL

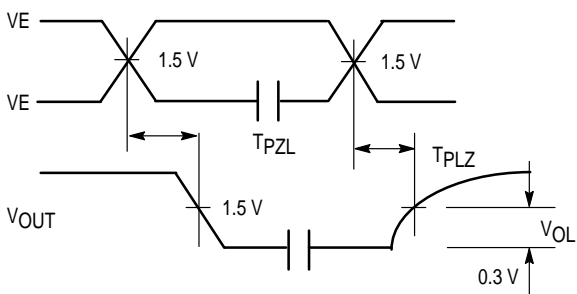

Figure 5. 3-State Output Low Enable and Disable Times

TTL

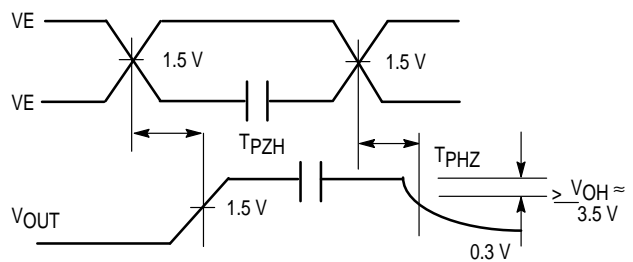
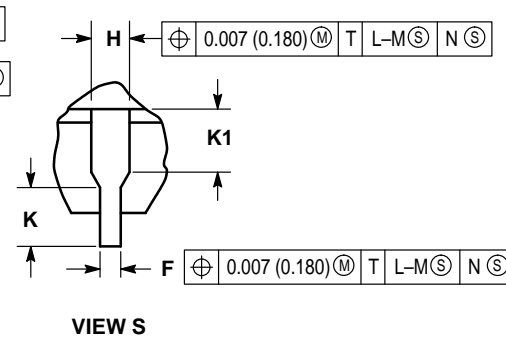
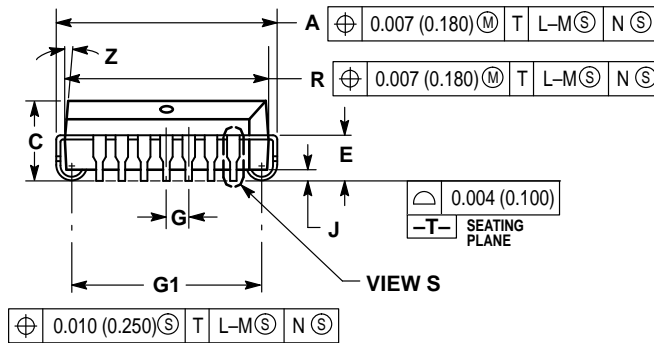
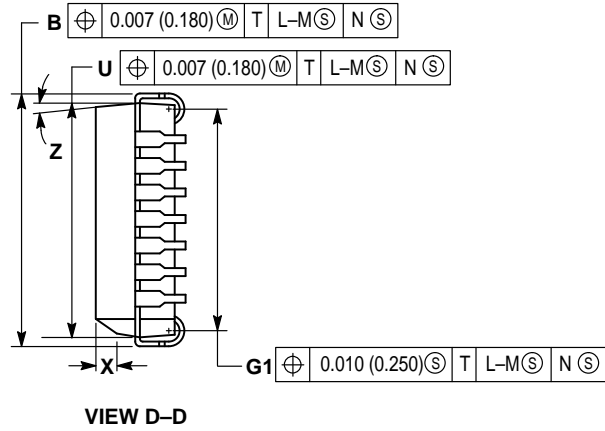
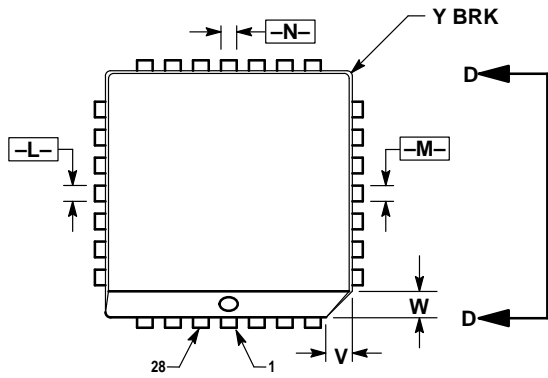

Figure 6. 3-State Output High Enable and Disable Times

OUTLINE DIMENSIONS

FN SUFFIX
 PLASTIC PLCC PACKAGE
 CASE 776-02
 ISSUE D



NOTES:

- DATUMS -L-, -M-, AND -N- DETERMINED WHERE TOP OF LEAD SHOULDER EXITS PLASTIC BODY AT MOLD PARTING LINE.
- DIMENSION G1, TRUE POSITION TO BE MEASURED AT DATUM -T-, SEATING PLANE.
- DIMENSIONS R AND U DO NOT INCLUDE MOLD FLASH. ALLOWABLE MOLD FLASH IS 0.010 (0.250) PER SIDE.
- DIMENSIONING AND TOLERANCING PER ANSI Y14.5M, 1982.
- CONTROLLING DIMENSION: INCH.
- THE PACKAGE TOP MAY BE SMALLER THAN THE PACKAGE BOTTOM BY UP TO 0.012 (0.300). DIMENSIONS R AND U ARE DETERMINED AT THE OUTERMOST EXTREMES OF THE PLASTIC BODY EXCLUSIVE OF MOLD FLASH, TIE BAR BURRS, GATE BURRS AND INTERLEAD FLASH, BUT INCLUDING ANY MISMATCH BETWEEN THE TOP AND BOTTOM OF THE PLASTIC BODY.
- DIMENSION H DOES NOT INCLUDE DAMBAR PROTRUSION OR INTRUSION. THE DAMBAR PROTRUSION(S) SHALL NOT CAUSE THE H DIMENSION TO BE GREATER THAN 0.037 (0.940). THE DAMBAR INTRUSION(S) SHALL NOT CAUSE THE H DIMENSION TO BE SMALLER THAN 0.025 (0.635).

DIM	INCHES		MILLIMETERS	
	MIN	MAX	MIN	MAX
A	0.485	0.495	12.32	12.57
B	0.485	0.495	12.32	12.57
C	0.165	0.180	4.20	4.57
E	0.090	0.110	2.29	2.79
F	0.013	0.019	0.33	0.48
G	0.050 BSC		1.27 BSC	
H	0.026	0.032	0.66	0.81
J	0.020	—	0.51	—
K	0.025	—	0.64	—
R	0.450	0.456	11.43	11.58
U	0.450	0.456	11.43	11.58
V	0.042	0.048	1.07	1.21
W	0.042	0.048	1.07	1.21
X	0.042	0.056	1.07	1.42
Y	—	0.020	—	0.50
Z	2°	10°	2°	10°
G1	0.410	0.430	10.42	10.92
K1	0.040	—	1.02	—

Motorola reserves the right to make changes without further notice to any products herein. Motorola makes no warranty, representation or guarantee regarding the suitability of its products for any particular purpose, nor does Motorola assume any liability arising out of the application or use of any product or circuit, and specifically disclaims any and all liability, including without limitation consequential or incidental damages. "Typical" parameters which may be provided in Motorola data sheets and/or specifications can and do vary in different applications and actual performance may vary over time. All operating parameters, including "Typicals" must be validated for each customer application by customer's technical experts. Motorola does not convey any license under its patent rights nor the rights of others. Motorola products are not designed, intended, or authorized for use as components in systems intended for surgical implant into the body, or other applications intended to support or sustain life, or for any other application in which the failure of the Motorola product could create a situation where personal injury or death may occur. Should Buyer purchase or use Motorola products for any such unintended or unauthorized application, Buyer shall indemnify and hold Motorola and its officers, employees, subsidiaries, affiliates, and distributors harmless against all claims, costs, damages, and expenses, and reasonable attorney fees arising out of, directly or indirectly, any claim of personal injury or death associated with such unintended or unauthorized use, even if such claim alleges that Motorola was negligent regarding the design or manufacture of the part. Motorola and  are registered trademarks of Motorola, Inc. Motorola, Inc. is an Equal Opportunity/Affirmative Action Employer.

How to reach us:

USA/EUROPE/Locations Not Listed: Motorola Literature Distribution;
P.O. Box 20912; Phoenix, Arizona 85036. 1-800-441-2447 or 602-303-5454

MFAX: RMFAX0@email.sps.mot.com – TOUCHTONE 602-244-6609
INTERNET: <http://Design-NET.com>

JAPAN: Nippon Motorola Ltd.; Tatsumi-SPD-JLDC, 6F Seibu-Butsuryu-Center,
3-14-2 Tatsumi Koto-Ku, Tokyo 135, Japan. 03-81-3521-8315

ASIA/PACIFIC: Motorola Semiconductors H.K. Ltd.; 8B Tai Ping Industrial Park,
51 Ting Kok Road, Tai Po, N.T., Hong Kong. 852-26629298